

LOC	DIST	REVISIONS			
P	LTR	DESCRIPTION	DATE	DWN	APVD
DW	-				
	A	REVISED (ECR-09-012037)	27MAY09	JL	WK

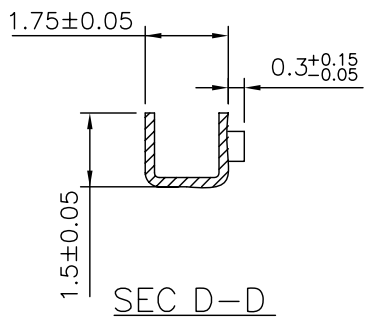
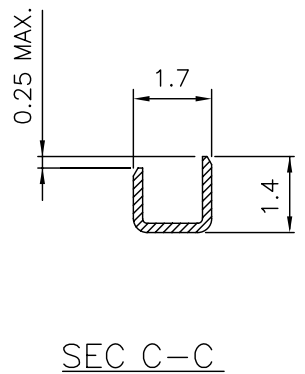
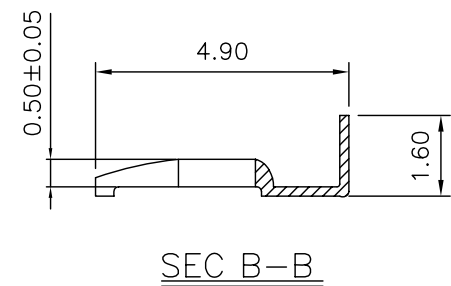
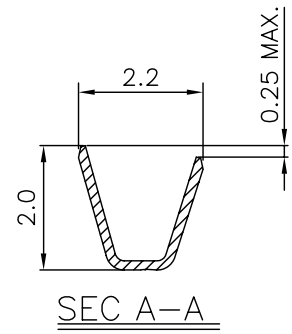
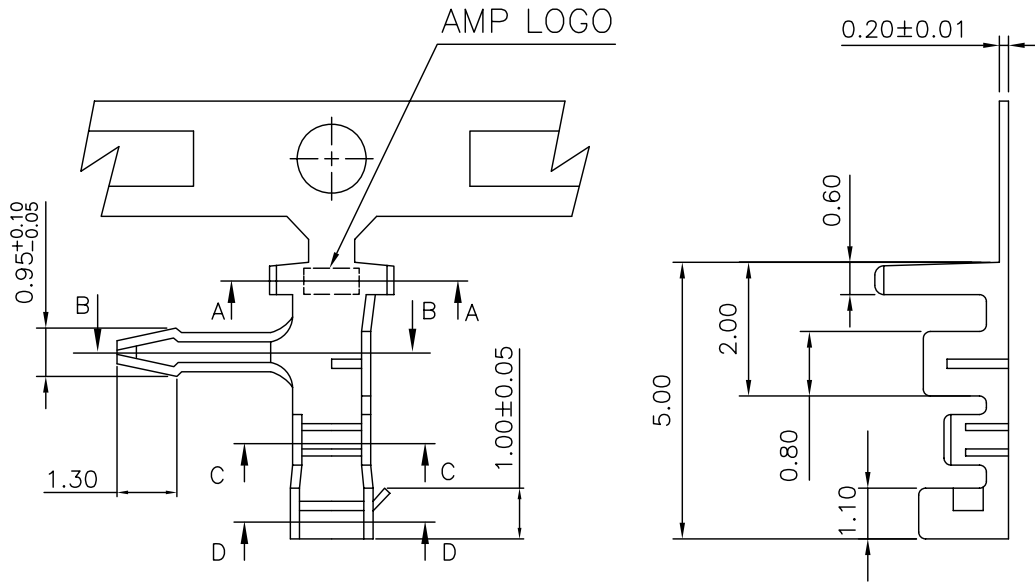

- NOTE:
- MATERIAL :  
TERMINAL: BRASS.
  - FINISHED :  
TERMINAL: 1.27um [50u"] MIN. TIN ON SOLDER TAILS,  
0.381um [15u"] MIN. NICKEL UNDERPLATED  
ALL OVER.
  - ACCEPTS HOUSING: X-1470199-X.

1470200-1  
PART NUMBER

THIS DRAWING IS A CONTROLLED DOCUMENT.		DWN J. LAI 27MAY2009	Tyco Electronics Corporation Taipei, Taiwan	
DIMENSIONS: MM		CHK S. CHIEN 27MAY2009	NAME	
TOLERANCES UNLESS OTHERWISE SPECIFIED:		APVD W. KODAMA 27MAY2009	PRODUCT SPEC	
0 PLC ± - 1 PLC ± 0.20 2 PLC ± 0.10 3 PLC ± 0.05 4 PLC ANGLES ± -		APPLICATION SPEC		
MATERIAL SEE NOTE		FINISH SEE NOTE	108-57158 501-57248 WEIGHT - GRAMS A3 00779 C=1470200	
		ANGLE, CONTACT 2.0 MM PITCH, CRIMP, RIGHT SIZE CAGE CODE DRAWING NO RESTRICTED TO A3 00779 C=1470200 -		CUSTOMER DRAWING SCALE - SHEET 1 OF 2 REV A

4

3

2

1

THIS DRAWING IS UNPUBLISHED.

RELEASED FOR PUBLICATION AUG 2006.

© COPYRIGHT 2009 BY TYCO ELECTRONICS CORPORATION. ALL RIGHTS RESERVED.

LOC  
DW

DIST

REVISIONS

P	LTR	DESCRIPTION	DATE	DWN	APVD
		SEE SHEET 1.			

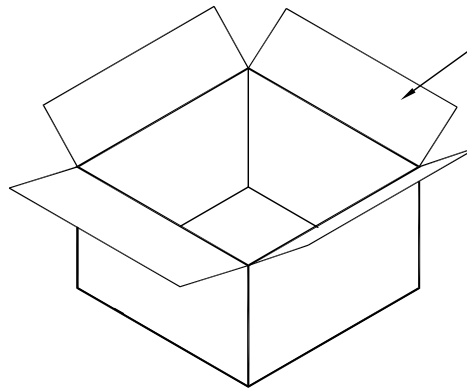

CARTON  
590mm(L)X590mm(W)X115mm(H)  
40,000 TERMINALS / CARTON

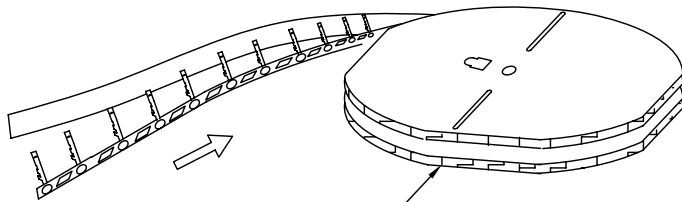

REEL  
DIAMETER:  $\phi$ 580mm.  
10,000 TERMINALS / REEL

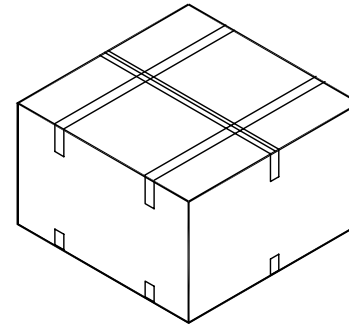

THIS DRAWING IS A CONTROLLED DOCUMENT.		DWN		Tyco Electronics Corporation Taipei, Taiwan	
DIMENSIONS: MM		TOLERANCES UNLESS OTHERWISE SPECIFIED:		NAME	
		0 PLC ± -		PRODUCT SPEC	
		1 PLC ± -		APPLICATION SPEC	
		2 PLC ± -		SIZE	
		3 PLC ± -		CAGE CODE	
		4 PLC ± -		DRAWING NO	
		ANGLES ± -		RESTRICTED TO	
MATERIAL		FINISH		A3 00779 C=1470200	
CUSTOMER DRAWING				SCALE	
				SHEET 2 OF 2	
				REV A	