



RECOM

We've got the **Power.**

HIGH POWER WHITE LIGHT
**CONSTANT CURRENT
LED-DRIVERS**



DROP IN REPLACEMENT FOR
3-PIN REGULATORS (78 SERIES)
SWITCHING REGULATORS
EFFICIENCIES UP TO 97%

100% POWER. NO DERATING.
HIGH EFFICIENCY HIGH TEMP.
DC-DC POWER MODULES

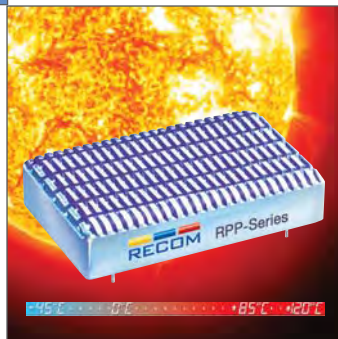

NEW!



MICROSIZE PCB MOUNT
SAFETY APPROVED
AC-DC MODULES

Application Notes 2009

POWERLINE PLUS

100% DC-DC Power. No derating.



-45°C

0°C

+85°C

+120°C

- From -45°C up to 100°C Full Load Operating Temperature
- Built-in EN55022/FCC Class B EMC Filter
- Up to 3kVDC Isolation
- Compact Size, Standard Pinouts
- Efficiency above 90%
- Single & Dual Outputs
- 2:1 and 4:1 Input Voltage Ranges
- 20W, 30W, 40W or 50W DC-DC Power Packages



The POWERLINE PLUS uses ICE Technology. A combination of techniques to minimise internal heat dissipation and maximise the heat transfer to ambient to create a new converter series which offers high end performance at a price which is significantly lower than conventional specialist converters. RECOM - Green high-efficiency power solutions. **SAVE ENERGY. NOW.**



CHOOSING THE RIGHT CONVERTER: A GUIDE for DC/DC Converters

- Step 1:** Do you need Isolation? (An isolated converter has outputs that are floating and not connected to the inputs i.e. they are galvanically isolated)
- No isolation needed: Check our Ininline parts first (R-78 series, R-5xxx, R-6xxx and R-7xxx series)
- Isolation needed: decide whether you need 1kVDC/1 sec (standard) or 1.6VDC/1 sec, 2kVDC/1 sec, 3kVDC/1 sec, 4kVDC/1 sec, 5.2kVDC/1 sec or 6kVDC/1 sec.
- Step 2:** Decide on the output voltage and number of outputs: single, dual bipolar (+/-), dual isolated or triple.
- It is also important to decide whether the output voltage needs to be regulated or unregulated.
- Unregulated converters are offered standard without short circuit protection or optionally with short circuit protection (option /P)
- All Series are available with single outputs.
- Please note that a dual output converter can be used as a single output by leaving the common pin unconnected i.e. +/-5V = 10V, +/-12V = 24V, +/-15V = 30V, etc.
- Step 3:** Decide on the output current. The output voltage times the output current gives the output power of the converter in Watts.
- DC/DC converters are designed to run at full load, so only round up the power if a suitable converter is not available.
- e.g. 5V @ 150mA = 0.75W = 1W converter.
- e.g. +/-15V @ +/-1A = 30W = 30W converter.
- Step 4:** Decide on the input voltage. Standard input voltage ranges are:
- 3.3, 5, 9, 12, 15, and 24VDC with +/-10% tolerance
- 4.5 ~ 9V, 9 ~ 18V, 18 ~ 36V and 36 ~ 72VDC with 2:1 input voltage range
- 9 ~ 36V and 18 ~ 72VDC with 4:1 input voltage range.
- Step 5:** Decide on the case style and pin-out. Many Recom series are available in either through hole or surface mount styles and with several pin-out options, including Remote On/Off Control.
- Step 6:** Use either the **Selection** guide or **Contents** guide at the start of each section to find the most appropriate converter.

REMEMBER: THERE IS AN INTERACTIVE SELECTION GUIDE ON OUR WEBSITES

Go to **WWW.RECOM-INTERNATIONAL.COM** then click on **PRODUCT SEARCH**

Go to **WWW.RECOM-POWER.COM** then click on **PRODUCT SEARCH: SPEC BY STEP**

SPECIFICATION CHECKLIST

Use this checklist to help you define your specification. If you can't find a converter that fulfils your needs then call us, fax us, e-mail us or use our Web Sample Enquiry link and we will find the best match for you.

1. Non-Isolated Isolation Required _____kVDC or _____kVAC
2. Single Output Dual Bipolar Output Other:
Output Voltages (V) _____ / _____ / _____
Output Currents (A) _____ / _____ / _____
3. Total Output Power (V x A) _____
4. Regulated Unregulated
5. Short Circuit Protection: No Yes
6. Remote Control Pin: No Yes
7. Output Voltage Trim: No Yes
8. Input Voltage: minimum _____ maximum _____
9. Mounting Style: Through Hole SMD
Single-In-Line Pins SIP4 SIP6 SIP7 SIP8 SIP12
Dual-In-Line Pins DIP8 DIP14 DIP16 DIP24 - Pinout? A_B_C_
Standard Brick 1" x 1" 1" x 2" 1.6" x 2" 2" x 2"
Case Style: Metal Case Plastic Case Open Frame
10. Certifications Required: None EN 60950-1 EN 60601-1 UL 60950-1
11. Operating Temperature Range: minimum _____ maximum _____
12. Heatsink required : No Yes
13. Other Requirements: _____

REMEMBER: THERE IS AN INTERACTIVE SELECTION GUIDE ON OUR WEBSITES

Go to WWW.RECOM-INTERNATIONAL.COM then click on **PRODUCT SEARCH**

Go to WWW.RECOM-POWER.COM then click on **PRODUCT SEARCH: SPEC BY STEP**

Contents

ECONOLINE (General Apps.)

- **Terminology**

Input Range

Load Regulation

Line Voltage Regulation

Output Voltage Accuracy

Input and Output Ripple and Noise

Input to Output Isolation

Insulation Resistance

Efficiency at Full Load

Temperature Drift

Switching Frequency

No Load Power Consumption

Isolation Capacitance

Mean Time Between Failure (MTBF)

Noise

Operating Temperature Range

Calculation of Heatsinks

- **Isolation**

Isolation Voltage vs. Rated Working Voltage

- **Isolation mode in IGBT Driver Circuits**

- Connecting DC-DC Converters in Series

- Connecting DC-DC Converters in Parallel

- Chaining DC-DC Converters

- **Filtering**

Output Filtering Calculation

- **Limiting Inrush Current**

- **Maximum Output Capacitance**

- **Settling Time**

- **Isolation Capacitance and Leakage Current**

- **Application Examples**

Overload Protection

Input Voltage Drop-Out (brown-outs)

No Load Over Voltage Lock-Out

Long Distance Supply Lines

LCD Display Bias

Pre- and Post Regulation

EIA-232 Interface

3V/5V Logic Mixed Supply Rails

Isolated Data Acquisition System

- **EMC Considerations**

Power Supply Considerations

Interpretation of DC-DC Converter EMC Data

Conducted and Radiated Emissions

Line Impedance Stabilisation Network (LISN)

Shielding

Line Spectra of DC-DC Converters

- Temperature Performance of DC-DC Converters

- Transfer Moulded (SMD) DC-DC Converters

Production Guideline Application Note

Component Materials

Component Placement

Component Alignment

Solder Pad Design

Solder Reflow Profile

Recommended Solder Reflow Profile

Adhesive Requirements

Adhesive Placement

Cleaning

Vapour Phase Reflow Soldering

- **Tin Whisker Mitigation**

INNOLINE

- EMC Filter Suggestion

- **Soft Start Circuit**

- Positive - to - Negative Converters

POWERLINE DC-DC

- **EMC Filter Suggestion**

- **General Test Set-Up**

- **Input Voltage Range**

- **PI Filter**

- **Output Voltage Accuracy**

- **Voltage Balance**

- **Line Regulations**

- **Load Regulation**

- **Efficiency**

- **Switching Frequency**

- **Output Ripple and Noise**

- **Output Ripple and Noise (continued)**

- **Transient Recovery Time**

- **Current Limiting**

- **Fold Back Current Limiting**

- **Isolation**

- **Break-Down Voltage**

- **Temperature Coefficient**

- **Ambient Temperature**

- **Operating Temperature Range**

- **Storage Temperature Range**

- **Output Voltage Trimming**

- **Heat Sinks**

POWERLINE AC/DC

- **Input Fuse**

- **Earthing**

- **External Filter**

- **Paralleling AC/DC Converters**

- **Chaining Converters**

- **DC Inputs**

BLOCK DIAGRAMS

Transport Tubes & Reels

Terminology

The data sheet specification for DC-DC converters contains a large quantity of information. This terminology is aimed at ensuring that the user can interpret the data provided correctly and obtain the necessary information for their circuit application.

Input Range

The range of input voltage that the device can tolerate and maintain functional performance over the Operating Temperature Range at full load.

Load Regulation

The change in output voltage over the specified change in output load. Usually specified as a percentage of the nominal output voltage, for example, if a 1V change in output voltage is measured on a 12V output device, load voltage regulation is 8.3%. For unregulated devices the load voltage regulation is specified over the load range from 10% to 100% of full load.

Line Voltage Regulation

The change in output voltage for a given change in input voltage, expressed as percentages. For example, assume a 12V in-put, 5V output device exhibited a 0.5V change at the output for a 1.2V change at the input, line regulation would be 1%/1%.

Output Voltage Accuracy

The proximity of the output voltage to the specified nominal value. This is given as a tolerance envelope for unregulated devices with the nominal input voltage applied. For example, a 5V specified output device at 100% load may exhibit a measured output voltage of 4.75V, i.e. a voltage accuracy of -5%.

Input and Output Ripple and Noise

The amount of voltage drop at the input, or output between switching cycles. The value of voltage ripple is a measure of the storage ability of the filter capacitors. The values given in the datasheets include the higher frequency Noise interference superimposed on the ripple due to switching spikes. The measurement is limited to 20MHz Bandwidth.

Input to Output Isolation

The dielectric breakdown strength test between input and output circuits. This is the isolation voltage the device is capable of withstanding for a specified time, usually 1 second (for more details see chapter "Isolation Voltage vs. Rated Working Voltage").

Insulation Resistance

The resistance between input and output circuits. This is usually measured at 500V DC isolation voltage.

Efficiency at Full Load

The ratio of power delivered from the device to power supplied to the device when the part is operating under 100% load conditions at 25°C.

Temperature Drift

The change in voltage, expressed as a percentage of the nominal, per degree change in ambient temperature. This parameter is related to several other temperature dependent parameters, mainly internal component drift.

Switching Frequency

The nominal frequency of operation of the switching circuit inside the DC-DC converter. The ripple observed on the input and output pins is usually twice the switching frequency, due to full wave rectification and the push-pull configuration of the driver circuit.

No Load Power Consumption

This is a measure of the switching circuits power consumption; it is determined with zero output load and is a limiting factor for the total efficiency of the device.

Isolation Capacitance

The input to output coupling capacitance. This is not actually a capacitor, but the parasitic capacitive coupling between the transformer primary and secondary windings. Isolation capacitance is typically measured at 1 MHz to reduce the possibility of the on-board filter capacitors affecting the results.

Mean Time Between Failure (MTBF)

RECOM uses MIL-HDBK-217F standard for calculation of MTBF values for +25°C as well as for max. operating temperature and 100% load. When comparing MTBF values with other vendor's products, please take into account the different conditions and standards i.e. MIL-HDBK-217E is not as severe and therefore values shown will be higher than those shown by RECOM. (1000 x 10³ hours = 1000000 hours = 114 years!) These figures are calculated expected device lifetime figures using the hybrid circuit model of MIL-HDBK-217F. POWERLINE converters also can use BELLCORE TR-NWT-000332 for calculation of MTBF. The hybrid model has various accelerating factors for operating environment (π_E), maturity (π_L), screening (π_Q), hybrid function (π_F) and a summation of each individual component characteristic (λ_C).

The equation for the hybrid model is then given

by:

$$\lambda = \Sigma (N_C \lambda_C) (1 + 0.2\pi_E) \pi_L \pi_F \pi_Q$$

(failures in 10⁶ hours)

The MTBF figure is the reciprocal of this value. In the data sheets, all figures for MTBF are given for the ground benign (GB) environment ($\pi_E = 0.5$); this is considered the most appropriate for the majority of applications in which these devices are likely to be used. However, this is not the only operating environment possible, hence those users wishing to incorporate these devices into a more severe environment can calculate the predicted MTBF from the following data.

The MIL-HDBK-217F has military environments specified, hence some interpretation of these is required to apply them to standard commercial environments. Table 1 gives approximate cross references from MIL-HDBK-217F descriptions to close commercial equivalents. Please note that these are not implied by MIL-HDBK-217F, but are our interpretation. Also we have reduced the number of environments from 14 to 6, which are most appropriate to commercial applications. For a more detailed understanding of the environments quoted and the hybrid model, it is recommended that a full copy of MIL-HDBK-217F is obtained.

It is interesting to note that space flight and ground benign have the same environment factors. It could be suggested that the act of achieving space flight should be the determining environmental factor (i.e. missile launch).

The hybrid model equation can therefore be rewritten for any given hybrid, at a fixed temperature, so that the environmental factor is the only variable:

$$\lambda = k (1 + 0.2 \pi_E)$$

The MTBF values for other environment factors can therefore be calculated from the ground benign figure quoted at each temperature point in the data book. Hence predicted MTBF figures for other environments can be calculated very quickly. All the values will in general be lower and, since the majority of the mobile environments have the same factor, a quick divisor can be calculated for each condition. Therefore the only calculation necessary is to divide the quoted MTBF fig. by the divisor given in table 2.

Environment	π_E Symbol	MIL-HDBK-271F Description	Commercial Interpretation or Examples
Ground Benign	GB	Non-mobile, temperature and humidity controlled environments readily accessible to maintenance	Laboratory equipment, test instruments, desktop PC's, static telecomms
Ground Mobile	GM	Equipment installed in wheeled or tracked vehicles and equipment manually transported	In-vehicle instrumentation, mobile radio and telecomms, portable PC's
Naval Sheltered	NS	Sheltered or below deck equipment on surface ships or submarines	Navigation, radio equipment and instrumentation below deck
Aircraft Inhabited Cargo	AIC	Typical conditions in cargo compartments which can be occupied by aircrew	Pressurised cabin compartments and cock-pits, in flight entertainment and non-safety critical applications
Space Flight	SF	Earth orbital. Vehicle in neither powered flight nor in atmospheric re-entry	Orbital communications satellite, equipment only operated once in-situ
Missile Launch	ML	Severe conditions relating to missile launch	Severe vibrational shock and very high accelerating forces, satellite launch conditions

Table 1: Interpretation of Environmental Factors

Environment	π_E Symbol	π_E Value	Divisor
Ground Benign	GB	0.5	1.00
Ground Mobile	GM	4.0	1.64
Naval Sheltered	GNS	4.0	1.64
Aircraft Inhabited Cargo	AIC	4.0	1.64
Space Flight	SF	0.5	1.00
Missile Launch	ML	12.0	3.09

Table 2: Environmental Factors

Noise

Input conducted noise is given in the line conducted spectra for each DC-DC converter (see EMC issues for further details). Noise is affected significantly by PCB layout, measurement system configuration, terminating impedance etc., and is difficult to quote reliably and with any accuracy other than via a spectrum analysis type plot. There will be some switching noise present on top of the ripple, however, most of this is easily reduced by use of small capacitors or filter inductors, as shown in the application notes.

Operating temperature range:

Operating temperature range of the converter is limited due to specifications of the components used for the internal circuit of the converter.

The diagram for temperature derating shows the safe operating area (SOA) within which the device is allowed to operate. At very low temperatures, the specifications are only guaranteed for full load.

Up to a certain temperature 100% power can be drawn from the device, above this temperature the output power has to be less to ensure function and guarantee specifications over the whole lifetime of the converter.

These temperature values are valid for natural convection only. If the converter is used in a closed case or in a potted PCB board, higher temperatures will be present in the area around thermal converter because the convection may be blocked.

If the same power is also needed at higher temperatures either the next higher wattage series should be chosen or if the converter has a metal case, a heatsink may be considered.

Please refer to the Powerline Application Notes Section for more information on thermal impedance and heatsinking.

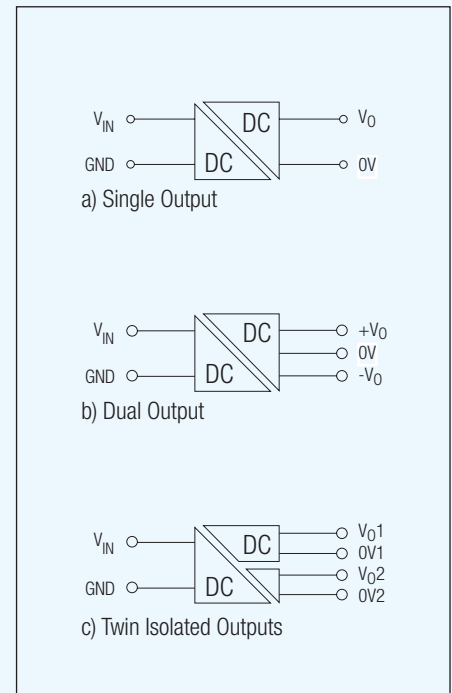

Figure 1: Standard Isolated Configurations

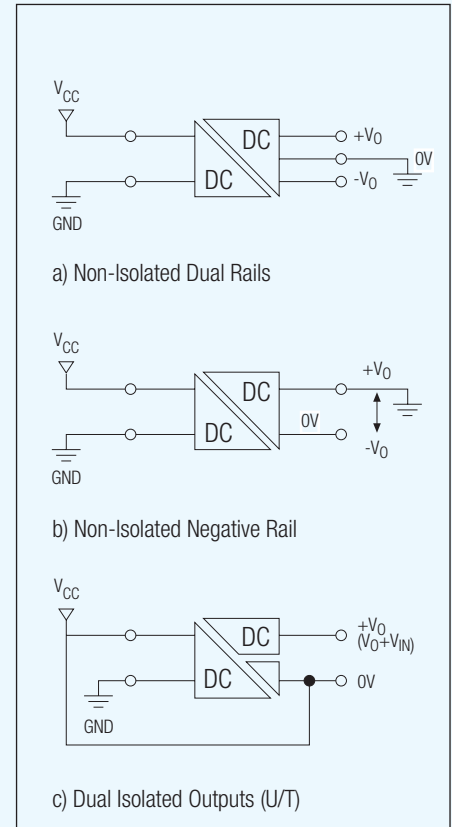

Figure 2: Alternative Supply Configurations

Isolation

One of the main features of the majority of Recom DC-DC converters is their high galvanic isolation capability. This allows several variations on circuit topography by using a single DC-DC converter.

The basic input to output isolation can be used to provide either a simple isolated output power source, or to generate different voltage rails, and/or dual polarity rails (see figure 1).

These configurations are most often found in instrumentation, data processing and other noise sensitive circuits, where it is necessary to isolate the load and noise presented to the local power supply rails from that of the entire system. Usually local supply noise appears as common mode noise at the converter and does not pollute the main system power supply rails. The isolated positive output can be connected to the input ground rail to generate a negative supply rail if required. Since the output is isolated from the input, the choice of reference voltage for the output side can be arbitrary, for example an additional single rail can be generated above the main supply rail, or offset by some other DC value (see figure 2).

Regulated converters need more consideration than the unregulated types for mixing the reference level. Essentially the single supply rail has a regulator in its +Vout rail only, hence referencing the isolated ground will only work if all the current return is through the DC-DC and not via other external components (e.g. diode

bias, resistor feed). Having an alternative return path can upset the regulation and the performance of the system may not equal that of the converter.

Isolation Voltage vs. Rated Working Voltage

The isolation voltage given in the datasheet is valid for 1 second flash tested only.

If a isolation barrier is required for longer or infinite time the Rated Working Voltage has to be used.

Conversion of Isolation Voltage to Rated Working Voltage can be done by using this table or graph.

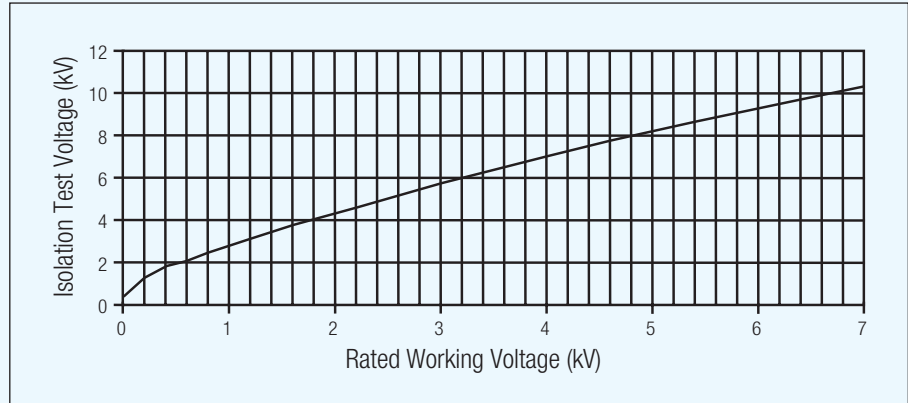

Figure 5: IEC950 Test Voltage for Electrical Strength Tests

Isolation Test Voltage (V)	Rated Working Voltage (V)
1000	130
1500	230
3000	1100
6000	3050

Table 2: Typical Breakdown Voltage Ratings According to IEC950

The graph and table above show the requirements from IEC950. According to our experience and in-house tests, we can offer the following conversion tables:

Isolation Test Voltage (1 second)	Isolation Test Voltage (1 minute)	Isolation Test Voltage (1 minute)
500 VDC	400 VDC	250 VAC
1000 VDC	800 VDC	500 VAC
1500 VDC	1200 VDC	750 VAC
2000 VDC	1600 VDC	1000 VAC
2500 VDC	2000 VDC	1250 VAC
3000 VDC	2400 VDC	1500 VAC
4000 VDC	3200 VDC	2000 VAC
5000 VDC	4000 VDC	2500 VAC
6000 VDC	4800 VDC	3000 VAC

Table 1 : D.C. Isolation Voltage test vs different conditions

Isolation Test Voltage (1 second)	Isolation Test Voltage (1 minute)	Isolation Test Voltage (1 minute)
500 VAC	350 VAC	565 VDC
1000 VAC	700 VAC	1130 VDC
1500 VAC	1050 VAC	1695 VDC
2000 VAC	1400 VAC	2260 VDC
2500 VAC	1750 VAC	2825 VDC
3000 VAC	2100 VAC	3390 VDC
4000 VAC	2800 VAC	4520 VDC
5000 VAC	3500 VAC	5650 VDC
6000 VAC	4200 VAC	6780 VDC

Table 2: A.C. Isolation Voltage test vs different conditions

Isolation mode in IGBT driver circuits

An application for DC/DC converters is to isolate driver circuits for IGBT stacks. In these applications, the maximum DC voltage applied across the isolation gap is not the only factor to be considered because the highly dynamic switching waveforms are an additional stressing factor (typical switching transients can exceed $20\text{kV}/\mu\text{s}$.) Taking into account that both factors mean a permanent stress on the converter, it is recommended to over specify the converter in terms of isolation voltage and coupling capacitance.

Even if a 3kVDC product seems to be appropriate if you just look at the rated working voltage that is required, it is still recommended to choose a product which is specified to 5.2kVDC or 6kVDC to also cover the high dv/dt rates. The higher the isolation voltage rating for a DC/DC converter is, the lower the coupling (isolation) capacitance and a low coupling capacitance is essential in AC or highly dynamic switched DC usage. This will ensure a safe usage and avoid a shortened lifetime in such a highly demanding situation.

In the example below, A RP-0524S is used to provide a 5200V isolated supply for the high side drivers and a second, non-isolated converter is used to boost the 5V supply voltage up to 15V for the low side drivers.

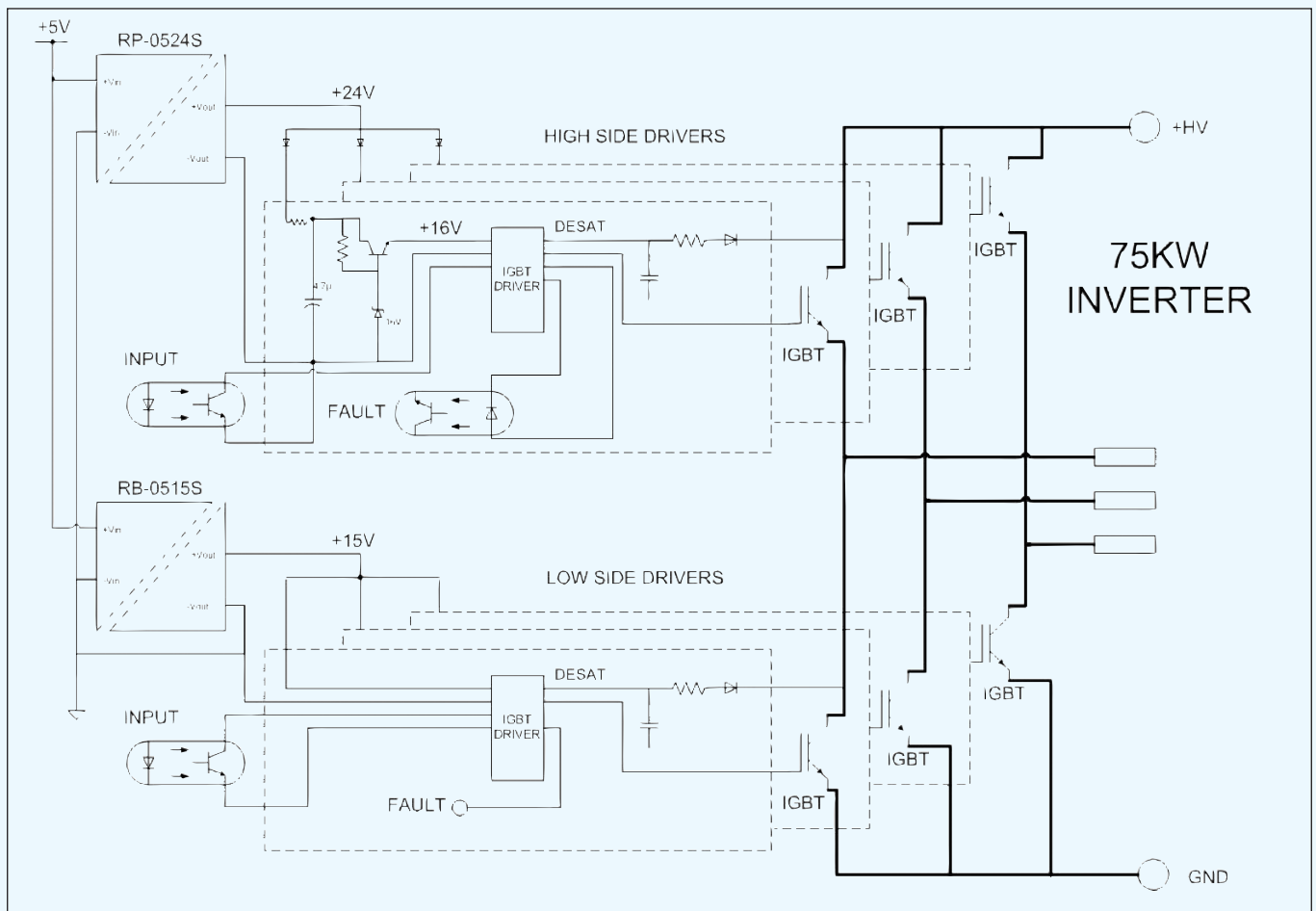

Connecting

DC-DC Converters in Series

Galvanic isolation of the output allows multiple converters to be connected in series, simply by connecting the positive output of one converter to the negative of another (see figure 3). In this way non-standard voltage rails can be generated, however, the current output of the highest output voltage converter should not be exceeded.

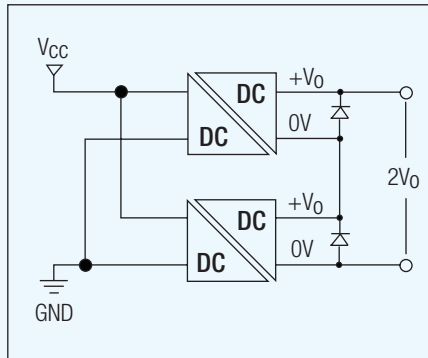

Figure 3: Connecting DC-DC Converters in Series

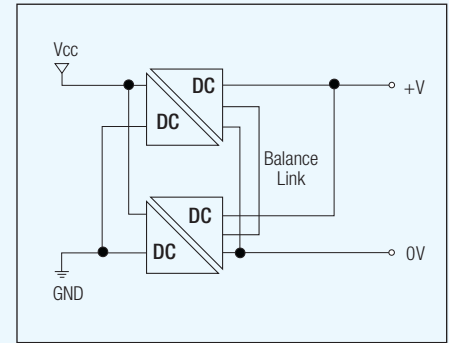

Figure 4: Paralleled DC-DC Converters with Balance Function.

When converters are connected in series, additional filtering is strongly recommended, as the converters switching circuits are not synchronised. As well as a summation of the ripple voltages, the output could also produce relatively large beat frequencies. A capacitor across the output will help, as will a series inductor (see filtering).

Connecting

DC-DC Converters in Parallel

Connecting the outputs of DC/DC converters in parallel is possible but not recommended. Usually DC/DC converters have no possibility to balance out the output currents.

So there is potential danger that if the loading is asymmetrical, that one of the converters starts to be overloaded while the others have to deliver less current. The over-loaded converter may then drop out of circuit leading to power supply oscillation.

The only possibility to balance out the individual currents is to use a special balance function (like in R-5xxx) or use converters with SENSE function and additional load-share controllers (as can be done for the RP40-SG and RP60-SG, for example). Refer to figure 5 below.

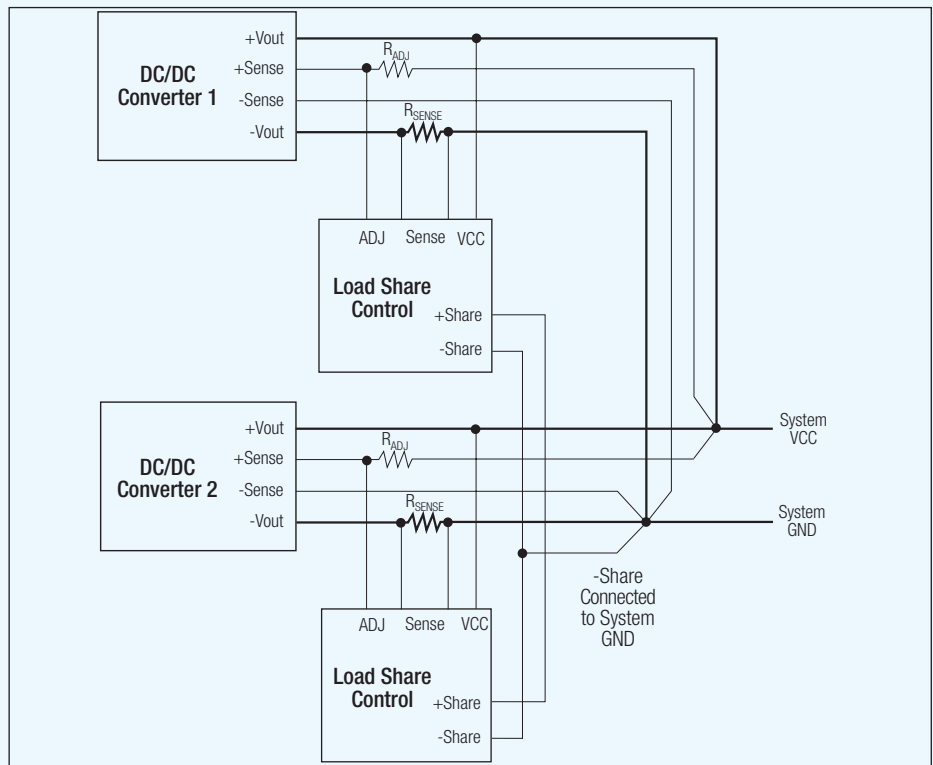

Figure 5: Paralleled DC-DC Converters using Load Share Controllers

If two or more converters are operated from a common supply voltage (inputs in parallel), then input decoupling via LC-filters is recommended (see input filters in figure 5). This helps to avoid hard-to-handle conducted EMI caused by totally un-synchronized oscillators. Also inrush current peaks are lowered. Having several smaller filters, one for each converter, is recommended instead of using one common filter for all converters, as this helps to reduce the possibility of the converters beating against each other.

Chaining DC-DC Converters

Connecting the output of one DC/DC converter to the input of a second converter is sometimes a very useful technique. For example, the benefits of the very wide input voltage range of the innoLine series can be combined with the high isolation of the econoLine series to create

a combination converter which is both isolated and with an exceptionally wide 7:1 input voltage range.

Similarly, an isolated DC/DC converter can be used to power an R-78 switching regulator to provide dual positive outputs with non-standard voltages.

In every case, some care has to be taken concerning the inrush current of the second converter in the chain. If the peak inrush current is too high, then the first converter in the chain may not start up.

The solution to this problem is to add some capacitance to supply the peak inrush current and/or to delay the start-up of the second converter in the chain.

Figure 5a shows some typical examples.

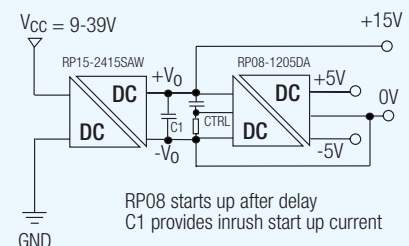
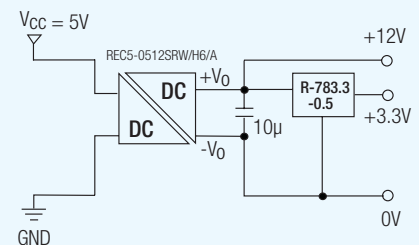

Figure 5a: Chained DC-DC Converter Examples

Filtering

When reducing the ripple from the converter, at either the input or the output, there are several aspects to be considered. Recom recommends filtering using simple passive LC networks at both input and output (see figure 6). A passive RC network could be used, however, the power loss through a resistor is often too high. The self-resonant frequency of the inductor needs to be significantly higher than the characteristic frequency of the device (typically 100kHz for Recom DC-DC converters). The DC current rating of the inductor also needs consideration, a rating of approximately twice the supply current is recommended.

The DC resistance of the inductor is the final consideration that will give an indication of the DC power loss to be expected from the inductor.

Output Filtering calculation:

Calculating of the filtering components can be

$$f_c = \frac{1}{2\pi\sqrt{L_{OUT}C_0}}$$

done using

This frequency should be significant lower than the switching frequency of the converter.

Example - RC series:

Operating frequency = 85kHz max.

then, $f_c = 10\%$ of 85 kHz = 8,5 kHz

$$f_c = \frac{1}{2\pi\sqrt{L_{OUT}C_0}}$$

$$f_c = 8,5 \text{ kHz} = \frac{1}{2\pi\sqrt{L_{OUT}C_0}}$$

for:

$$L_{OUT} = 470 \mu\text{H}$$

$$C_0 = \left(\frac{1}{(2\pi f_c)^2 L_{OUT}} \right) = \left(\frac{1}{(2\pi \cdot 8,5 \text{ kHz})^2 \cdot 470 \mu\text{H}} \right) = 745 \text{ nF}$$

However, depending on your application design and loadsituation may interfere with the calculated filter so testing in the final application and re-adjustment of the component's values may be necessary.

When choosing a value for the filtering capacitor please take care that the maximum capacitive load is within the specifications of the converter.

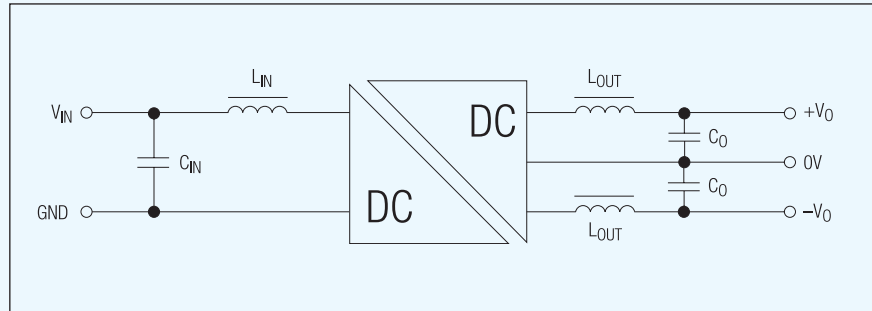

Figure 6: Input and Output Filtering

Common Mode Chokes

Better results in filtering can be achieved if common mode chokes are used instead of a single choke.

Common mode chokes are multiple chokes sharing a core material so the common mode rejection (Electrical noise which comes through one power line and returns to the noise source through some type of ground path is common mode noise.) is higher.

Please refer to our page "Common Mode Chokes for EMC" also part of these application notes. These can be used for input filtering as well as for the output side.

Limiting Inrush Current

Using a series inductor at the input will limit the current that can be seen at switch on (see figure 7).

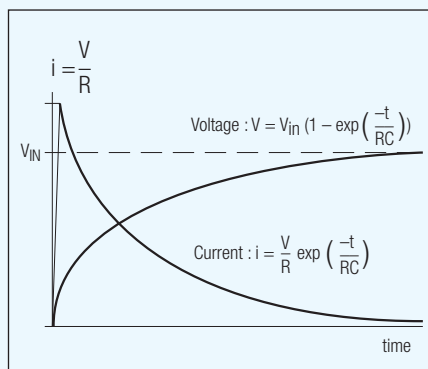

Figure 7: Input Current & Voltage at Switch On

If we consider the circuit without the series inductor, then the input current is given by;

$$i = \frac{V}{R} \exp\left(\frac{-t}{RC}\right)$$

When the component is initially switched on (i.e. $t=0$) this simplifies to;

$$i = \frac{V}{R}$$

This would imply that for a 5V input, with say 50mOhm track and wire resistance, the inrush current could be as large as 100A. This could cause a problem for the DC-DC converter.

A series input inductor therefore not only filters the noise from the internal switching circuit, but also limits the inrush current at switch on. A typical value for an input inductor used to reduce the inrush current is 1mH or higher.

A typical value for an inductor used to filter the input is 50-300μH. So although the circuit diagram may look similar, the input inductors have very different functions and different values.

If a common mode choke is used as an inrush current limiter, it has the added advantage over a single inductor that the inrush currents flowing in the two windings cancel out and the ferrite is less likely to go into saturation.

Short Circuit Protection in 0.25W - 2W Econoline converters

In the low wattage, unregulated converter Portfolio we offer continuous short circuit protection (option /P). Especially in applications where the output of converters is connected via a plug and socket to an external module, the chances of having a short circuit across the output is quite high. A conventional unregulated converter can withstand a short circuit across the outputs for only a limited time. The same condition can occur with high capacitive loads if they have a low ESR.

RECOM uses balancing between transformer core saturation ratings and the maximum electrical ratings of the switching transistors in the primary side oscillator to create a converter that can withstand a continuous short circuit (<1 Ohm) across the outputs without failing.

However, this is NOT an overload protection. If the converters are over-loaded but not short circuited, the converters may still overheat and fail.

Maximum Output Capacitance

A simple method of reducing the output ripple is simply to add a large external capacitor. This can be a low cost alternative to the LC filter approach, although not as effective. There is, however, also the possibility of causing start up problems, if the output capacitance is too large.

With a large output capacitance at switch on, there is no charge on the capacitors and the DC-DC converter immediately experiences a large current demand at its output. The inrush current can be so large as to exceed the ability of the DC-DC converter, and the device can go into current limit or an undefined mode of operation. In the worst case scenario the device continuously oscillates as it tries to start, goes into overload shutdown and then retries again.

The DC-DC converter may not survive if this condition persists.

For the Powerline the maximum capacitive loads are specified. For Econoline please refer to the tables below.

If instead of single capacitors on outputs an L-C-filter is used, the maximum capacitive load can be higher because the choke is preventing too high rising speed of the current peak. However the practical maximum capacitive load is dependent on the quality of the filter and the ESR of the capacitors used.

Settling Time

The main reason for not fitting a series inductor internally, apart from size constraints, is that many applications require a fast switch on time. When the input voltage is a fast ramp,

then the output can respond within 500µs of the input reaching its target voltage (measured on a range of RA/RB and RC/RD converters under full output load without external filters). The use of external filters and additional input or output capacitance will slow this reaction time. It is therefore left to the designer to decide on the predominant factors important for their circuit: settling time or noise performance.

Isolation Capacitance and Leakage Current

The isolation barrier within the DC-DC converter has a capacitance, which is a measure of the coupling between input and output circuits. Providing this is the largest coupling source, a calculation of the leakage current between input and output circuits can be calculated.

	Single Output	Dual Output
Unregulated 0.25W Unregulated 0.5W	22µF max.	
Unregulated 1W Regulated 0.5W	33µF max.	10µF max.
Unregulated 2W Regulated 1W	47µF max.	33µF max.

Max. capacitive load for unregulated Econoline models

		Max. capacitive load	
3W , 5W	Single output	3.3V	2200µF
		5.0V	1000µF
		9.0V	470µF
		12.0V	220µF
		15.0V	120µF
	Dual output	±5.0V	±470µF
		±9.0V	±220µF
		±12.0V	±100µF
		±15.0V	±68µF

Max. capacitive load for REC3 and REC5 series

		Max. capacitive load	
7.5W	Single output	3.3V	3300µF
		5.0V	2200µF
		9.0V	680µF
		12.0V	330µF
		15.0V	220µF
	Dual output	±5.0V	±1000µF
		±9.0V	±330µF
		±12.0V	±160µF
		±15.0V	±100µF

Max. capacitive load for REC7.5 series

Assuming we have a known isolation capacitance (C_{is} - refer to datasheet) and a known frequency for either the noise or test signal, then the expected leakage current (I_L) between input and output circuits can be calculated from the impedance.

The general isolation impedance equation for a given frequency (f) is given by:

$$Z_f = \frac{1}{j2\pi C_{is} f}$$

For an RB-0505D, the isolation capacitance is 18pF, hence the isolation impedance to a 50Hz test signal is:

$$Z_{50} = \frac{1}{j2\pi \cdot 50 \cdot 18 \text{ pF}} = 177 \text{ M}\Omega$$

If using a test voltage of 1kVrms, the leakage current is:

$$I_L = \frac{V_{test}}{Z_f} = \frac{1000V}{177 \text{ M}\Omega} = 5.65 \mu A$$

It can be easily observed from these simple equations that the higher the test or noise voltage, the larger the leakage current, also the lower the isolation capacitance, the lower the leakage current. Hence for low leakage current, high noise immunity designs, high isolation DC-DC converters should be selected with an appropriate low isolation capacitance.

Application Examples Overload Protection

Although the use of filtering will prevent excessive current at power-on under normal operating conditions, many of the lower cost converters have no protection against an output circuit taking excessive power or even going short-circuit. When this happens, the DC-DC converter will take a large input current to try to supply the output. Eventually the converter will overheat and destroy itself if this condition is not rectified (short circuit overload duration is only for 1s on a standard unregulated part).

There are several ways to prevent overload at the outputs destroying the DC-DC converter. The simplest being a straight forward fuse. Sufficient tolerance for inrush current is required to ensure the fuse does not blow on power-on (see figure 8). Another simple scheme that can be applied is a circuit breaker.

There is also the potential to add some intelligence to the overload scheme by either detecting the input current, or the output voltage (see figure 9).

If there is an intelligent power management system at the input, using a series resistor (in place of the series inductor) and detecting the voltage drop across the device to signal the management system can be used. A similar scheme can be used at the output to determine the output voltage, however, if the management system is on the input side, the signal will need to be isolated from the controller to preserve the system isolation barrier (see figure 10).

There are several other current limiting techniques that can be used to detect an overload situation, the suitability of these is left to the designer. The most important thing to consider is how this information will be used. If the system needs to signal to a controller the location or module causing the overload, some form of intelligence will be needed. If the device simply needs to switch off, a simple fuse type arrangement will be adequate.

Unregulated RECOM DC/DC converters usually are short circuit protected only for a short time, e.g. 1 second. By option they can be continuous short circuit protected (option /P), then their design is able to withstand the high output current in a short circuit situation without any need for extra circuit protection. All ReCom DC-DC converters which include an internal linear regulator have a thermal overload shut-down condition which protects these devices from excessive over-load.

If this condition is to be used to signal a power management system, the most suitable arrangement is the output voltage detector (see figure 10a), since this will fall to near zero on shut-down. Wide input range regulated converters offer overload protection / short circuit protection via an internal circuit that interferes with the primary oscillator so the switching is regulated back in situations of overload or output short circuit.

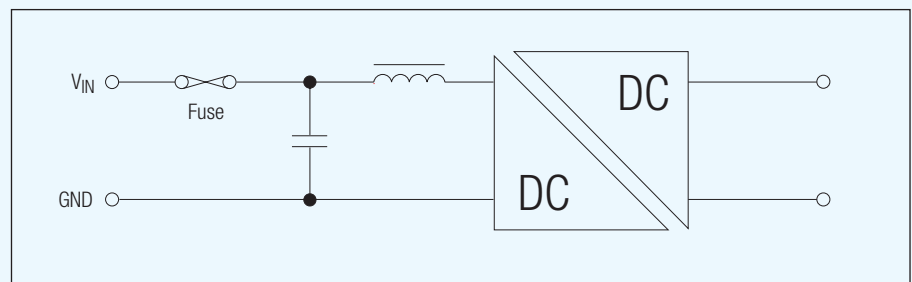

Figure 8: Simple Overload Protection

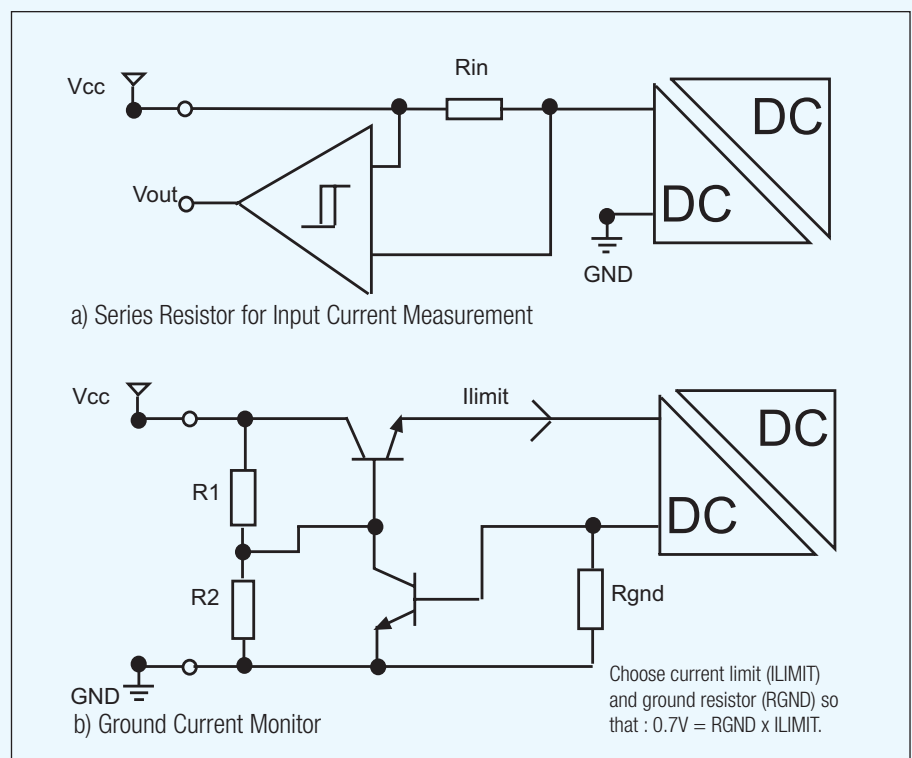

Figure 9: Input Monitored Overload Protection

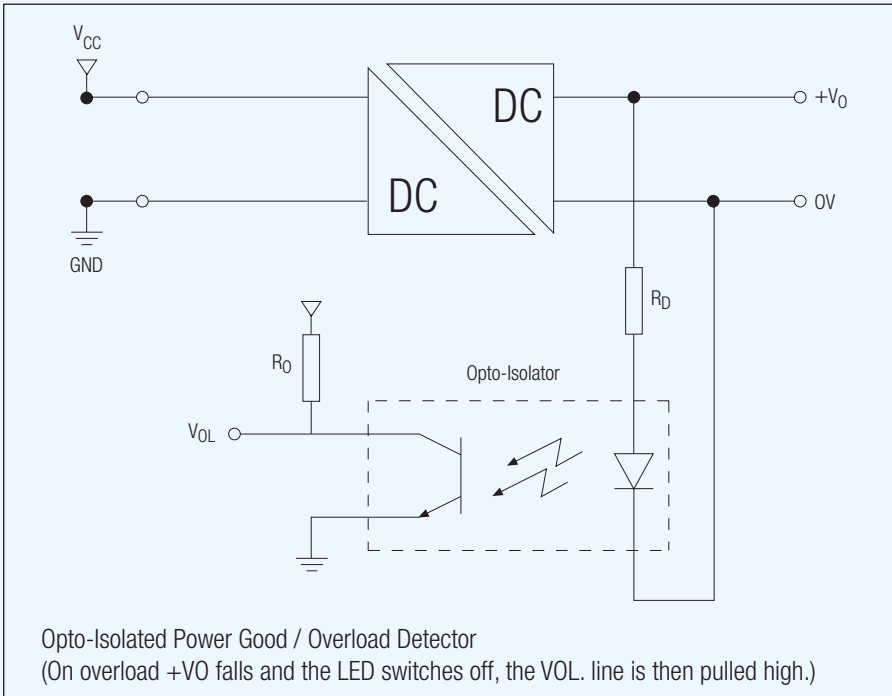

Figure 10 : Output Monitored Overload Protection

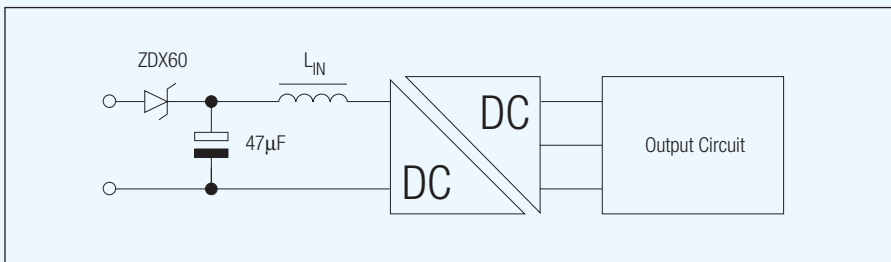

Figure 11 : Input Voltage Drop-out

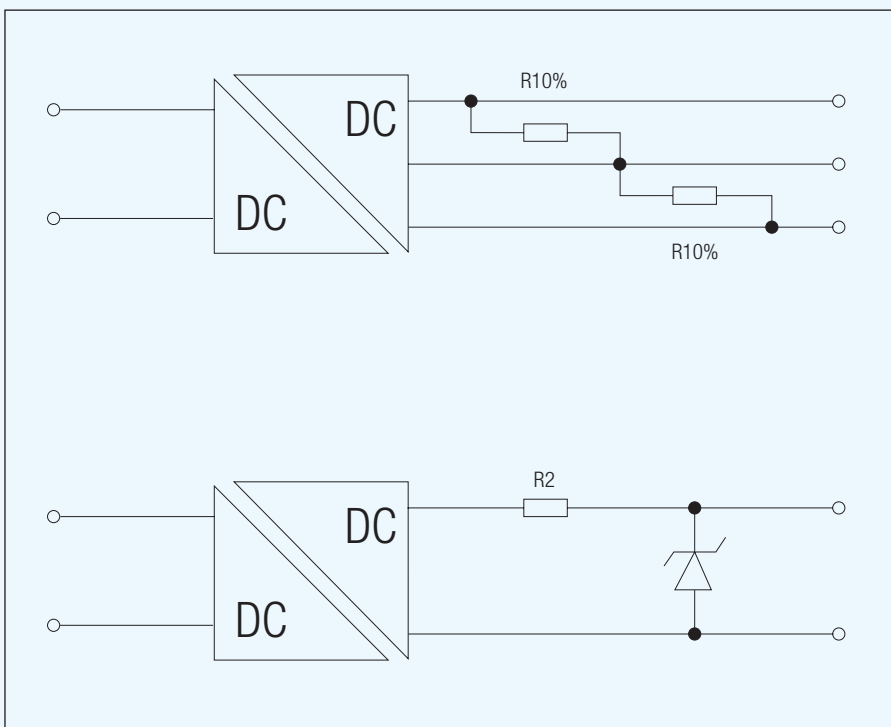

Figure 12: No Load over Voltage Lock-Out

Input Voltage Drop-Out (brown-outs)

When the input voltage drops, or is momentarily removed, the output circuit would suffer similar voltage drops. For short period input voltage drops, such as when other connected circuits have an instantaneous current demand, or devices are plugged in or removed from the supply rail while 'hot', a simple diode-capacitor arrangement can prevent the output circuit from being effected.

The circuit uses a diode feed to a large reservoir capacitor (typically 47µF electrolytic), which provides a short term reserve current source for the converter, the diode blocking other circuits from draining the capacitor over the supply rail. When combined with an in-line inductor this can also be used to give very good filtering. The diode volt drop needs to be considered in the power supply line under normal supply conditions. A low drop Schottky diode is recommended (see figure 11).

No Load Over Voltage Lock-Out

Unregulated DC-DC converters are expected to be under a minimum of 10% load, hence below this load level the output voltage is undefined. In certain circuits this could be a potential problem.

The easiest way to ensure the output voltage remains within a specified tolerance, is to add external resistors, so that there is always a minimum 10% loading on the device (see figure 12). This is rather inefficient in that 10% of the power is always being taken by this load, hence only 90% is available to the additional circuitry.

Zener diodes on the output are another simple method. It is recommended that these be used with a series resistor or inductor, as when the Zener action occurs, a large current surge may induce signal noise into the system.

Long Distance Supply Lines

When the supply is transmitted via a cable, there are several reasons why using an isolated DC-DC converter is good design practice (see figure 13). The noise pick up and EMC susceptibility of a cable is high compared to a PCB track. By isolating the cable via a DC-DC converter at either end, any cable pick-up will appear as common mode noise and should be self-cancelling at the converters.

Another reason is to reduce the cable loss by using a high voltage, low current power transfer through the cable and re-converting at the terminating circuit. This will also reduce noise and EMC susceptibility, since the noise voltage required to affect the rail is also raised.

For example, compare a system having a 5V supply and requiring a 5V, 500mW output at a remote circuit. Assume the connecting cable has a 100 Ohm resistance. Using an RO-0505 to convert the power at either end of the cable, with a 100mA current, the cable will lose 1W (I^2R) of power. The RO would not be suitable, since this is its total power delivery; hence there is no power available for the terminating circuit. Using a RB-0512D to generate 24V and a RO-2405S to regenerate the 5V, only a 21 mA supply is required through the cable, a cable loss of only 44mW.

LCD Display Bias

A LCD display typically requires a positive or negative 24V supply to bias the crystal. The RO-0524S converter was designed specifically for this application. Having an isolated 0V output, this device can be configured as a +24V supply by connecting this to the GND input, or a -24V supply by connecting the +Vo output to GND (see figure 14).

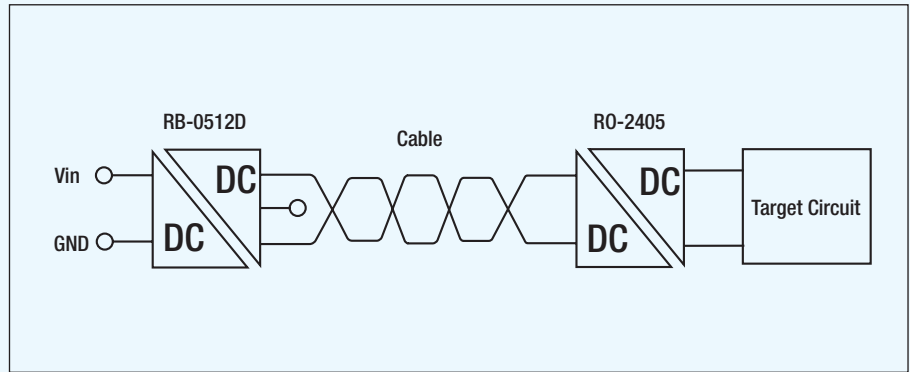

Figure 13: Long Distance Power Transfer

Pre- and Post Regulation

The usefulness of many DC-DC converters can be enhanced by pre- or post-regulation.

The usual input voltage range of a DC-DC converter is either fixed, 2:1 or 4:1 depending on the converter technology used inside the device. Switching regulators have typically a much wider input voltage range - up to 8:1, but do not have the advantage of the DC-DC converter's galvanic isolation. By combining the two techniques and using a switching regulator as a pre-regulator, an ultra-wide range, isolated DC-DC converter supply can be built (see Figure 15a)

Post regulation is useful to combine the advantages of a linear regulator's low noise output with the ability of a DC-DC converter to boost a lower input voltage to a higher output voltage.

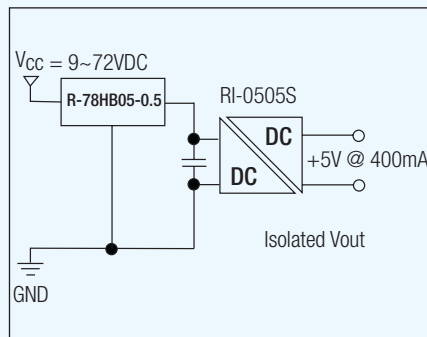

Figure 15a: Pre-Regulation Example

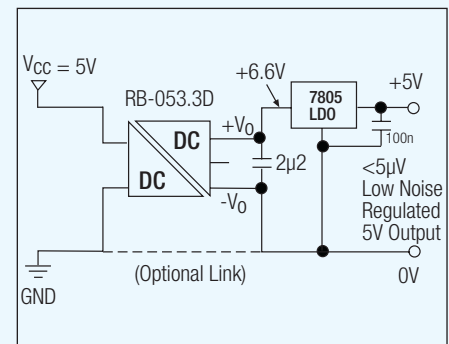

Figure 15b: Post-Regulation Example

In this example, a low cost RAA unregulated converter is used to boost a 5V supply up to 10V so that a low drop out linear regulator can produce a low noise, regulated 9V output.

EIA-232 Interface

In a mains powered PC often several supply rails are available to power a RS232 interface. However, battery operated PC's or remote equipment having a RS232 interface added later, or as an option, may not have the supply rails to power a RS232 interface. Using a RB-0512S is a simple single chip solution, allowing a fully EIA-232 compatible interface to be implemented from a single 5V supply rail, and only 2 additional components (see figure 16a).

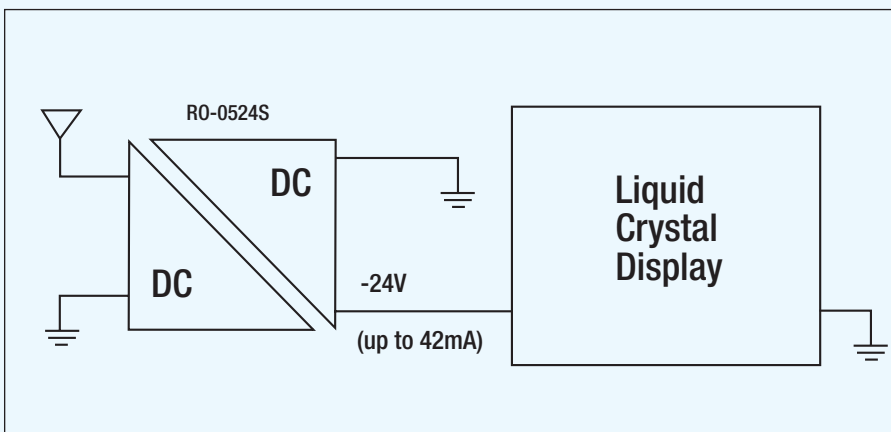

Figure 14: LCD Display Bias

3V/5V Logic Mixed Supply Rails

There has been a lot of attention given to new I.C.'s and logic functions operating at what is rapidly emerging as the standard supply level for notebook and palmtop computers. The 3.3V supply is also gaining rapid acceptance as the defacto standard for personal telecommunications, however, not all circuit functions required are currently available in a 3.3V powered IC. The system designer therefore has previously had only two options available; use standard 5V logic or wait until the required parts are available in a 3.3V form, neither being entirely satisfactory and the latter possibly resulting in lost market share.

There is now another option, mixed logic functions running from separate supply rails. A single 3.3V line can be combined with a range of DC-DC converters from Recom, to generate voltage levels to run virtually any standard logic or interface IC.

The Recom range includes dual output parts for powering analogue bipolar and amplifier functions (RB series), as well a single output function for localised logic functions (RL/RM, RN/RO series). A typical example might be a RS232 interface circuit in a laptop PC using a 3.3V interface chip (such as the LT1330), which accepts 3.3V logic signals but requires a 5V supply (see figure 16b). Recom has another variation on this theme and has developed two 5V to 3.3V step down DC-DC converters (RL-053.3 and RO-053.3). These have been designed to allow existing systems to start incorporating available 3.3V I.C.'s without having to redesign their power supply.

This is particularly important when trying to reduce the overall power demand of a system, but not having available all of the functions at the 3.3V supply.

The main application for this range of devices are system designers, who want to provide some functionality that requires a higher voltage than is available from the supply rail, or for a single localised function. Using a fully isolated supply is particularly useful in interface functions and systems maintaining separate analogue and digital ground lines.

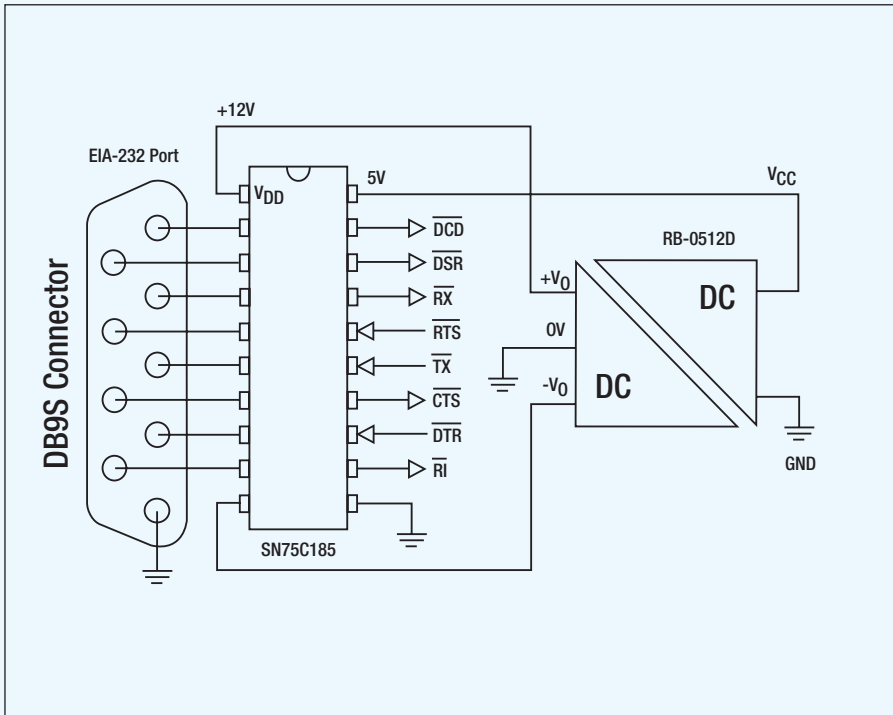

Figure 16a: Optimised RS232 Interface

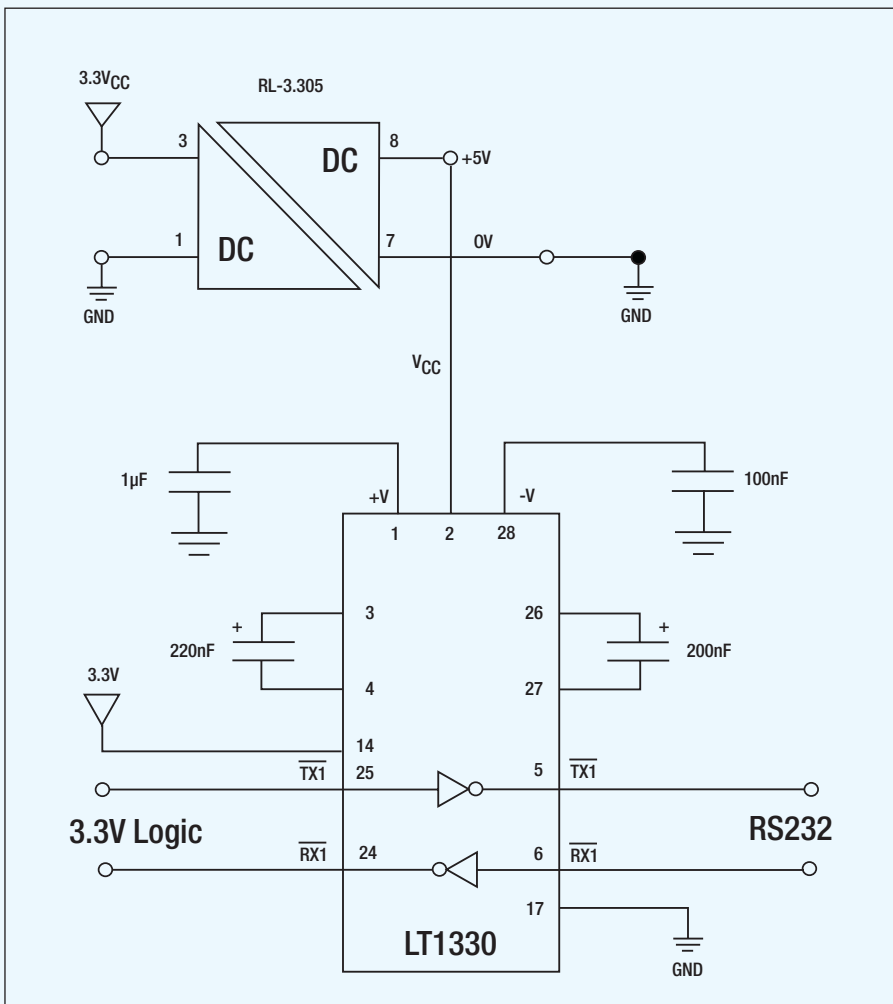

Figure 16b: RS232 Interface with 3V Logic

Isolated Data Acquisition System

Any active system requiring isolation will need a DC-DC converter to provide the power transfer for the isolated circuit. In a data acquisition circuit there is also the need for low noise on the supply line; hence good filtering is required. The circuit shown (see figure 17) provides a very high voltage isolation barrier by using an RH converter to provide the power isolation and opto isolators for the data isolation. An overall system isolation of 2.5kV is achieved.

EMC Considerations: When used for isolating a local power supply and incorporating the appropriate filter circuits as illustrated in Fig. 17), DC-DC converters can present simple elegant solutions to many EMC power supply problems. The range of fixed frequency DC-DC converters is particularly suitable for use in EMC problem situations, as the stable fixed switching frequency gives easily characterised and easily filtered output. The following notes give suggestions to avoid common EMC problems in power supply circuits.

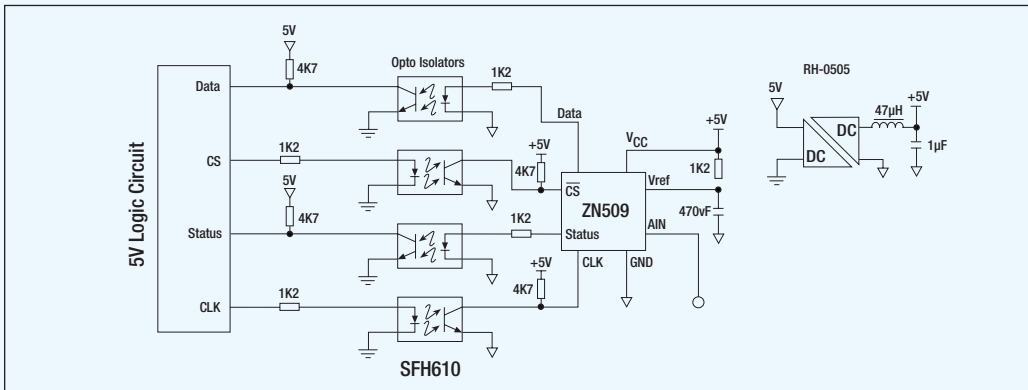

Figure 17: Isolated Serial ADC System

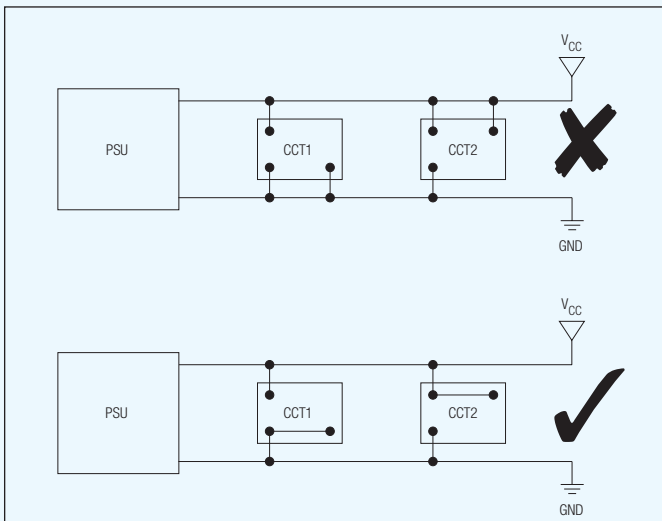

Figure 18: Eliminate Loops in Supply Line

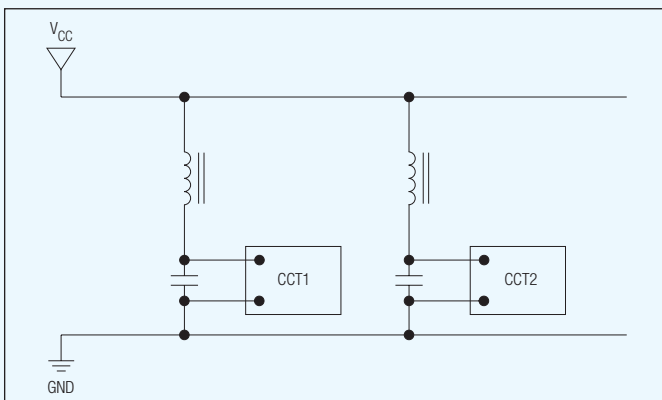

Figure 19: Decouple Supply Lines at Local Boundaries

Power Supply Considerations

- Eliminate loops in supply lines (see figure 18).
 - Decouple supply lines at local boundaries (use LC filters with low Q, see figure 19).
 - Place high speed sections close to the power line input, slow speed sections furthest away (reduces power plane transients, see figure 20).
 - Isolate individual systems where possible (especially analogue and digital systems) on both power supply and signal lines (see figure 21).
- An isolated DC-DC converter can provide a significant benefit to help reduce susceptibility and conducted emission due to the isolation of both power rail and ground from the system supply. Recom primarily uses toroidal transformers in our DC-DC converters and as such they have negligible radiated EMI, but all DC-DC converters are switching devices and as such will have a characteristic switching frequency, which may need some additional filtering.

Interpretation of DC-DC Converter EMC Data

Electromagnetic compatibility (EMC) of electrical and electronic products is a measure of electrical pollution. Throughout the world there are increasing statutory and regulatory requirements to demonstrate the EMC of end products. In Europe the EC directive 89/336/EEC requires that any product sold after 1 January 1996 complies with a series of EMC limits, otherwise the product will be prohibited from sale within the EEC and the seller could be prosecuted and fined.

Although DC-DC converters are generally exempt from EMC restrictions on the grounds that they are components, it is the belief of Recom that information on the EMC of these components can help designers plan ahead so that their end products can meet the relevant statutory EMC requirements. It must be remembered however, that a DC-DC converter is unlikely to be the only component in the power supply chain, hence the information quoted needs interpretation by the circuit designer to determine its impact on the final EMC performance of their system.

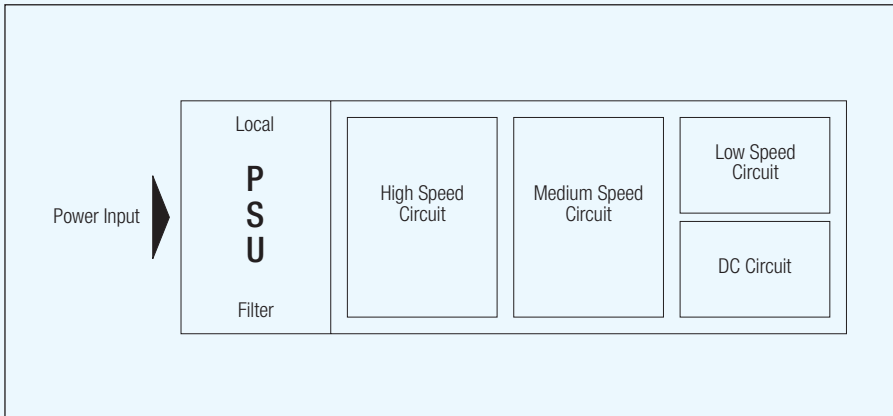

Figure 20: Place High Speed Circuit Close to PSU

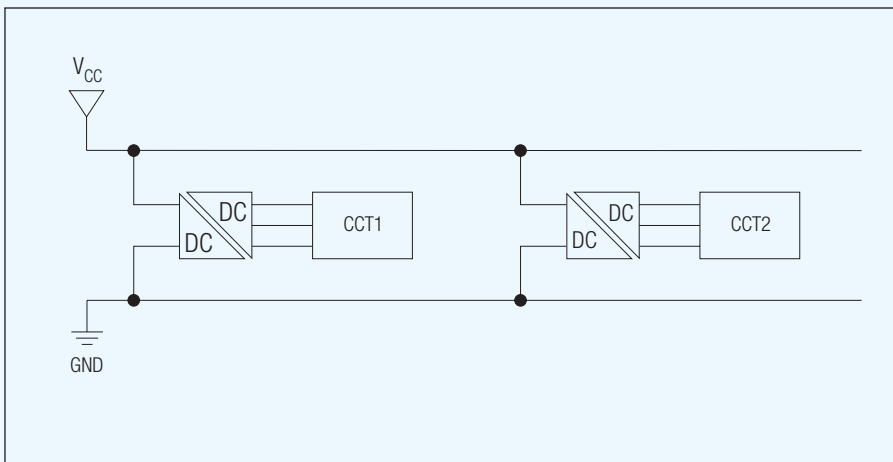

Figure 21 : Isolate Individual Systems

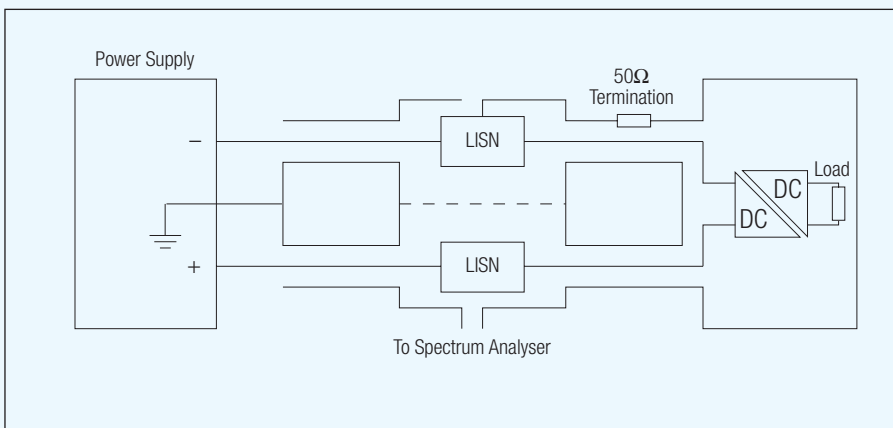

Figure 22: Filtered Supply to DC-DC Converter

The notes given here are aimed at helping the designer interpret the effect the DC-DC converter will have on the EMC of their end product, by describing the methods and rationale for the measurements made. Where possible CISPR and EN standards have been used to determine the noise spectra of the components, however, all of the standards reference to mains powered equipment and interpretation of these specifications is necessary to examine DC supplied devices.

Conducted and Radiated Emissions

There are basically two types of emissions covered by the EC directive on EMC: radiated and conducted. Conducted emissions are those transmitted over wire connecting circuits together and covers the frequency spectrum 150kHz to 30MHz. Radiated are those emissions transmitted via electromagnetic waves in air and cover the frequency spectrum 30MHz to 1GHz.

Hence, the EC directive covers the frequency spectrum 150kHz to 1GHz, but as two separate and distinct modes of transmission.

The Recom range of DC-DC converters feature toroidal transformers. These have been tested and proved to have negligible radiated noise. The low radiated noise is primarily due to toroidal shaped transformers maintaining the magnetic flux within the core, hence no magnetic flux is radiated by design. Due to the exceptionally low value of radiated emission, only conducted emissions are quoted.

Conducted emissions are measured on the input DC supply line. Unfortunately no standards exist for DC supplies, as most standards cover mains connected equipment. This poses two problems for a DC supplied device, firstly no standard limits can be directly applied, since the DC supplied device does not directly connect to the mains, also all reference material uses the earth-ground as a reference point. In a DC system often the 0V is the reference, however, for EMC purposes, it is probably more effective to maintain the earth as the reference, since this is likely to be the reference that the shielding is connected to. Consequently all measurements quoted are referenced to the mains borne earth.

Line Impedance Stabilisation Network (LISN)

It is necessary to ensure that any measurement of noise is from the device under test (DUT) and not from the supply to this device. In mains connected circuits this is important and the mains has to be filtered prior to supply to the DUT. The same approach has been used in the testing of DC-DC converters and the DC supply to the converter was filtered, to ensure that no noise from the PSU as present at the measuring instrument.

A line impedance stabilisation network (LISN) conforming to CISPR 16 specification is connected to both positive and negative supply rails and referenced to mains earth (see figure 22). The measurements are all taken from the positive supply rail, with the negative rail measurement point terminated with 50 Ohm to impedance match the measurement channels.

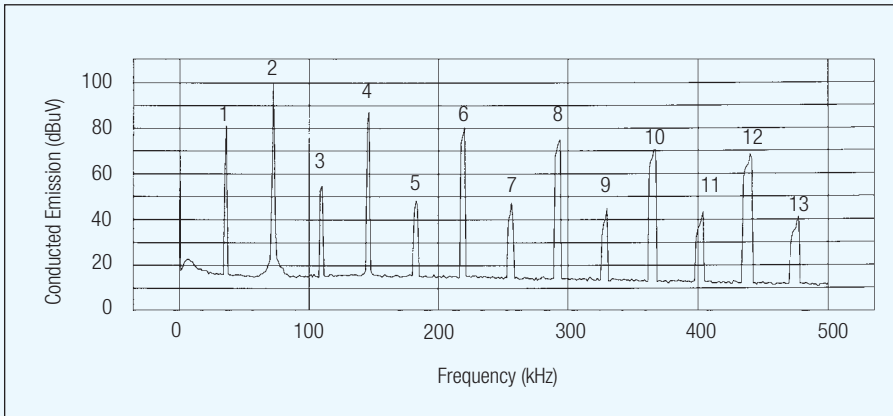

Figure 23: Individual Line Spectra

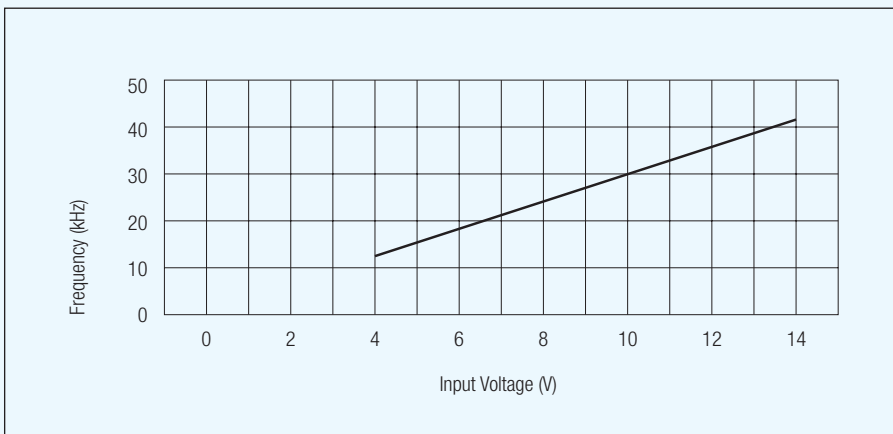

Figure 24: Frequency Voltage Dependency

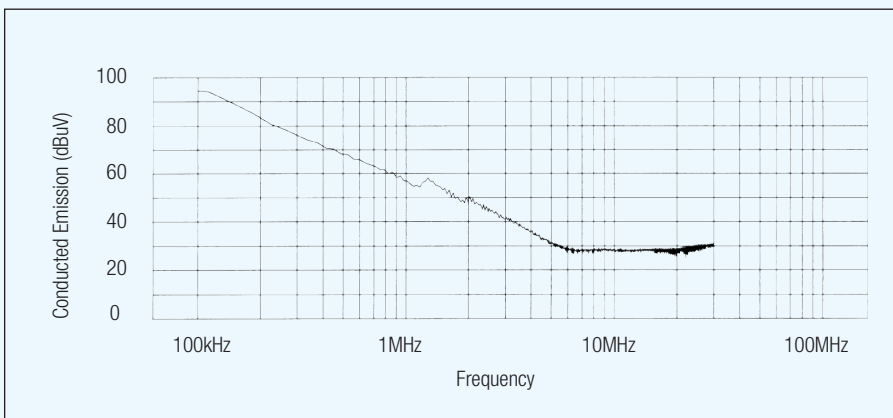

Figure 25 : V Spectrum

Shielding

At all times the DUT, LISN's and all cables connecting any measurement equipment, loads and supply lines are shielded. The shielding is to prevent possible pick-up on cables and DUT from external EMC sources (e.g. other equipment close by). The shielding is referenced to mains earth (see figure 22).

Line Spectra of DC-DC Converters

All DC-DC converters are switching devices, hence, will have a frequency spectra.

Fixed input DC-DC converters have fixed switching frequency, for example the RC/RD range of converters has a typical switching frequency of 50kHz. This gives a stable and predictable noise spectrum regardless of load conditions.

If we examine the noise spectrum closely (see figure 23) we can see several distinct peaks, these arise from the fundamental switching frequency and its harmonics (odd line spectra)

and the full rectified spectra, at twice the fundamental switching frequency (even line spectra). Quasi-resonant converters, such as the Recom range, have square wave switching waveforms, this produces lower ripple and a higher efficiency than soft switching devices, but has the drawback of having a relatively large spectrum of harmonics.

The EC regulations for conducted interference covers the bandwidth 150kHz to 30MHz. Considering a converter with a 100kHz nominal switching frequency, this would exhibit 299 individual line spectra. There will also be a variation of absolute switching frequency with production variation, hence a part with a 90kHz nominal frequency would have an additional 33 lines over the entire 30MHz bandwidth. Absolute input voltage also produces slight variation of switching frequency (see figure 24). Hence, to give a general level of conducted noise, we have used a 100kHz resolution bandwidth (RBW) to examine the spectra in the data sheets. This wide RBW gives a maximum level over all the peaks, rather than the individual line spectra. This is easier to read as well as automatically compensating for variances in switching frequency due to production variation or differences in absolute input voltage (see figure 25).

The conducted emissions are measured under full load conditions in all cases. Under lower loads the emission levels do fall, hence full load is the worst case condition for conducted line noise.

Econoline Filters for Conducted and Radiated Emissions

Econoline converters will meet the requirements for FCC / EN55022 Class A and Class B limits for conducted and radiated emissions with the addition of an external filter.

The following filter circuit suggestions are based on EMC tests carried out in an EMC test facility on single converters. Different component values or filter configurations may be required if several converters share a common supply, if different types of converter are used together or if the supply voltage or load is not placed close to the converters.

Econoline EMC Filter Suggestions: Low Power Regulated and Unregulated Converters

EN55022 Class A

(Omit C1, L1 and C3)

RM, RSS, RSD, RNM, ROM, RO, RBM, RB, RE, RK, RH, RN, RTS, RTD, RI, RD, RKZ, RJZ, RZ, RSZ, RY
C2=3.3µF

RP, RxxPxx, RU, RxxP2xx, RUZ, RV
C2=10µF

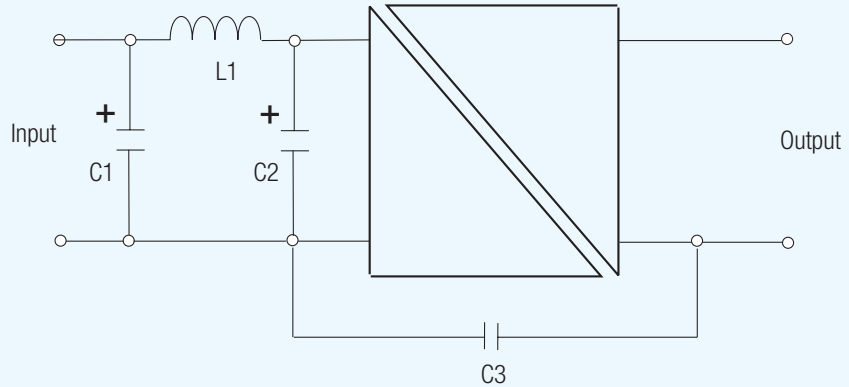

EN55022 Class B

RM, RSS, RSD, RNM, ROM, RO, RBM, RB, RE, RK, RH, RN, RTS, RTD, RI, RD, RKZ, RJZ, RZ, RSZ, RY
C1=10µF, L1 = 470µH, C2=4.7µF, C3 = 2.2nF

RP, RxxPxx, RU, RxxP2xx, RUZ, RV
C1=10µF, L1 = 470µH, C2=10µF, C3 = 2.2nF

EN55022 Class A

(omit C3)

RS0, RS, RW2
 RS3, RW-S, RW-D, REC3-R
C1=10µF, L1 = 1mH, C2=10µF

EN55022 Class B

RS0, RS, RW2
 RS3, RW-S, RW-D, REC3-R
C1=10µF, L1 = 1mH, C2=20µF, C3 = 2.2nF

All capacitors are MLCC

Econoline EMC Filter Suggestion: 3W - 7.5W Regulated Converters

EN55022 Class B

All 2:1 and 4:1
 REC3-REC7.5
 Converters

For details of CMC-08
 common mode choke
 refer to Powerline
 application notes section

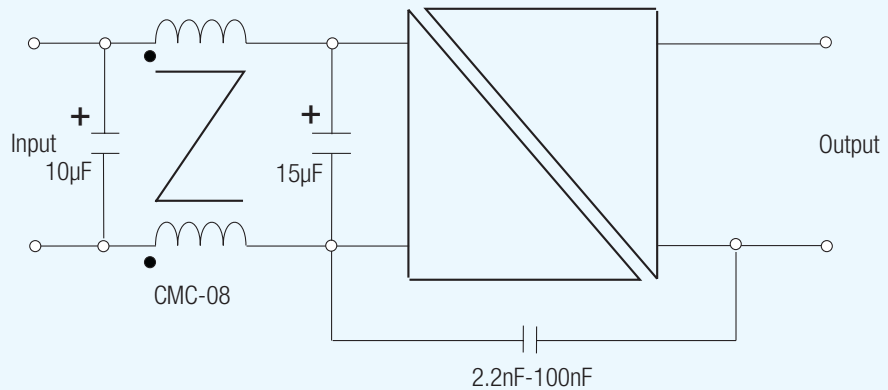

"A" Pinning

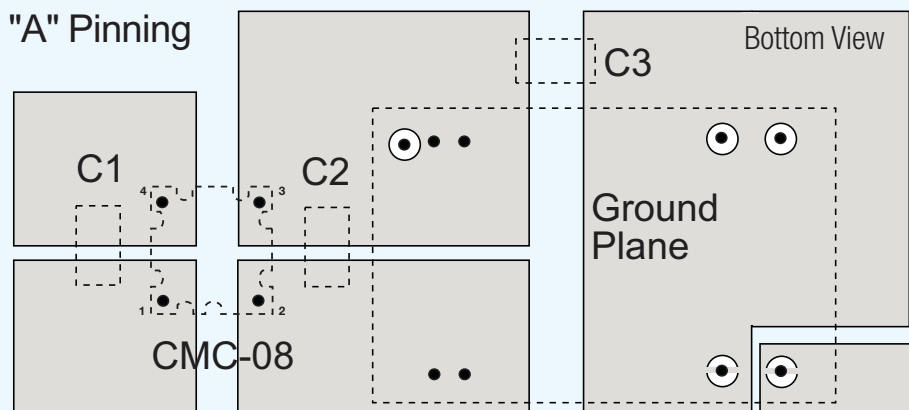

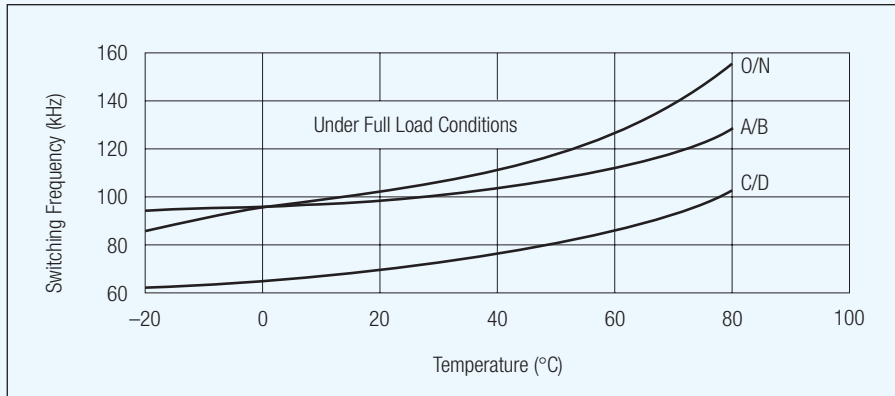

Figure 26: Typical Switching Frequency vs. Temperature

Temperature Performance

The temperature performance of the DC-DC converters detailed in this book is always better than the quoted operating temperature range. The main reason for being conservative on the operating temperature range is the difficulty of accurately specifying parametric performance outside this temperature range.

There are some limiting factors which provide physical barriers to performance, such as the Curie temperature of the core material used in the DC-DC converter (the lowest Curie temperature material in use at Recom is 125°C). Ceramic capacitors are used almost exclusively in the DC-DC converters because of their high reliability and extended life properties, however, the absolute capacity of these can fall when the temperature rises above 85°C (i.e. the ripple will increase). Other considerations are the power dissipation within the active switching components, although these have a very high temperature rating. Their current carrying capacity derates as temperature exceeds 100°C.

Therefore this allows the DC-DC converters to be used above their specified operating temperature, providing the derating of power delivery given in the specification is adhered to. Components operating outside the quoted operating temperature range cannot be expected to exhibit the same parametric performance that is quoted in the specification.

An indication of the stability of a device can be obtained from the change in its operating frequency, as the temperature is varied (see figure 26). A typical value for the frequency variation with temperature is 0.5% per °C, a very low value compared to other commercial parts. This illustrates the ease of filtering of Recom DC-DC converters, since the frequency is so stable across load and temperature ranges.

Surface Mount DC-DC Converters

Production Guideline Application Note

The introduction by Recom of a new and innovative method of encapsulating hybrid DC-DC converters in a transfer moulded (TM) epoxy molding compound plastic has enabled a new range of surface mount (SMD) DC-DC converters to be brought to market, which addresses the component placement with SOIC style handling.

With any new component there are of course new lessons to be learned with the mounting technology. With the Recom SMD DC-DC converters, the lessons are not new as such, but may require different production techniques in certain applications.

Component Materials

Recom SMD converters are manufactured in a slightly different way than the through-hole converters. Instead of potting the PCB board inside a plastic case with conventional epoxy the whole package is molded around the PCB board with epoxy molding compound plastic.

Open frame SMD parts have no moulding compound and the case (when fitted) is provided purely to allow the pick-and-place machine to be able to grip the part and to provide a surface for the part number and datecode. As the parts are not encapsulated, they have more freedom to expand and contract which makes them ideal for vapour phase reflow processes and allows greater flexibility in the temperature profile.

All materials used in RECOM lead-free products are ROHS compliant, thus the total amount of the restricted materials (lead, mercury, cadmium, hexavalent chromium, PBBs and PBDEs) are below the prescribed limits. Detailed chemical analysis reports are available.

Component Placement

Recom SMD DC-DC converters are designed to be handled by placement machines in a similar way to standard SOIC packages. The parts are available either in tubes (sticks) or in reels. The parts can therefore be placed using machines with either vibrational shuttle, gravity feeders, or reel feeders. The vacuum nozzle for picking and placing the components can be the same as used for a standard 14 pin or 18 pin SOIC (typically a 5 mm diameter nozzle). An increase in vacuum pressure may be beneficial, due to the heavier weight of the hybrid compared to a standard SOIC part (a typical 14 pin SOIC weighs 0.1g, the Recom SMD DC-DC converter weighs 1.5 ~ 2,7g).

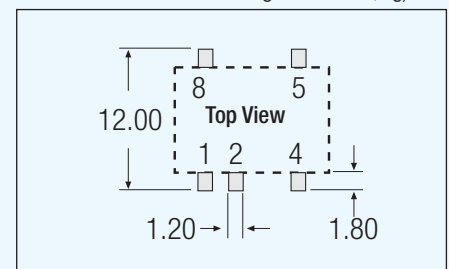

It is advisable to consult your machine supplier on the best choice of vacuum nozzle if in doubt.

If placing these components by hand, handle the components only by the central body area where there are no component pins.

Component Alignment

The components can be aligned by either optical recognition or manual alignment. If using manual alignment it should be ensured that the tweezers press on the component body and not on the pins. The components themselves are symmetrical along their axis, hence relatively easy to align using either method.

Solder Pad Design

The Recom SMD DC-DC converters are designed on a pin pitch of 2,54mm (0.1") with 1,20 mm pad widths and 1,80 mm pad lengths.

This allows pads from one part to be used within a PCB CAD package for forming the pad layouts for other SMD converters. These pads are wider than many standard SOIC pad sizes (0.64mm) and CAD packages may not accommodate these pins with a standard SOIC pad pattern. It should be remembered that these components are power supply devices and as such need broader pads and thicker component leads to minimise resistive losses within the interconnects.

The adhesive prevents the SMD parts being "washed off" in a wave solder, and being "vibrated off" due to handling on a double sided SMD board.

As mentioned previously, the Recom range of SMD DC-DC converters are heavier than standard SOIC devices. The heavier weight is a due to their size (volume) and internal hybrid construction. Consequently the parts place a larger than usual stress on their solder joints and leads if these are the only method of attachment. Using an adhesive between component body and PCB can reduce this stress considerably. If the final system is to be subjected to shock and vibration testing, then using adhesive attachment is essential to ensure the parts pass these environmental tests.

The Recom SMD DC-DC converters all have a stand-off beneath the component for the application of adhesive to be placed, without interfering with the siting of the component. The method of adhesive dispensing and curing, plus requirements for environmental test and in-service replacement will determine suitability of adhesives rather than the component itself. However, having a thermoset plastic body, thermoset epoxy adhesive bonding between board and component is the recommended adhesive chemistry.

If the reflow stage is also to be used as a cure for a heat cure adhesive, then the component is likely to undergo high horizontal acceleration and deceleration during the pick and place operation. The adhesive must be sufficiently strong in its uncured (green) state, in order to keep the component accurately placed.

Adhesive Placement

The parts are fully compatible with the 3 main methods of adhesive dispensing; pin transfer, printing and dispensing. The method of placing adhesive will depend on the available processes in the production line and the reason for using adhesive attachment. For example, if the part is on a mixed through-hole and SMD board, adhesive will have to be placed and cured prior to reflow. If using a SMD only board and heat cure adhesive, the reflow may be used as the cure stage. If requiring adhesive for shock and vibration, but using a conformal coat, then it may be possible to avoid a separate adhesive altogether, and the coating alone provides the mechanical restraint on the component body.

Lead-free Recommended Soldering Profile (SMD parts)

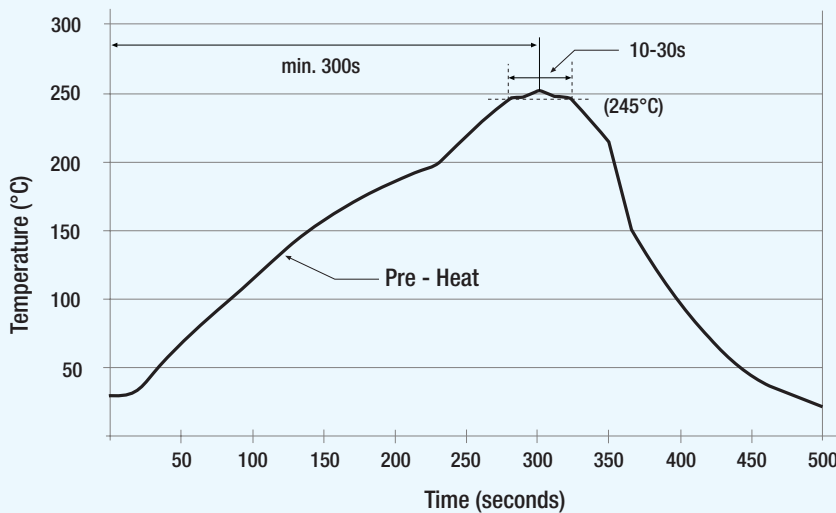

Lead-free Recommended Soldering Profile (Through hole parts)

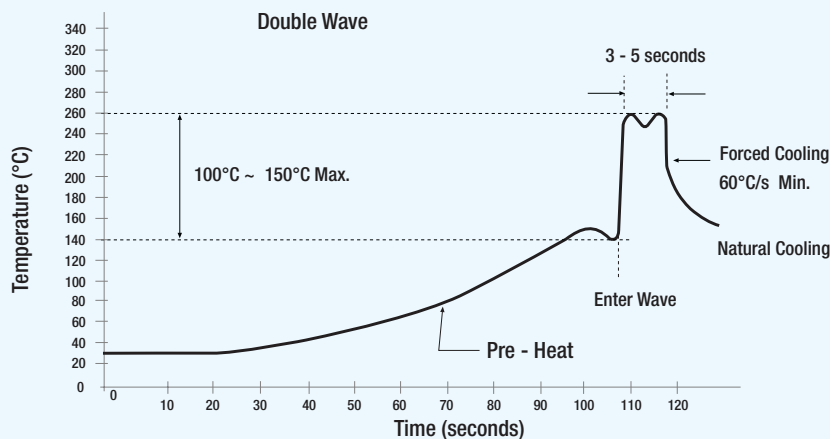

Notes: 1. The wave solder profile is measured on lead temperature.
2. Need to keep the solder parts internal temperature less than about 210°C

Solder Reflow Profile

RECOM's SMD converters are designed to withstand a maximum reflow temperature of 245°C (for max. 30seconds) in accordance with JEDEC STD-020C. If multiple reflow profiles are to be used (i.e. the part is to passthrough several reflow ovens), it is recommended that lower ramp rates be used than the maximum specified in JEDEC STD-020C. Continual thermal cycling to this profile could cause material fatigue, if more than 5 maximum ramp cycles are used.

In general these parts will exceed the re-flow capability of most IC and passive components on a PCB and should prove the most thermally insensitive component to the reflow conditions

Recommended Solder Reflow Profile:

The following 2 graphs show the typical recommended solder reflow profiles for SMD and through-hole ROHS compliant converters.

The exact values of the profile's peak and its maximum allowed duration is also given in the datasheet of each converter.

Adhesive Requirements

If SM surface mount components are going to be wave soldered (i.e. in a mixed through hole and SMD PCB) or are to be mounted on both sides of a PCB, then it is necessary to use an adhesive to fix them to the board prior to reflow.

Patterns for dispensing or printing adhesive are given for automatic lines. If dispensing manually after placement the patterns for UV cure are easily repeated using a manual syringe (even if using heat cure adhesive). If dispensing manually, dot height and size are not as important, and the adhesive should be applied after the components have been reflowed. When dispensing after reflow, a chip underfill formulation adhesive would be the preferred choice. These types 'wick' under the component body and offer a good all round adhesion from a single dispensed dot.

The patterns allow for the process spread of the stand-off on the component, but do not account for the thickness of the PCB tracks.

If thick PCB tracks are to be used, a grounded copper strip should be laid beneath the centre of the component (care should be exercised to maintain isolation barrier limits). The adhesive should not retard the pins reaching their solder pads during placement of the part, hence low viscosity adhesive is recommended.

The height of the adhesive dot, its viscosity and slumping properties are critical. The dot must be high enough to bridge the gap between board surface and component, but low enough not to slump and spread, or be squeezed by the component, and so contaminate the solder pads.

If wishing to use a greater number of dots of smaller diameter (common for pin transfer methods), the dot pattern can be changed, by following a few simple guidelines. As the number of dots is doubled their diameter should be halved and centres should be at least twice the printed diameter from each other, but the dot height should remain at 0.4mm. The printed dot should always be positioned by at least its diameter from the nearest edge of the body to the edge of the dot. The number of dots is not important, provided good contact between adhesive and body can be guaranteed, but a minimum of two dots is recommended.

Cleaning

The thermoset plastic encapsulating material used for the Recom range of surface mount DC-DC converters is not fully hermetically sealed. As with all plastic encapsulated active devices, strongly reactive agents in hostile environments can attack the material and the internal parts, hence cleaning is recommended in inert solutions (e.g. alcohol or water based

solvents) and at room temperature in an inert atmospheres (e.g. air or nitrogen).

A batch or linear aqueous cleaning process would be the preferred method of cleaning using a deionised water solution.

Vapour Phase Reflow Soldering

Vapour phase soldering is a still upcoming soldering practice; therefore there are no standard temperature profiles available. Principally, the Lead-free Soldering Profile recommended by RECOM can be used for vapour phase soldering. RECOM has tested large quantities of 8-pin and 10-pin SMD converters and recommends as an absolute maximum condition 240°C for 90s dwell time. In standard applications with small sized components on a pcb, 230°C and shorter dwell times will still deliver good results.

After discussions with various contract manufacturers, we recommended that the temperature gradients used during preheat and cooling phases are between 0.5°K/s up to 3°K/s.

Other form factors than 8-pin or 10-pin SMD-packages have not been fully tested under vapour phase conditions. Please contact RECOM in this case.

Custom DC-DC Converters

In addition to the standard ranges shown in this data book, Recom have the capability to produce custom DC-DC converters designed to your specific requirements. In general, the parts can be rapidly designed using computer based CAD tools to meet any input or output voltage requirements within the ranges of Recom standard products (i.e. up to 48V at either input or output). Prototype samples can also be produced in short timescales.

Custom parts can be designed to your specification, or where the part fits within a standard series, the generic series specification can be used. All custom parts receive the same stringent testing, inspection and quality procedures, as standard products. However there is a minimum order quantity as the additional documentation and administrative tasks must be covered in terms of costs.

A general figure for this MOQ can be around 3000pcs of low wattage converters (0,25W ~ 2W), 1000pcs medium sized wattage (2W~15W) and 500pcs for higher wattages (> 20W).

Recom custom parts are used in many applications, which are very specific to the individual customer, however, some typical examples are:

- ECL Logic driver
- Multiple cell battery configurations
- Telecommunications line equipment
- Marine apparatus
- Automotive electronics
- LCD display power circuitry
- Board level instrumentation systems

To discuss your custom DC-DC converter requirements, please contact Recom technical support desk or your local distributor.

Tin Whisker Mitigation

The use of pure tin coating has caused considerable customer concern about the possibility of tin whisker formation. Although it is the opinion of Recom that the risks of converter failure due to tin whisker formation are vanishingly small (the only actual recorded failures due to tin whiskers were in exceptional environments such as deep space or as a contributory factor to corona discharge flashover in a UHV transformer), we have undertaken tin whisker mitigation procedures as recommended by Jedec in their JP002 guidelines.

Through Hole Devices:

The pins used in all of our through-hole converters are made of hard silver-copper alloy. The pins are then nickel underplated to 0.5µm before being pure tin electroplated to 6µm thickness. This thickness of overplating is a compromise between reasonable manufacturing costs and having a thick enough coating to impair tin whisker formation. The surface is not 'brightened', also to mitigate tin whisker formation.

Finally the pins are annealed according to JIS C3101. This reduces any residual forming stresses, which is one of the other potential causes of tin whisker formation

Surface Mount Devices:

The carrier frames used in our SMD converters are made from DF42N nickel alloy which is pure tin plated. The pins are hot dipped in Sn-Ag-Cu solder just before injection molding. Hot dipping with SnAg4 or SnAgCu is generally an effective mitigation practice and considered whisker free.

Innoline Application Notes

Contents

Innoline Application Notes

- EMC Considerations
- Soft Start Circuit

• Positive-to-Negative Converters

R-78xx-0.5 Series

R-78Axx-0.5SMD Series

R-78xx-1.0 Series

R-78Axx-1.0SMD Series

R-78Bxx-1.0 Series

R-78HBxx-xx Series

R-62xxP_D Series

Pos-to-Neg Circuit Ideas

EMC Considerations

Although all Innoline converters are switching regulators, and contain internal high frequency oscillators, they have been designed to minimise radiated and conducted emissions.

If the end-application is particularly sensitive to conducted interference, the following input filter can be used for all R-78, R-5xxx, R-6xxx and R-7xxx converters.

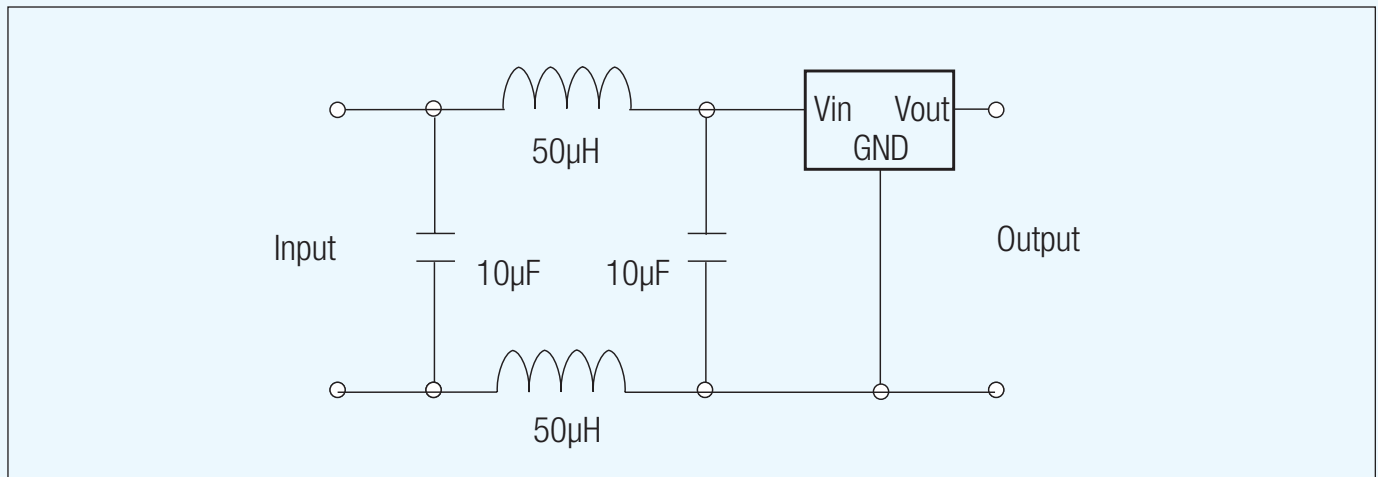

Output Soft Start

Innoline converters with Vadj pins (R-78Axx-xxSMD, R-5xxx, R-6xxx and R-7xxx families) can be fitted with an external circuit to create an output soft start. Any general purpose PNP transistor and diode can be used for TR1 and D1 and typical values for R1 = 100K and C1 = 10µF.

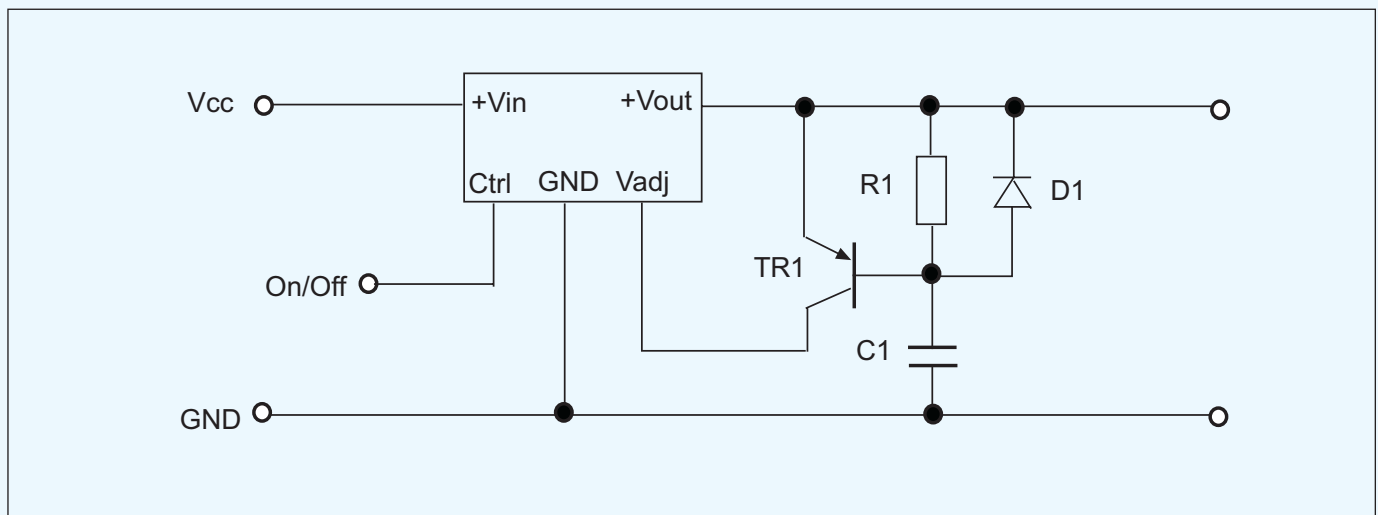

Innoline Application Notes

Positive to Negative Converters

Features

Innoline Switching Regulators

- Innoline Switching Regulators can also be used to convert a positive voltage into a negative voltage
- The standard parts can be used - only two extra capacitors are required
- Fixed and variable output voltages are available.
- Input voltage range can be lower than the output voltage for higher output voltages

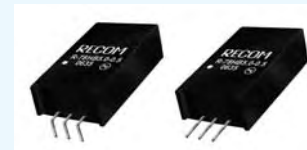
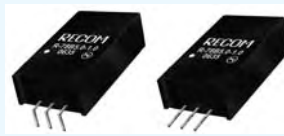

Positive-to-Negative Switching Regulators Selection Guide

Series	Maximum Output Current	Input Voltages (VDC)		Output Voltages (VDC)	No. of Outputs	Case	Adjustable Vout?	Max Cap. Load
		min.	max.					
R-78xx-0.5	-0.4A -0.2A	4.75 – 28, 5.0 – 26, 8.0 – 18		-1.5, -1.8, -2.5, -3.3, -5.0, -6.5, -9.0, -12, -15	S	SIP3	No	220µF
R-78Axx-0.5SMD	-0.4A -0.2A	4.75 – 28, 5.0 – 26, 8.0 – 18		-1.5, -1.8, -2.5, -3.3, -5.0, -6.5, -9.0, -12, -15	S	SMD	Yes	220µF
R-78xx-1.0	Not recommended to be used in this mode due to the reduced input and output voltage range							
R-78Axx-1.0SMD	Not recommended to be used in this mode due to the reduced input and output voltage range							
R-78Bxx-1.0	-0.6A -0.4A -0.3A	4.75 – 28, 8.0 – 28, 8.0 – 26 8.0 – 18		-1.5, -1.8, -2.5, -3.3, -5.0, -6.5, -9.0, -12, -15	S	SIP3	No	220µF
R-78Bxx-1.5	Not recommended to be used in this mode due to the reduced input and output voltage range							
R-78HBxx-0.5	-0.4A/-0.35A -0.3A/-0.25A/-0.2A -0.2A	15 – 65, 15 – 62, 15 – 59, 15 – 56, 20 – 48		-3.3, -5.0, -6.5 -9.0, -12, -15 -24	S	SIP3	No	100µF
R-5xxxP/DA	Not recommended to be used in this mode due to the reduced input and output voltage range							
R-61xxP/D	Not recommended to be used in this mode as R-78B series offer a lower cost alternative							
R-62xxP/D	-1A/-0.8A/-0.6A	9 - 28, 9-26		-1.8, -2.5, -3.3, -5, -9, -12	S	SIP12	Yes	470µF
R-7xxxP/D	Not recommended to be used in this mode due to the reduced efficiency and higher Ripple & Noise figures.							
Circuit Ideas								

R-78xx-0.5 Series Positive to Negative Converter

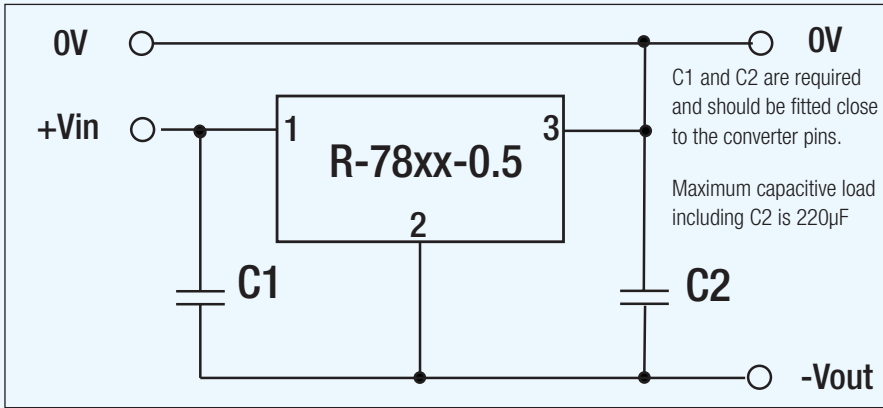

Pin Connections

Pin #	Negative Output	Positive Output
1	+Vin	+Vin
2	-Vout	GND
3	GND	+Vout

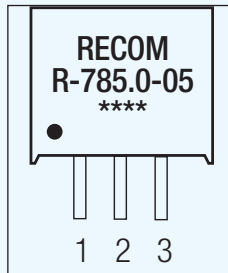

Selection Guide

Part Number SIP3	Input Range (1) (V)	Output Voltage (V)	Output Current (A)	Efficiency		External Capacitors	
				Min. Vin (%)	Max. Vin (%)	C1	C2*
R-781.5-0.5	4.75 – 28	-1.5	-0.4	68	67	10µF/35V	22µF/6.3V
R-781.8-0.5	4.75 – 28	-1.8	-0.4	71	70	10µF/50V	22µF/6.3V
R-782.5-0.5	4.75 – 28	-2.5	-0.4	75	76	10µF/50V	22µF/6.3V
R-783.3-0.5	4.75 – 28	-3.3	-0.4	77	80	10µF/50V	22µF/6.3V
R-785.0-0.5	4.75 – 28	-5.0	-0.4	79	84	10µF/50V	22µF/10V
R-786.5-0.5	5.0 – 26	-6.5	-0.3	81	86	10µF/50V	10µF/10V
R-789.0-0.5	8.0 – 18	-9.0	-0.2	87	89	10µF/50V	10µF/16V
R-7812-0.5	8.0 – 18	-12	-0.2	87	90	10µF/50V	10µF/25V
R-7815-0.5	8.0 – 18	-15	-0.2	87	91	10µF/50V	10µF/25V

* Maximum capacitive load including C2 is 220µF

Application Example (see also Circuit Ideas at end of section)

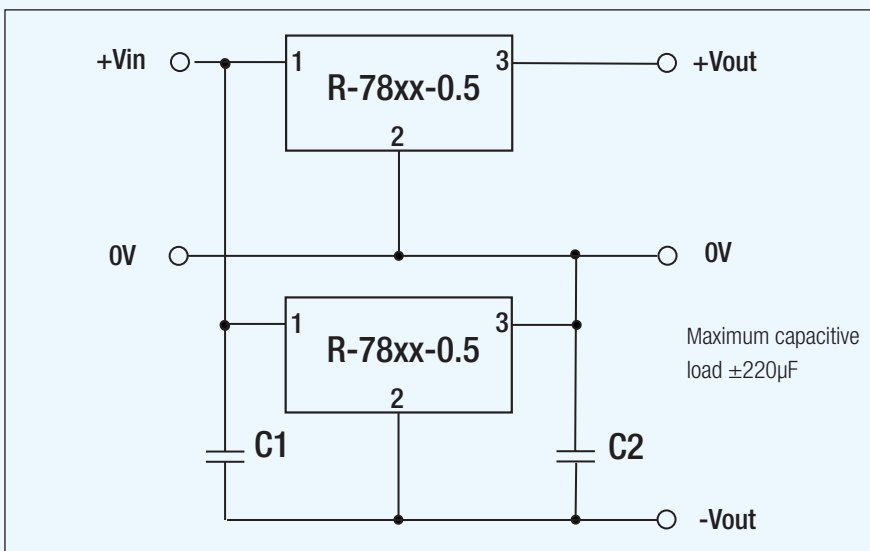

Derating-Graph (Ambient Temperature)

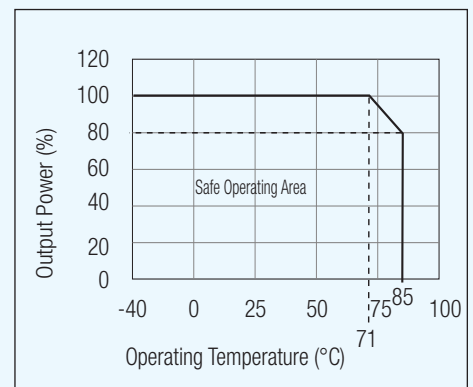

Positive to Negative Converter

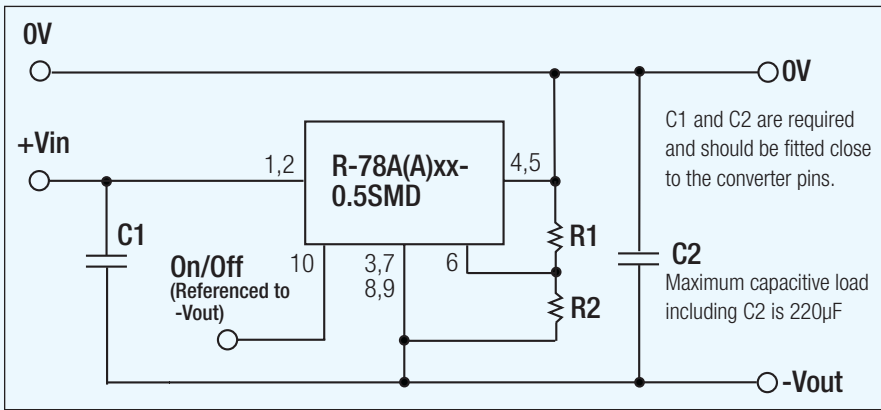

Pin Connections

Pin #	Negative Output	Positive Output
1,2	+Vin	+Vin
3,7,8,9	-Vout	GND
4,5	GND	+Vout
6	-Vout Adj.	+Vout Adj.
10	On/Off	On/Off

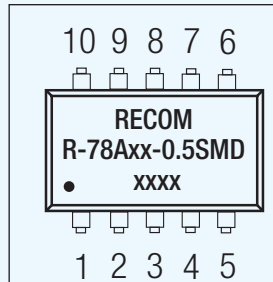

INNOLINE DC/DC-Converter

R-78A(A) xx-0.5 SMD Positive to Negative Converter

Selection Guide

Part Number SIP3	Input Range (1) (V)	Output Voltage (V)	Output Current (A)	Efficiency		External Capacitors	
				Min. Vin (%)	Max. Vin (%)	C1	C2
R-78A(A)1.5-0.5SMD	4.75 – 28	-1.5	-0.4	68	67	10 μ F/35V	22 μ F/6.3V
R-78A(A)1.8-0.5SMD	4.75 – 28	-1.8	-0.4	71	70	10 μ F/50V	22 μ F/6.3V
R-78A(A)2.5-0.5SMD	4.75 – 28	-2.5	-0.4	75	76	10 μ F/50V	22 μ F/6.3V
R-78A(A)3.3-0.5SMD	4.75 – 28	-3.3	-0.4	77	80	10 μ F/50V	22 μ F/6.3V
R-78A(A)5.0-0.5SMD	4.75 – 28	-5.0	-0.4	79	84	10 μ F/50V	22 μ F/10V
R-78A(A)6.5-0.5SMD	5.0 – 26	-6.5	-0.3	81	86	10 μ F/50V	10 μ F/10V
R-78A(A)9.0-0.5SMD	8.0 – 18	-9.0	-0.2	87	89	10 μ F/50V	10 μ F/16V
R-78A(A)12-0.5SMD	8.0 – 18	-12	-0.2	87	90	10 μ F/50V	10 μ F/25V
R-78A(A)15-0.5SMD	8.0 – 18	-15	-0.2	87	91	10 μ F/50V	10 μ F/25V

* Maximum capacitive load including C2 is 220 μ F

Application Example (see also Circuit Ideas at end of section)

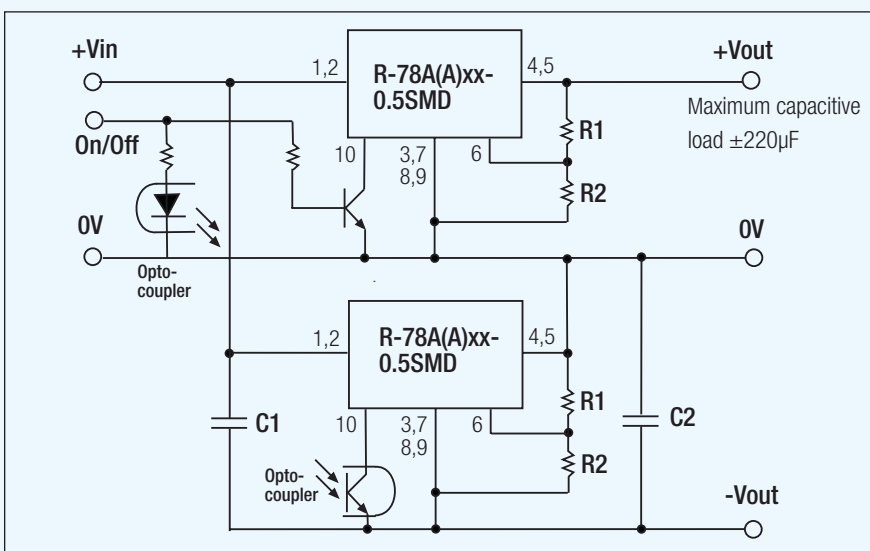

Derating-Graph (Ambient Temperature)

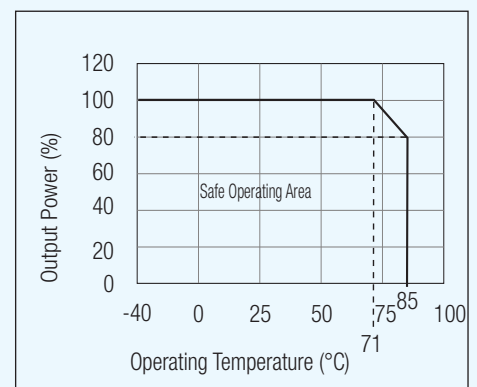

R-78A(A)xx-0.5 SMD Positive to Negative

Table 1: Adjustment Resistor Values

0.5A _{dc}	R-78A(A)1.8 -0.5SMD		R-78A(A)2.5 -0.5SMD		R-78A(A)3.3 -0.5SMD		R-78A(A)5.0 -0.5SMD		R-78A(A)6.5 -0.5SMD		R-78A(A)9.0 -0.5SMD		R-78A(A)12 -0.5SMD	
V _{out} (nom.)	1.8V _{dc}		2.5V _{dc}		3.3V _{dc}		5.0V _{dc}		6.5V _{dc}		9.0V _{dc}		12.0V _{dc}	
V _{out} (adj)	R1	R2	R1	R2	R1	R2	R1	R2	R1	R2	R1	R2	R1	R2
-1.5 (V)	3KΩ		200Ω											
-1.8 (V)			12KΩ											
-2.5 (V)		11.8KΩ												
-3.0 (V)		4.64KΩ	44.2KΩ	88.4KΩ			17KΩ							
-3.3 (V)							27KΩ	6.7KΩ						
-3.6 (V)							60.4KΩ	42KΩ	14KΩ					
-3.9 (V)							28KΩ	58KΩ	23KΩ					
-4.5 (V)							11.3kΩ	180KΩ	49KΩ	26KΩ	17KΩ			
-4.9 (V)							7.15kΩ	850KΩ	77kΩ	36KΩ	24KΩ			
-5.0 (V)							6.34kΩ		86kΩ	39KΩ	26KΩ			
-5.1 (V)							5.9kΩ	231kΩ	97KΩ	42KΩ	28KΩ			
-5.5 (V)							3.9kΩ	56.2kΩ	160KΩ	56KΩ	36KΩ			
-6.5 (V)								14kΩ		112KΩ	63KΩ			
-8.0 (V)								2.32kΩ	24.6KΩ	400KΩ	125KΩ			
-9.0 (V)									10.7KΩ		200KΩ			
-10 (V)									4.75KΩ	54.9KΩ	345KΩ			
-11 (V)									1.65KΩ	16.5KΩ	740KΩ			
-12 (V)										3.6KΩ				
-12.6 (V)										0Ω	180KΩ			

Typical Application

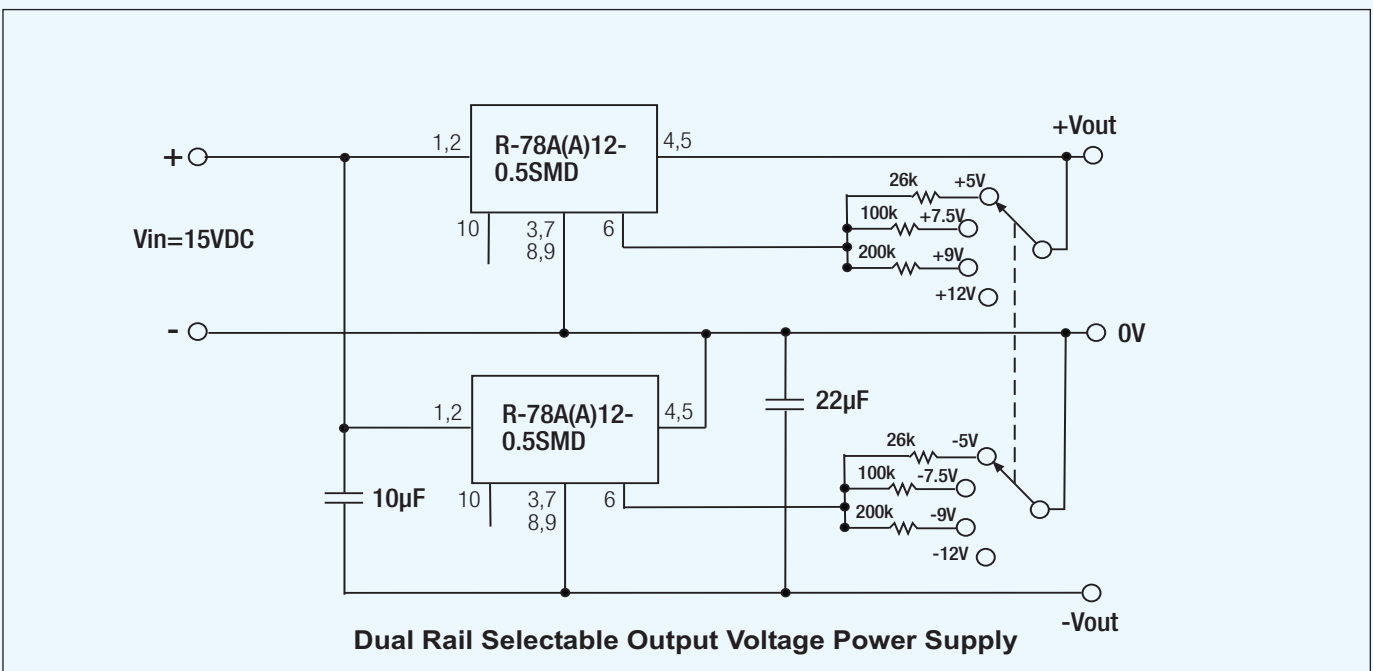

Positive to Negative Converter

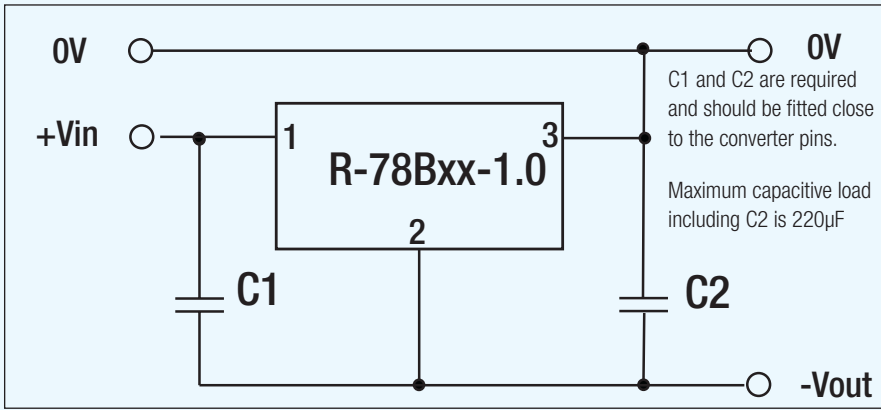

Pin Connections

Pin #	Negative Output	Positive Output
1	+Vin	+Vin
2	-Vout	GND
3	GND	+Vout

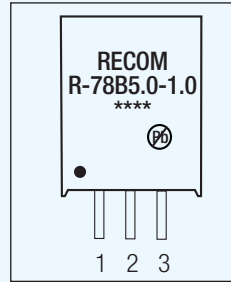

INNOLINE DC/DC-Converter

R-78Bxx- 1.0 Series Positive to Negative Converter

Selection Guide

Part Number SIP3	Input Range (1) (V)	Output Voltage (V)	Output Current (A)	Efficiency		External Capacitors	
				Min. Vin (%)	Max. Vin (%)	C1	C2*
R-78B1.5-1.0	4.75 – 28	-1.5	-0.6	70	68	10µF/50V	22µF/6.3V
R-78B1.8-1.0	4.75 – 28	-1.8	-0.6	72	72	10µF/50V	22µF/6.3V
R-78B2.5-1.0	4.75 – 28	-2.5	-0.6	75	77	10µF/50V	22µF/6.3V
R-78B3.3-1.0	4.75 – 28	-3.3	-0.6	77	80	10µF/50V	22µF/6.3V
R-78B5.0-1.0	6.5 – 28	-5.0	-0.6	83	85	10µF/50V	22µF/10V
R-78B6.5-1.0	8.0 – 26	-6.5	-0.4	84	87	10µF/50V	10µF/10V
R-78B9.0-1.0	8.0 – 18	-9.0	-0.4	88	89	10µF/25V	10µF/25V
R-78B12-1.0	8.0 – 18	-12	-0.3	89	90	10µF/25V	10µF/25V
R-78B15-1.0	8.0 – 18	-15	-0.3	89	91	10µF/25V	10µF/25V

* Maximum capacitive load including C2 is 220µF

Application Example (see also Circuit Ideas at end of section)

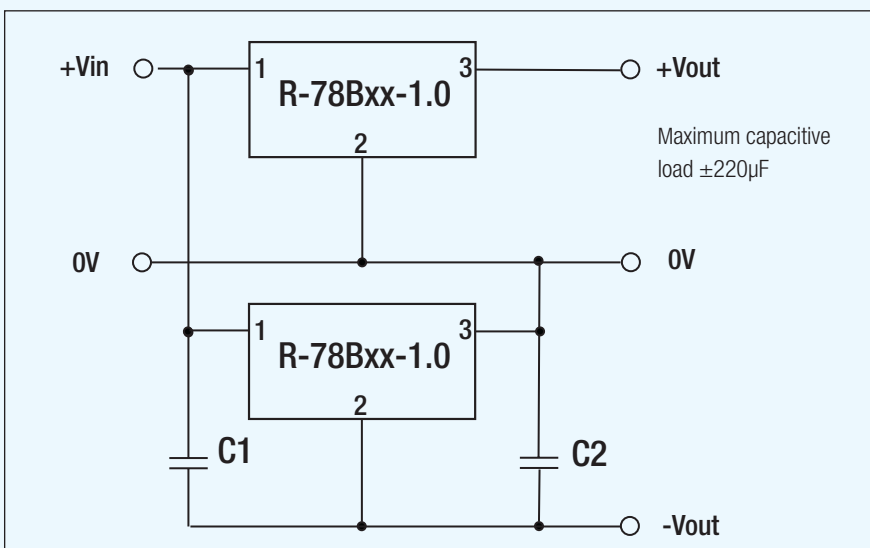

Derating-Graph (Ambient Temperature)

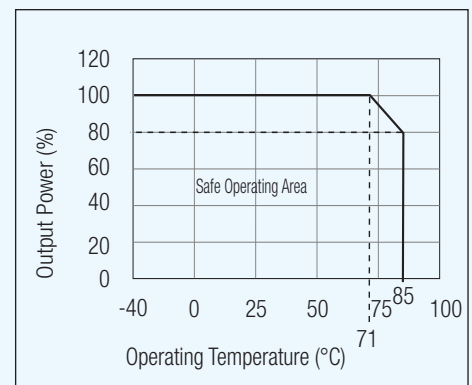

Positive to Negative Converter

INNOLINE

DC/DC-Converter

R-78HBxx-0.5 Series

Positive to Negative Converter

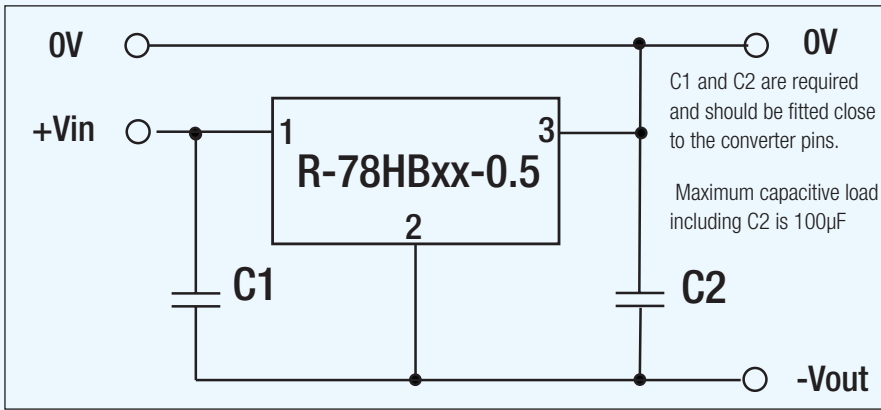

Pin Connections

Pin #	Negative Output	Positive Output
1	+Vin	+Vin
2	-Vout	GND
3	GND	+Vout

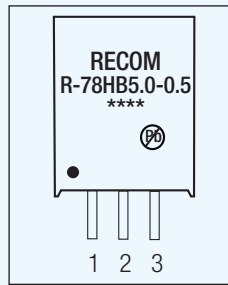

Selection Guide

Part Number SIP3	Input Range (1) (V)	Output Voltage (V)	Output Current (A)	Efficiency		External Capacitors	
				Min. Vin (%)	Max. Vin (%)	C1	C2*
R-78HB3.3-0.5	15 – 65	-3.3	-0.4	78	75	1µF/100V	22µF/6.3V
R-78HB5.0-0.5	15 – 65	-5.0	-0.4	82	80	1µF/100V	22µF/10V
R-78HB6.5-0.5	15 – 65	-6.5	-0.35	84	82	1µF/100V	22µF/10V
R-78HB9.0-0.5	15 – 62	-9.0	-0.3	87	85	1µF/100V	10µF/16V
R-78HB12-0.5	15 – 59	-12	-0.25	88	86	1µF/100V	10µF/25V
R-78HB15-0.5	15 – 56	-15	-0.2	89	87	1µF/100V	10µF/25V
R-78HB15-0.5	15 – 48	-24	-0.2	89	87	1µF/100V	10µF/35V

* Maximum capacitive load including C2 is 100µF

Application Example (see also Circuit Ideas)

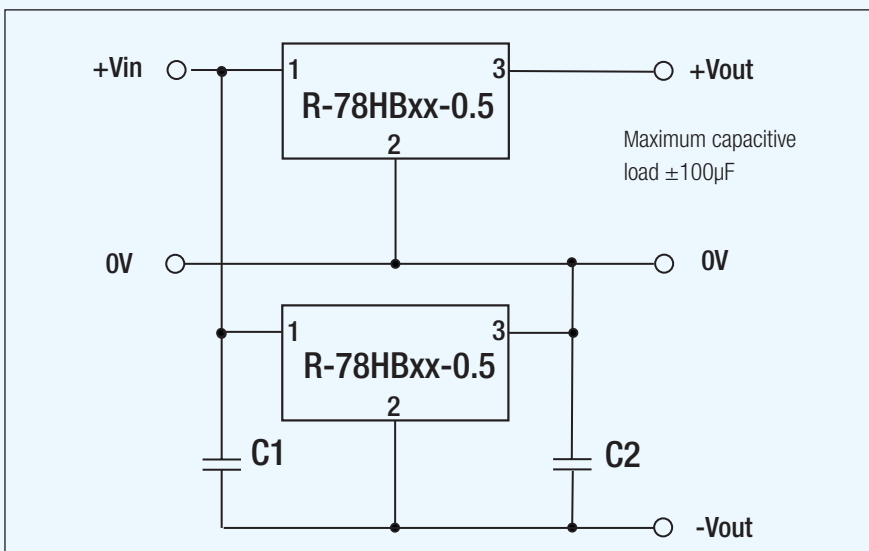

Derating-Graph (Ambient Temperature)

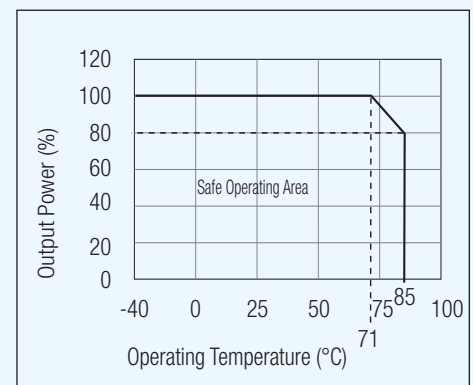

Positive to Negative Converter

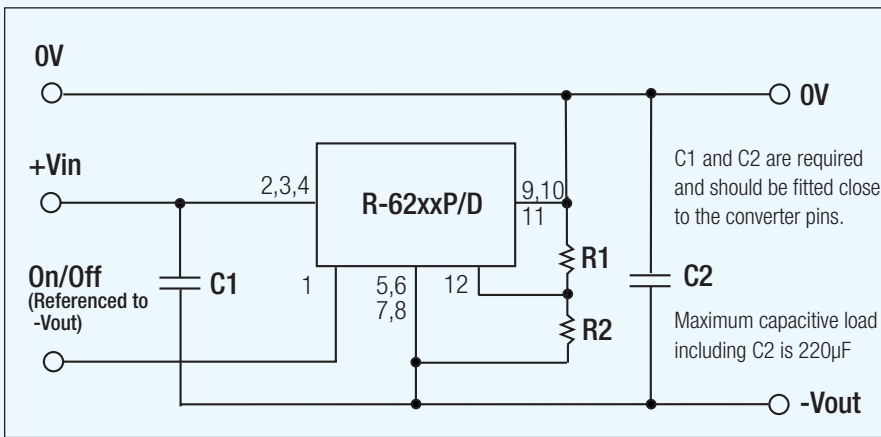

INNOLINE
DC/DC-Converter

R-62xxP/D SIP12 Positive to Negative Converter

Pin Connections

Pin #	Negative Output	Positive Output
2,3,4	+Vin	+Vin
5,6,7,8	-Vout	GND
9,10,11	GND	+Vout
12	-Vout Adj.	+Vout Adj.
1	On/Off	On/Off

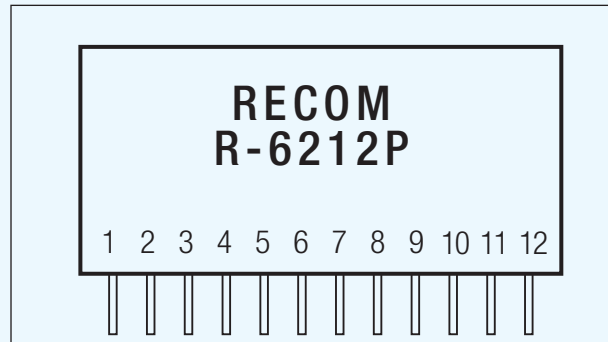

Selection Guide

Part Number SIP3	Input Range (1) (V)	Output Voltage (V)	Output Current (A)	Efficiency		External Capacitors	
				Min. Vin (%)	Max. Vin (%)	C1	C2*
R-621.8P/D	9 – 28	-1.8 (-1.5~-3.6)	-1.0	72	65	10µF/50V	100µF/6.3V
R-622.5P/D	9 – 28	-2.5 (-1.5~-4.5)	-1.0	76	72	10µF/50V	100µF/6.3V
R-623.3P/D	9 – 28	-3.3 (-1.8~-6V)	-1.0	79	76	10µF/50V	100µF/10V
R-625.0P/D	9 – 28	-5.0 (-1.8~-9V)	-1.0	81	80	10µF/50V	100µF/10V
R-629.0P/D	9 – 26	-9.0 (-3.3~-15V)	-0.8	84	85	10µF/50V	100µF/25V
R-6212P/D	9 – 26	-12 (-3.3~-15V)	-0.6	86	88	10µF/50V	100µF/25V

* Maximum capacitive load including C2 is 220µF

Derating

Max output current calculation:

Internal power dissipation
 $(1W) = I_o \times V_o \times (1 - \text{Efficiency})$
 $I_o = 1(W) / V_o \times (1 - \text{Efficiency})$

Example : R-625.0P

at $V_{in} = +9VDC$, $V_{out} = -5.0V$

Efficiency = 80% (see "Selection Guide" table)
 $I_o = 1W / 5V \times (1 - 0.8) = -1000mA$

at $V_{in} = +9VDC$, $V_{out} = -8.0V$ (with trim)

Efficiency = 80% (see "Selection Guide" table)
 $I_o = 1W / 8V \times (1 - 0.8) = -625mA$

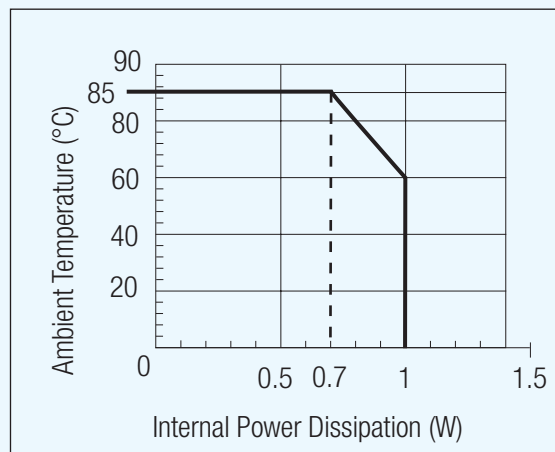

R-62xxP_D

Positive to Negative

Remote On/Off Control Application Example

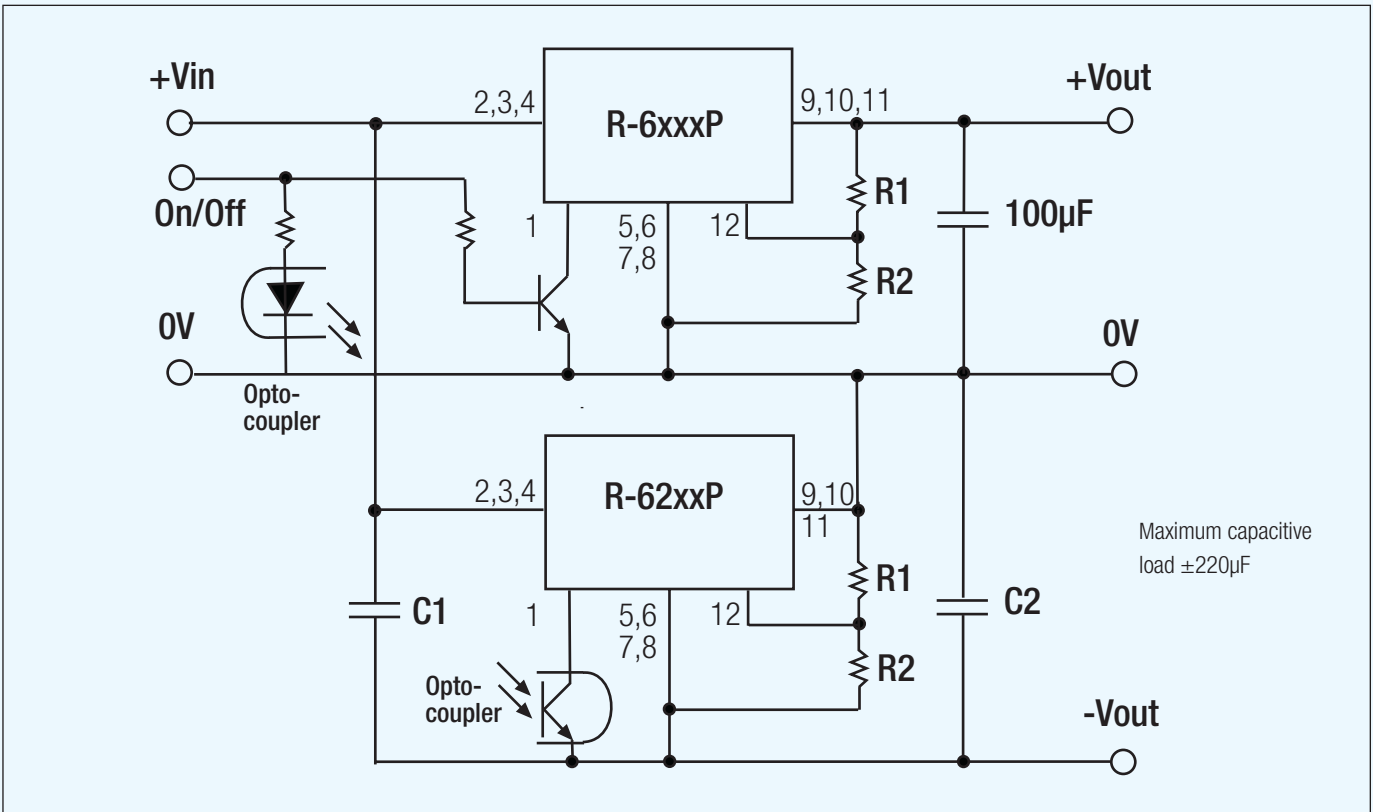
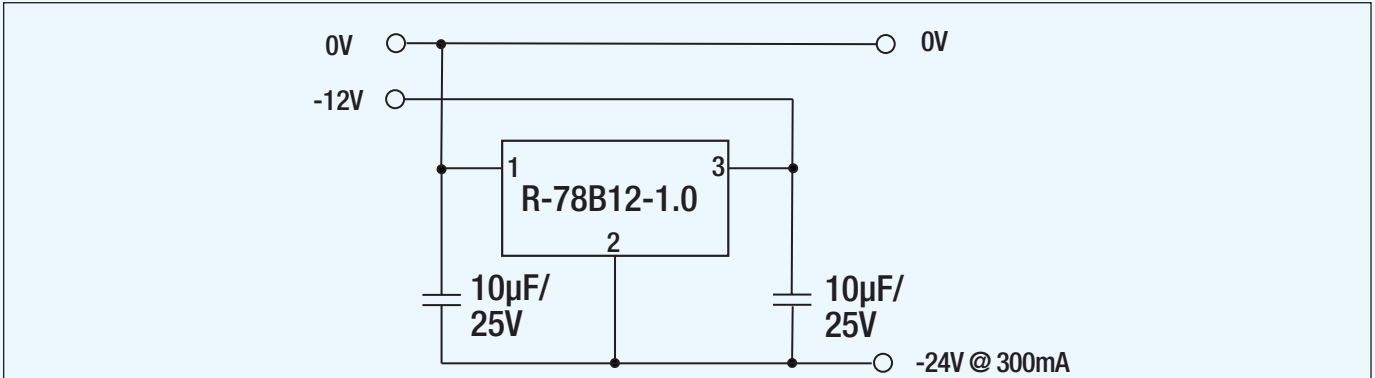

Table 1: Adjustment Resistor Values

-1A _{dc}	R-621.8P/D		R-622.5P/D		R-623.3P/D		R-625.0P/D	
V _{out} (nominal)	1.8VDC		2.5VDC		3.3VDC		5VDC	
V _{out} (adj)	R1	R2	R1	R2	R1	R2	R1	R2
1.5	13.6KΩ		3.3KΩ					
1.8			8.2KΩ		3.1KΩ		820Ω	
2.0	10KΩ		15KΩ		5.1KΩ		1.5KΩ	
2.5	5.1KΩ				13KΩ		3.6KΩ	
3.0	2.5KΩ		10KΩ		51KΩ		7.0KΩ	
3.3	1.7KΩ		5.9KΩ				9.7KΩ	
3.6	1.2KΩ		3.9KΩ		18KΩ		14KΩ	
3.9			2.8KΩ		9.1KΩ		20KΩ	
4.5			1.6KΩ		3.9KΩ		60KΩ	
5.0					2.4KΩ			
5.1					2.2KΩ		60KΩ	
5.5					1.6KΩ		15KΩ	
6.0					1.1KΩ		7.2KΩ	
7.0							2.8KΩ	
8.0							1.5KΩ	

Application Examples

Negative Voltage Doubler



12V Battery Stabilisor

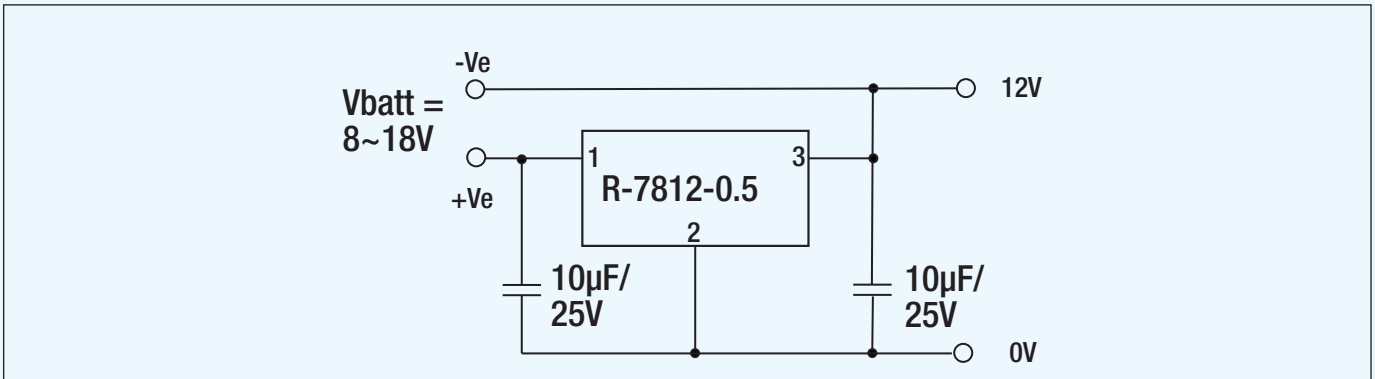

Negative Rail Generator for Asymmetric Rails

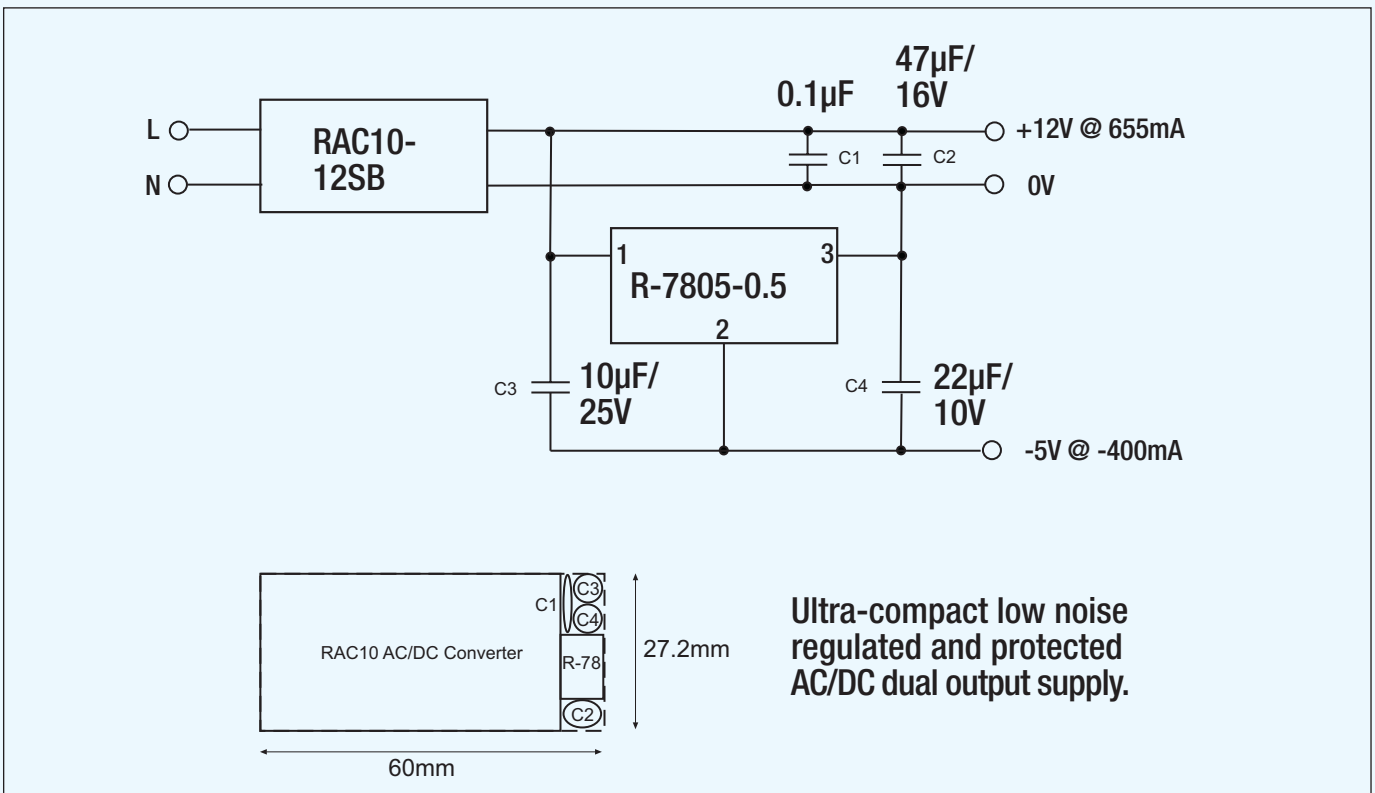

Contents

Powerline DC/DC Application Notes

- Common Mode Chokes for EMC
- Powerline Definitions and Testing

Introduction

Input Voltage Range

Pi Filter

Output Voltage Accuracy

Voltage Balance

Line Regulation

Load Regulation

Efficiency

Switching Frequency

Output Ripple and Noise

Transient Recovery Time

Current Limiting

Fold Back Current Limiting

Isolation

Break Down Voltage

Temperature Coefficient

Ambient Temperature

Operating Temperature Range

Storage Temperature Range

- Undervoltage Lockout Tables

- Output Voltage Trim Tables

- Powerline Heat Sinks

Heat Sink Dimensions

Powerline AC/DC Application Notes

Input Fuse

Earthing

Combining Converters

DC Inputs

Common Mode Chokes for EMC

Recom offers a range of Common Mode Chokes useful for EMI Filtering to meet the requirements of EN-55022, Class B. The component values given are suggested values and may need to be optimised to suit the application. The effectiveness of any filter network is heavily dependent on using quality capacitors, the layout of the board and having a low impedance path to ground. See section on filtering elsewhere in the Application Notes for more details.

Class B EMC Filter Suggestion

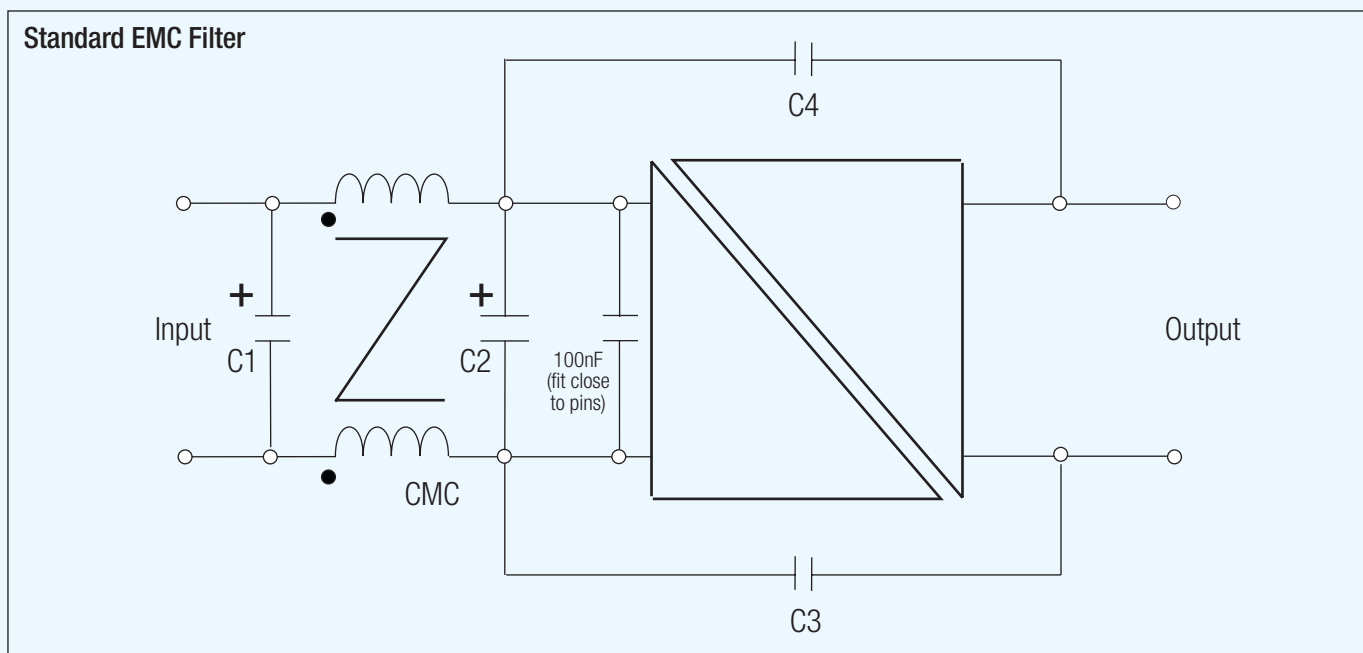

RP15-SO_D0 and RP15-SOW_D0W Series Only

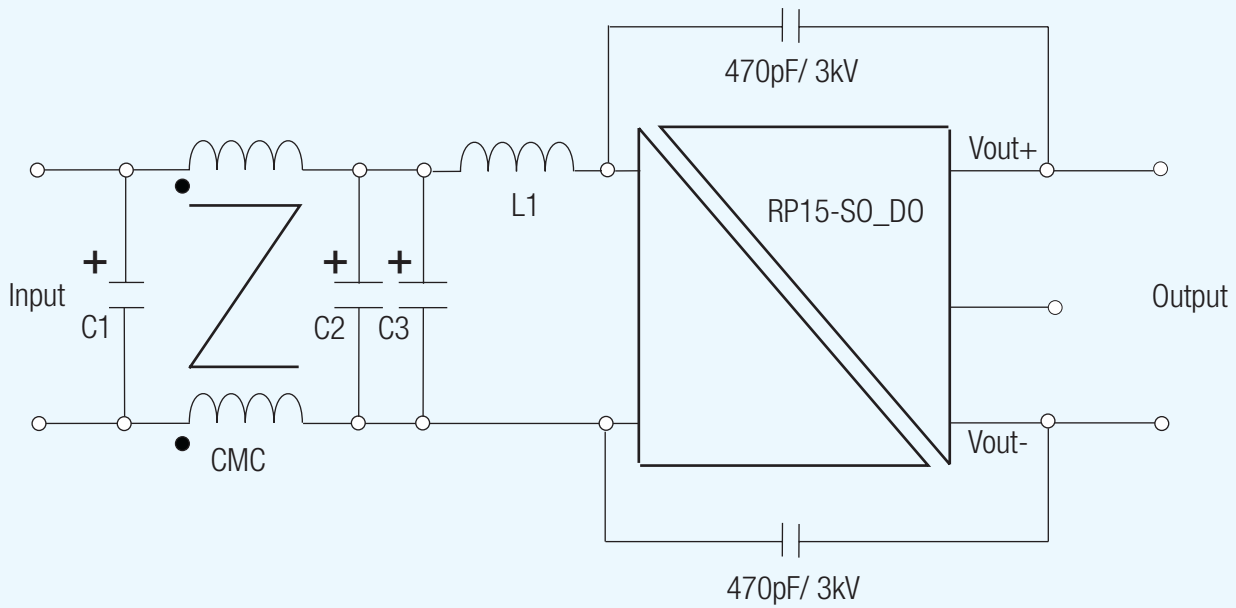

RP30-SF_DF and RP30-SF W_DFW Series Only

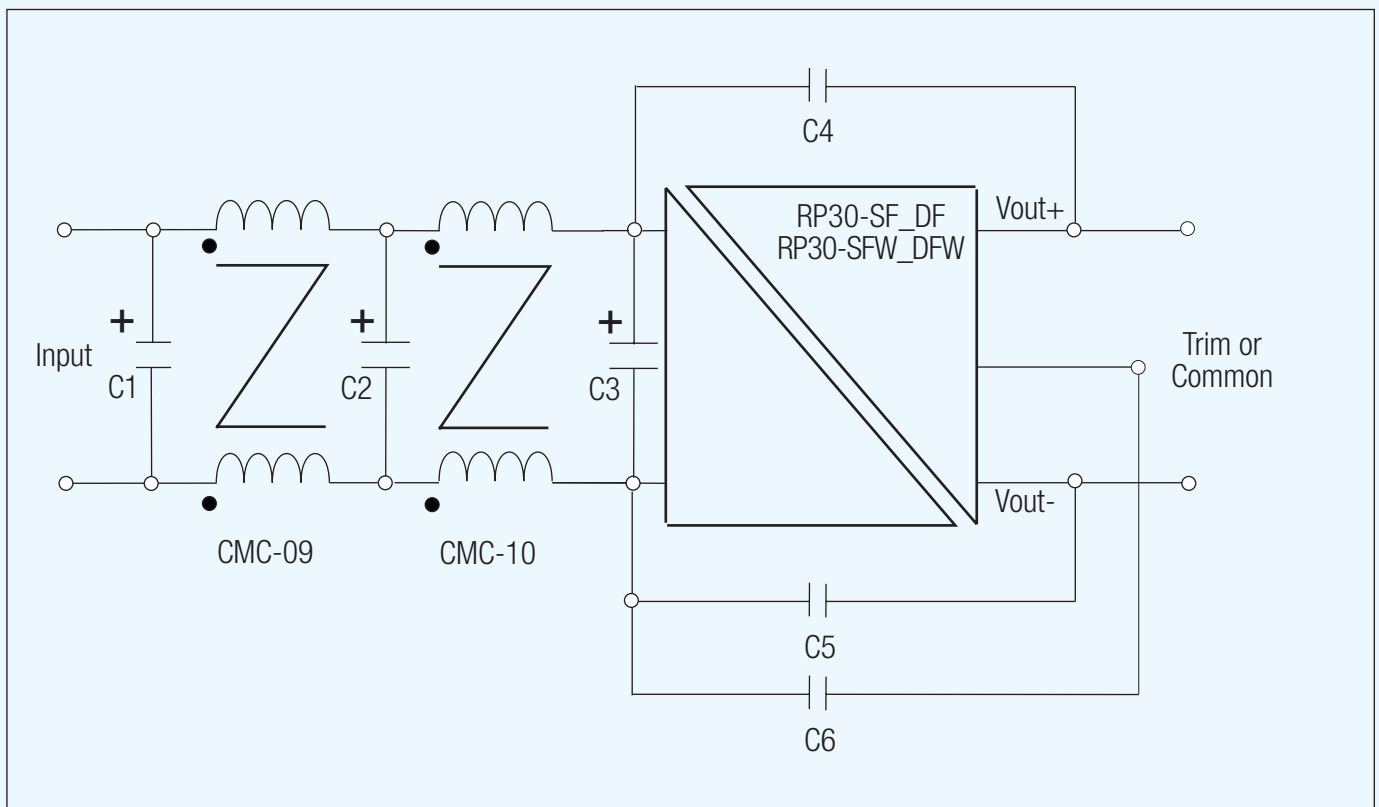

Component Values

All capacitors MLCC (Multi Layer Ceramic Capacitor).

RP08-A	Vin = 12VDC nom., C1=4.7μF/50V, C2=Not Required, C3,C4=1nF/3kV, CMC-06 Vin = 24VDC nom., C1=6.8μF/50V, C2=Not Required, C3,C4=1nF/3kV, CMC-06 Vin = 48VDC nom., C1=2.2μF/100V, C2=2.2μF/100V, C3,C4=1nF/3kV, CMC-06
RP08-AW	Vin = 9~36VDC, C1=4.7μF/50V, C2=Not Required, C3,C4=1nF/3kV, CMC-06 Vin = 18~75VDC, C1=2.2μF/100V, C2=2.2μF/100V, C3,C4=1nF/3kV, CMC-06
RP10-E RP12-A	Vin = 12VDC nom., C1=3.3μF/50V, C2=Not Required, C3,C4=1nF/2kV, CMC-06 Vin = 24VDC nom., C1=4.7μF/50V, C2=Not Required, C3,C4=1nF/2kV, CMC-06 Vin = 48VDC nom., C1=2.2μF/100V, C2=2.2μF/100V, C3,C4=1nF/2kV, CMC-06
RP10-EW RP12-AW	Vin = 9~36VDC, C1=3.3μF/50V, C2=Not Required, C3,C4=1nF/2kV, CMC-06 Vin = 18~75VDC, C1=2.2μF/100V, C2=2.2μF/100V, C3,C4=1nF/2kV, CMC-07
RP15-A	Vin = 12VDC nom., C1=10μF/25V, C2=10μF/25V, C3,C4=470pF/2kV, CMC-07 Vin = 24VDC nom., C1=6.8μF/50V, C2=6.8μF/50V, C3,C4=470pF/2kV, CMC-06 Vin = 48VDC nom., C1=2.2μF/100V, C2=2.2μF/100V, C3,C4=470pF/2kV, CMC-01
RP15-AW	Vin = 9~36VDC, C1=6.8μF/50V, C2=6.8μF/50V, C3,C4=470pF/2kV, CMC-05 Vin = 18~75VDC, C1=2.2μF/100V, C2=2.2μF/100V, C3,C4=470pF/2kV, CMC-06
RP15-0	Vin = 12VDC nom., C1=10μF/25V, C2=10μF/25V, L1 = 10μH, , CMC-07 Vin = 24VDC nom., C1=6.8μF/50V, C2=6.8μF/50V, L1 = 10μH, , CMC-07 Vin = 48VDC nom., C1=2.2μF/100V, C2=2.2μF/100V, L1 = 18μH, CMC-07
RP15-0W	Vin = 9~36VDC, C1, C2, C3 =6.8μF/50V, CMC-07 Vin = 18~75VDC, C1=2 x 2.2μF/100V in parallel, C2,C3 =2.2μF/100V, L1 = 33μH, CMC-06
RP15-F	Vin = 12VDC nom., C1=4.7μF/50V, C2=Not Required, C3,C4=1nF/2kV, CMC-06 Vin = 24VDC nom., C1=3.3μF/50V, C2=Not Required, C3,C4=1nF/2kV, CMC-06 Vin = 48VDC nom., C1=2.2μF/100V, C2=2.2μF/100V, C3,C4=1nF/2kV, CMC-06
RP15-FW	Vin = 9~36VDC, C1=2.2μF/50V, C2=Not Required, C3,C4=1nF/2kV, CMC-05 Vin = 18~75VDC, C1=2.2μF/100V, C2=2.2μF/100V, C3,C4=1nF/2kV, CMC-06
RP20-F	Vin = 12VDC nom., C1=4.7μF/50V, C2=Not Required, C3,C4=1nF/2kV, CMC-05 Vin = 24VDC nom., C1=4.7μF/50V, C2=Not Required, C3,C4=1nF/2kV, CMC-05 Vin = 48VDC nom., C1=2.2μF/100V, C2=2.2μF/100V, C3,C4=1nF/2kV, CMC-05
RP20-FW	Vin = 9~36VDC, C1=4.7μF/50V, C2=Not Required, C3,C4=1nF/2kV, CMC-05 Vin = 18~75VDC, C1=2.2μF/100V, C2=2.2μF/100V, C3,C4=1nF/2kV, CMC-06
RP30-E	Vin = 12VDC nom., C1=4.7μF/25V, C2=Not Required, C3,C4=1nF/2kV, CMC-05 Vin = 24VDC nom., C1=6.8μF/50V, C2=6.8μF/50V, C3,C4=1nF/2kV, CMC-05 Vin = 48VDC nom., C1=2.2μF II 2.2μF/100V, C2=2.2μF II 2.2μF/100V, C3,C4=1nF/2kV, CMC-05
RP30-EW	Vin = 9~36VDC, C1=6.8μF/50V, C2=6.8μF/50V, C3,C4=1nF/2kV, CMC-05 Vin = 18~75VDC, C1=2.2μF II 2.2μF/100V, C2=2.2μF II 2.2μF/100V, C3,C4=1nF/2kV, CMC-05

Continued on next page

RP30-F	$V_{in} = 12\text{VDC nom.}, C1, C2, C3 = 10\mu\text{F}/25\text{V}, C4, C5, C6 = 1\text{nF}/2\text{kV}, \text{CMC1} = \text{CMC-09}, \text{CMC2} = \text{CMC-10}$
	$V_{in} = 24\text{VDC nom.}, C1, C2, C3 = 4.7\mu\text{F}/50\text{V}, C4, C5, C6 = 1\text{nF}/2\text{kV}, \text{CMC1} = \text{CMC-09}, \text{CMC2} = \text{CMC-10}$
	$V_{in} = 48\text{VDC nom.}, C1, C2, C3 = 2.2\mu\text{F}/100\text{V}, C4, C5, C6 = 1\text{nF}/2\text{kV}, \text{CMC1} = \text{CMC-09}, \text{CMC2} = \text{CMC-10}$
RP30-FW	$V_{in} = 9\sim 36\text{VDC}, C1, C2, C3 = 4.7\mu\text{F}/50\text{V}, C4, C5, C6 = 1\text{nF}/2\text{kV}, \text{CMC1} = \text{CMC-09}, \text{CMC2} = \text{CMC-10}$
	$V_{in} = 18\sim 75\text{VDC}, C1, C2, C3 = 4.7\mu\text{F}/50\text{V}, C4, C5, C6 = 1\text{nF}/2\text{kV}, \text{CMC1} = \text{CMC-09}, \text{CMC2} = \text{CMC-10}$
RP40-G	$V_{in} = 12\text{VDC nom.}, C1 = 4.7\mu\text{F}/50\text{V}, C2 = \text{Not Required}, C3, C4 = 1\text{nF}/2\text{kV}, \text{CMC-05}$
	$V_{in} = 24\text{VDC nom.}, C1 = 6.8\mu\text{F}/50\text{V}, C2 = 6.8\mu\text{F}/50\text{V}, C3, C4 = 1\text{nF}/2\text{kV}, \text{CMC-05}$
	$V_{in} = 48\text{VDC nom.}, C1 = 2.2\mu\text{F} \parallel 2.2\mu\text{F}/100\text{V}, C2 = 2.2\mu\text{F} \parallel 2.2\mu\text{F}/100\text{V}, C3, C4 = 1\text{nF}/2\text{kV}, \text{CMC-08}$
RP40-GW	$V_{in} = 9\sim 36\text{VDC}, C1 = 4.7\mu\text{F}/50\text{V}, C2 = 4.7\mu\text{F}/50\text{V}, C3, C4 = 1\text{nF}/2\text{kV}, \text{CMC-05}$
	$V_{in} = 18\sim 75\text{VDC}, C1 = 2.2\mu\text{F} \parallel 2.2\mu\text{F}/100\text{V}, C2 = 2.2\mu\text{F} \parallel 2.2\mu\text{F}/100\text{V}, C3, C4 = 1\text{nF}/2\text{kV}, \text{CMC-08}$
RP60-G	$V_{in} = 24\text{VDC nom.}, C1 = 4.7\mu\text{F}/50\text{V}, C2 = 4.7\mu\text{F}/50\text{V}, C3, C4 = 1\text{nF}/2\text{kV}, \text{CMC-05}$
	$V_{in} = 48\text{VDC nom.}, C1 = 2.2\mu\text{F} \parallel 2.2\mu\text{F}/100\text{V}, C2 = 2.2\mu\text{F} \parallel 2.2\mu\text{F}/100\text{V}, C3, C4 = 1\text{nF}/2\text{kV}, \text{CMC-08}$

Recommended PCB Layouts

Standard EMC Filter

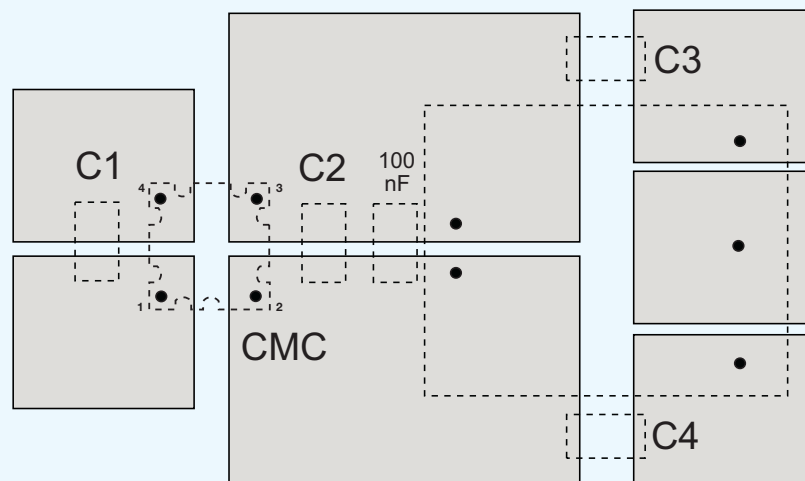

RP15-0 Open Frame Converters

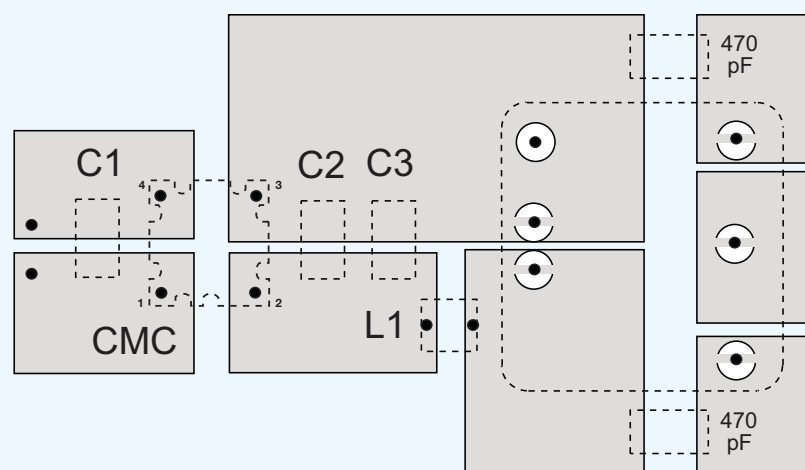

Recommended PCB Layouts

RP30-S_DF
RP30-S_DFW

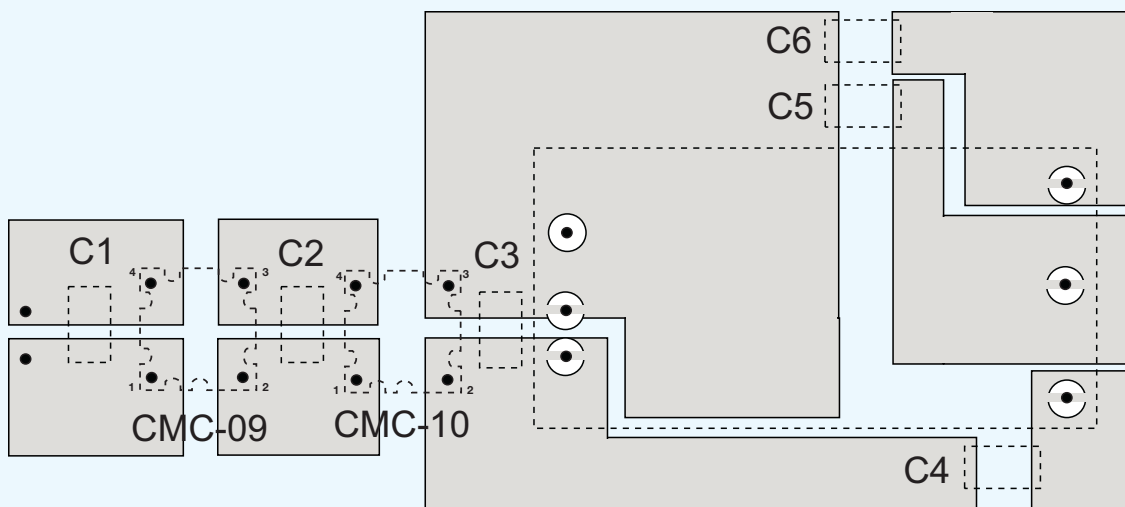

General Information about Recom Common Mode Chokes

Recom common mode chokes are all RoHS conform.

Maximum Rated Voltage = 500VDC

Operating Temperature = -40°C ~ +105°C

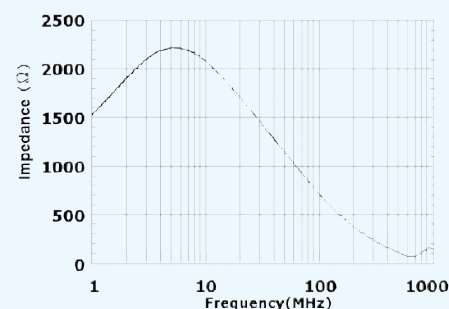

Typical Impedance curve (CMC-08)

Recommended Footprint Details

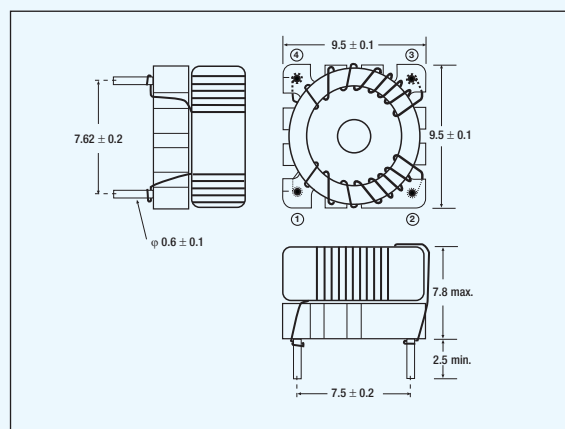
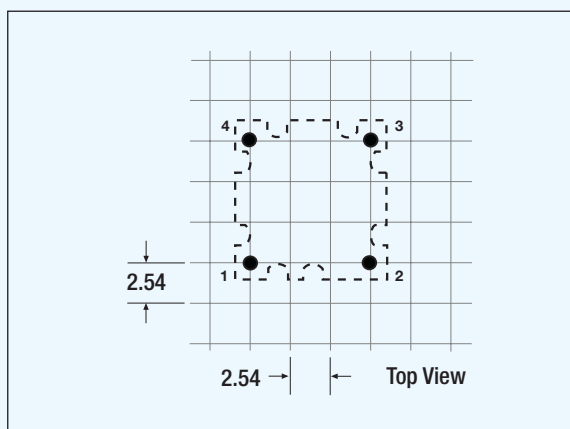

CMC-01

Component	Inductance	Rating	DCR
CMC-01	620μHx2	1.7A	80mΩ

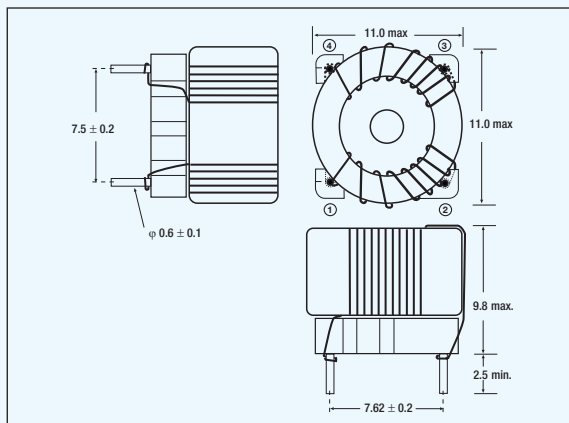

CMC-05

Component	Inductance	Rating	DCR
CMC-05	450 μ Hx2	5.2A	25mOhm

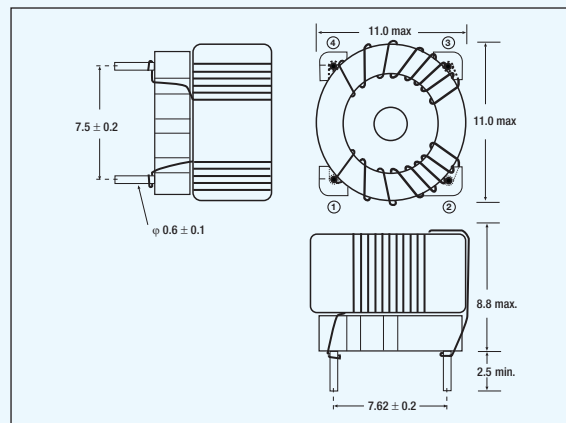

CMC-06

Component	Inductance	Rating	DCR
CMC-06	325 μ Hx2	3.3A	35mOhm

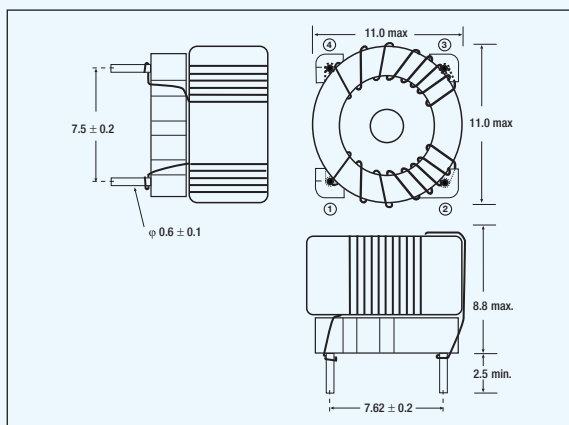

CMC-07

Component	Inductance	Rating	DCR
CMC-7	145 μ Hx2	5.2A	20mOhm

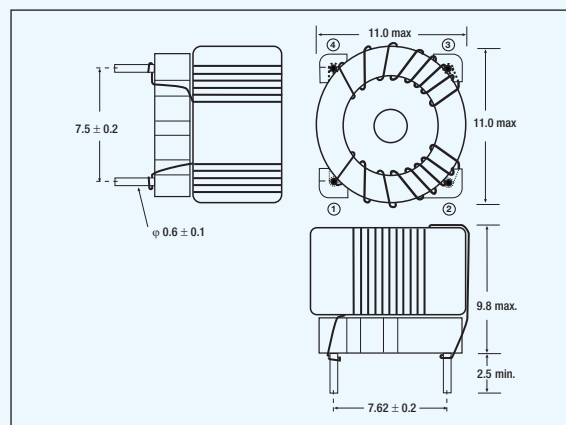

CMC-08

Component	Inductance	Rating	DCR
CMC-8	830 μ Hx2	5.2A	31mOhm

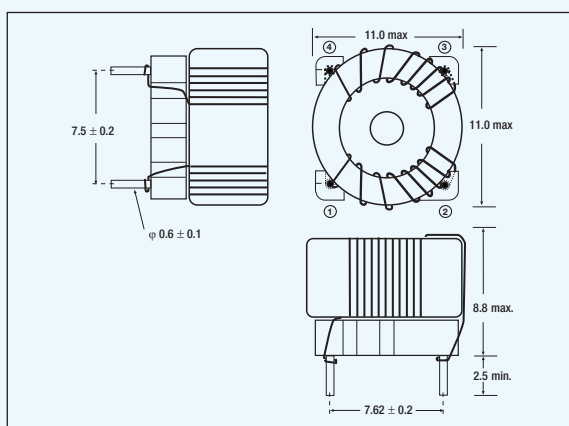

CMC-09

Component	Inductance	Rating	DCR
CMC-7	33,3 μ Hx2	3.3A	10mOhm

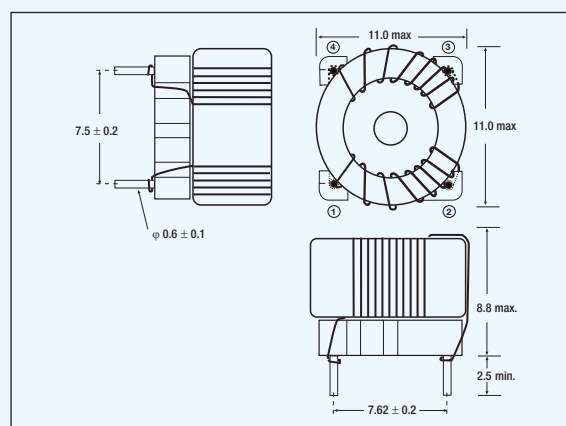

CMC-10

Component	Inductance	Rating	DCR
CMC-10	55 μ Hx2	4A	7mOhm

Definitions and Testing

General Test Set-Up

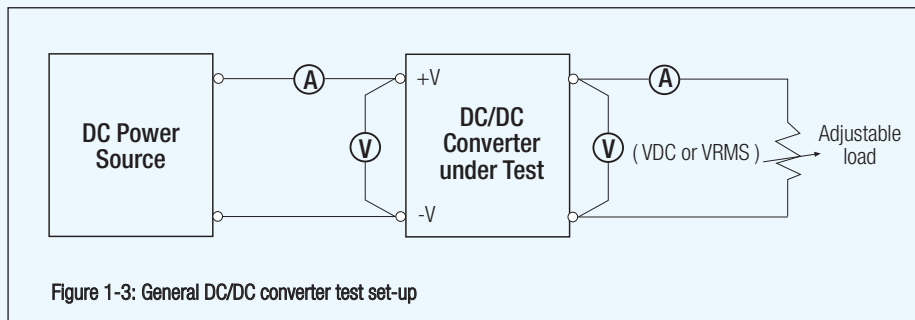

Figure 1-3: General DC/DC converter test set-up

Note: If the converter is under test with remote sense pins, connect these pins to their respective output pins. All tests are made in "Local sensing" mode.

Input Voltage Range

The minimum and maximum input voltage limits within which a converter will operate to specifications.

PI Filter

An input filter, consisting of two capacitors, connected before and after a series inductor to reduce input reflected ripple current. The effective filter is $C1/L + L/C2$, so the inductor filter element is doubly effective.

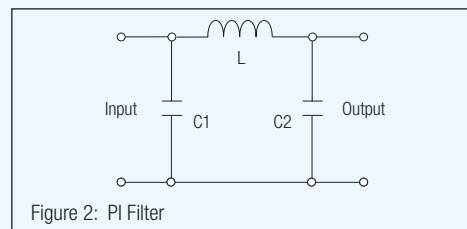

Figure 2: PI Filter

Output Voltage Accuracy

With nominal input voltage and rated output load from the test set-up, the DC output voltage is measured with an accurate, calibrated DC voltmeter. Output voltage accuracy is the difference between the measured output voltage and specified nominal value as a percentage. Output accuracy (as a %) is then derived by the formula:

$$\frac{V_{out} - V_{nom}}{V_{nom}} \times 100$$

V_{nom} is the nominal output specified in the converter data sheet.

Voltage Balance

For a multiple output power converter, the percentage difference in the voltage level of two outputs with opposite polarities and equal nominal values.

Line Regulations

Make and record the following measurements with rated output load at +25°C:

- Output voltage at nominal line (input) voltage. $V_{out N}$
- Output voltage at high line (input) voltage. $V_{out H}$
- Output voltage at low line (input) voltage. $V_{out L}$

The line regulation is $V_{out M}$ (the maximum of the two deviations of output) for the value at nominal input in percentage.

$$\frac{V_{out M} - V_{out N}}{V_{out N}} \times 100$$

Definitions and Testing

Load Regulation

Make and record the following measurements with rated output load at +25°C:

- Output voltage with rated load connected to the output. ($V_{out FL}$)
- Output voltage with no load or the minimum specified load for the DC-DC converter. ($V_{out ML}$)

Load regulation is the difference between the two measured output voltages as a percentage of output voltage at rated load.

$$\frac{V_{out ML} - V_{out FL}}{V_{out FL}} \times 100$$

Efficiency

The ratio of output load power consumption to input power consumption expressed as a percentage. Normally measured

at full rated output power and nominal line conditions.

Switching Frequency

The rate at which the DC voltage is switched in a DC-DC converter or switching power supply. The ripple frequency is

double the switching frequency in push-pull designs.

Output Ripple and Noise

Because of the high frequency content of the ripple, special measurement techniques must be employed so that correct measurements are obtained. A 20MHz bandwidth oscilloscope is used, so that all significant harmonics of the ripple spike are included.

This noise pickup is eliminated as shown in Figure 3, by using a scope probe with

an external connection ground or ring and pressing this directly against the output common terminal of the power converter, while the tip contacts the voltage output terminal. This provides the shortest possible connection across the output terminals.

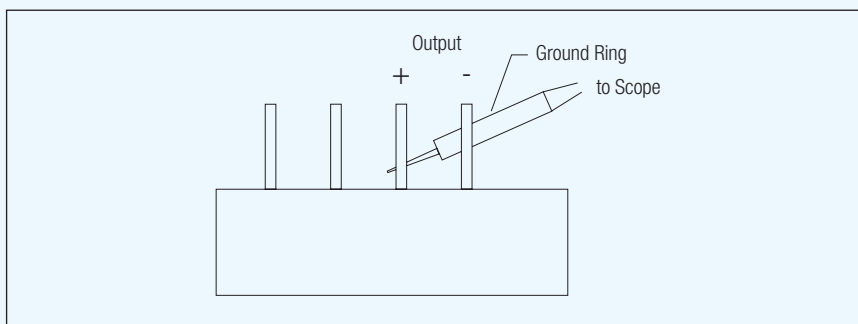

Figure 3:

Definitions and Testing

Output Ripple and Noise (continued)

Figure 4 shows a complex ripple voltage waveform that may be present on the output of a switching power supply. There are three components in the waveform, first is a charging component that originates from the output rectifier and filter, then there is the discharging component due to the load discharging the output capacitor between cycles, and finally there are small high frequency switching spikes imposed on the low frequency ripple.

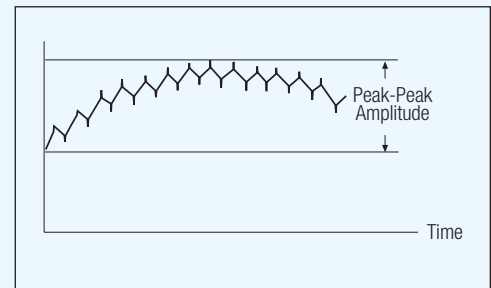
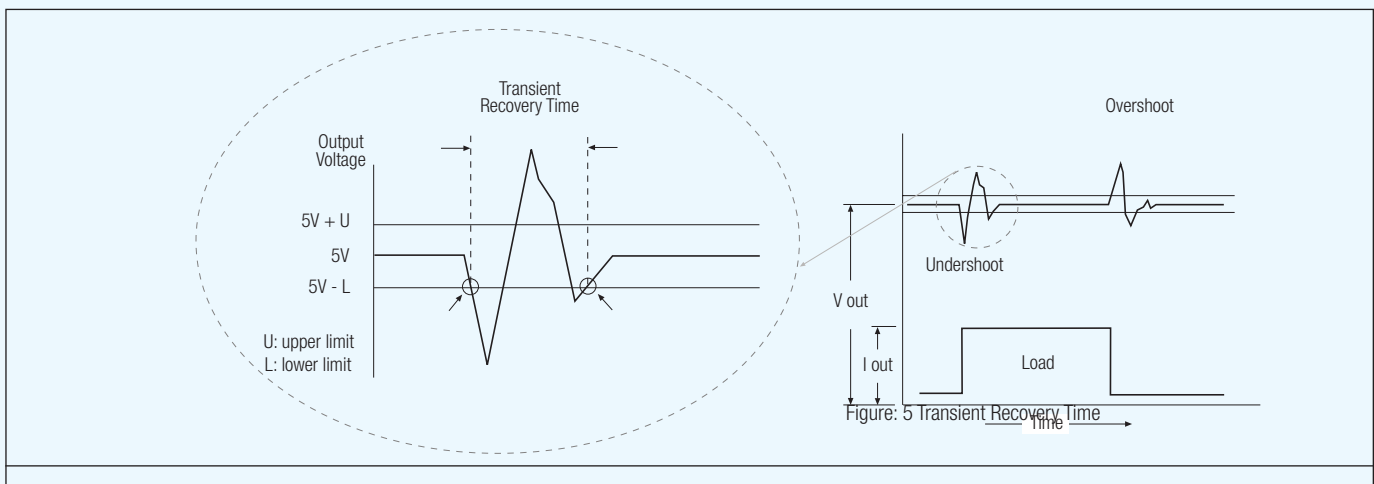

Figure 4: Amplitude

Transient Recovery Time

The time required for the power supply output voltage to return to within a specified percentage of rated value, following a step change in load current.



Current Limiting

output current is limited to prevent damage of the converter at overload situations. If the output is shorted, the

output voltage is regulated down so the current from the outputs cannot be excessive.

Fold Back Current Limiting

A method of protecting a power supply from damage in an overload condition, reducing the output current as the load approaches short circuit.

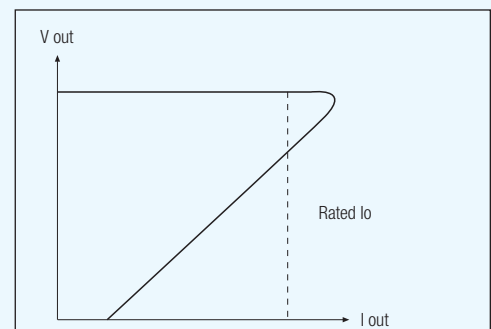

Figure 6: Fold Back Current LimitingTime

Definitions and Testing

Isolation

The electrical separation between the input and output of a converter, (consisting of resistive and capacitive isolation)

normally determined by transformer-characteristics and circuit spacing.

Break-Down Voltage

The maximum continuous DC voltage, which may be applied between the input and output terminal of a power supply without causing damage.

Typical break-down voltage for DC-DC converters is 1600VDC because the equivalent DC isolation for 230VAC continuous rated working voltage is 1500VDC.

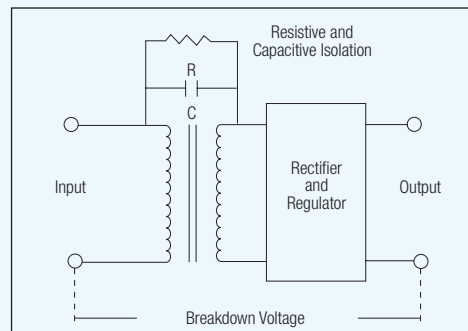

Figure 7:

Temperature Coefficient

With the power converter in a temperature test chamber at full rated output load, make the following measurements:

- Output voltage at +25°C ambient temperature.
- Set the chamber for maximum operating ambient temperature and allow the power converter to stabilize for 15 to 30 minutes. Measure the output voltage.
- Set the chamber to minimum operating ambient temperature and allow the power converter to stabilize for 15 to 30 minutes.

- Divide each percentage voltage deviation from the +25°C ambient value by the corresponding temperature change from +25°C ambient.

The temperature coefficient is the higher one of the two values calculated above, expressed as percent per change centigrade.

Ambient Temperature

The temperature of the still-air immediately surrounding an operating power supply. Care should be taken when comparing manufacturer's data-

sheets that still-air ambient temperature and not case temperature is quoted.

Operating Temperature Range

The range of ambient or case temperature within a power supply at which

it operates safely and meets its specifications.

Storage Temperature Range

The range of ambient temperatures within a power supply at non-opera-

ting condition, with no degradation in its subsequent operation.

Trim Tables

Output Voltage Trimming:

Some converters from our Powerline offer the feature of trimming the output voltage in a certain range around the nominal value by using external trim resistors. Because different series use different circuits for trimming, no general equation can be given for calculating the trim resistors.

The following trimtables give values for choosing these trimming resistors. If voltages between the given trim points are required, extrapolate between the two nearest given values to work out the resistor required or use a variable resistor to set the voltage.

Single Output Voltage Trim Tables

RP15-, RP20-, RP30-, RP40-, RP60- xx3.3S

(For RP15-SA/SAW and RP15-SO/SOW see next page)

Trim up	1	2	3	4	5	6	7	8	9	10	%
V _{out} =	3,333	3,366	3,399	3,432	3,465	3,498	3,531	3,564	3,597	3,63	Volts
R _U =	57.93	26.16	15.58	10.28	7.11	4.99	3.48	2.34	1.46	0.75	KOhms
Trim down	1	2	3	4	5	6	7	8	9	10	%
V _{out} =	3,267	3,234	3,201	3,168	3,135	3,102	3,069	3,036	3,003	2,97	Volts
R _D =	69.47	31.23	18.49	12.12	8.29	5.74	3.92	2.56	1.50	0.65	KOhms

RP15-, RP20-, RP30-, RP40-, RP60- xx05S

(For RP15-SA/SAW and RP15-SO/SOW see next page)

Trim up	1	2	3	4	5	6	7	8	9	10	%
V _{out} =	5,05	5,1	5,15	5,2	5,25	5,3	5,35	5,4	5,45	5,5	Volts
R _U =	36.57	16.58	9.92	6.58	4.59	3.25	2.30	1.59	1.03	0.59	KOhms
Trim down	1	2	3	4	5	6	7	8	9	10	%
V _{out} =	4,95	4,9	4,85	4,8	4,75	4,7	4,65	4,6	4,55	4,5	Volts
R _D =	45.53	20.61	12.31	8.15	5.66	4.00	2.81	1.92	1.23	0.68	KOhms

RP15-, RP20-, RP30-, RP40-, RP60-xx12S

(For RP15-SA/SAW and RP15-SO/SOW see next page)

Trim up	1	2	3	4	5	6	7	8	9	10	%
V _{out} =	12,12	12,24	12,36	12,48	12,6	12,72	12,84	12,96	13,08	13,2	Volts
R _U =	367.91	165.95	98.64	64.98	44.78	31.32	21.70	14.49	8.88	4.39	KOhms
Trim down	1	2	3	4	5	6	7	8	9	10	%
V _{out} =	11,88	11,76	11,64	11,52	11,4	11,28	11,16	11,04	10,92	10,8	Volts
R _D =	460.99	207.95	123.60	81.42	56.12	39.25	27.20	18.16	11.13	5.51	KOhms

RP15-, RP20-, RP30-, RP40-, RP60- xx15S

(For RP15-SA/SAW and RP15-SO/SOW see next page)

Trim up	1	2	3	4	5	6	7	8	9	10	%
V _{out} =	15,15	15,3	15,45	15,6	15,75	15,9	16,05	16,2	16,35	16,5	Volts
R _U =	404.18	180.59	106.06	68.80	46.44	31.53	20.88	12.90	6.69	1.72	KOhms
Trim down	1	2	3	4	5	6	7	8	9	10	%
V _{out} =	14,85	14,7	14,55	14,4	14,25	14,1	13,95	13,8	13,65	13,5	Volts
R _D =	499.82	223.41	131.27	85.20	57.56	39.14	25.97	16.10	8.42	2.282	KOhms

Trim Tables

RP15-S_DA, RP15 S:DAW Output Voltage Trim Tables

RP15-xx3.3SA, RP15-xx3.3SAW, RP15-xx3.3SO, RP15-xx3.3SOW

Trim up	1	2	3	4	5	6	7	8	9	10	%
Vout =	3,333	3,366	3,399	3,432	3,465	3,498	3,531	3,564	3,597	3,63	Volts
R _U =	385.07	191.51	126.99	94.73	75.37	62.47	53.25	46.34	40.96	36.66	KOhms
Trim down	1	2	3	4	5	6	7	8	9	10	%
Vout =	3,267	3,234	3,201	3,168	3,135	3,102	3,069	3,036	3,003	2,97	Volts
R _D =	116.72	54.78	34.13	23.81	17.62	13.49	10.54	8.32	6.60	5.23	KOhms

RP15-xx05SA, RP15-xx05SAW, RP15-xx05SO, RP15-xx05SOW

Trim up	1	2	3	4	5	6	7	8	9	10	%
Vout =	5,05	5,1	5,15	5,2	5,25	5,3	5,35	5,4	5,45	5,5	Volts
R _U =	253.45	125.70	83.12	61.82	49.05	40.53	34.45	29.89	26.34	23.50	KOhms
Trim down	1	2	3	4	5	6	7	8	9	10	%
Vout =	4,95	4,9	4,85	4,8	4,75	4,7	4,65	4,6	4,55	4,5	Volts
R _D =	248.34	120.59	78.01	56.71	43.94	35.42	29.34	24.78	21.23	18.39	KOhms

RP15-xx12SA, RP15-xx12SAW, RP15-xx12SO, RP15-xx12SOW

Trim up	1	2	3	4	5	6	7	8	9	10	%
Vout =	12,12	12,24	12,36	12,48	12,6	12,72	12,84	12,96	13,08	13,2	Volts
R _U =	203.22	99.06	64.33	46.97	36.56	29.61	24.65	20.93	18.04	15.72	KOhms
Trim down	1	2	3	4	5	6	7	8	9	10	%
Vout =	11,88	11,76	11,64	11,52	11,4	11,28	11,16	11,04	10,92	10,8	Volts
R _D =	776.56	380.72	248.78	182.81	143.22	116.83	97.98	83.85	72.85	64.06	KOhms

RP15-xx15SA, RP15-xx15SAW, RP15-xx15SO, RP15-xx15SOW

Trim up	1	2	3	4	5	6	7	8	9	10	%
Vout =	15,15	15,3	15,45	15,6	15,75	15,9	16,05	16,2	16,35	16,5	Volts
R _U =	161.56	78.22	50.45	36.56	28.22	22.67	18.70	15.72	13.41	11.56	KOhms
Trim down	1	2	3	4	5	6	7	8	9	10	%
Vout =	14,85	14,7	14,55	14,4	14,25	14,1	13,95	13,8	13,65	13,5	Volts
R _D =	818.22	401.56	262.67	193.22	151.56	123.78	103.94	89.06	77.48	68.22	KOhms

Trim Tables

Dual Output Voltage Trim Tables

RP15-, RP20- xx05D

Trim up	1	2	3	4	5	6	7	8	9	10	%
Vout =	10,1	10,2	10,3	10,4	10,5	10,6	10,7	10,8	10,9	11	Volts
R _U =	90.30	40.60	24.03	15.75	10.78	7.47	5.1	3.32	1.94	0.84	KOhms
Trim down	1	2	3	4	5	6	7	8	9	10	%
Vout =	9,9	9,8	9,7	9,6	9,5	9,4	9,3	9,2	9,1	9	Volts
R _D =	109.3	49.00	28.90	18.85	12.82	8.80	5.93	3.77	2.10	0.76	KOhms

RP15-, RP20, RP30- xx12D

Trim up	1	2	3	4	5	6	7	8	9	10	%
Vout =	24,24	24,48	24,72	24,96	25,2	25,44	25,68	25,92	26,16	26,4	Volts
R _U =	218.21	98.10	58.07	38.05	26.04	18.03	12.32	8.03	4.69	2.02	KOhms
Trim down	1	2	3	4	5	6	7	8	9	10	%
Vout =	23,76	23,52	23,28	23,04	22,8	22,56	22,32	22,08	21,84	21,6	Volts
R _D =	273.44	123.02	72.87	47.80	32.76	22.73	15.57	10.20	6.02	2.67	KOhms

RP15-, RP20-, RP30-- xx15D

Trim up	1	2	3	4	5	6	7	8	9	10	%
Vout =	30,3	30,6	30,9	31,2	31,5	31,8	32,1	32,4	32,7	33	Volts
R _U =	268.29	120.64	71.43	46.82	32.06	22.21	15.1	9.91	5.81	2.53	KOhms
Trim down	1	2	3	4	5	6	7	8	9	10	%
Vout =	29,7	29,4	29,1	28,8	28,5	28,2	27,9	27,6	27,3	27	Volts
R _D =	337.71	152.02	90.13	59.18	40.61	28.23	19.39	12.76	7.60	3.47	KOhms

Undervoltage Lockout

Undervoltage Lockout

At low input voltages, the input currents can exceed the rating of the converter. Therefore, converters featuring under-

voltage lockout will automatically shut down if the input voltage is too low. As the input voltage rises, they will restart.

Undervoltage Lockout Tables

Converter Series	Nominal Input Voltage	Switch ON input voltage	Switch OFF input voltage
RP08-S_DAW	24V (9~36VDC)	9VDC	8VDC
	48V (18~75VDC)	18VDC	16VDC
RP12-S_DA	12V (9~18VDC)	9VDC	8VDC
	24V (18~36VDC)	18VDC	16VDC
	48V (36~75VDC)	36VDC	33VDC
RP12-S_DAW	24V (9~36VDC)	9VDC	8VDC
	48V (18~75VDC)	18VDC	16VDC
RP15-S_DA, RP15-S_DO	12V (9~18VDC)	9VDC	8VDC
	24V (18~36VDC)	17VDC	14.5VDC
	48V (36~75VDC)	33VDC	30.5VDC
RP15-S_DAW, RP15-S_DOW	24V (9~36VDC)	9VDC	8VDC
	48V (18~75VDC)	18VDC	16VDC
RP15-S_DFW	24V (9~36VDC)	9VDC	7.5VDC
	48V (18~75VDC)	18VDC	15VDC
RP20-S_DFW	24V (9~36VDC)	9VDC	7.5VDC
	48V (18~75VDC)	18VDC	15VDC
RP30-S_DE	12V (9~18VDC)	9VDC	8VDC
	24V (18~36VDC)	17.8VDC	16VDC
	48V (36~75VDC)	36VDC	33VDC
RP30-S_DEW	24V (10~40VDC)	10VDC	8VDC
	48V (18~75VDC)	18VDC	16VDC
RP40-S_D_TG	12V (9~18VDC)	9VDC	8VDC
	24V (18~36VDC)	17.8VDC	16VDC
	48V (36~75VDC)	36VDC	34VDC
RP30-S_DGW	24V (9~36VDC)	9VDC	8VDC
	48V (18~75VDC)	18VDC	16VDC
RP60-SG	24V (18~36VDC)	17VDC	15VDC
	48V (36~75VDC)	34VDC	32VDC

Thermal Management- The Laws of Thermodynamics

Smaller, more powerful, better performance ...are the buzzwords in the area of DC/DC module power supplies. Good thermal management of the heat generated has become an important part of the design-process. But what needs to be done?

An indisputable fact is that the efficiency of any energy conversion process is always less than 100%. This means that a part of the energy being converted goes astray as heat and that ultimately this waste heat must be removed. The laws of thermodynamics state that heat energy can only flow from a warmer to a colder environment. So, for DC/DC converters, this means that if the internal heat is to be dissipated out of the module, that the ambient temperature must always be lower than the maximum allowable internal temperature. The larger this difference, the more effectively waste heat can flow out of the converter.

But which temperature specifications in the datasheets are to be consulted for the thermal calculations? RECOM declares two values in its datasheets, Operating Temperature Range (with or without derating) and the Maximum Case Temperature. Some manufacturers even claim that these two values are the same.

The case (surface) temperature of DC/DC modules are typically given as around +100°C. This value appears at first to be very high; however this figure includes not only the self-warming through internal losses but also the ambient temperature itself.

Remember: The smaller the difference between case surface and ambient, so the smaller the amount of heat that can be lost to the surroundings. If a converter has high internal dissipation, then it will be more affected by a small temperature difference than a converter with low internal dissipation. The internal losses occur mainly through switching losses in the transistors, rectification losses, core losses in the transformer and resistive losses in the windings and tracks. The maximum allowable internal temperature is determined by either the curie temperature of the transformer core material, the maximum junction temperature of the switching transistors or rectification diodes or the maximum operating temperature of the capacitors: whichever is the lowest.

Thermal Management- Thermal Impedance

The Thermal Impedance is a measure of how effectively heat can flow from inside the converter to its surroundings. It is measured in °C/Watt. It is possible to further lower the thermal resistance to ambient by fitting an external heat sink as this increases the surface area from which heat can be transferred to the surrounding air. The thermal impedance can also be lowered by blowing air across the converter as moving air can transfer more heat away from the converter as stationary air.

Recom datasheets always show the thermal impedance without a heatsink and with natural convection (still air).

The datasheets also state the minimum and maximum ambient operating temperature rather than just the maximum case temperature because this is easiest for the end user to measure and to monitor. The advantage is that true ambient temperature can be measured in the actual application and it need not be calculated theoretically, plus the results are valid for both sealed and vented constructions with a through-flow of cooling air.

Nevertheless, the maximum case temperature is useful to decide on a suitably dimensioned heat sink so that the maximum case temperature is not exceeded at the maximum ambient temperature.

The internal losses and thermal resistances can also be derived mathematically. For the calculations, Ohm's Law of $R=V/I$ can be modified so that R becomes thermal resistance, V becomes temperature and I becomes power dissipation. The following equations can thus be derived:

$$R_{TH\text{case-ambient}} = \frac{T_{\text{case}} - T_{\text{ambient}}}{P_{\text{dissipation}}}$$

$$P_{\text{dissipation}} = P_{\text{in}} - P_{\text{out}} = \frac{P_{\text{out}}}{\eta(\text{oper})} - P_{\text{out}}$$

where
 $R_{TH\text{case-ambient}}$ = Thermal impedance (from the case to the ambient surroundings)
 T_{case} = Case temperature
 T_{ambient} = Environment temperature
 $P_{\text{dissipation}}$ = Internal losses
 P_{in} = Input power
 P_{out} = Output power
 $\eta(\text{oper})$ = efficiency under the given operating conditions

With help of the above formulae, the maximum allowable ambient temperature for a given set of operating conditions can be calculated - but it is important to remember that efficiency is dependent on both the output load and the input voltage.

The formulae also demonstrate that case temperature is not the same as operating temperature, as is so often falsely claimed.

A practical example:
 Take the RP30-4805SE with 80% load:
 What is the maximum operating temp?

From the datasheet text and graphs, the following information can be found:
 $R_{TH\text{case-ambient}} = 10^{\circ}\text{C/W}$
 $T_{\text{case}} = 100^{\circ}\text{C}$ maximum
 T_{ambient} = unknown

P dissipation must be calculated from:
 $P_{\text{out}} = 30 \times 80\% = 24\text{W}$
 $\eta(\text{oper}) = 90\%$ (from Eff vs Load Graph)
 $P_{\text{diss.}} = 24/0.9 - 24 = 2.66$ Watts.

Thus
 $10^{\circ}\text{C/W} = (100 - T_{\text{amb}}) / 2.66\text{W}$
 and $T_{\text{amb max.}} = 73.4^{\circ}\text{C}$

At 100% load, this figure reduces to 64.4°C

At 100% load and over the full input voltage range, this figure reduces further to 59.1°C

If the thermal dissipation calculations reveal that the DC/DC Module will overheat at the desired ambient operating temperature, then there are still a number of options available to reach a solution.

One option is to derate the converter, i.e, use a higher power converter running at less than full load. The derating diagrams in the datasheets essentially define the maximum load at any given temperature within the operating temperature range. The derating curves are in reality not so linear as they are declared in most datasheets. However, reliable manufacturers will always err on the safe side so that the values given can be safely relied on in practice.

If the converter has a plastic case, then the next largest case size with the same power rating could be chosen to increase the available surface area. However, care must be taken not to compromise on efficiency otherwise no net gain will be made.

Thermal Management-Heat Sinking

If the converter has a metal case, then adding a heat sink is can be very effective, particularly in conjunction with a forced-air cooling system. If a heat sink is used with fan cooling, then the thermal resistance equation becomes:

$$R_{TH\text{case-ambient}} = R_{TH\text{case-heatsink}} + R_{TH\text{heatsink-ambient}}$$

where

$$R_{TH\text{case-ambient}} = \text{Thermal impedance}$$

(from the case to the ambient surroundings)

$$R_{TH\text{case-heatsink}} = \text{Thermal impedance}$$

(from the case to the heat sink)

$$R_{TH\text{heatsink-ambient}} = \text{Thermal impedance}$$

(from the heat sink to ambient)

The value of $R_{TH\text{heatsink-ambient}}$ includes the thermal resistance of the heat sink as well as the thermal resistance of any thermally conductive paste or silicon pads used for a better thermal contact to the case. If these heat transfer aids are not applied, then a value of approximately 0.2 K/W must be added to the thermal resistance of the heat sink alone. When establishing of the value of $R_{TH\text{heatsink-ambient}}$ it is also necessary to know how much air is being blown across the heat sink fins. These values are most often given in lfm (linear feet per minute) and declared by the fan manufacturer. The conversion to m/s is $100\text{lfm} = 0.5\text{ m/s}$.

Calculation of heatsinks size:

Example: RP30-2405SEW starts derating without heatsink at +65°C but the desired operation is 30W at +75°C so the size of the heatsink has to be calculated.

$$P_{\text{out}} = 30\text{W}$$

$$\text{Efficiency} = 88\% \text{ max.}$$

$$P_{\text{d}} = \frac{P_{\text{out}}}{\text{Efficiency}} - P_{\text{out}} = \frac{30\text{W} - 30\text{W}}{88\%} = 4.1\text{W}$$

$$T_{\text{case}} = 100^{\circ}\text{C} \text{ (max. allowed case temperature)}$$

$$T_{\text{ambient}} = 75^{\circ}\text{C}$$

$$R_{TH\text{case-ambient}} = \frac{T_{\text{case}} - T_{\text{ambient}}}{P_{\text{D}}} = \frac{100^{\circ}\text{C} - 75^{\circ}\text{C}}{4.1^{\circ}\text{C}} = 6.1^{\circ}\text{C/W}$$

So it has to be ensured that the thermal resistance between case and ambient is 6,1°C/W max.

When mounting a heatsink on a case there is a thermal resistance $R_{TH\text{ case-heatsink}}$ between case and heatsink which can be reduced by using thermal conductivity paste but cannot be eliminated totally.

Heatsink mounted on case without thermal conductivity paste	$R_{TH\text{ case-heatsink}} = \text{ca. } 1 \dots 2^{\circ}\text{C/W}$
Heatsink mounted on case with thermal conductivity paste	$R_{TH\text{ case-heatsink}} = \text{ca. } 0,5 \dots 1^{\circ}\text{C/W}$
Heatsink mounted on case with thermal conductivity paste and electrical-isolation-film	$R_{TH\text{ case-heatsink}} = \text{ca. } 1 \dots 1,5^{\circ}\text{C/W}$

Therefore, If a heatsink is mounted on the converter, it's thermal resistance has to be at least:

$$R_{TH\text{case-ambient}} = R_{TH\text{case-heatsink}} + R_{TH\text{heatsink-ambient}} = 6.1^{\circ}\text{C/W} - 1^{\circ}\text{C/W} = 5.1^{\circ}\text{C/W}$$

If however, the results of your calculations or measurements are border-line, then the issue must be examined in more depth. So, for example, there is a difference in thermal performance between vertically and horizontally mounted modules, between static air and freely convecting air and with air at low atmospheric pressures.

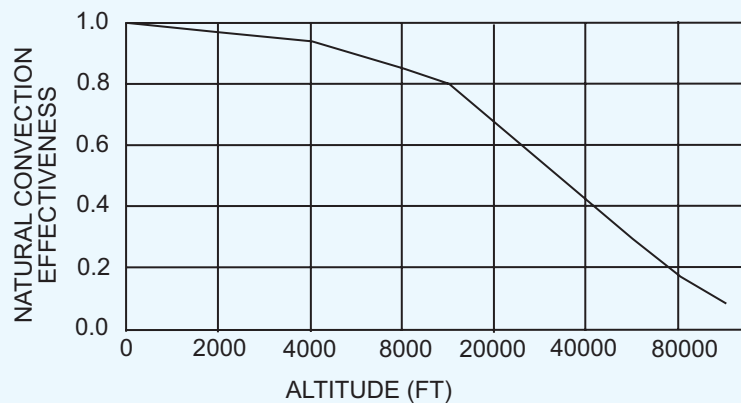

Heat Sinks available from Recom

7G-0047-F (12°C/W)

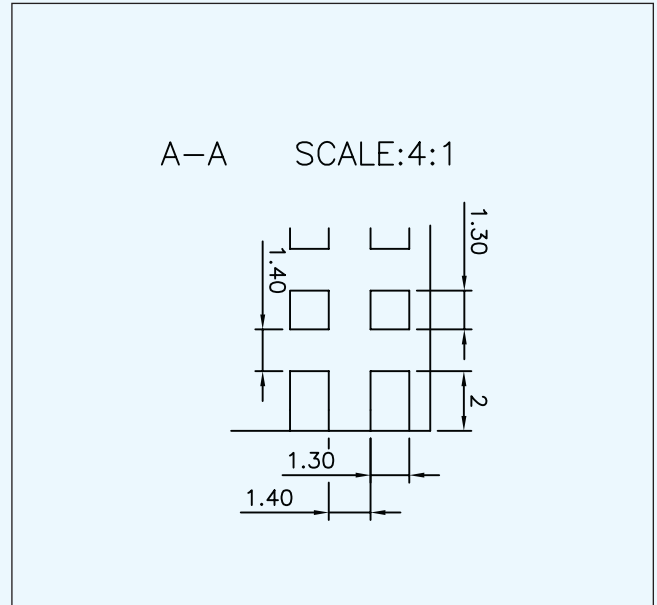
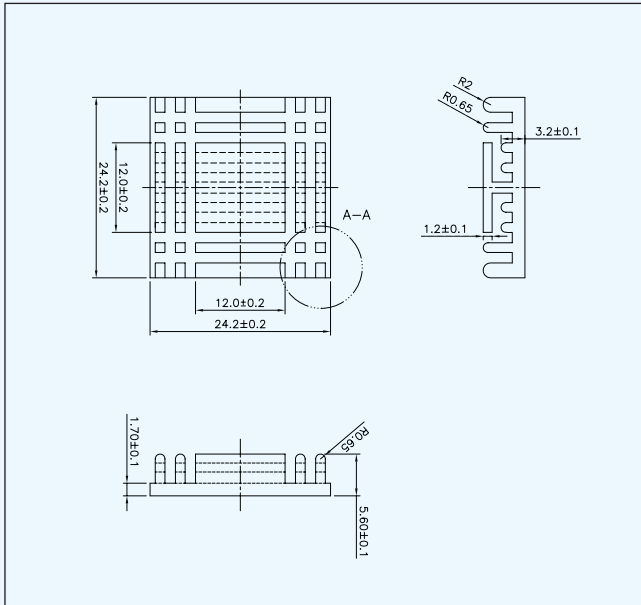

7G-0020C (9.5°C/W)

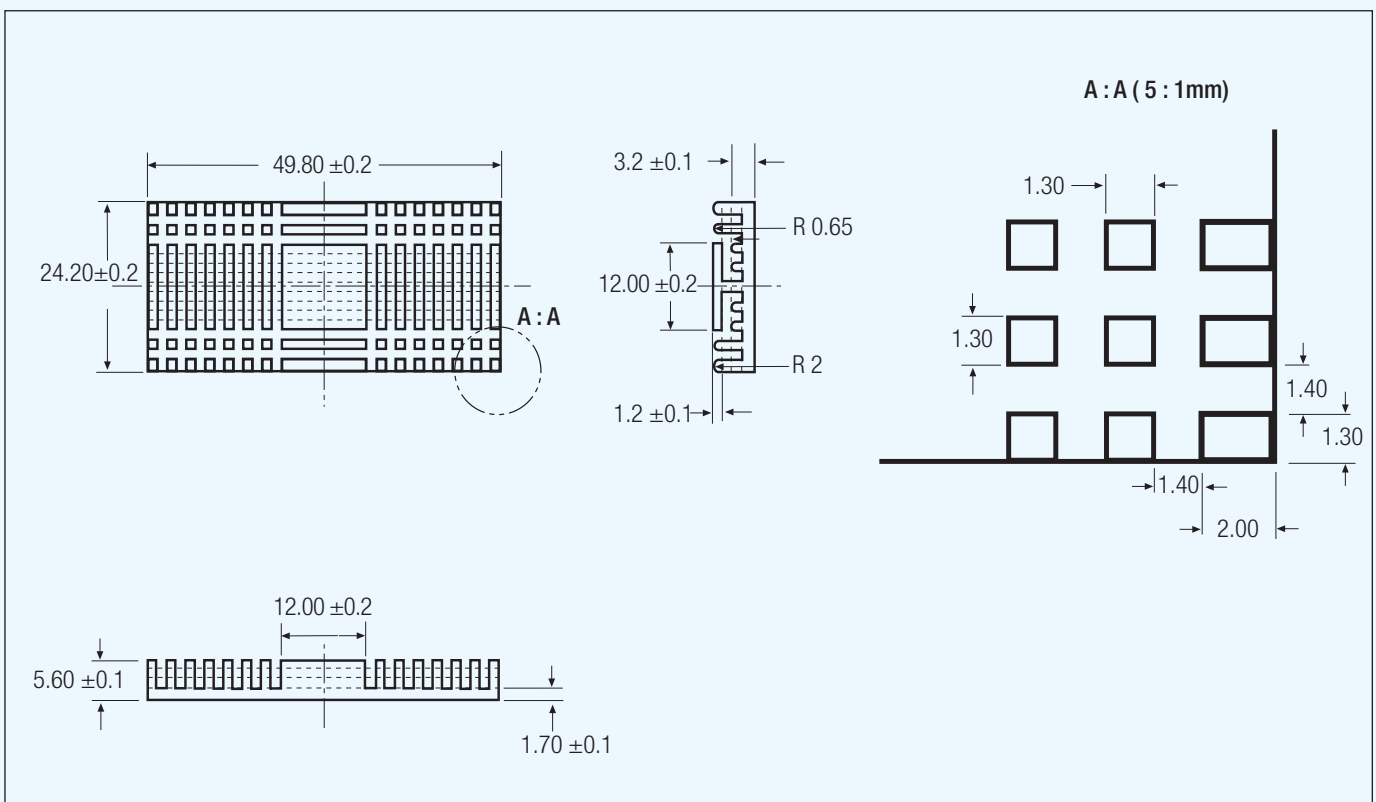

Heat Sinks available from Recom

7G-0011C (8.24°C/W)

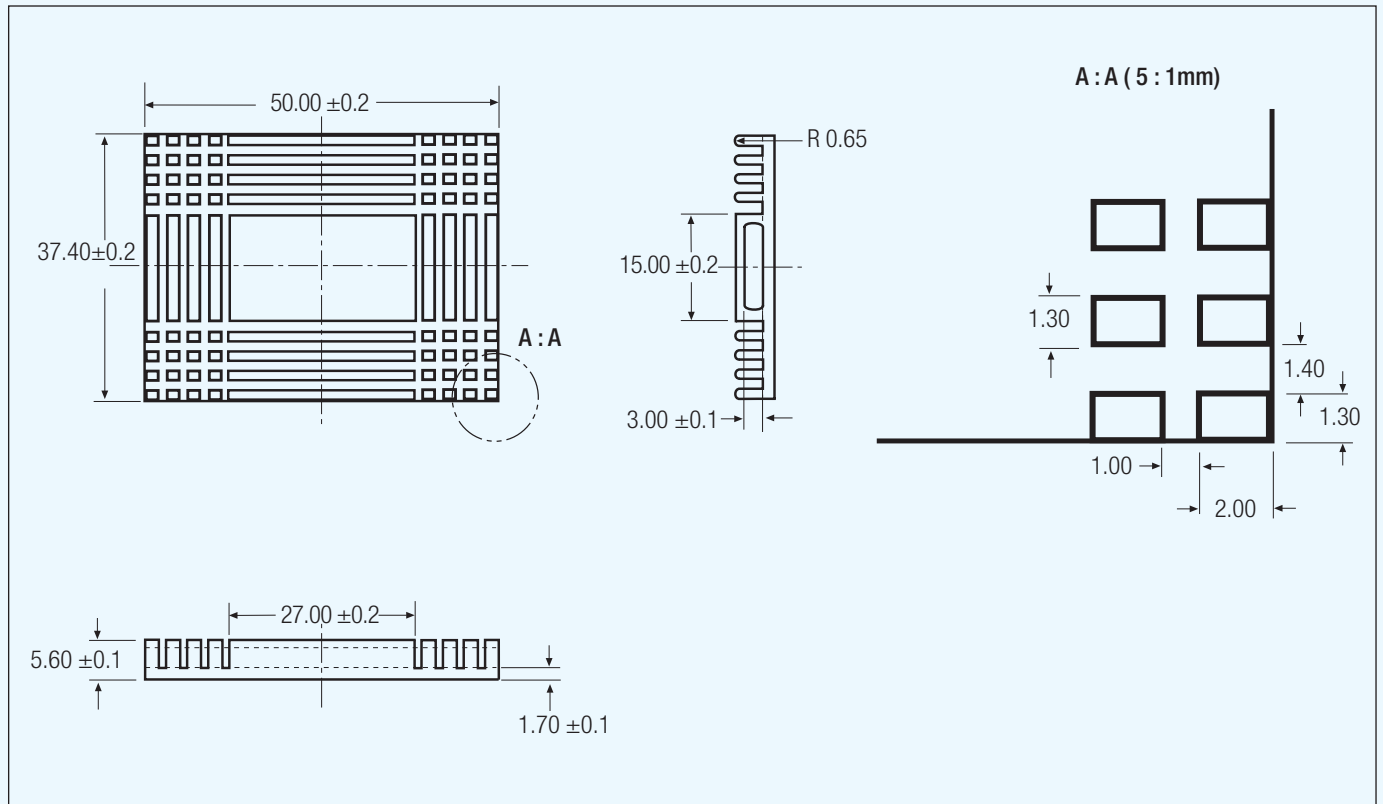

7G-0026C (7.8°C/W)

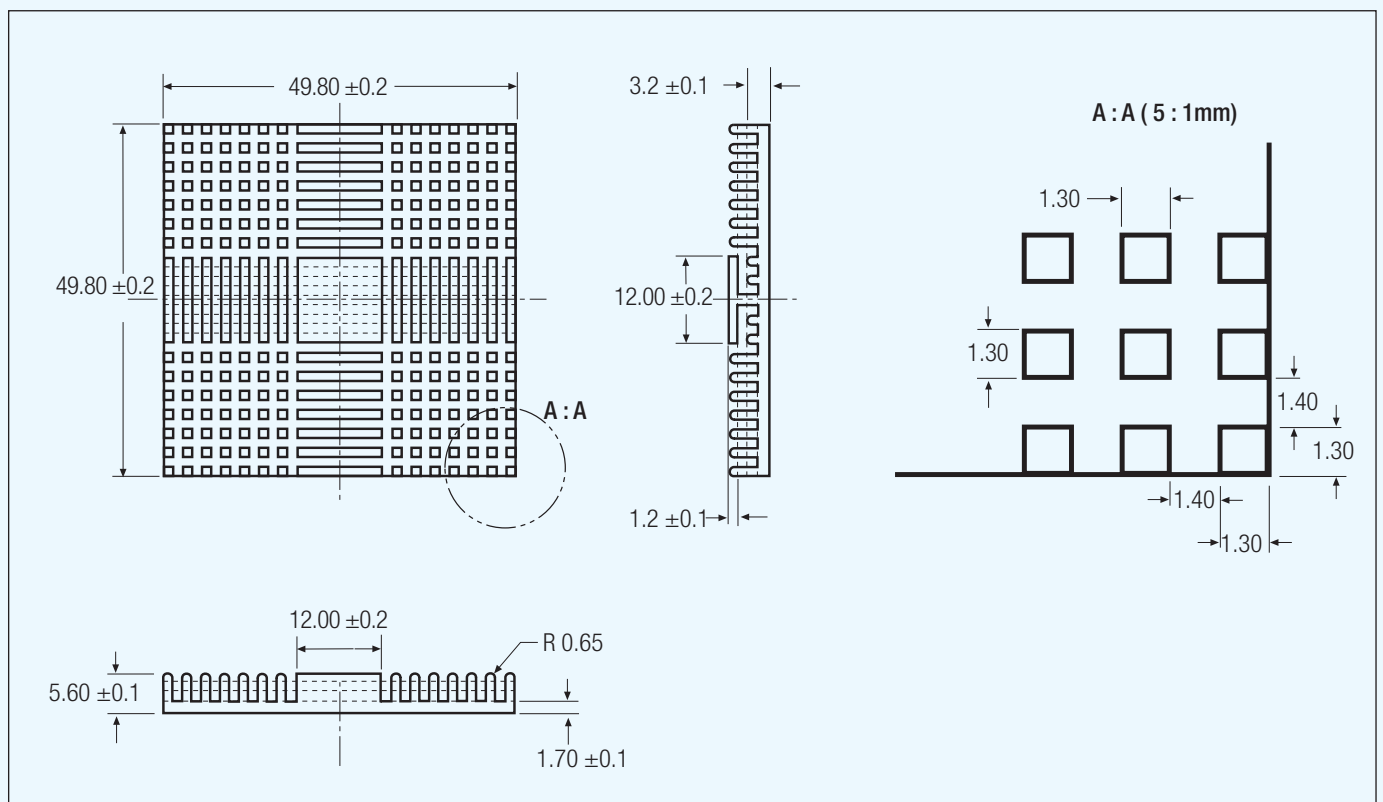

Input Fuse

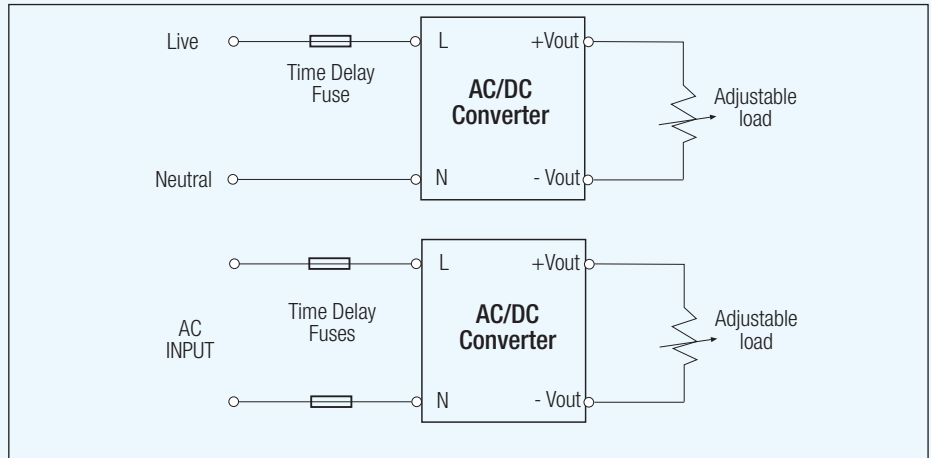

Note: An input fuse is recommended for safety and protection. A time-delay or slo-blo fuse should be fitted. If the AC connector is not-polarised, then fuses can be fitted to both inputs

Recommended Fuse Ratings

<40W	1.5Amp
40W	2 Amp
60W	3 Amp

Earthing

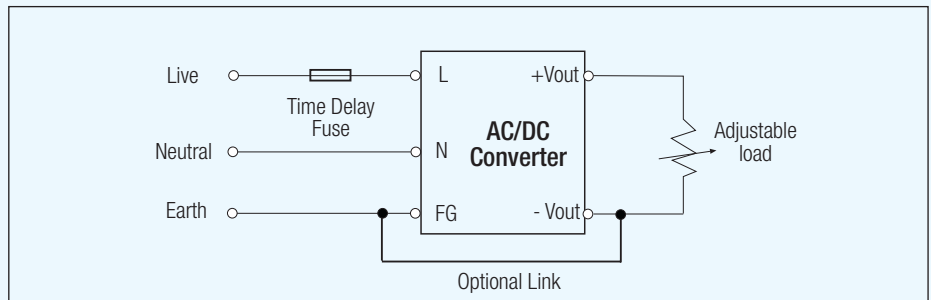

Note: If the converter has a ground pin (FG), then it must be earthed to a safety ground point.

Use thicker, shorter cables to ensure a good connection as this will also reduce the EMC interference.

-Vout can be also connected to FG to reference the output to Ground.

External Filter

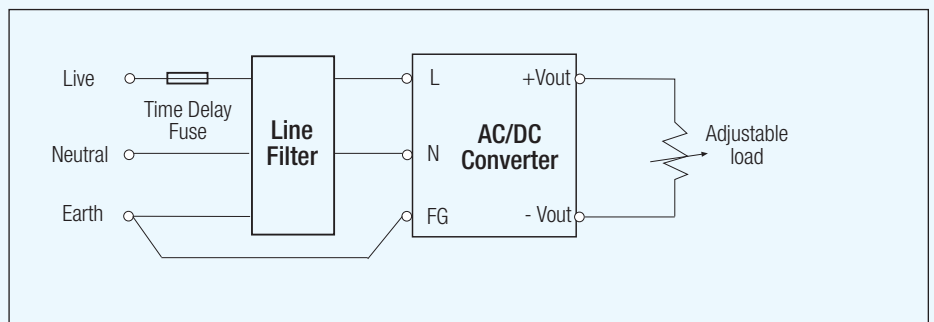

Note: The RECOM RAC series contain a built-in line filter to meet EN 55022 Class B Conducted Emissions.

If additional filtering is required, then an external line filter module can be fitted. The cabling between the external filter and the converter should be kept as short as possible and a central star-earth wiring should be used.

Combining Converters

-in Parallel

Note: AC/DC converters can be paralleled to increase the output voltage or to make a hot-swap circuit.

The inputs of two AC/DC converters cannot be wired in series to increase the input voltage range

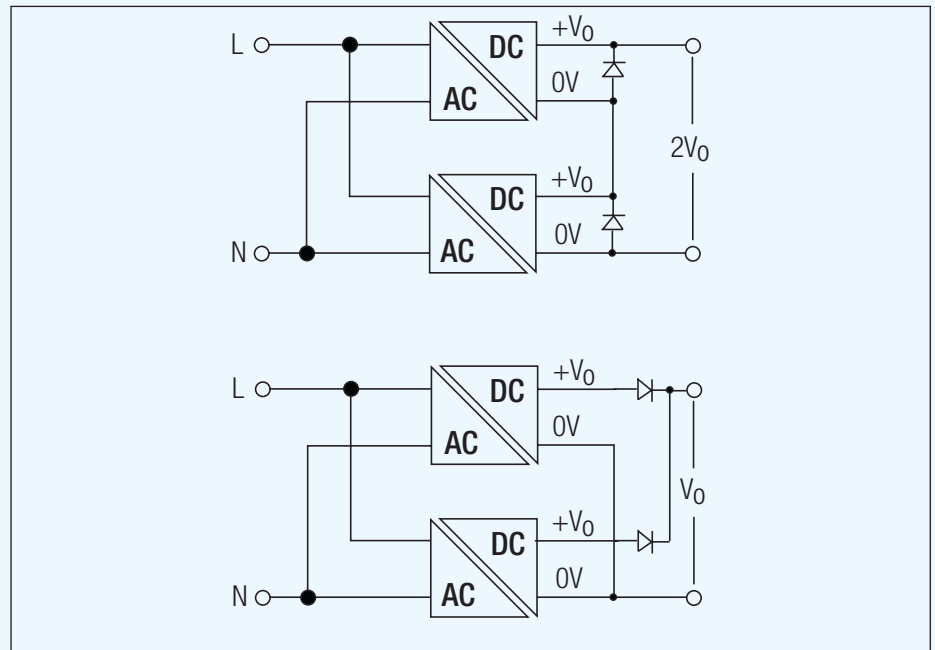

Combining Converters

-in Series

Note: A DC/DC converter or switching regulator can be powered from the output of an AC/DC converter to add an auxiliary output or negative rail.

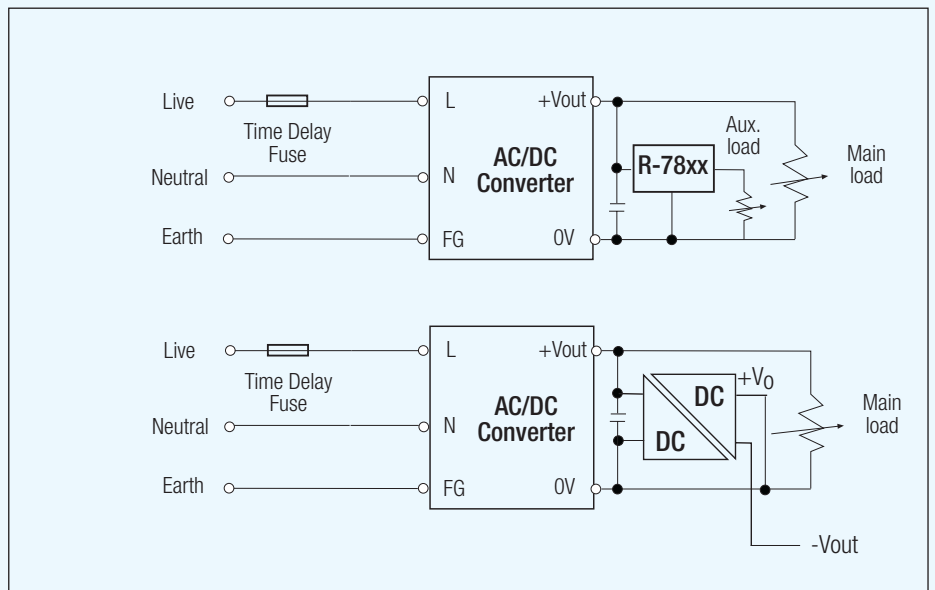

DC Inputs

Note: All AC/DC converters will also work with DC inputs.

Check the individual datasheets for the DC input voltage ranges.

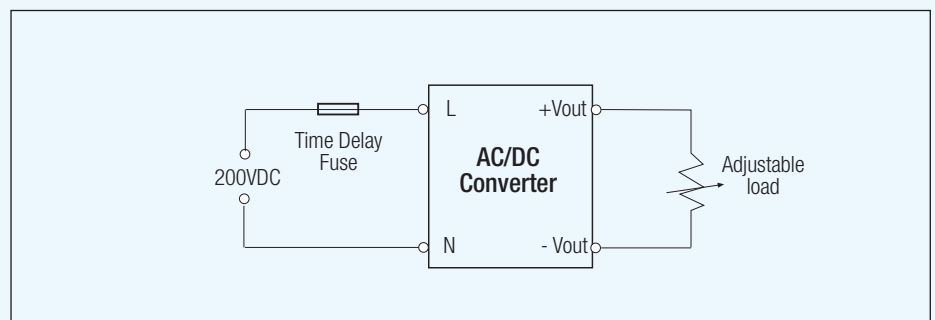

DC/DC Block Diagrams

Unregulated Single Output

RM, RL, RNM, RN, RQS, RO, RE,
ROM, RSS, R1S, RB-xxxxS,
RA-xxxxS, RBM-xxxxS, RK,
RP-xxxxS, RxxPxxS, RxxP2xxS,
R2S, RTS, RI, REZ, RKZ-xxxxS,
RV-xxxxS, RGZ

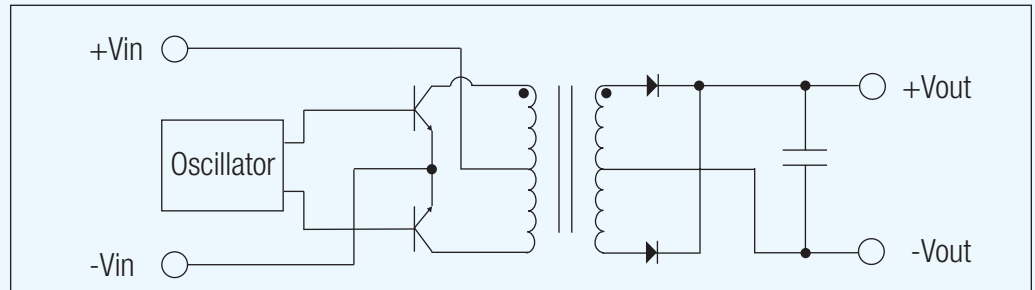

Unregulated Dual Output

RQD, RSD, R1D, RB-xxxxD,
RA-xxxxD, RBM-xxxxD, RH,
RP-xxxxD, RxxPxxD, RxxP2xxD,
RTD, R2D, RC-xxxxD, RD-xxxxD,
RKZ-xxxxD, RV-xxxxD, RJZ

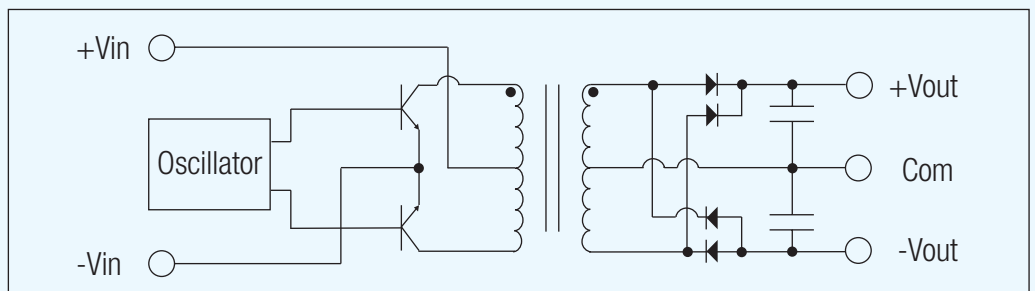

Unregulated Dual Isolated Output

RU, RUZ

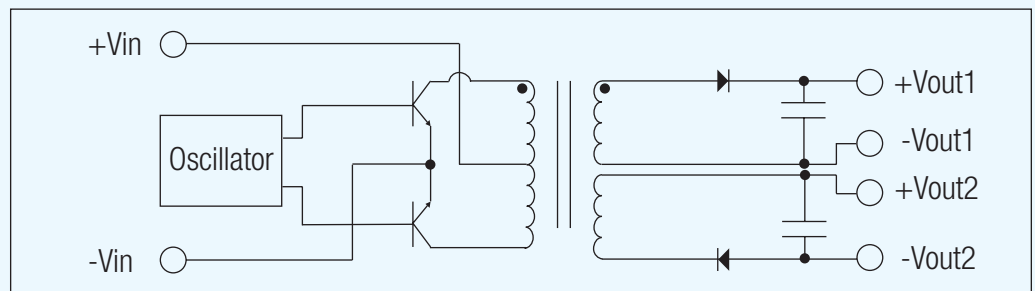

Post-Regulated Single Output

RZ, RSZ (P), RY-xxxxS, RX-xxxxS, REC3-xxxxSR/H1

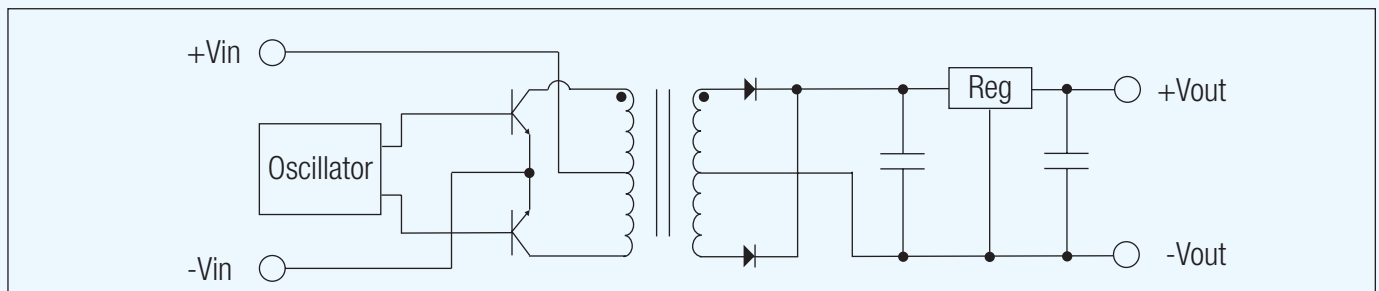

Post-Regulated Dual Output

RY-xxxxD, REC3-xxxxDR/H1

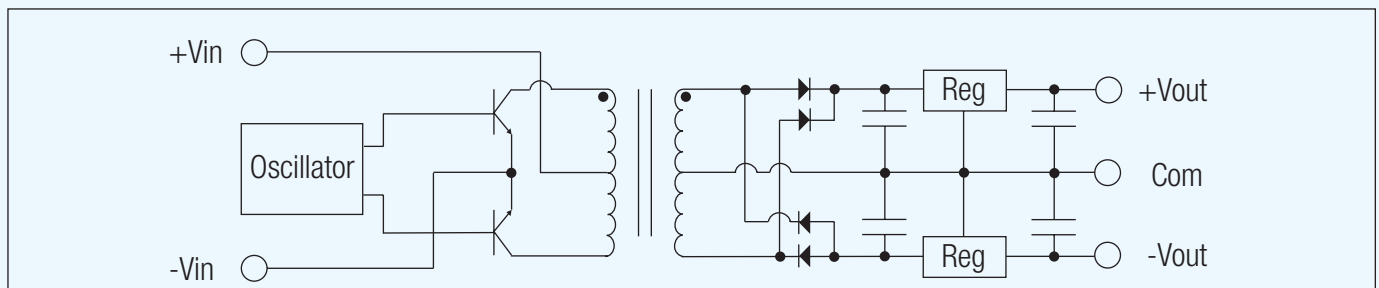

DC/DC Block Diagrams

Regulated Single Output

RS0, RS, RW-xxxxS, REC3-xxxxSRW(Z)/H*, REC5-xxxxSRW(Z)/H*, REC7.5-xxxxSRW/AM/H*, RP08-xxxxSA, RP08-xxxxSAW, RP10-xxxxSE, RP10-xxxxSEW, RP12-xxxxSA, RP12-xxxxSAW, RP15-xxxxSO, RP15-xxxxSOW, RP15-xxxxSA, RP15-xxxxSAW, RP15-xxxxSF, RP15-xxxxSFW, RP20-xxxxSF, RP20-xxxxSFW

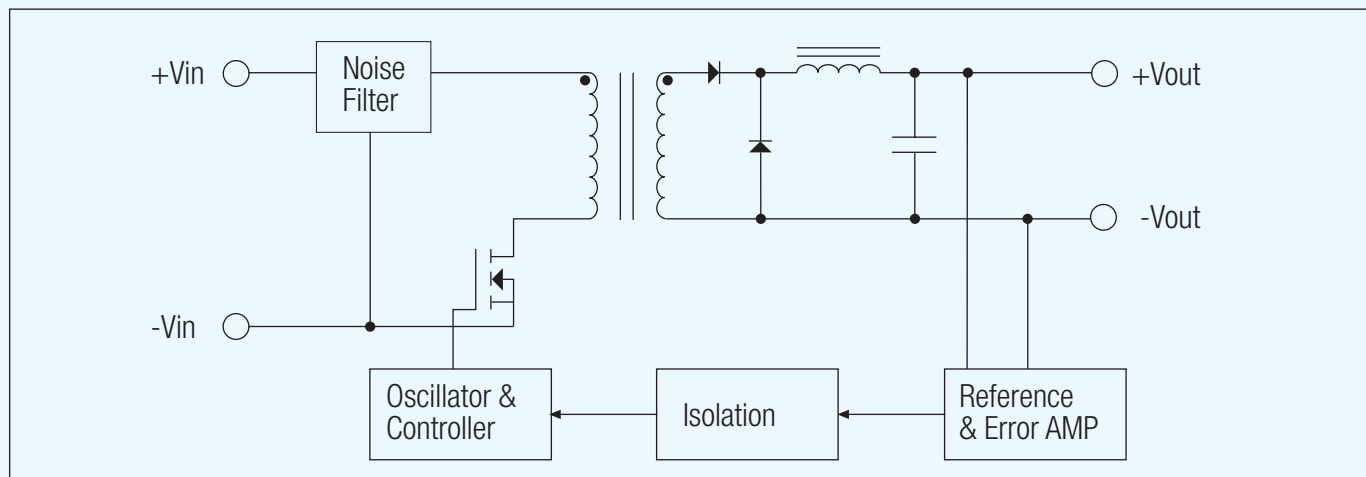

Regulated Dual Output

RS0-xxxxD, RS-xxxxD, RW-xxxxD, REC3-xxxxDRW(Z)/H*, REC5-xxxxDRW(Z)/H*, REC7.5-xxxxDRW/AM/H*, RP08-xxxxDA, RP08-xxxxDAW, RP10-xxxxDE, RP10-xxxxDEW, RP12-xxxxDA, RP12-xxxxDAW, RP15-xxxxDF, RP15-xxxxDFW, RP15-xxxxDA, RP15-xxxxDAW, RP20-xxxxDF, RP20-xxxxDFW, RP30-xxxxDE, RP30-xxxxDEW, RP40-xxxxDG, RP40-xxxxDGW

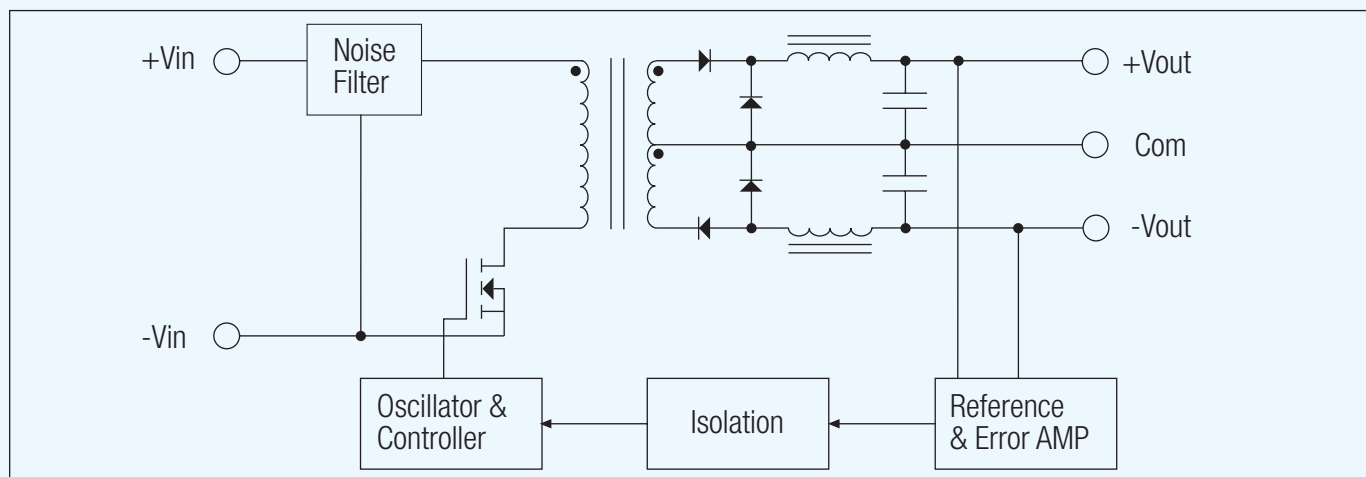

DC/DC Block Diagrams

Regulated Dual Output

RP40-05xxTG

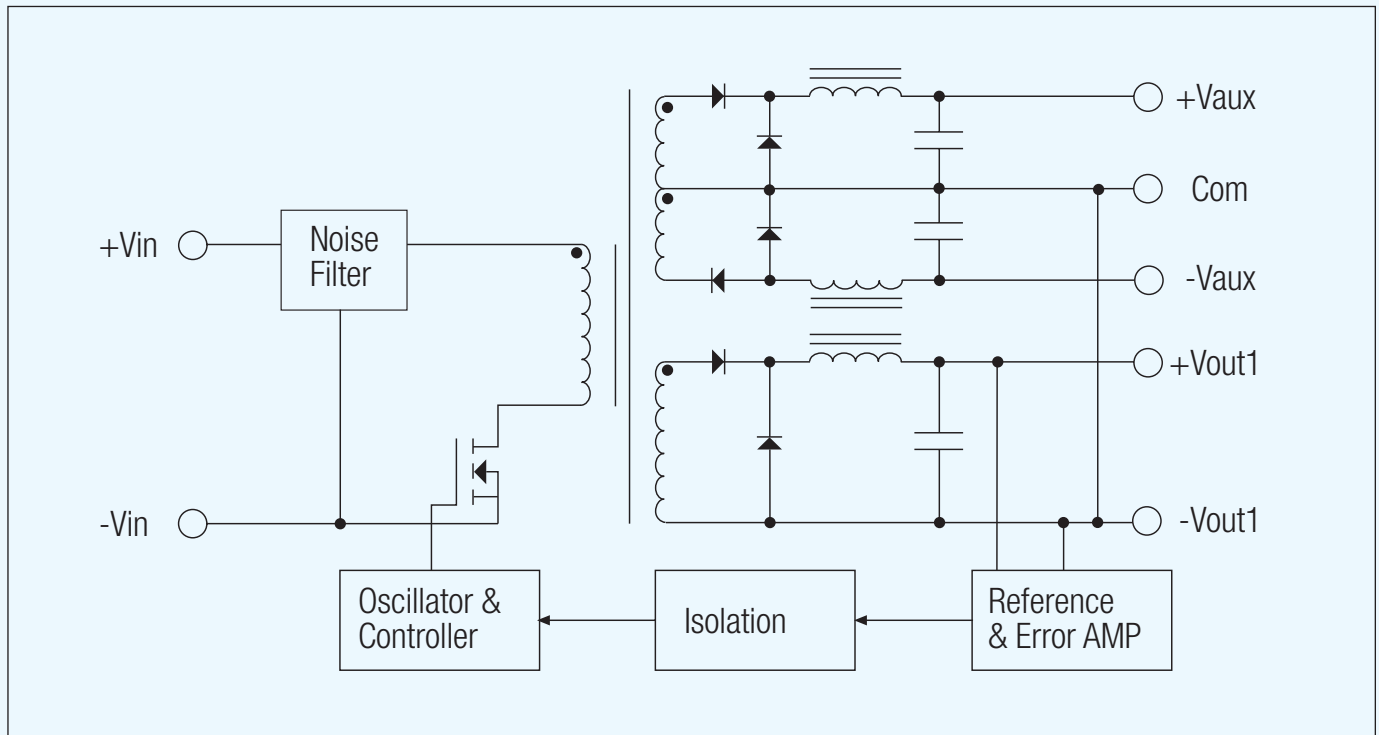

Regulated Single Output, Synchronous Rectification

RP20-xxxxSF, RP30-xxxxSE, RP30-xxxxSEW, RP40-xxxxSG, RP40-xxxxSGW, RP60-xxxxSG

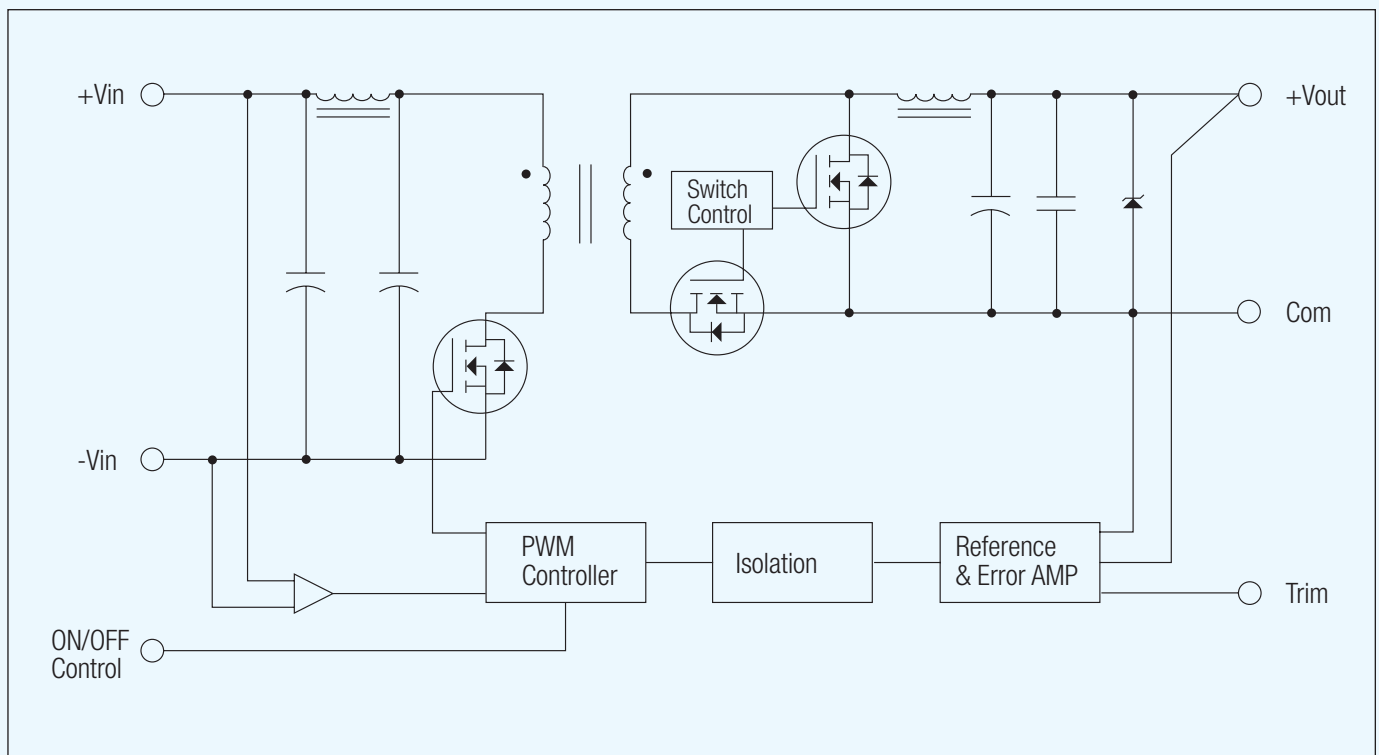

AC/DC Block Diagrams

RAC04-xxSA, RAC05-xxSA, RAC10-xxSA, RAC15-xxSA, RAC20-xxSA, RAC30-xxSA, RAC60-xxSB

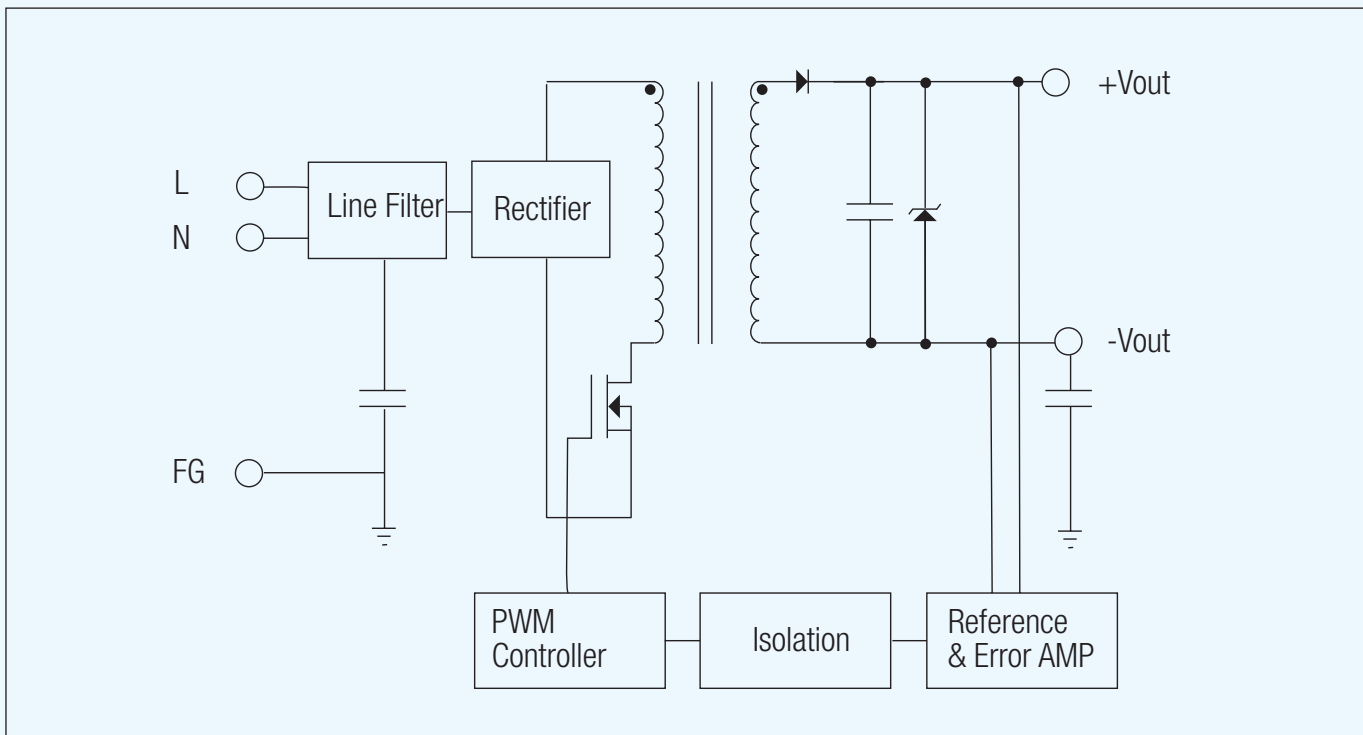

RAC05-xxSB, RAC10-xxSB, RAC15-xxSB, RAC30-xxSB, RAC40-xxSA

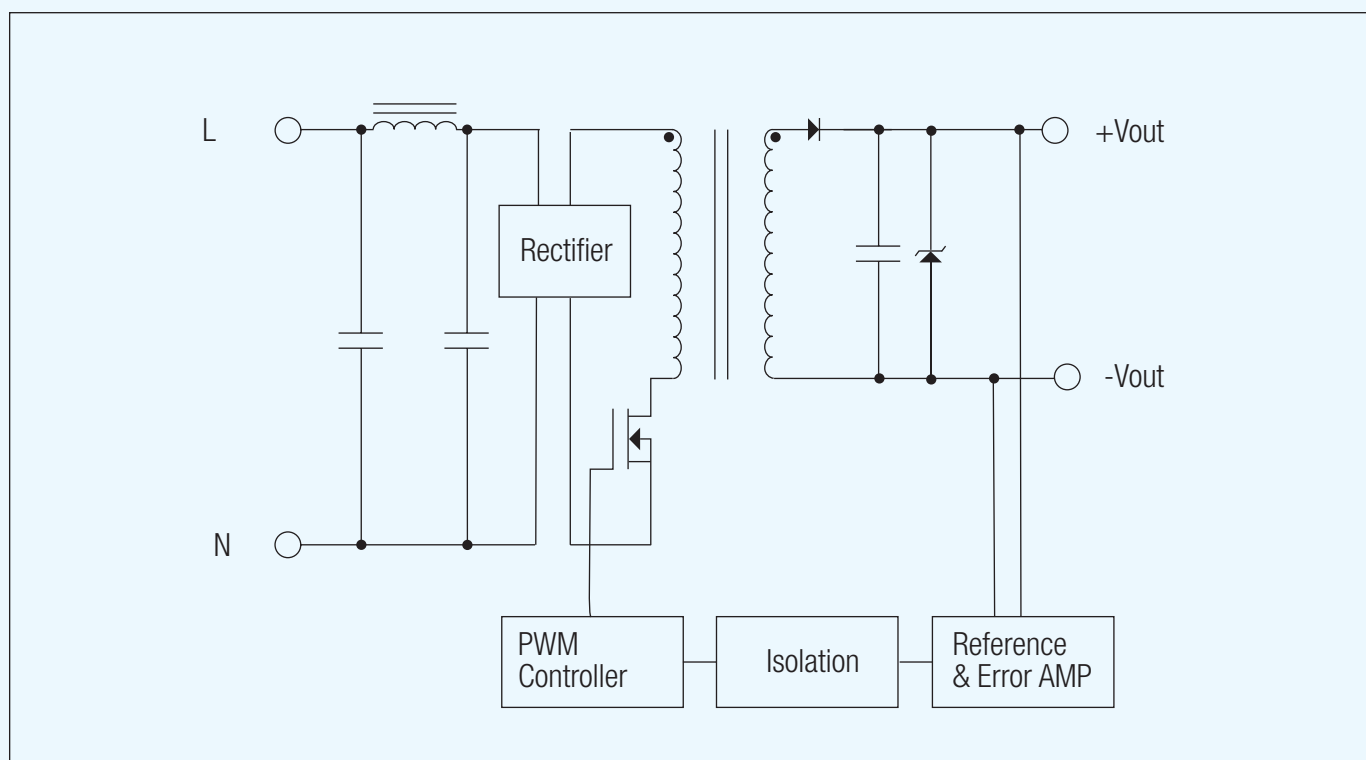

AC/DC Block Diagrams

RAC05-xxDA, RAC10-xxDA, RAC15-xxDA, RAC20-xxDA, RAC30-xxDA

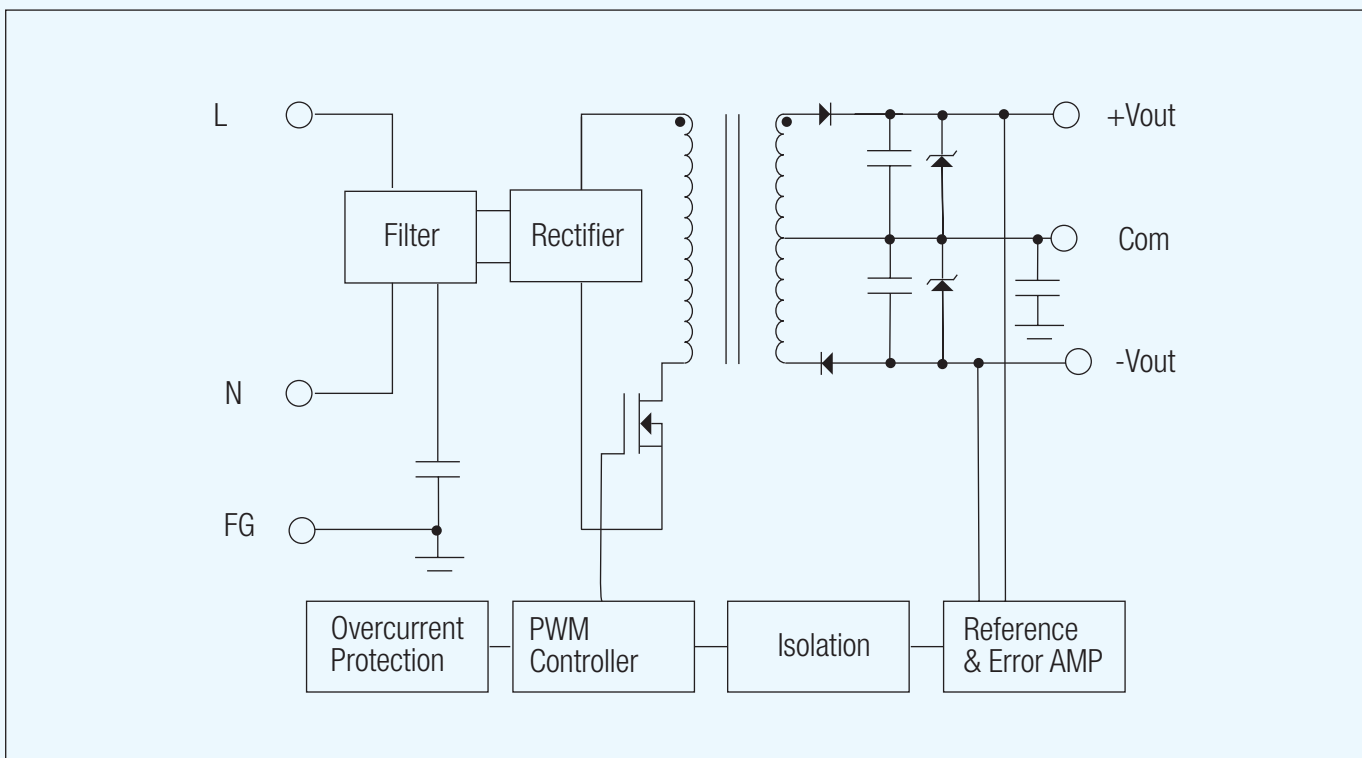

RAC15-xxDB, RAC30-xxDB, RAC40-xxSA

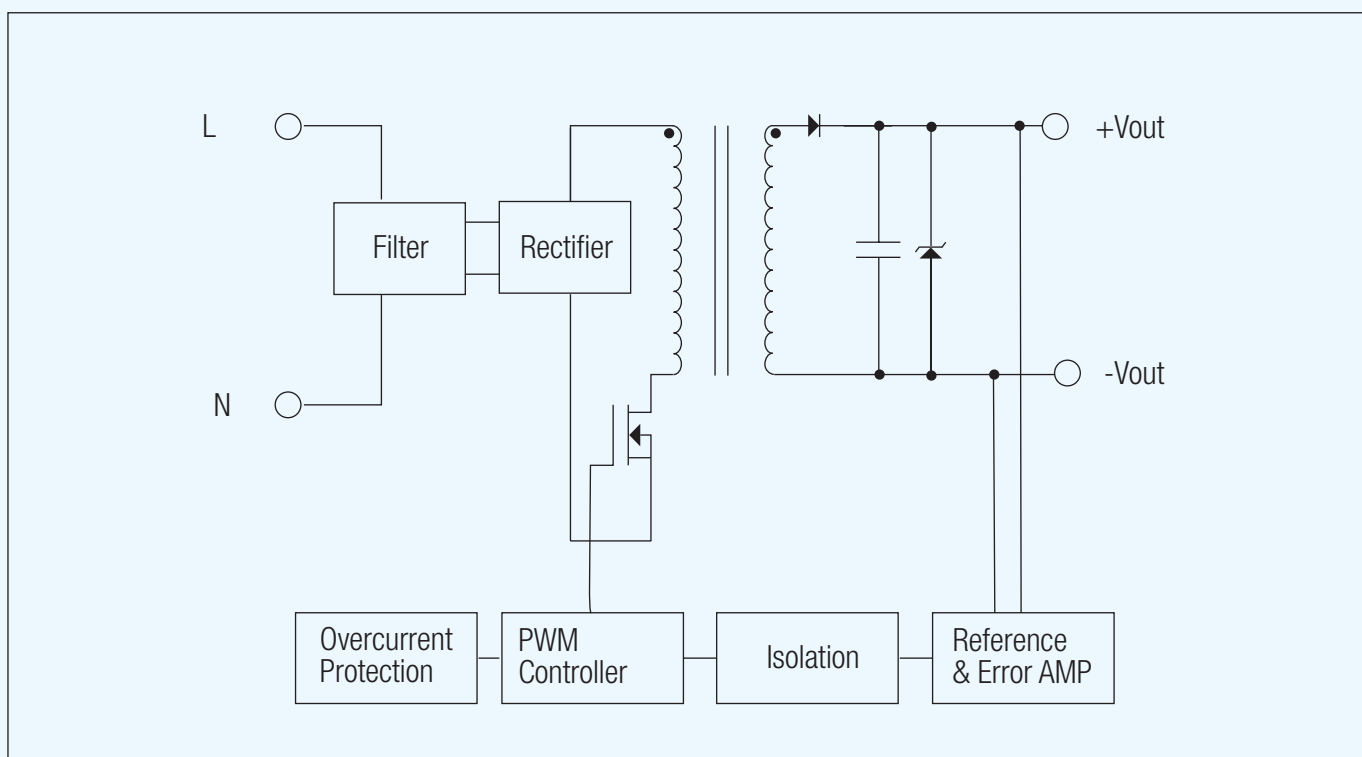

AC/DC Block Diagrams

RAC15-05xxTA, RAC20-05xxTA

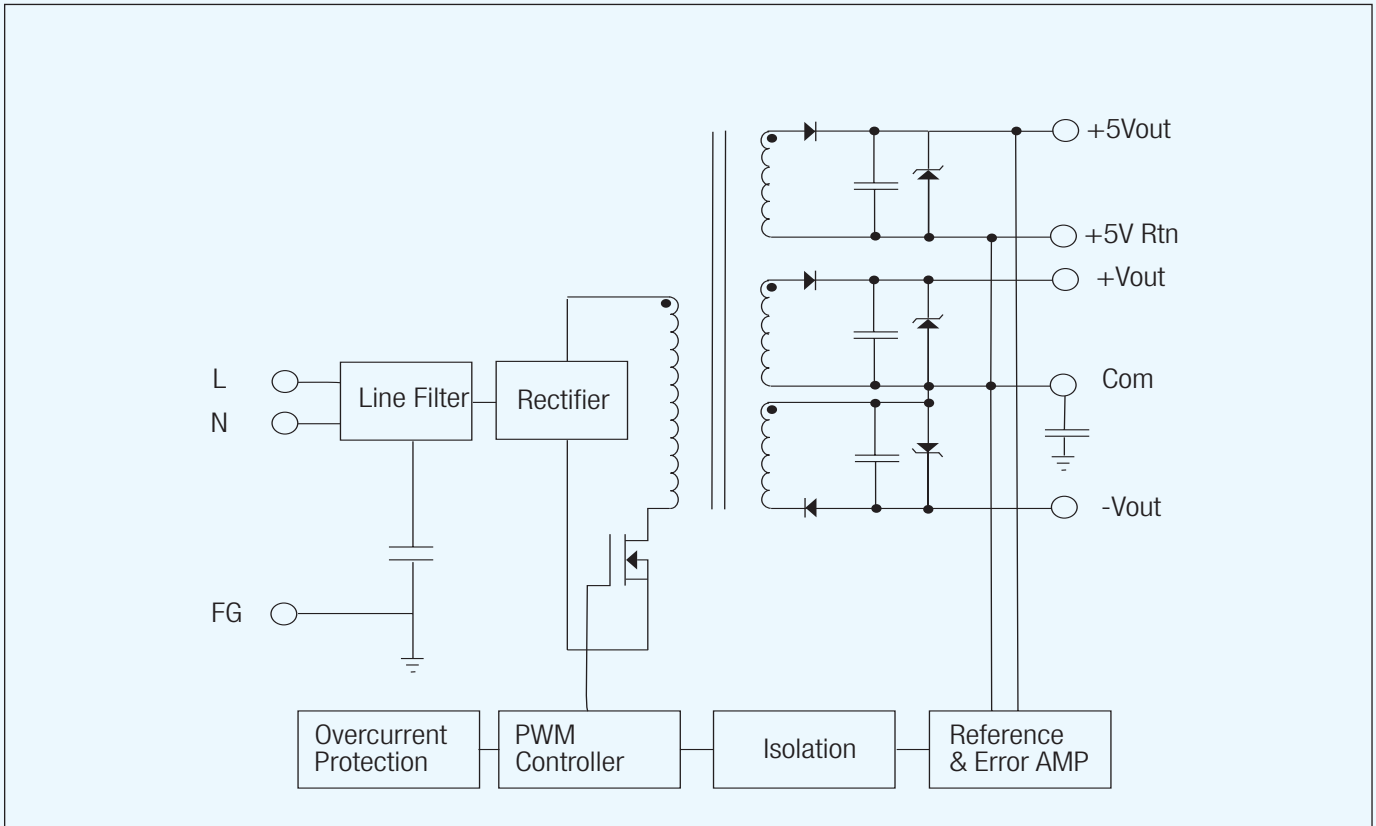

RAC15-05xxTB, RAC30-05xxTA, RAC40-05xxTA

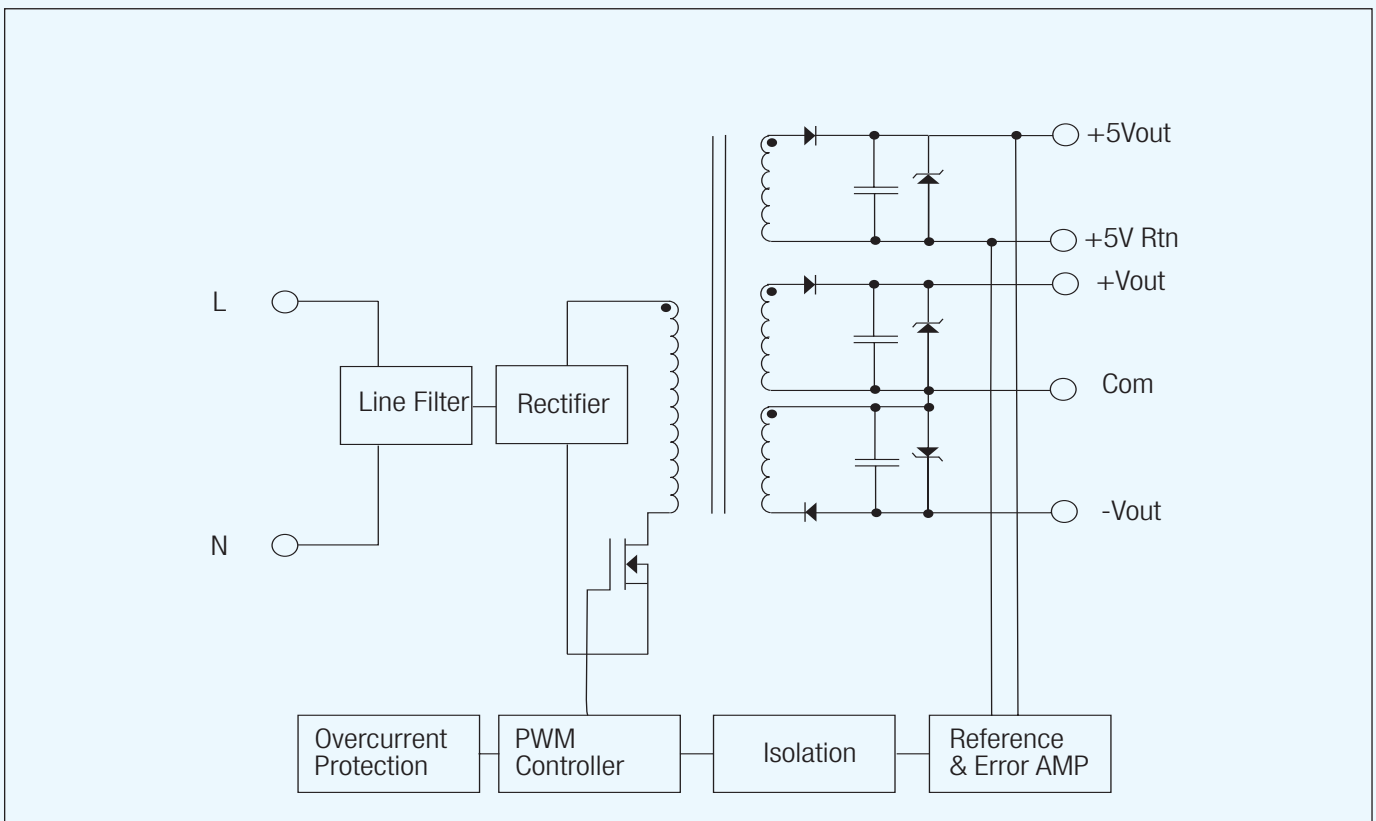

No.	Types
1.	RO, RM, RN, RNM, RE, ROM, RB, RBM, RK, RH, RP, RU, RI, RD, RKZ, RUZ, RY, R-78xx-0.5, R-78xx-1.0
2.	RS, RS0, RS3, RxxTR
3.	RJZ, RGZ, RW2(B)
4.	RSS, RSD, RZ, R1S, R1D
5.	RTD, RTS, RSZ, R-78Axx-xx SMD, R2S, R2D, R-78AAxx-xx SMD
6.	RV, RW-S, RxxPxx, RxxP2xx, RW2(A)-SMD
7.	R5-xxxxPA, R6xxxxP, R7xxxxP, RW-D, REC3-, REC3.5, REC5-, REC6-, REC7.5-
8.	RP08, RP12, RCD-24-xxx
9.	RP15-0, RP15-OW, RP15-A, RP15-AW,
10.	RP08-SMD, REC3-SMD, REC3.5-SMD, REC5-SMD, REC6-SMD, REC7.5-SMD
11.	RP10, RP15, RP20, RP30, RP40
12.	R-78Bxx-xx, R-78HBxx-xx
13.	R-78Bxx-xxL, R-78HBxx-xxL
14.	R5-xxxxDA, R6xxxxD, R7xxxxD

1.

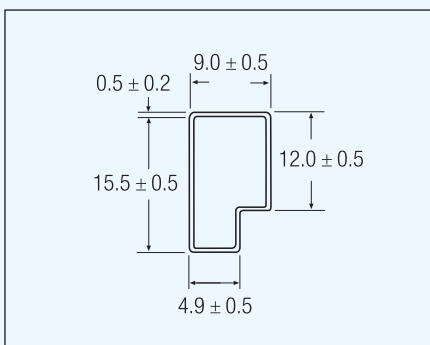

TUBE LENGTH = 520 ± 2.0

2.

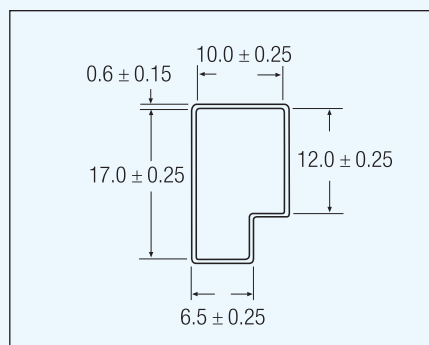

TUBE LENGTH = 520 ± 1.5

3.

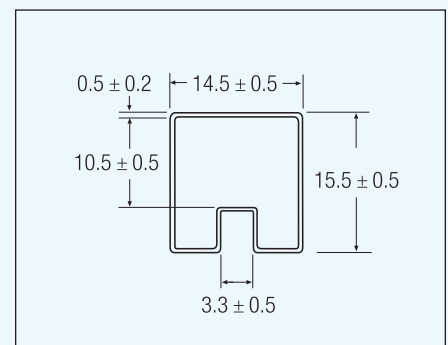

TUBE LENGTH = 520 ± 1.0

4.

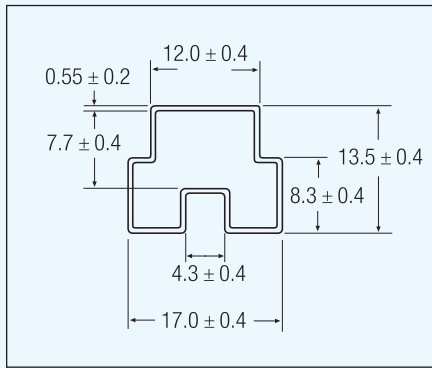

TUBE LENGTH = 530 ± 2.0

5.

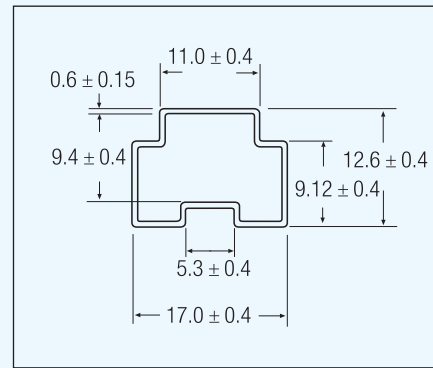

TUBE LENGTH = 530 ± 2.0

6.

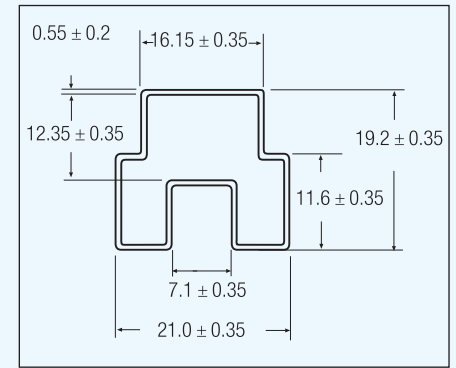

TUBE LENGTH = 530 ± 2.0

7.

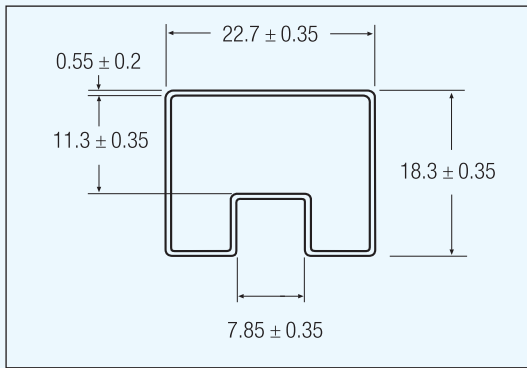

TUBE LENGTH = 530 ± 2.0

8.

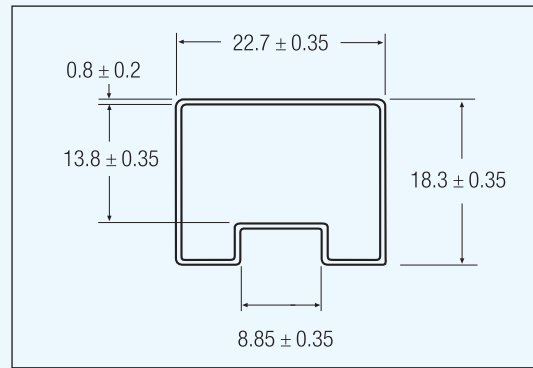

TUBE LENGTH = 530 ± 2.0

9.

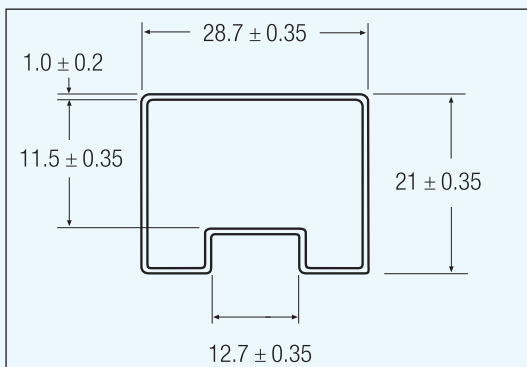

TUBE LENGTH = 530 ± 2.0

10.

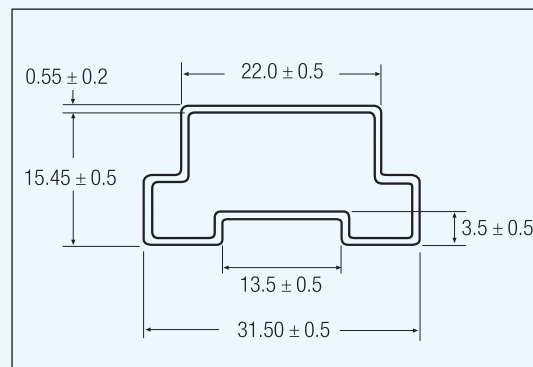

TUBE LENGTH = 530 ± 2.0

11.

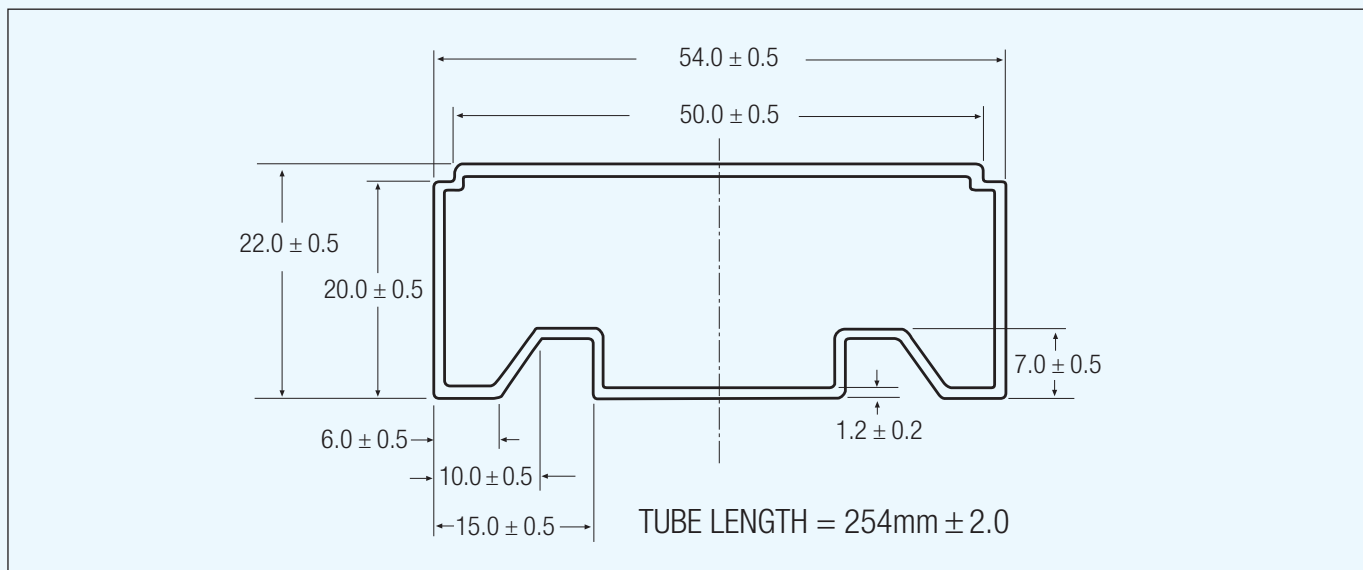

12.

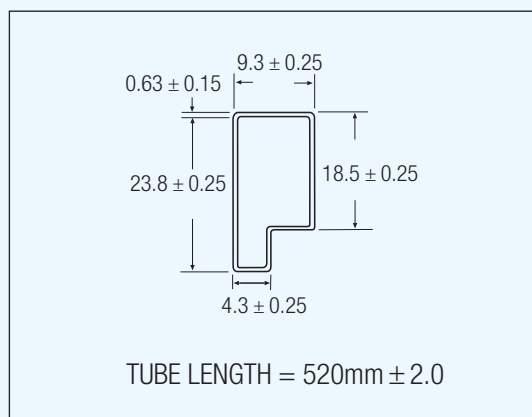

13.

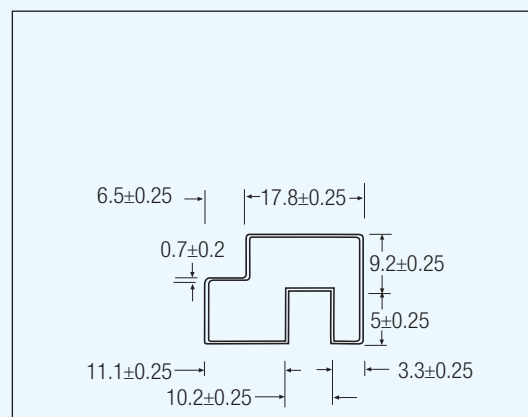

14.

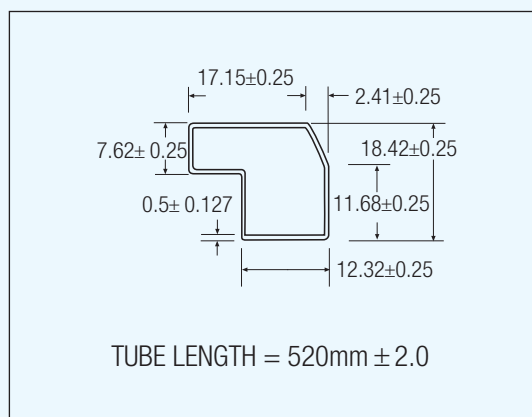

RSS(8)-xxxx & R1S(8)-xxxx tape outline dimensions

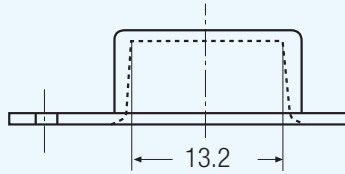

Sprocket hole $\varnothing 1.50+0.1/-0$
 Sprocket hole tolerance over any 10 pitches ± 0.2

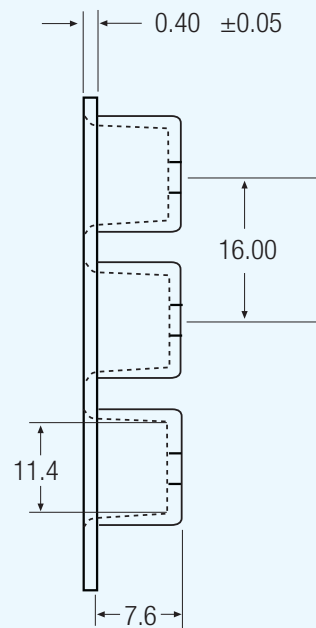
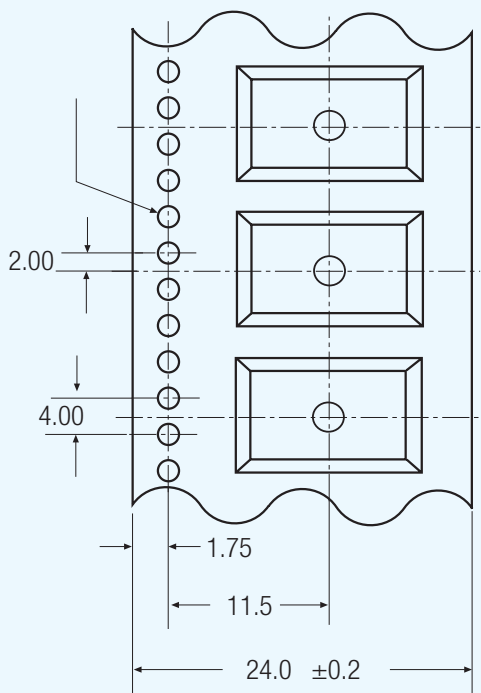

All dimensions in mm xx.xx ± 0.1

1. 10 sprocket hole pitch cumulative tolerance ± 0.20
2. All dimensions meet EIA-481-2 requirements
3. Component load per 13" reel : 500 pcs
4. The diameter of disc center hole is 13.0mm

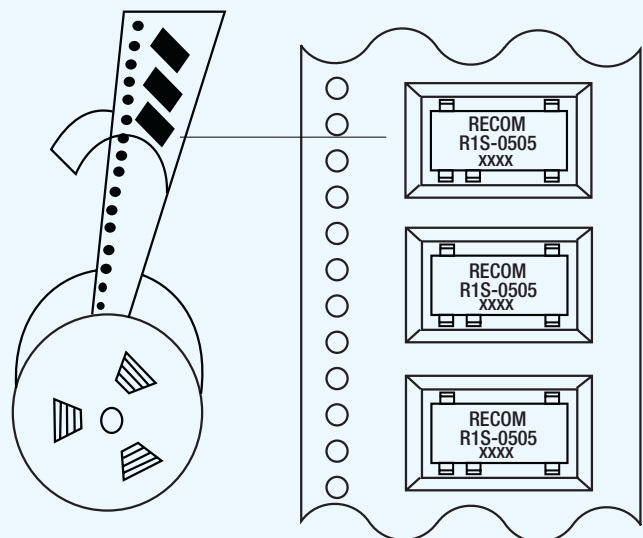

RSD(10)-xxxx, RSS12-xxxx, RSD12-xxxx, R1D(10)-xxxx, R1S12-xxxx, R1D12-xxxx,
& RZ-xxxx tape outline dimensions

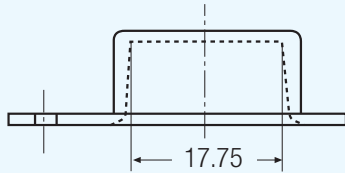

Sprocket hole $\varnothing 1.50+0.1/-0$
Sprocket hole tolerance over any 10 pitches ± 0.2

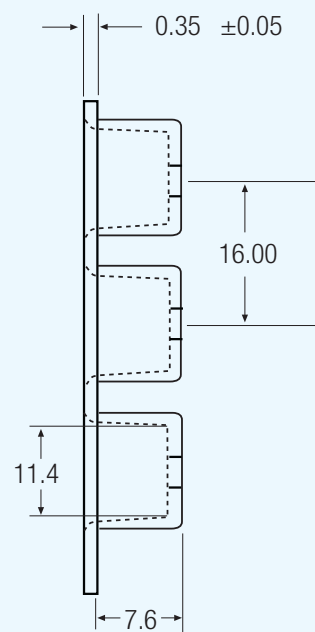
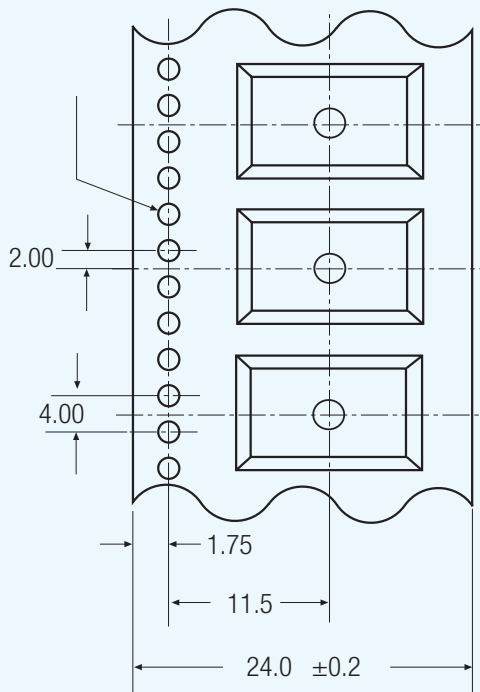

All dimensions in mm xx.xx ± 0.1

1. 10 sprocket hole pitch cumulative tolerance ± 0.20
2. All dimensions meet EIA-481-2 requirements
3. Component load per 13" reel : 500 pcs
4. The diameter of disc center hole is 13.0mm

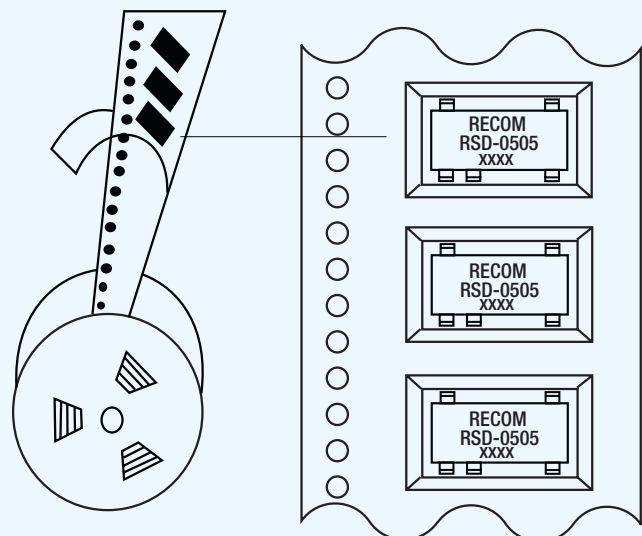

RSZ-xxxx, RTS-xxxx, R2S-xxxx, RTD-xxxx, R2D-xxxx
 R-78Axx-xxSMD & R-78AAxx-xxSMD tape outline dimensions

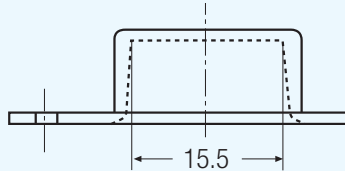

Sprocket hole $\varnothing 1.50 \pm 0.1 / -0$
 Sprocket hole tolerance over any 10 pitches ± 0.2

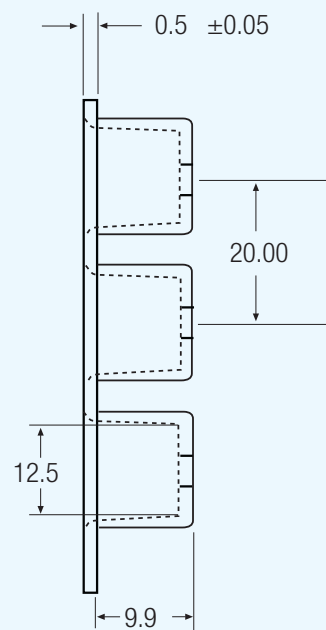
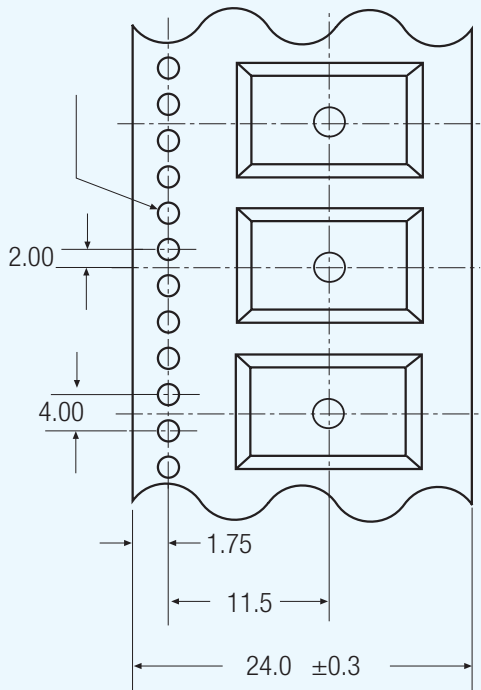

All dimensions in mm xx.xx ± 0.1

1. 10 sprocket hole pitch cumulative tolerance ± 0.20
2. All dimensions meet EIA-481-2 requirements
3. Component load per 13" reel : 500 pcs
4. The diameter of disc center hole is 13.0mm

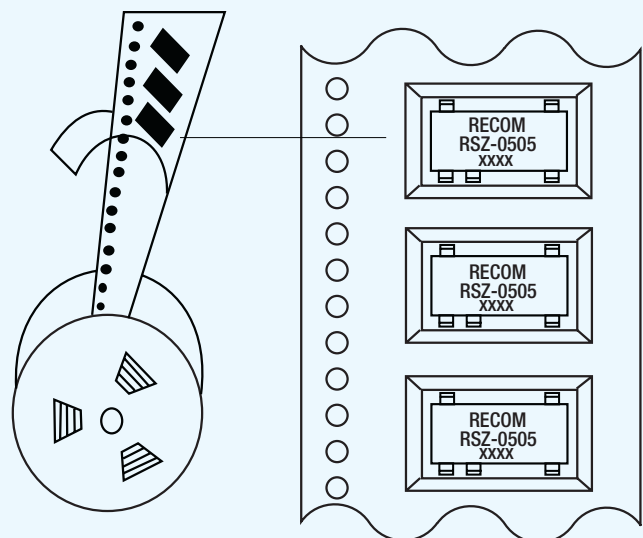



THINK GREEN - More than just a slogan.

THINK GREEN is a holistic concept to reduce energy consumption and waste at every stage of manufacture, use and disposal.



RECOM has developed a new series of DC-DC converters that are optimised to promote this THINK GREEN concept.



MANUFACTURE: The RECOM factory is certified to EN14001:2005 for its Environmental Management Systems. The aim of this standard is to reduce the environmental footprint of a business and to decrease the pollution and waste a business produces. For RECOM, this has meant reducing the demand on natural resources such as electricity and water used during production, introducing waste recycling throughout our production and investigating ways of reducing or eliminating hazardous-to-the-environment chemicals contained in the components used to build our converters.



DID YOU KNOW? - RECOM is already planning compliance with the new REACH (Reduction, Evaluation, Authorization and restriction of Chemicals) proposals – even though the requirements are not due to come into force until 2011!



USE: ICE (Innovation in Converter Excellence) Technology uses a combination of techniques to minimise internal heat dissipation and maximise the heat transfer to ambient to create a new converter series which offers high end performance at a price which is significantly lower than conventional specialist converters.

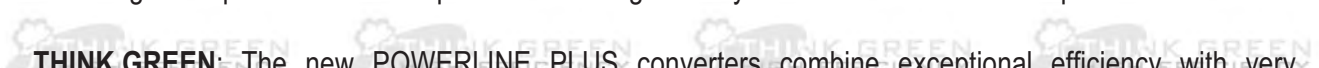

THINK GREEN: The new POWERLINE PLUS converters combine exceptional efficiency with very low standby currents - thus energy loss is reduced at both full load and under no load conditions. Similar low standby currents can also be found in our Innoline and Powerline AC-DC converters.

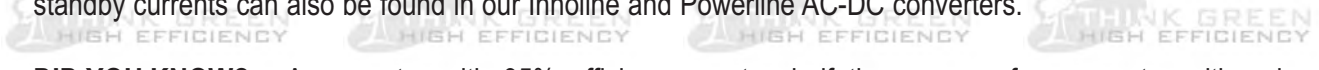

DID YOU KNOW? - A converter with 95% efficiency wastes half the energy of a converter with only 90% efficiency!



DISPOSAL: RECOM DC-DC and AC-DC converters are designed to give many years of service and offer a level of reliability that the competition find hard to match. Due to the complex construction of a converter, it is not possible to easily recycle a conventional module. RECOM has started to introduce open-frame designs without the uses of epoxy or metal cases. This makes the disposal of end-of-life converters easier as the converters can be ground up and any precious metals recovered by chemical means.

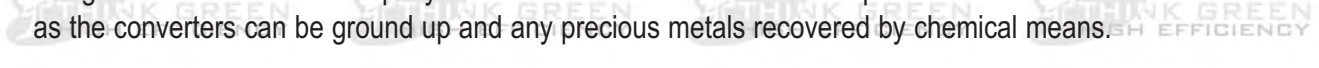

DID YOU KNOW? - We have converters still in active use that are more than 10 years old - and still going strong!



THE NEXT GENERATION **CONSTANT CURRENT HIGH POWER**

LED

All-in-one

DRIVER



- **Ready to use - Plug & Play**
- Up to 1.2A Constant Current
- PWM/Digital Dimming
- 100% linear **Analog Dimming**
- 96% Efficiency
- Wide Input Voltage Range
- Low Emissions (EN-55022)
- Long lifetime up to 600,000 hrs.
- Ultra Miniature Design
- High op. temperature/85°C

Fig. original size



NEW!
Wired version.



No more designing, certifying and procuring.

RECOM

RECOM ELECTRONIC - THE NETWORK



RECOM Asia Pte Ltd

Block 1003, Technopreneur Centre
Bukit Merah Central, # 04-30
159836 Singapore
Phone: (+65) 6276-8795
Fax: (+65) 6273-1477
Mobile: (+65) 9788-0774
enquiry@recomasia.com
www.recomasia.com

RECOM Asia Pte Ltd Shanghai Office

Rm 8205, 2F Building A,
Jiahua Business Center
No. 808 Hongqiao Rd
Shanghai, China
Phone: +86 (21) 6448-1990
Fax: +86 (21) 6448-0511
enquiry@recomasia.com
www.recomasia.com



RECOM ELECTRONIC GmbH

Otto-Hahn-Str. 60
D-63303 Dreieich
Germany
Phone: +49-(0)6103-30007-0
Fax: +49-(0)6103-30007-61
info@recom-electronic.com
www.recom-electronic.com

RECOM Application Engineering Support Center

Krottenseestraße 45,
A-4810 Gmunden
Phone: +43 (0) 7612-9003-3101
Fax: +43 (0) 7612-9003-3130
info@recom-development.at
www.recom-electronic.com



RECOM Power, Inc.

18 Bridge Street
Unit 4C
Brooklyn, NY 11201, USA
Phone: (+1) 718-855-9710
Fax: (+1) 718-855-9714
admin@recom-power.com
www.recom-power.com

Let us help you to find the right solution. Contact our Customer Service or find a Sales Representative.
With offices around the world, we are eager to help you meet your needs. Our highly trained sales staff and our technical engineers can help you find the right solution for your power application.

www.recom-electronic.com/contacts



RECOM ELECTRONIC uses ICE Technology. A combination of techniques to minimise internal heat dissipation and maximise the heat transfer to ambient to create a new converter series which offers high end performance at a price which is significantly lower than conventional specialist converters. RECOM - Green high-efficiency power solutions. **SAVE ENERGY. NOW.**

