

General Description

The MIC79050 is a simple single-cell lithium-ion battery charger. It includes an on-chip pass transistor for high precision charging. Featuring ultrahigh precision ($\pm 0.75\%$ over the Li-ion battery charging temperature range) and “zero” off mode current, the MIC79050 provides a very simple, cost effective solution for charging lithium-ion battery.

Other features of the MIC79050 include current limit and thermal shutdown protection. In the event the input voltage to the charger is disconnected, the MIC79050 also provides minimal reverse-current and reversed-battery protection.

The MIC79050 is a fixed 4.2V device and comes in the thermally-enhanced MSO-8, SO-8, and SOT-223 packages. The 8-pin versions also come equipped with enable and feedback inputs. All versions are specified over the temperature range of -40°C to $+125^{\circ}\text{C}$.

Features

- High accuracy charge voltage: $\pm 0.75\%$ over -5°C to $+60^{\circ}\text{C}$ (Li-ion charging temperature range)
- “Zero” off-mode current
- $10\mu\text{A}$ reverse leakage
- Ultralow 380mV dropout at 500mA
- Wide input voltage range
- Logic controlled enable input (8-pin devices only)
- Thermal shutdown and current limit protection
- Power MSOP-8, Power SOIC-8, and SOT-223
- Pulse charging capability

Applications

- Li-ion battery charger
- Cellular phones
- Palmtop computers
- PDAs
- Self charging battery packs

Ordering Information

Part Number		Voltage	Junction Temp. Range	Package
Standard	Pb-Free			
MIC79050-4.2BS	MIC79050-4.2YS	4.2V	-40°C to $+125^{\circ}\text{C}$	SOT-223-3
MIC79050-4.2BM	MIC79050-4.2YM	4.2V	-40°C to $+125^{\circ}\text{C}$	SOIC-8
MIC79050-4.2BMM	MIC79050-4.2YMM	4.2V	-40°C to $+125^{\circ}\text{C}$	MSOP-8

Typical Applications

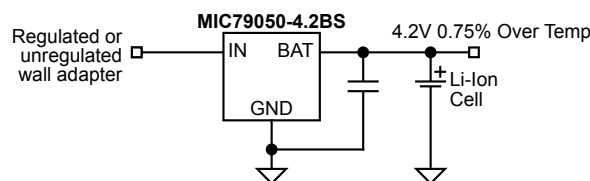

Simplest Battery Charging Solution

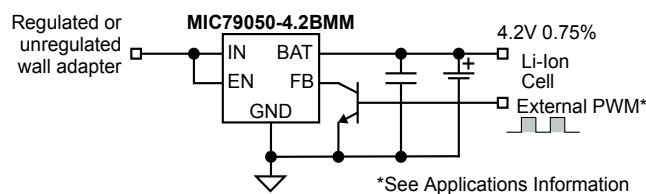

Pulse-Charging Application

Pin Configuration

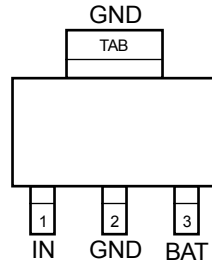

MIC79050-x.xBS/YS
SOT-223

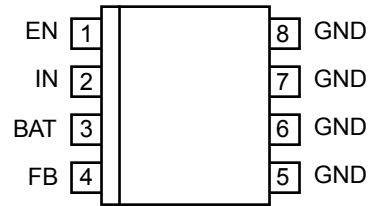

MIC79050-x.xBM/YM
SOIC-8 and MSOP-8

Pin Description

Pin No. SOT-223	Pin No. SOIC-8 MSOP-8	Pin Name	Pin Function
1	2	IN	Supply Input
2, TAB	5-8	GND	Ground: SOT-223 pin 2 and TAB are internally connected. SO-8 pins 5 through 8 are internally connected.
3	3	BAT	Battery Voltage Output
	1	EN	Enable (Input): TTL/CMOS compatible control input. Logic high = enable; logic low or open = shutdown.
	4	FB	Feedback Node

Absolute Maximum Ratings (Note 1)

Supply Input Voltage (V_{IN}).....	-20V to +20V
Power Dissipation (P_D).....	Internally Limited, Note 3
Junction Temperature (T_J).....	-40°C to +125°C
Lead Temperature (soldering, 5 sec.).....	260°C
Storage Temperature (T_S).....	-65°C to +150°C

Operating Ratings (Note 2)

Supply Input Voltage (V_{IN}).....	+2.5V to +16V
Enable Input Voltage (V_{EN}).....	0V to V_{IN}
Junction Temperature (T_J).....	-40°C to +125°C
Package Thermal Resistance (Note 3).....	
MSOP-8 (θ_{JA}).....	80°C/W
SOIC-8(θ_{JA}).....	63°C/W
SOT-223(θ_{JC}).....	15°C/W

Electrical Characteristics

$V_{IN} = V_{BAT} + 1.0V$; $C_{OUT} = 4.7\mu F$, $I_{OUT} = 100\mu A$; $T_J = 25^\circ C$, **bold** values indicate $-40^\circ C \leq T_J \leq +125^\circ C$; unless noted.

Symbol	Parameter	Conditions	Min	Typical	Max	Units
V_{BAT}	Battery Voltage Accuracy	variation from nominal V_{OUT} -5°C to +60°C	-0.75		+0.75	%
$\Delta V_{BAT}/\Delta T$ ppm/°C	Battery Voltage Temperature Coefficient	Note 4		40		
$\Delta V_{BAT}/V_{BAT}$	Line Regulation	$V_{IN} = V_{BAT} + 1V$ to 16V		0.009	0.05 0.1	%/V %/V
$\Delta V_{BAT}/V_{BAT}$	Load Regulation	$I_{OUT} = 100\mu A$ to 500mA, Note 5		0.05	0.5 0.7	% %
$V_{IN} - V_{BAT}$	Dropout Voltage, Note 6	$I_{OUT} = 500mA$		380	500 600	mV mV
I_{GND}	Ground Pin Current, Notes 7, 8	$V_{EN} \geq 3.0V$, $I_{OUT} = 100\mu A$		85	130 170	μA μA
		$V_{EN} \geq 3.0V$, $I_{OUT} = 500mA$		11	20 25	mA mA
I_{GND}	Ground Pin Quiescent Current, Note 8	$V_{EN} \leq 0.4V$ (shutdown)		0.05	3	μA
		$V_{EN} \leq 0.18V$ (shutdown)		0.10	8	μA
PSRR	Ripple Rejection	f = 120Hz		75		dB
I_{LIMIT}	Current Limit	$V_{BAT} = 0V$		750	900 1000	mA mA
$\Delta V_{BAT}/\Delta P_D$	Thermal Regulation	Note 9		0.05		%/W

ENABLE Input

V_{ENL}	Enable Input Logic-Low Voltage	$V_{EN} = \text{logic low (shutdown)}$		0.4	0.18	V V
		$V_{EN} = \text{logic high (enabled)}$	2.0			V
I_{ENL}	Enable Input Current	$V_{ENL} \leq 0.4V$ (shutdown)		0.01	-1	μA
		$V_{ENL} \leq 0.18V$ (shutdown)		0.01	-2	μA
I_{ENH}		$V_{ENH} \geq 2.0V$ (enabled)		5	20 25	μA μA

Note 1. Exceeding the absolute maximum rating may damage the device.

Note 2. The device is not guaranteed to function outside its operating rating.

Note 3. The maximum allowable power dissipation at any T_A (ambient temperature) is calculated using: $P_{D(max)} = (T_{J(max)} - T_A) \div \theta_{JA}$. Exceeding the maximum allowable power dissipation will result in excessive die temperature, and the regulator will go into thermal shutdown.

Note 4. Battery voltage temperature coefficient is the worst case voltage change divided by the total temperature range.

Note 5. Regulation is measured at constant junction temperature using low duty cycle pulse testing. Parts are tested for load regulation in the load range from 100 μA to 500mA. Changes in output voltage due to heating effects are covered by the thermal regulation specification.

Note 6. Dropout voltage is defined as the input to battery output differential at which the battery voltage drops 2% below its nominal value measured at 1V differential.

Note 7: Ground pin current is the charger quiescent current plus pass transistor base current. The total current drawn from the supply is the sum of the load current plus the ground pin current.

Note 8: V_{EN} is the voltage externally applied to devices with the EN (enable) input pin. [MSO-8(MM) and SO-8 (M) packages only.]

Note 9: Thermal regulation is the change in battery voltage at a time "t" after a change in power dissipation is applied, excluding load or line regulation effects. Specifications are for a 500mA load pulse at $V_{IN} = 16V$ for $t = 10ms$.

Typical Characteristics

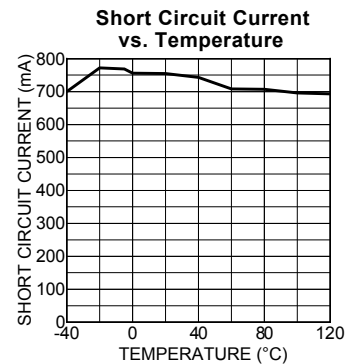
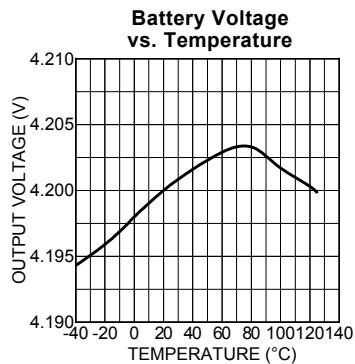
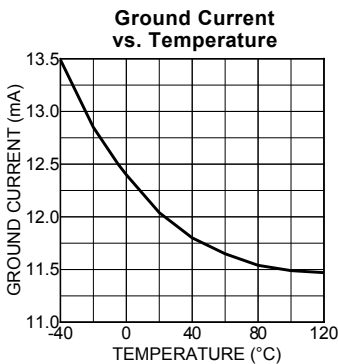
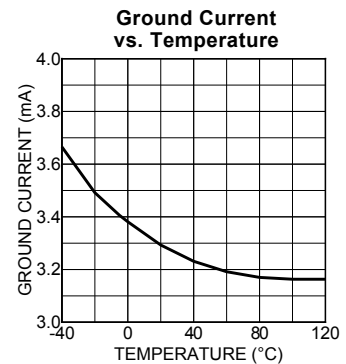
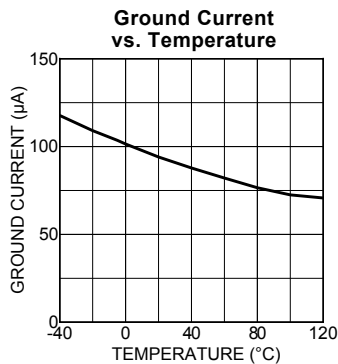
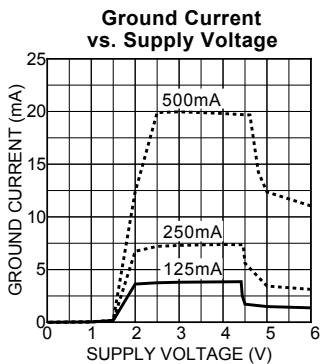
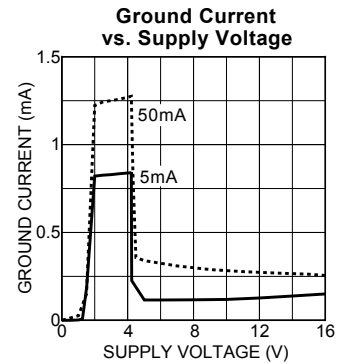
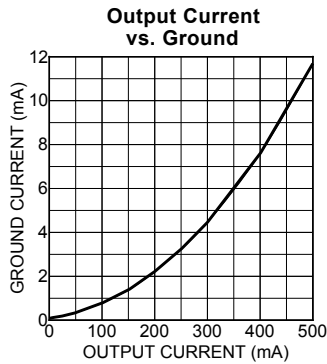
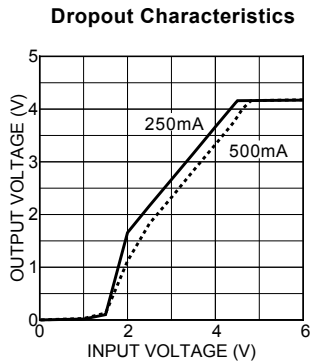
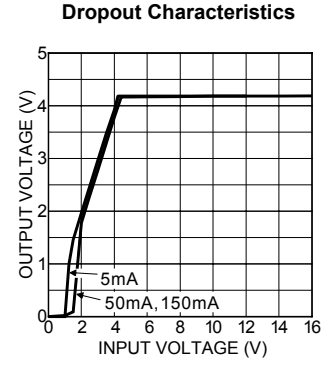
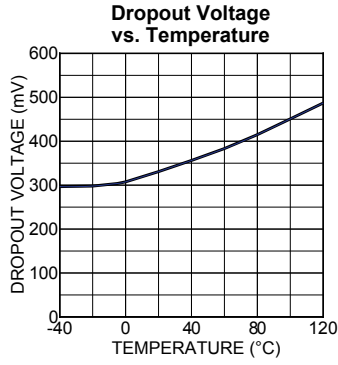
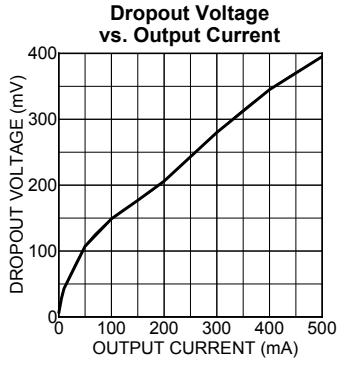

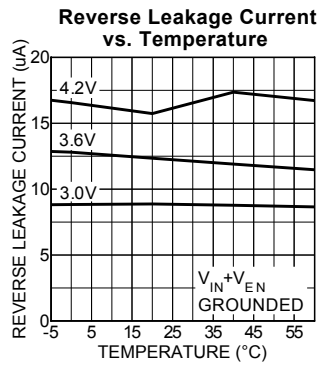
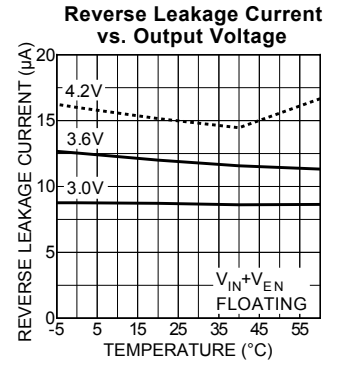
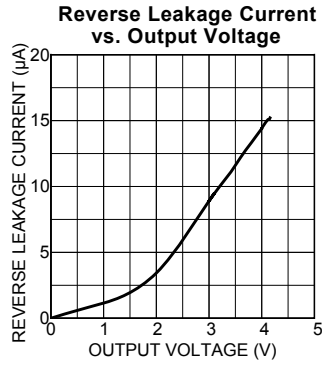
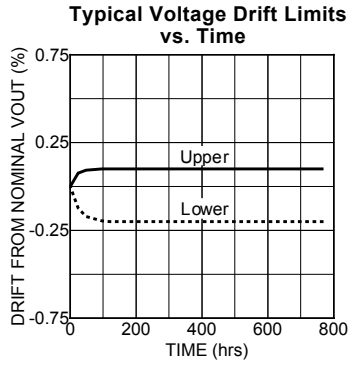

Block Diagrams

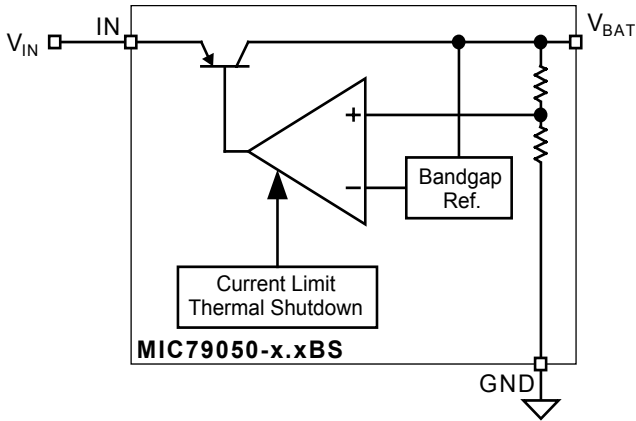

3-Pin Version

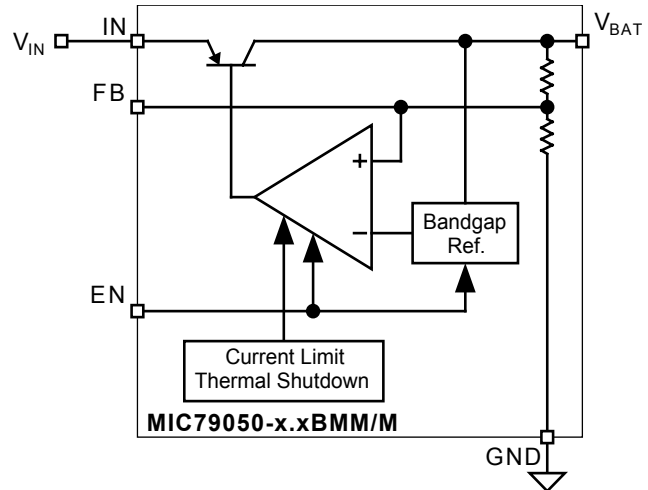

5-Pin Version

Functional Description

The MIC79050 is a high-accuracy, linear battery charging circuit designed for the simplest implementation of a single lithium-ion (Li-ion) battery charger. The part can operate from a regulated or unregulated power source, making it ideal for various applications. The MIC79050 can take an unregulated voltage source and provide an extremely accurate termination voltage. The output voltage varies only 0.75% from nominal over the standard temperature range for Li-ion battery charging (-5°C to 60°C). With a minimum of external components, an accurate constant current charger can be designed to provide constant current, constant voltage charging for Li-ion cells.

Input Voltage

The MIC79050 can operate with an input voltage up to 16V (20V absolute maximum), ideal for applications where the input voltage can float high, such as an unregulated wall adapter that obeys a load-line. Higher voltages can be sustained without any performance degradation to the output voltage. The line regulation of the device is typically $0.009\%/V$; that is, a 10V change on the input voltage corresponds to a 0.09% change in output voltage.

Enable

The MIC79050 has an enable pin that allows the charger to be disabled when the battery is fully charged and the current

drawn by the battery has approached a minimum and/or the maximum charging time has timed out. When disabled, the regulator output sinks a minimum of current with the battery voltage applied directly onto the output. This current is typically $12\mu\text{A}$ or less.

Feedback

The feedback pin allows for external manipulation of the control loop. This node is connected to an external resistive divider network, which is connected to the internal error amplifier. This amplifier compares the voltage at the feedback pin to an internal voltage reference. The loop then corrects for changes in load current or input voltage by monitoring the output voltage and linearly controlling the drive to the large, PNP pass element. By externally controlling the voltage at the feedback pin the output can be disabled or forced to the input voltage. Pulling and holding the feedback pin low forces the output low. Holding the feedback pin high forces the pass element into saturation, where the output will be the input minus the saturation (dropout) voltage.

Battery Output

The BAT pin is the output of the MIC79050 and connects directly to the cell to provide charging current and voltage. When the input is left floating or grounded, the BAT pin limits reverse current to $\leq 12\mu\text{A}$ to minimize battery drain.

Applications Information

Simple Lithium-Ion Battery Charger.

Figure 1A shows a simple, complete lithium-ion battery charger. The charging circuit comprises of a cheap wall adapter, with a load-line characteristic. This characteristic is always present with cheap adapters due to the internal impedance of the transformer windings. The load-line of the unregulated output should be < 4.4V to 4.6V at somewhere between 0.5C to 1C of the battery under charge. This 4.4 to 4.6V value is an approximate number based on the headroom needed above 4.2V for the MIC79050 to operate correctly e.g. For

a 500mAh battery, the output of the semi-regulated supply should be between 225mA to 500mA (0.5C to 1C). If it is below 225mA no damage will occur but the battery will take longer to charge. Figure 1B shows a typical wall adapter characteristic with an output current of 350mA at 4.5V. This natural impedance of the wall adapter will limit the max current into the battery, so no external circuitry is needed to accomplish this.

If extra impedance is needed to achieve the desired load-line, extra resistance can easily be added in series with the MIC79050 IN pin.

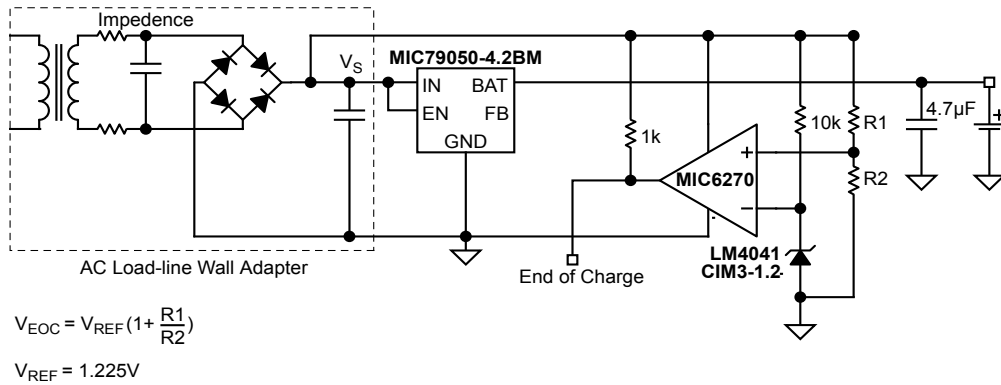

Figure 1A. Load-Line Charger With End-Of-Charge Termination Circuit.

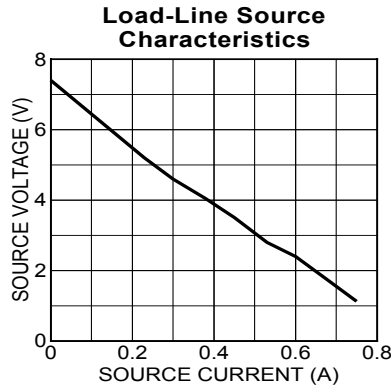

Figure 1B. Load-Line Characteristics of AC Wall Adapter

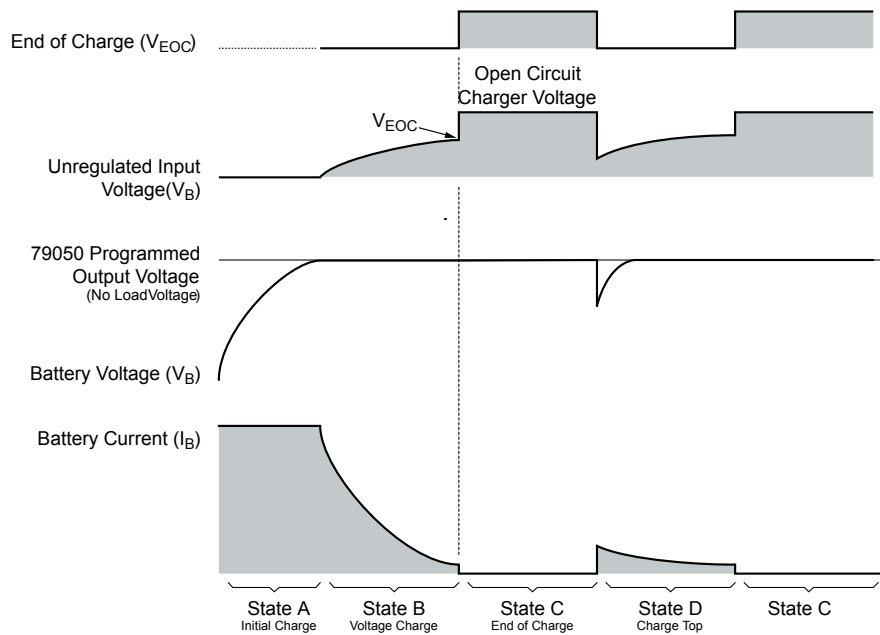

Figure 1C. Charging Cycles

The Charging Cycle (See Figure 1C.)

1. State A: Initial charge. Here the battery’s charging current is limited by the wall adapter’s natural impedance. The battery voltage approaches 4.2V.
2. State B: Constant voltage charge. Here the battery voltage is at $4.2V \pm 0.75\%$ and the current is decaying in the battery. When the battery has reached approximately 1/10th of its 1C rating, the battery is considered to have reached full charge. Because of the natural characteristic impedance of the cheap wall adapters, as the battery voltage decreases so the input voltage increases. The MIC6270 and the LM4041 are configured as a simple voltage monitor, indicating when the input

3. State C: End of charge cycle. When the input voltage, V_S reaches V_{EOC} , an end of charge signal is indicated.
4. State D: Top up charge. As soon as enough current is drawn out of the input source, which pulls the voltage lower than the V_{EOC} , the end of charge flag will be pulled low and charging will initiate.

Variations on this scheme can be implemented, such as the circuit shown in Figure 2.

For those designs that have a zero impedance source, see Figure 3.

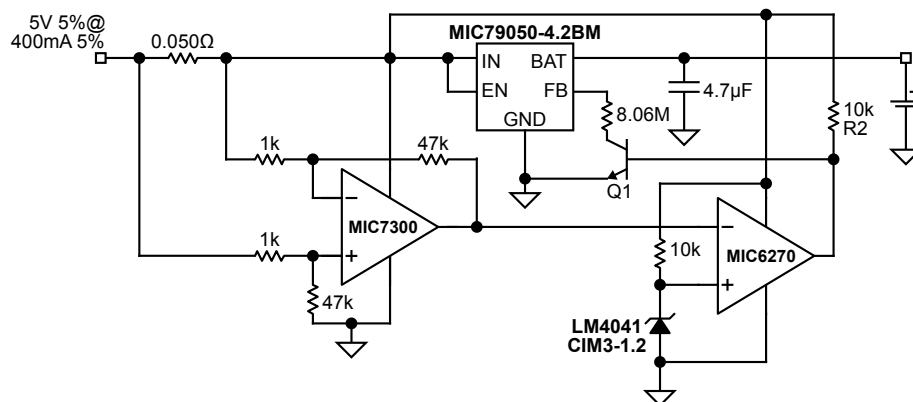

Figure 2. Protected Constant-Current Charger

Protected Constant-Current Charger

Another form of charging is using a simple wall adapter that offers a fixed voltage at a controlled, maximum current rating. The output of a typical charger will source a fixed voltage at a maximum current unless that maximum current is exceeded. In the event that the maximum current is exceeded, the voltage will drop while maintaining that maximum current. Using an MIC79050 after this type of charger is ideal for lithium-ion battery charging. The only obstacle is end of charger termination. Using a simple differential amplifier and a similar comparator and reference circuit, similar to Figure 1, completes a single cell lithium-ion battery charger solution.

Figure 2 shows this solution in completion. The source is a fixed 5V source capable of a maximum of 400mA of current. When the battery demands full current (fast charge), the source will provide only 400mA and the input will be pulled down. The output of the MIC79050 will follow the input minus a small voltage drop. When the battery approaches full charge, the current will taper off. As the current across R_S approaches 50mA, the output of the differential amplifier (MIC7300) will approach 1.225V, the reference voltage set by the LM4041. When it drops below the reference voltage, the output of the comparator (MIC6270) will allow the base of Q1 to be pulled high through R2.

Zero-Output Impedance Source Charging

Input voltage sources that have very low output impedances can be a challenge due to the nature of the source. Using the circuit in Figure 3 will provide a constant-current and constant voltage charging algorithm with the appropriate end-of-charge termination. The main loop consists of an op-amp controlling the feedback pin through the schottky diode, D1. The charge current through R_S is held constant by the op-amp circuit until the output draws less than the set charge-current. At this point, the output goes constant-voltage. When the current through R_S gets to less than 50mA, the difference amp output becomes less than the reference voltage of the MIC834 and the output pulls low. This sets the output of the MIC79050 less than nominal, stopping current flow and terminating charge.

Lithium-Ion Battery Charging

Single lithium-ion cells are typically charged by providing a constant current and terminating the charge with constant voltage. The charge cycle must be initiated by ensuring that the battery is not in deep discharge. If the battery voltage is below 2.5V, it is commonly recommended to trickle charge the battery with 5mA to 10mA of current until the output is above 2.5V. At this point the battery can be charged with constant current until it reaches its top off voltage (4.2V for a typical single lithium-ion cell) or a time out occurs.

For the constant-voltage portion of the charging circuit, an extremely accurate termination voltage is highly recommended. The higher the accuracy of the termination circuit, the more energy the battery will store. Since lithium-ion cells do not exhibit a memory effect, less accurate termination does not harm the cell but simply stores less usable energy in the battery. The charge cycle is completed by disabling the charge circuit after the termination current drops below a minimum recommended level, typically 50mA or less, depending on the manufacturer's recommendation, or if the circuit times out.

Time Out

The time-out aspect of lithium-ion battery charging can be added as a safety feature of the circuit. Often times this function is incorporated in the software portion of an application using a real-time clock to count out the maximum amount of time allowed in the charging cycle. When the maximum recommended charge time for the specific cell has been exceeded, the enable pin of the MIC79050 can be pulled low, and the output will float to the battery voltage, no longer providing current to the output.

As a second option, the feedback pin of the MIC79050 can be modulated as in Figure 4. Figure 4. shows a simple circuit where the MIC834, an integrated comparator and reference, monitors the battery voltage and disables the MIC79050 output after the voltage on the battery exceeds a set value. When the voltage decays below this set threshold, the MIC834 drives Q1 low allowing the MIC79050 to turn on again and provide current to the battery until it is fully charged. This form of pulse charging is an acceptable way of maintaining the full charge on a cell until it is ready to be used.

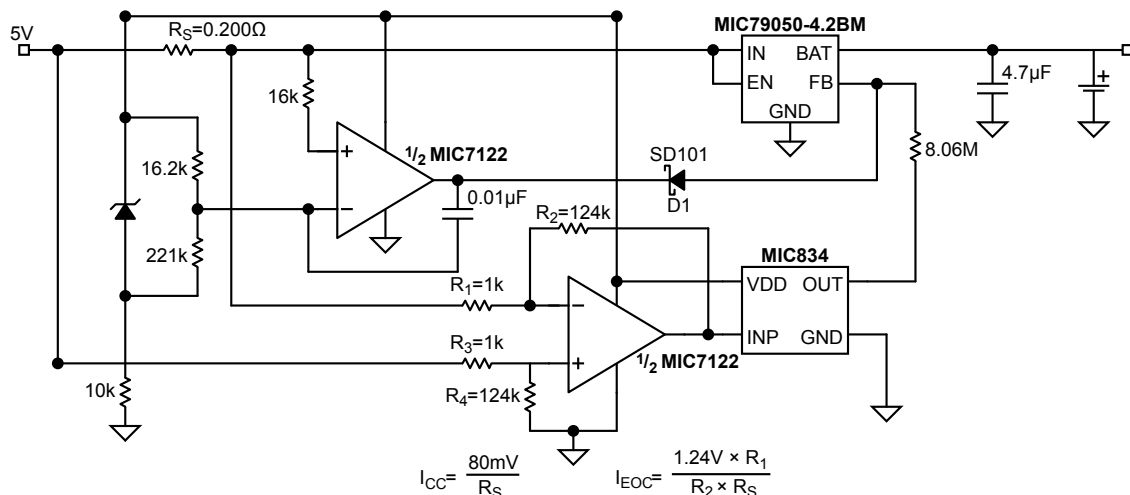

Figure 3.

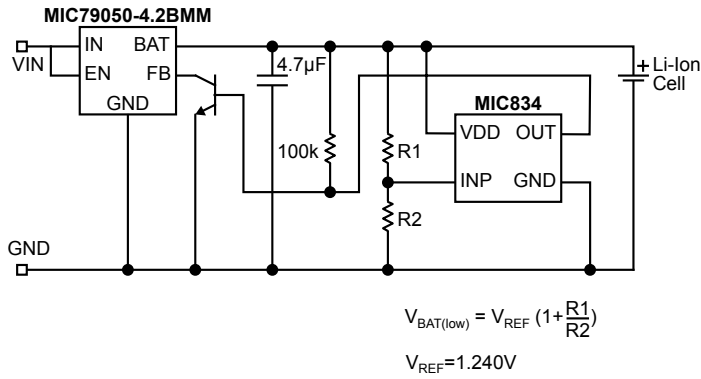

Figure 4. Pulse Charging For Top-off Voltage

Charging Rate

Lithium-ion cells are typically charged at rates that are fractional multiples of their rated capacity. The maximum varies between 1C – 1.3C (1× to 1.3× the capacity of the cell). The MIC79050 can be used for any cell size. The size of the cell and the current capability of the input source will determine the overall circuit charge rate. For example, a 1200mAh battery charged with the MIC79050 can be charged at a maximum of 0.5C. There is no adverse effects to charging at lower charge rates; that charging will just take longer. Charging at rates greater than 1C are not recommended, or do they decrease the charge time linearly.

The MIC79050 is capable of providing 500mA of current at its nominal rated output voltage of 4.2V. If the input is brought below the nominal output voltage, the output will follow the input, less the saturation voltage drop of the pass element. If the cell draws more than the maximum output current of the device, the output will be pulled low, charging the cell at 600mA to 700mA current. If the input is a fixed source with a low output impedance, this could lead to a large drop across the MIC79050 and excess heating. By driving the feedback pin with an external PWM-circuit, the MIC79050 can be used to pulse charge the battery to reduce power dissipation and bring the device and the entire unit down to a lower operating temperature. Figure 5 shows a typical configuration for a PWM-based pulse-charging topology. Two circuits are shown in Figure 5: circuit a uses an external PWM signal to control the charger, while circuit b uses the MIC4417 as a low duty-cycle oscillator to drive the base of Q1. (Consult the battery manufacturer for optimal pulse-charging techniques).

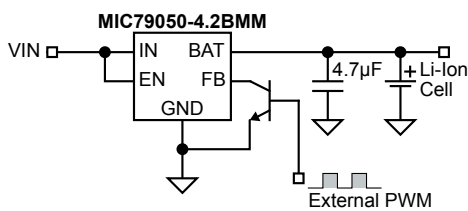

Figure 5A.

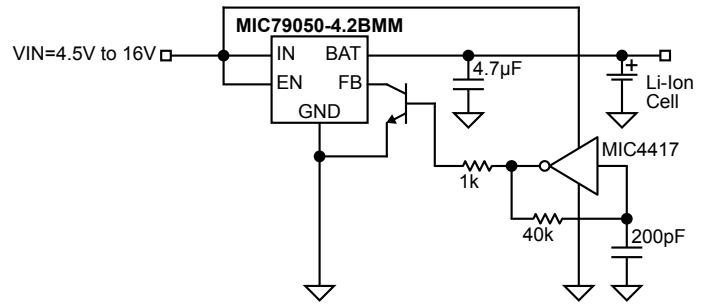

Figure 5B. PWM Based Pulse-charging Applications

Figure 6 shows another application to increase the output current capability of the MIC79050. By adding an external PNP power transistor, higher output current can be obtained while maintaining the same accuracy. The internal PNP now becomes the driver of a darlington array of PNP transistors, obtaining much higher output currents for applications where the charge rate of the battery is much higher.

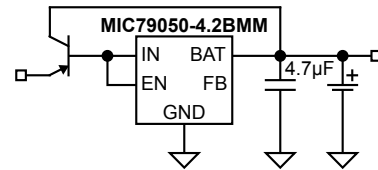

Figure 6. High Current Charging

Regulated Input Source Charging

When providing a constant-current, constant-voltage, charger solution from a well-regulated adapter circuit, the MIC79050 can be used with external components to provide a constant voltage, constant-current charger solution. Figure 7 shows a configuration for a high-side battery charger circuit that monitors input current to the battery and allows a constant current charge that is accurately terminated with the MIC79050. The circuit works best with smaller batteries, charging at C rates in the 300mA to 500mA range. The MIC7300 op-amp compares the drop across a current sense resistor and compares that to a high-side voltage reference, the LM4041, pulling the feedback pin low when the circuit is in the constant-current mode. When the current through the resistor drops and the battery gets closer to full charge, the output of the op-amp rises and allows the internal feedback network of the regulator take over, regulating the output to 4.2V.

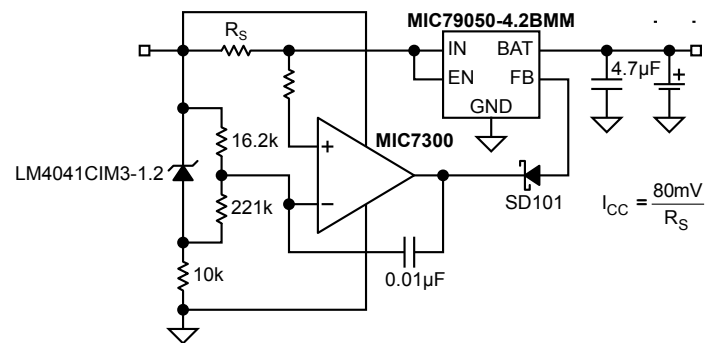

Figure 7. Constant Current, Constant Voltage Charger

Simple Charging

The MIC79050 is available in a three-terminal package, allowing for extremely simple battery charging. When used with a current-limited, low-power input supply, the MIC79050-4.2BS completes a very simple, low-charge-rate, battery-charger circuit. It provides the accuracy required for termination, while a current-limited input supply offers the constant-current portion of the algorithm.

Thermal Considerations

The MIC79050 is offered in three packages for the various applications. The SOT-223 is most thermally efficient of the three packages, with the power SOIC-8 and the power MSOP-8 following suit.

Power SOIC-8 Thermal Characteristics

One of the secrets of the MIC79050's performance is its power SO-8 package featuring half the thermal resistance of a standard SO-8 package. Lower thermal resistance means more output current or higher input voltage for a given package size.

Lower thermal resistance is achieved by joining the four ground leads with the die attach paddle to create a single-piece electrical and thermal conductor. This concept has been used by MOSFET manufacturers for years, proving very reliable and cost effective for the user.

Thermal resistance consists of two main elements, θ_{JC} , or thermal resistance junction to case and θ_{CA} , thermal resistance case to ambient (Figure 8). θ_{JC} is the resistance from the die to the leads of the package. θ_{CA} is the resistance from the leads to the ambient air and it includes θ_{CS} , thermal resistance case to sink, and θ_{SA} , thermal resistance sink to ambient. Using the power SOIC-8 reduces the θ_{JC} dramatically and allows the user to reduce θ_{CA} . The total thermal resistance, θ_{JA} , junction to ambient thermal resistance, is the limiting factor in calculating the maximum power dissipation capability of the device. Typically, the power SOIC-8 has a θ_{JC} of 20°C/W, this is significantly lower than the standard SOIC-8 which is typically 75°C/W. θ_{CA} is reduced because pins 5-8 can now be soldered directly to a ground plane, which significantly reduces the case to sink thermal resistance and sink to ambient thermal resistance.

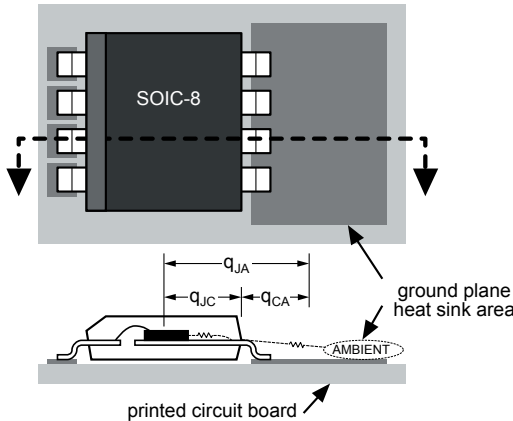

Figure 8. Thermal Resistance

The MIC79050 is rated to a maximum junction temperature of 125°C. It is important not to exceed this maximum junction temperature during operation of the device. To prevent this maximum junction temperature from being exceeded, the appropriate ground plane heat sink must be used.

Figure 9 shows curves of copper area versus power dissipation, each trace corresponding to different temperature rises above ambient. From these curves, the minimum area of copper necessary for the part to operate safely can be determined. The maximum allowable temperature rise must be calculated to determine operation along which curve.

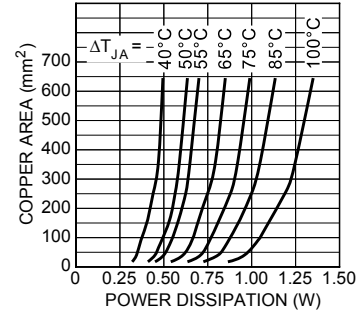

Figure 9. Copper Area vs. Power-SOIC Power Dissipation (ΔT_{JA})

Where $\Delta T = T_{j(max)} - T_{a(max)}$

$T_{j(max)} = 125^\circ\text{C}$

$T_{a(max)}$ = maximum ambient operating temperature

For example, the maximum ambient temperature is 40°C, the ΔT is determined as follows:

$$\Delta T = +125^\circ\text{C} - 40^\circ\text{C}$$

$$\Delta T = +85^\circ\text{C}$$

Using Figure 9, the minimum amount of required copper can be determined based on the required power dissipation. Power dissipation in a linear regulator is calculated as follows:

$$P_D = (V_{in} - V_{out}) \cdot I_{out} + V_{in} \cdot I_{qnd}$$

For example, using the charging circuit in Figure 7, assume the input is a fixed 5V and the output is pulled down to 4.2V at a charge current of 500mA. The power dissipation in the MIC79050 is calculated as follows:

$$P_D = (5V - 4.2V) \cdot 0.5A + 5V \cdot 0.012A$$

$$P_D = 0.460W$$

From Figure 9, the minimum amount of copper required to operate this application at a ΔT of 85C is less than 50mm².

Quick Method

Determine the power dissipation requirements for the design along with the maximum ambient temperature at which the device will be operated. Refer to Figure 10, which shows safe operating curves for 3 different ambient temperatures: +25°C, +50°C and +85°C. From these curves, the minimum amount of copper can be determined by knowing the maximum power dissipation required. If the maximum ambient

temperature is +40°C and the power dissipation is as above, 0.46W, the curve in Figure 10 shows that the required area of copper is 50mm².

The θ_{JA} of this package is ideally 63°C/W, but it will vary depending upon the availability of copper ground plane to which it is attached.

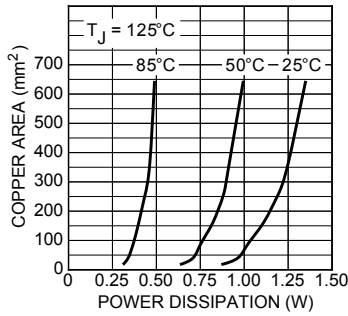

Figure 10. Copper Area vs. Power-SOIC Power Dissipation (T_A)

Power MSOP-8 Thermal Characteristics

The power-MSOP-8 package follows the same idea as the power-SO-8 package, using four ground leads with the die attach paddle to create a single-piece electrical and thermal conductor, reducing thermal resistance and increasing power dissipation capability.

The same method of determining the heat sink area used for the power-SOIC-8 can be applied directly to the power-MSOP-8. The same two curves showing power dissipation versus copper area are reproduced for the power-MSOP-8 and they can be applied identically.

Quick Method

Determine the power dissipation requirements for the design along with the maximum ambient temperature at which the device will be operated. Refer to Figure 12, which shows safe operating curves for 3 different ambient temperatures, +25°C, +50°C and +85°C. From these curves, the minimum amount of copper can be determined by knowing the maximum power dissipation required. If the maximum ambient temperature is +25°C and the power dissipation is 1W, the curve in Figure 12v shows that the required area of copper is 500mm², when using the power MSOP-8

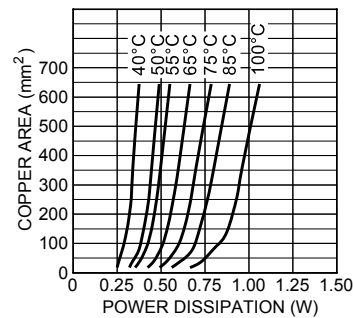

Figure 11. Copper Area vs. Power-MSOP Power Dissipation (ΔT_{JA})

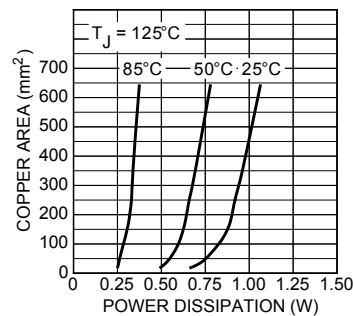
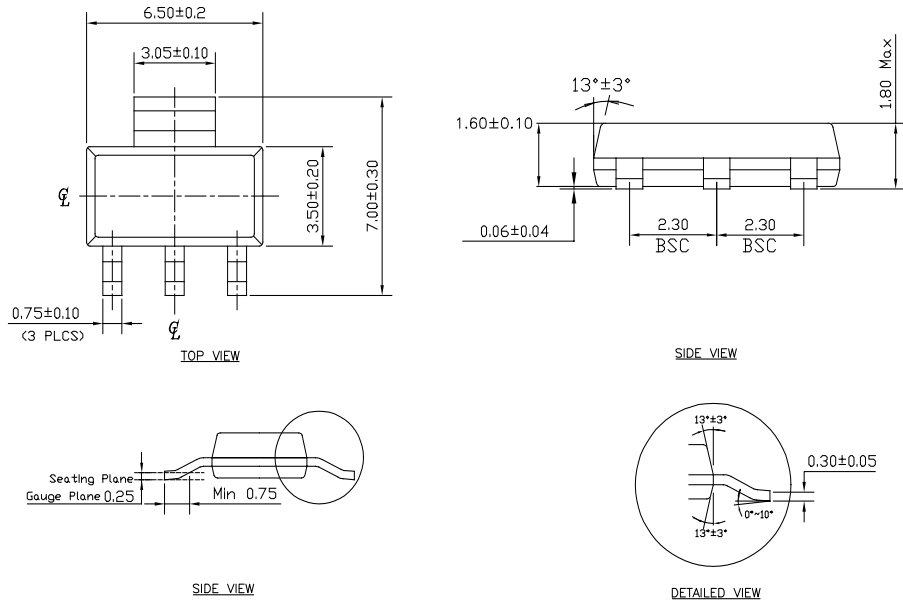

Figure 12. Copper Area vs. Power-MSOP Power Dissipation (T_A)

Package Information



NOTE:

1. Dimensions and tolerances are as per ANSI Y14.6M, 1982.
2. Controlling dimension: Millimeters.
3. Dimensions are exclusive of mold flash and gate burr.
4. All specification comply to Jeduc spec T0261 Issue C.

SOT-223 (S)

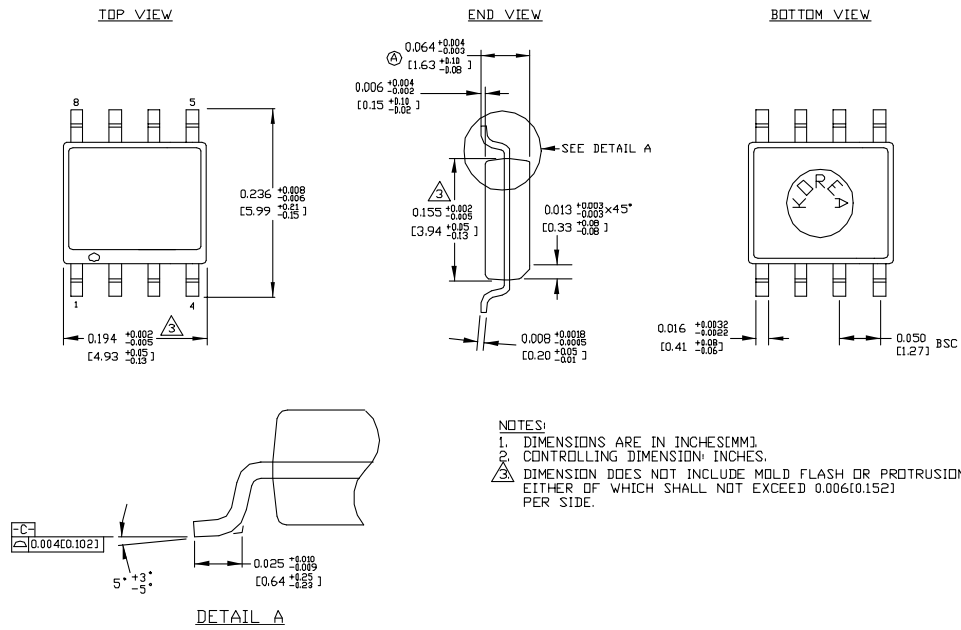

8-Pin SOIC (M)

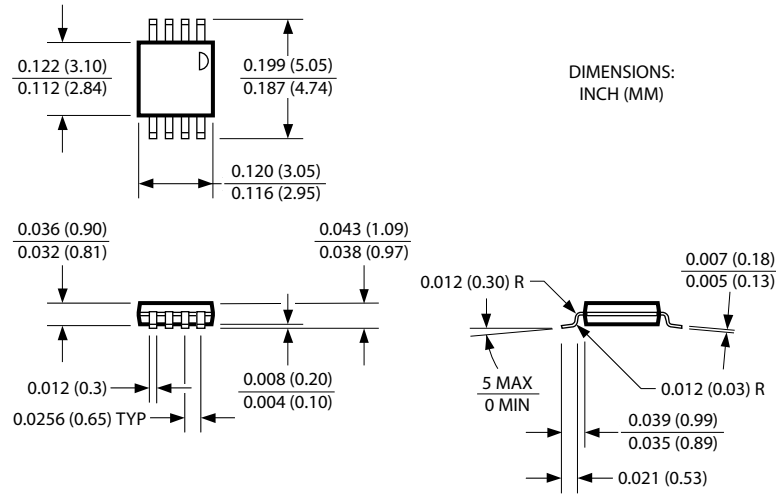

8-Pin MSOP (MM)

MICREL INC. 2180 FORTUNE DRIVE SAN JOSE, CA 95131 USA

TEL + 1 (408) 944-0800 FAX + 1 (408) 474-1000 WEB <http://www.micrel.com>

This information furnished by Micrel in this data sheet is believed to be accurate and reliable. However no responsibility is assumed by Micrel for its use. Micrel reserves the right to change circuitry and specifications at any time without notification to the customer.

Micrel Products are not designed or authorized for use as components in life support appliances, devices or systems where malfunction of a product can reasonably be expected to result in personal injury. Life support devices or systems are devices or systems that (a) are intended for surgical implant into the body or (b) support or sustain life, and whose failure to perform can be reasonably expected to result in a significant injury to the user. A Purchaser's use or sale of Micrel Products for use in life support appliances, devices or systems is a Purchaser's own risk and Purchaser agrees to fully indemnify Micrel for any damages resulting from such use or sale.

© 2000 Micrel, Inc.