

No OF POSITIONS
 -020, -040, -060,
 *-080, *-100
 (PER ROW)
 *(SEE NOTE 11)

OPTION

- A: ALIGNMENT PINS
- LC: LOCKING CLIPS (SEE NOTE 12)
(USE LC-08-TM-01)
- K: POLYIMIDE FILM
(USE K-DOT-.276-.375-.005, SEE FIG. 2)
(N/A ON STYLE -07 & -08)
- TR: TAPE & REEL (60 POS. MAX)
(40 FOR -GP OPTION)
- (N/A ON STYLE -05, -06, -07, & -08)
- GP: GUIDE POSTS (SEE FIG. 3, SHT. 2)
(AVAILABLE ON -01 ONLY)
(USE QTE-20-01-D-XX-GP)
(T & R PACK: 40 POS. MAX.)
- SD: SCREW DOWN (SEE FIGURE 4, SHEET 2)
(AVAILABLE ON -01 ONLY)
(USE QTE-20-01-D-XX-SD)
- FL: FRICTION LOCKS (SEE FIG. 8, SHEET 4)
(ONLY AVAILABLE ON -01 & -02)
(NOT AVAILABLE WITH -GP, -SD)
- RT1: RETENTION OPTION (SEE FIG. 9, SHEET 5)
(ONLY AVAILABLE ON -01 LEAD STYLE)
(MUST USE -A OPTION)
(USE QTE-20-01-D-XX-A-RT1 & T-1R36-01-F)
(NOT AVAILABLE WITH -LC, -GP, -SD, OR -FL)
- L: LATCHING OPTION (40 POS. MAX.)
(SEE FIG. 11, SHEET 6) (MUST USE -A OPTION)
(AVAILABLE ON -01 ONLY)
(NOT AVAILABLE WITH -LC, -GP, -SD, -FL,
OR -RT1)

LEAD STYLE

- 01: .1680 [4.267]
- 02: .2861 [7.267]
- 03: .4042 [10.267]
- 04: .6010 [15.265]
- 05: .7190 [18.263]
- 06: .8370 [21.260]
- 07: .9540 [24.231]
- 08: 1.1510 [29.260]
- 09: .5220 [13.258]
- 10: .5606 [14.239]

PLATING SPECIFICATION

- F: FLASH GOLD WITH MATTE TIN TAILS
(USE T-1SXX-XX-F, T-1G1-XX-F)
(SEE NOTE 07)
- L: LIGHT GOLD WITH MATTE TIN TAILS
(USE T-1SXX-XX-L, T-1G1-XX-L)
- H: HEAVY GOLD WITH FLASH GOLD TAILS
(USE T-1SXX-XX-H, T-1G1-XX-G)
- C: ELECTRO-POLISHED SELECTIVE
(USE T-1SXX-XX-C, T-1G1-XX-L)
- STL: SELECTIVE TIN LEAD
(USE T-1SXX-XX-STL, T-1G1-XX-STL)
- FTL: SELECTIVE TIN LEAD
(USE T-1SXX-XX-FTL, T-1G1-XX-FTL)

ROW SPECIFICATION

- D: DOUBLE (USE QTE-20-XX-D-XX
& QTEH-20-XX-D-XX)

No OF BANKS

T-1SXX-XX-XXX
(SEE TABLE 1)

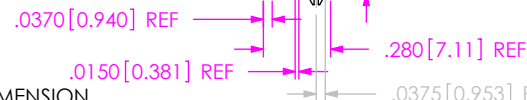

SECTION "A"-"A"

NOTES:

1. $\text{\textcircled{C}}$ REPRESENTS A CRITICAL DIMENSION.
2. MINIMUM TERMINAL RETENTION: 8 OZ.
3. MINIMUM GROUND PLANE RETENTION: 1 LB.
4. PARTS TO BE MOLDED TO POSITION.
5. MAXIMUM VARIANCE OF .002 [.05].
6. DIMENSION APPLIES TO TERMINALS AND GROUND PLANE.
7. T-1SXX-XX-L CAN BE SUBSTITUTED FOR T-1SXX-XX-F.
8. NOTE DELETED.
9. GROUND PLANE PRESS HEIGHT MUST BE .003 [.08] LESS THAN THE MAX HEIGHT OR .001 [.03] GREATER THAN THE MINIMUM HEIGHT OF THE TERMINALS.
10. T-1R36 RETENTION TO BODY TO BE 1.0 LBF.
11. FOR NEW APPLICATIONS REQUIRING THESE POSITIONS, PLEASE CONTACT SAMTEC INTERCONNECT PROCESSING GROUP.
12. DUE TO THE HIGH AMOUNT OF INSERTION FORCE NEEDED, THE -LC OPTION IS NOT COMPATIBLE WITH AUTO PLACEMENT. SAMTEC RECOMMENDS MANUAL PLACEMENT FOR ALL ASSEMBLIES WITH THE -LC OPTION.
13. ROW TO ROW MIN IS .152, PIN CAN EXTEND PAST WALL .003 MAX.

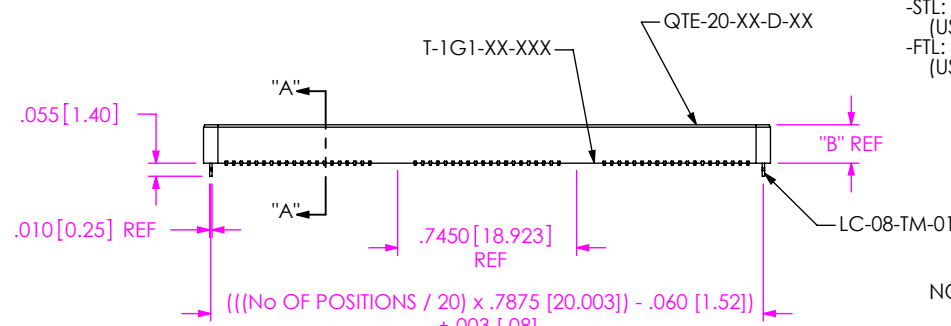
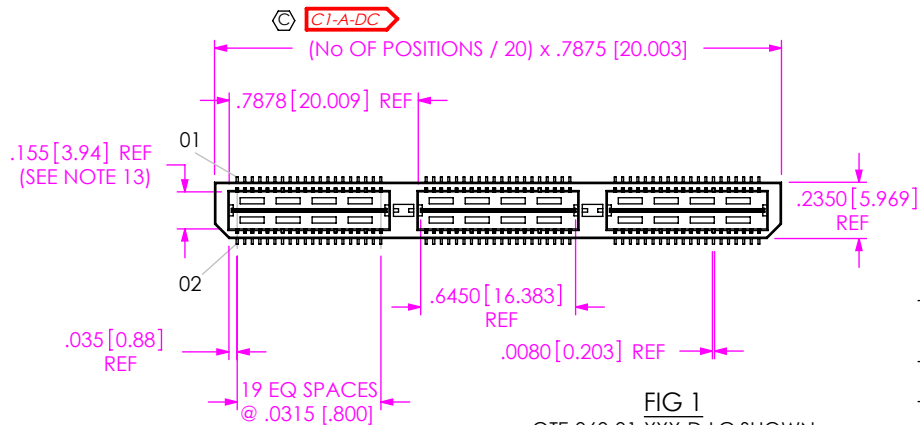

-LC: LOCKING CLIP OPTION SHOWN

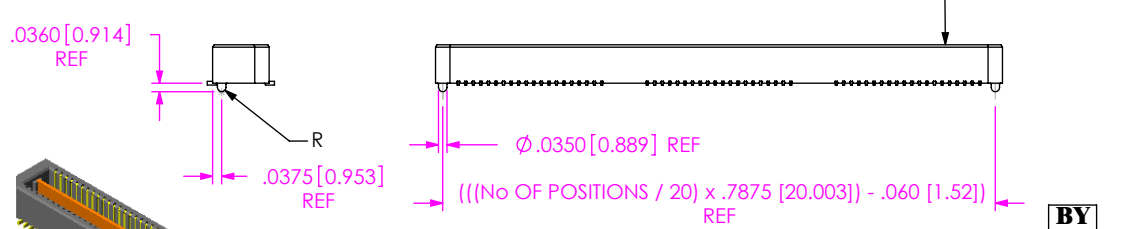

-A: ALIGNMENT PIN OPTION SHOWN
(STYLES -01, -02 & -03)

TABLE 2

No OF POSITIONS	COPLANARITY INCLUDING GP
-020 THRU -060	.004 [.10]
-080 THRU -100	.006 [.15]

(SEE NOTE 11)

TABLE 1

STYLE	"A"	"B"	BODY	GROUND PLANE	TERMINAL	MATED HEIGHT WITH QSE-01
-01	.1880 [4.287]	.1800 [4.094]	QTE-20-01-D-XX	T-1G1-01-XXX	T-1S39-01-XXX	.197 [5.00] REF
-02	.2861 [7.267]	.2781 [7.064]	QTE-20-02-D-XX	T-1G1-02-XXX	T-1S39-02-XXX	.315 [8.00] REF
-03	.4042 [10.267]	.3962 [10.063]	QTE-20-03-D-XX	T-1G1-03-XXX	T-1S39-03-XXX	.433 [11.00] REF

BY

C12-A-LMV

UNLESS OTHERWISE SPECIFIED, DIMENSIONS ARE IN INCHES. TOLERANCES ARE:
 DECIMALS .XX: $\pm .01$ [.3]
 .XXX: $\pm .005$ [.13]
 .XXXX: $\pm .0020$ [.051]

PROPRIETARY NOTE
 THIS DOCUMENT CONTAINS INFORMATION CONFIDENTIAL AND PROPRIETARY TO SAMTEC, INC. AND SHALL NOT BE REPRODUCED OR TRANSFERRED TO OTHER DOCUMENTS OR DISCLOSED TO OTHERS OR USED FOR ANY PURPOSE OTHER THAN THAT WHICH IT WAS OBTAINED WITHOUT THE EXPRESSED WRITTEN CONSENT OF SAMTEC, INC.



520 PARK EAST BLVD, NEW ALBANY, IN 47150
 PHONE: 812-944-6733 FAX: 812-948-5047
 e-Mail info@SAMTEC.com code 55322

MATERIAL: DO NOT SCALE DRAWING SHEET SCALE: 1:0.8

INSULATOR: LCP, COLOR: BLACK
 TERMINAL: PHOS BRONZE
 GROUND PLANE: PHOS BRONZE

DESCRIPTION:
 .8mm DOUBLE ROW HS TERMINAL ASSEMBLY

DWG. NO.
QTE-XXX-XX-XXX-D-XXX

BY: DEAN P 09-14-2010 SHEET 1 OF 6

DO NOT SCALE FROM THIS PRINT

FIG 2
-K: POLYIMIDE FILM PAD
[USE K-DOT-.276-.375-.005]

TABLE 3	
STYLE	"R"
-01	.173[4.39]
-02	.291[7.39]
-03	.409[10.39]
-04	.605[15.37]
-05	.721[18.31]
-06	.840[21.33]
-09	.528 [13.41]
-10	.567[14.37]

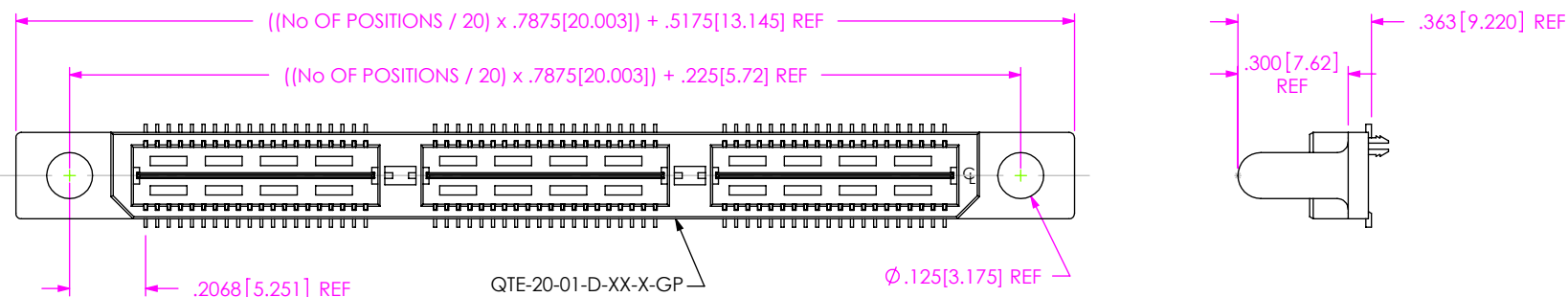
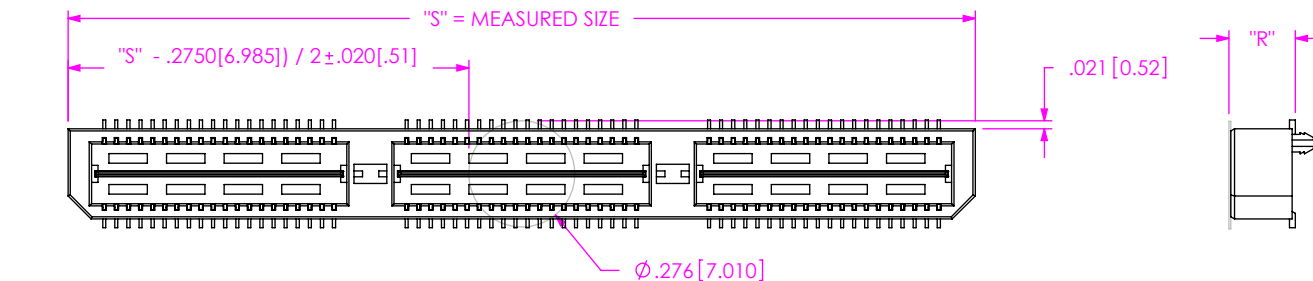

FIG 3
-GP: GUIDE POST OPTION
(-01 LEAD STYLE ONLY)
(SAME AS FIG 1, UNLESS OTHERWISE STATED)

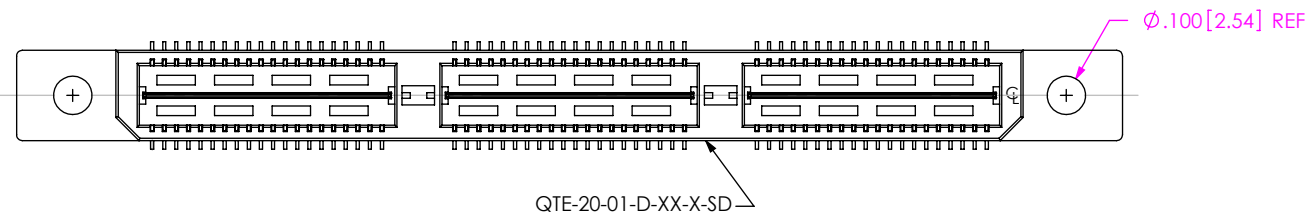

FIG 4
-SD: SCREW DOWN OPTION
(-01 LEAD STYLE ONLY)
(SAME AS FIG 3, UNLESS OTHERWISE STATED)

PROPRIETARY NOTE
THIS DOCUMENT CONTAINS INFORMATION
CONFIDENTIAL AND PROPRIETARY TO
SAMTEC, INC. AND SHALL NOT BE REPRODUCED
OR TRANSFERRED TO OTHER DOCUMENTS OR
DISCLOSED TO OTHERS OR USED FOR ANY
PURPOSE OTHER THAN THAT WHICH IT WAS
OBTAINED WITHOUT THE EXPRESSED WRITTEN
CONSENT OF SAMTEC, INC.

DO NOT SCALE DRAWING

SHEET SCALE: 2:1

samtec

520 PARK EAST BLVD, NEW ALBANY, IN 47150
PHONE: 812-944-6733 FAX: 812-948-5047
e-Mail info@SAMTEC.com code 55322

DESCRIPTION:
.8mm DOUBLE ROW HS TERMINAL ASSEMBLY

DWG. NO. QTE-XXX-XX-XXX-D-XXX

BY: DEAN P 09-14-2010 SHEET 2 OF 6

FIG 5
 QTE-060-04-X-D-LC SHOWN
 [DIFFERENT AS SHOWN, OTHERWISE SAME AS FIG 1]
 (STYLES -04, -05 & -06)

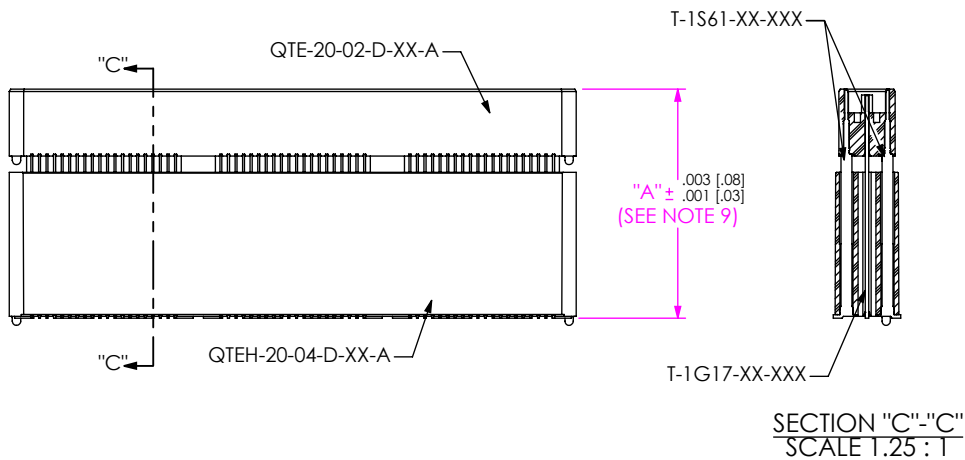
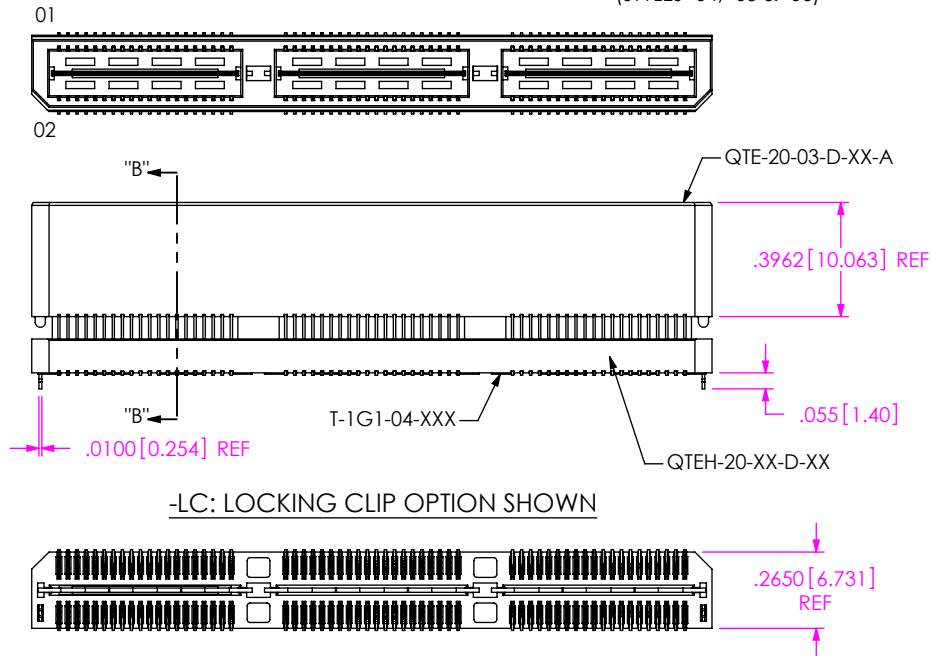

FIG 6
 QTE-060-07-X-D-A SHOWN
 [DIFFERENT AS SHOWN, OTHERWISE SAME AS FIG 5]
 (STYLES -07 & -08)

TABLE 4						MATED HEIGHT WITH QSE-01
STYLE	"A"	GROUND PLANE	TERMINAL	BOTTOM SPACER BODY	TOP BODY	
-04	6010 [15 265]	T-1G1-04-XXX	T-1S41-04-XXX	QTEH-20-01-D-XXX	QTE-20-03-D-XXX	630 [16.00] REF
-05	7190 [18 263]	T-1G1-05-XXX	T-1S41-05-XXX	QTEH-20-01-D-XXX	QTE-20-03-D-XXX	748 [19.00] REF
-06	8370 [21 260]	T-1G1-06-XXX	T-1S41-06-XXX	QTEH-20-02-D-XXX	QTE-20-03-D-XXX	866 [22.00] REF
-07	9540 [24 232]	T-1G17-01-XXX	T-1S61-21-XXX	QTEH-20-04-D-XXX	QTE-20-02-D-XXX	984 [25.00] REF
-08	1.1510 [29 235]	T-1G17-02-XXX	T-1S61-22-XXX	QTEH-20-04-D-XXX	QTE-20-02-D-XXX	1.181 [30.00] REF
-09	5220 [13 259]	T-1G1-09-XXX	T-1S60-09-XXX	QTEH-20-01-D-XXX	QTE-20-02-D-XXX	551 [14.00] REF
-10	5606 [14 239]	T-1G1-10-XXX	T-1S60-10-XXX	QTEH-20-01-D-XXX	QTE-20-02-D-XXX	591 [15.00] REF

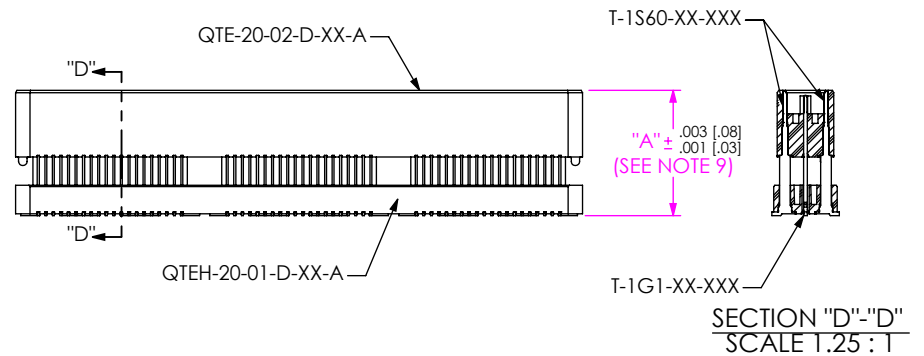
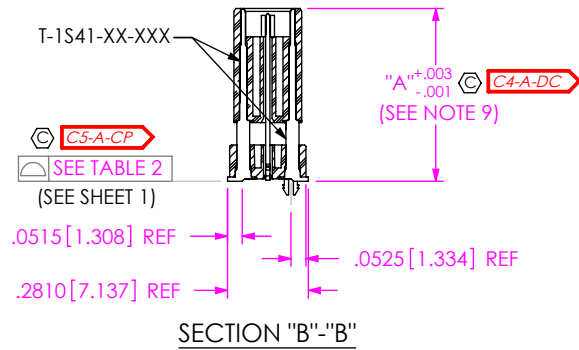

FIG 7
 QTE-060-09-X-D-A SHOWN
 [DIFFERENT AS SHOWN, OTHERWISE SAME AS FIG 5]
 (STYLES -09 & -10)

F:\DWG\MISC\MKTG\QTE-XXX-XX-X-D-XXX-MKT.SLDDRW

PROPRIETARY NOTE
 THIS DOCUMENT CONTAINS INFORMATION CONFIDENTIAL AND PROPRIETARY TO SAMTEC, INC. AND SHALL NOT BE REPRODUCED OR TRANSFERRED TO OTHER DOCUMENTS OR DISCLOSED TO OTHERS OR USED FOR ANY PURPOSE OTHER THAN THAT WHICH IT WAS OBTAINED WITHOUT THE EXPRESSED WRITTEN CONSENT OF SAMTEC, INC.

DO NOT SCALE DRAWING

SHEET SCALE: 1:0.666667



520 PARK EAST BLVD. NEW ALBANY, IN 47150
 PHONE: 812-944-6733 FAX: 812-948-5047
 e-Mail: info@SAMTEC.com code 55322

DESCRIPTION:
 .8mm DOUBLE ROW HS TERMINAL ASSEMBLY

DWG. NO. **QTE-XXX-XX-XXX-D-XXX**

BY: DEAN P 09-14-2010 SHEET 3 OF 6

FIG 8
 -FL: FRICTION LOCKS
 (ONLY AVAILABLE ON -01 & -02 LEAD STYLES)
 (NOT AVAILABLE WITH -GP, -SD OPTIONS)
 (SAME AS FIG 1, UNLESS OTHERWISE STATED)

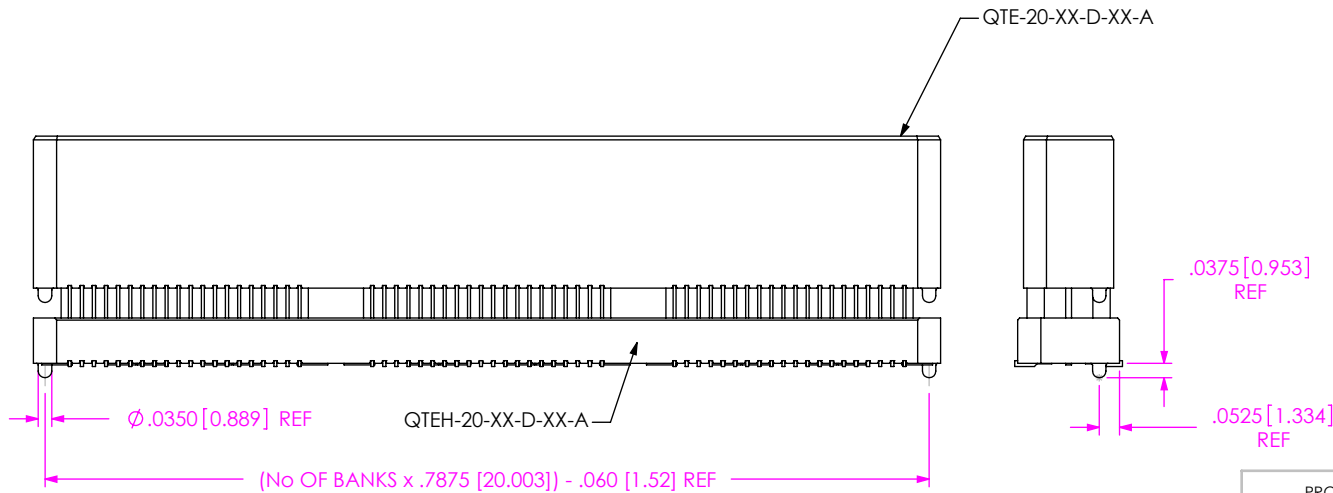
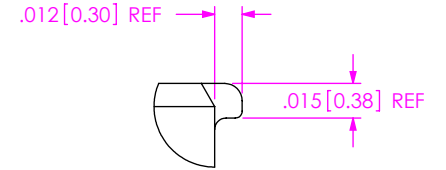
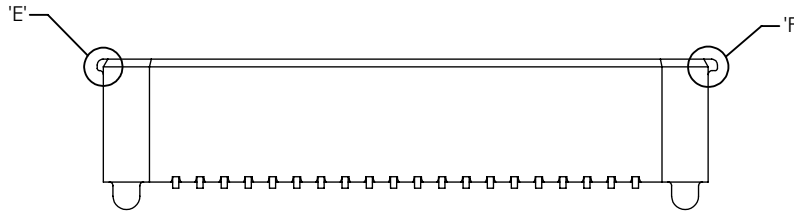
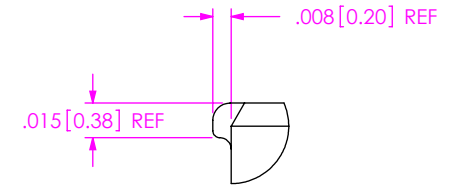
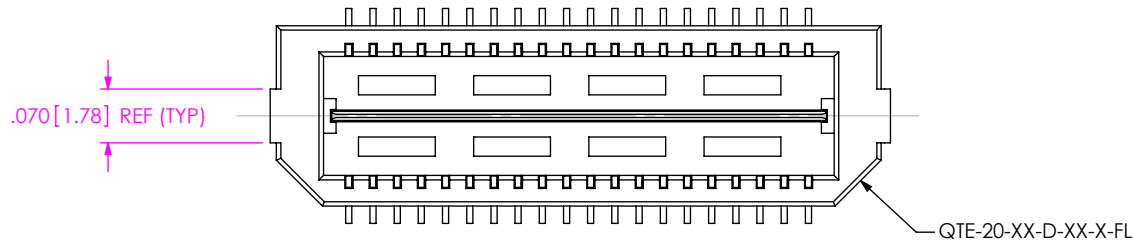

-A: ALIGNMENT PIN OPTION
 (STYLES -04, -05, -06, -07, -08, -09 & -10)

PROPRIETARY NOTE
 THIS DOCUMENT CONTAINS INFORMATION CONFIDENTIAL AND PROPRIETARY TO SAMTEC, INC. AND SHALL NOT BE REPRODUCED OR TRANSFERRED TO OTHER DOCUMENTS OR DISCLOSED TO OTHERS OR USED FOR ANY PURPOSE OTHER THAN THAT WHICH IT WAS OBTAINED WITHOUT THE EXPRESSED WRITTEN CONSENT OF SAMTEC, INC.

DO NOT SCALE DRAWING

SHEET SCALE: 2:1



520 PARK EAST BLVD, NEW ALBANY, IN 47150
 PHONE: 812-944-6733 FAX: 812-948-5047
 e-Mail info@SAMTEC.com code 55322

DESCRIPTION:
.8mm DOUBLE ROW HS TERMINAL ASSEMBLY

DWG. NO.
QTE-XXX-XX-XXX-D-XXX

BY: DEAN P 09-14-2010 SHEET 4 OF 6

FIG 9
 -RT1: RETENTION OPTION
 (ONLY AVAILABLE ON -01 LEAD STYLE) (MUST USE -A OPTION)
 (NOT AVAILABLE WITH -LC, -GP, -SD, OR -FL OPTIONS)
 (NOT AVAILABLE ON -100 POSITION)
 (SAME AS FIG 1, UNLESS OTHERWISE STATED)

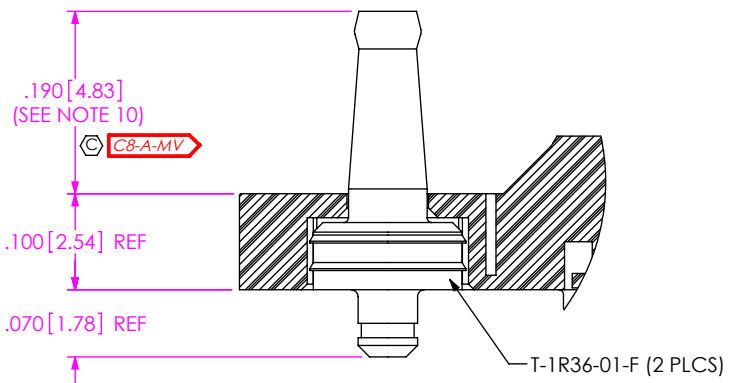
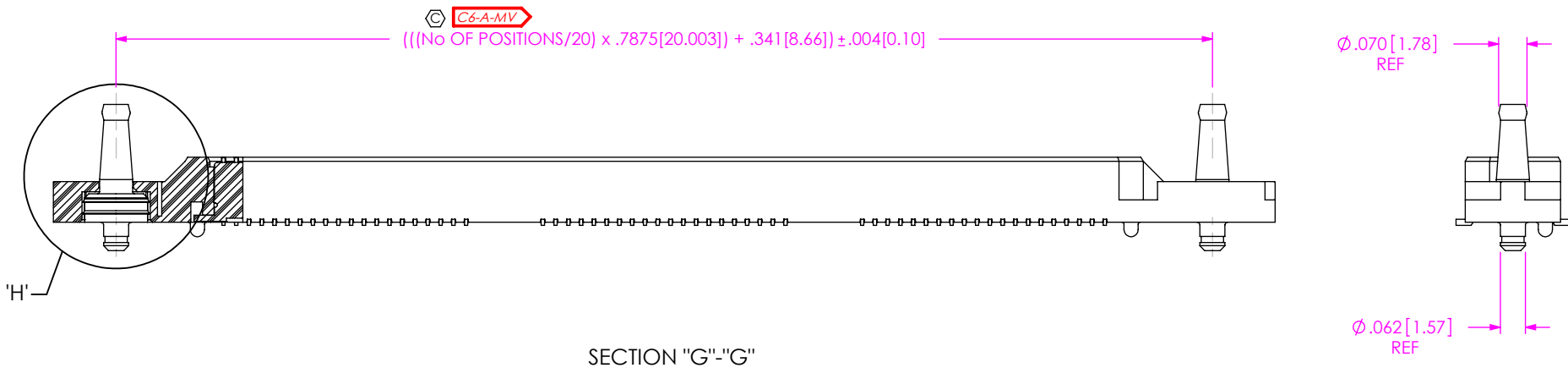
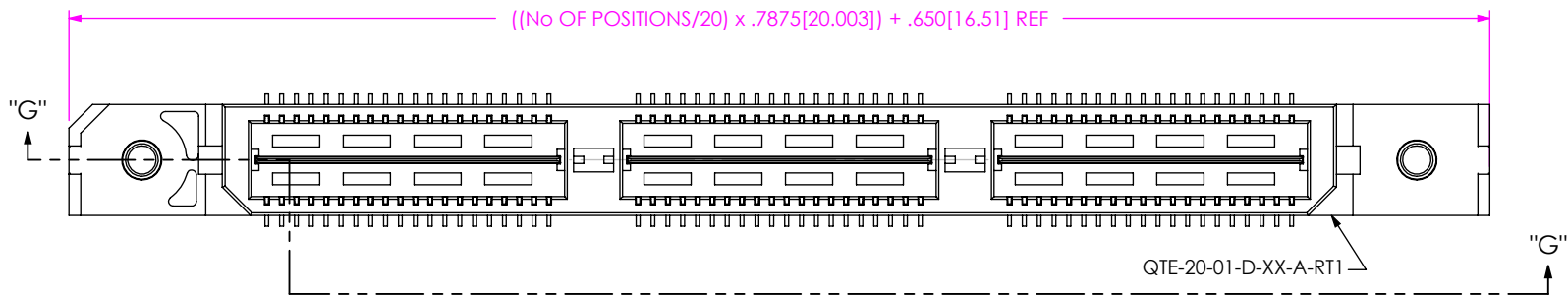

DETAIL 'H'
 SCALE 5:1

PROPRIETARY NOTE
 THIS DOCUMENT CONTAINS INFORMATION
 CONFIDENTIAL AND PROPRIETARY TO
 SAMTEC, INC. AND SHALL NOT BE REPRODUCED
 OR TRANSFERRED TO OTHER DOCUMENTS OR
 DISCLOSED TO OTHERS OR USED FOR ANY
 PURPOSE OTHER THAN THAT WHICH IT WAS
 OBTAINED WITHOUT THE EXPRESSED WRITTEN
 CONSENT OF SAMTEC, INC.

DO NOT SCALE DRAWING
 SHEET SCALE: 1:0.4



520 PARK EAST BLVD, NEW ALBANY, IN 47150
 PHONE: 812-944-6733 FAX: 812-948-5047
 e-Mail info@SAMTEC.com code 55322

DESCRIPTION:
 .8mm DOUBLE ROW HS TERMINAL ASSEMBLY
 DWG. NO. QTE-XXX-XX-XXX-D-XXX

REVISION BY

FIG 10
 -TR: PACKAGING OPTION
 (NOT AVAILABLE ON LEAD SYTTLES -05, -06, -07 & -08)
 (SAME AS FIG 1, UNLESS OTHERWISE STATED)

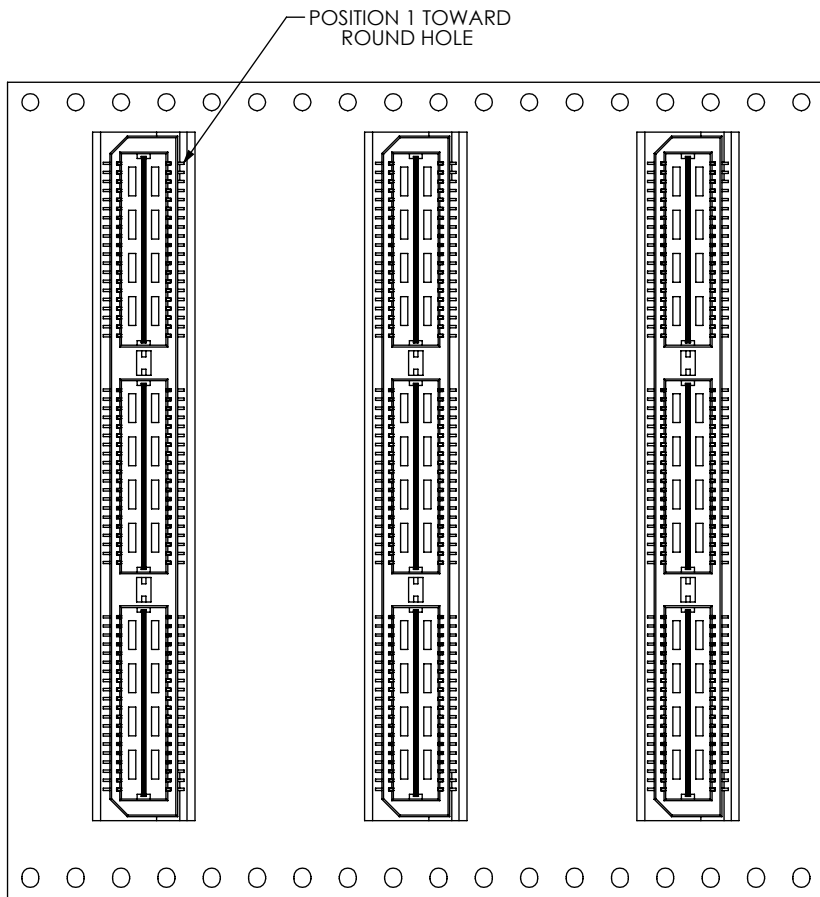

USER DIRECTION OF UN-REELING POCKET NOT DETAILED →

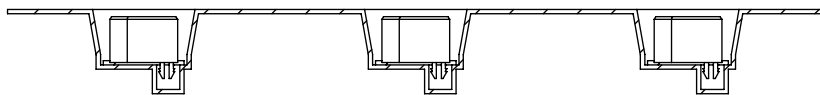
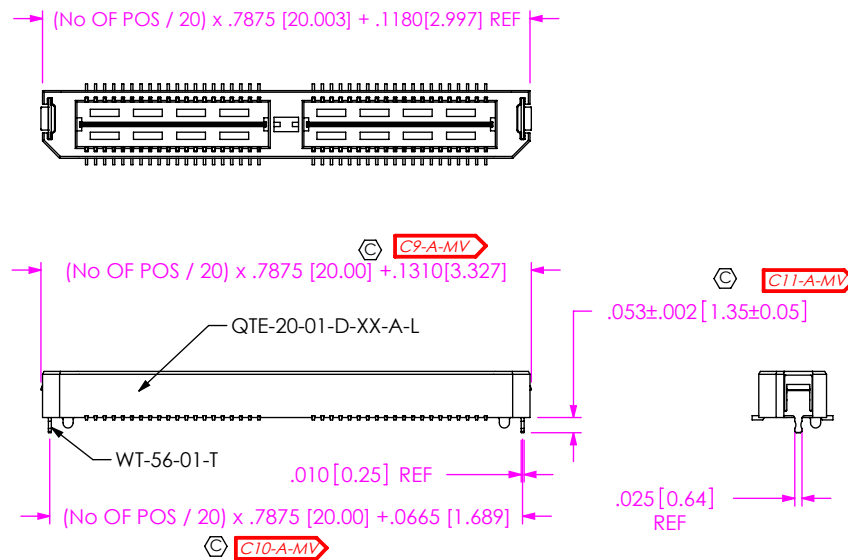

FIG 11
 -L: LATCHING OPTION
 (40 POS. MAX.)
 (MUST USE -A OPTION)
 (AVAILABLE ON -01 LEAD SYTLE ONLY)
 (NOT AVAILABLE WITH -LC, -GP, -SD, -FL, OR -RT1)
 (SAME AS FIG 1, UNLESS OTHERWISE STATED)



BY

CRITICAL DIMENSION INSPECTION INSTRUCTION TABLE	
ASSEMBLY OPERATION	IN PROCESS INSPECTION
FILL T-1SXX	C1, C2, C3, C4, C5, C12
ADD -RT1 OPTION	C6, C8
ADD -L OPTION	C9, C10, C11

PROPRIETARY NOTE
 THIS DOCUMENT CONTAINS INFORMATION CONFIDENTIAL AND PROPRIETARY TO SAMTEC, INC. AND SHALL NOT BE REPRODUCED OR TRANSFERRED TO OTHER DOCUMENTS OR DISCLOSED TO OTHERS OR USED FOR ANY PURPOSE OTHER THAN THAT WHICH IT WAS OBTAINED WITHOUT THE EXPRESSED WRITTEN CONSENT OF SAMTEC, INC.

DO NOT SCALE DRAWING

SHEET SCALE: 1:0.8

samtec

520 PARK EAST BLVD, NEW ALBANY, IN 47150
 PHONE: 812-944-6733 FAX: 812-948-5047
 e-Mail: info@SAMTEC.com code 55322

DESCRIPTION:
 .8mm DOUBLE ROW HS TERMINAL ASSEMBLY

DWG. NO. **QTE-XXX-XX-XXX-D-XXX**

BY: DEAN P 09-14-2010 SHEET 6 OF 6