

THIS DOCUMENT AND THE DATA DISCLOSED HEREIN OR HEREWITH IS NOT TO BE REPRODUCED, USED, OR DISCLOSED IN WHOLE OR IN PART TO ANYONE WITHOUT PERMISSION OF VICOR CORP.

REV.	DESCRIPTION	DATE	APPROVED
1	RELEASED PER E050350	11/16/05	EF
2	REVISED PER E072386	10/01/2007	REJH
3	REVISED PER E090033	01/09/09	REJH

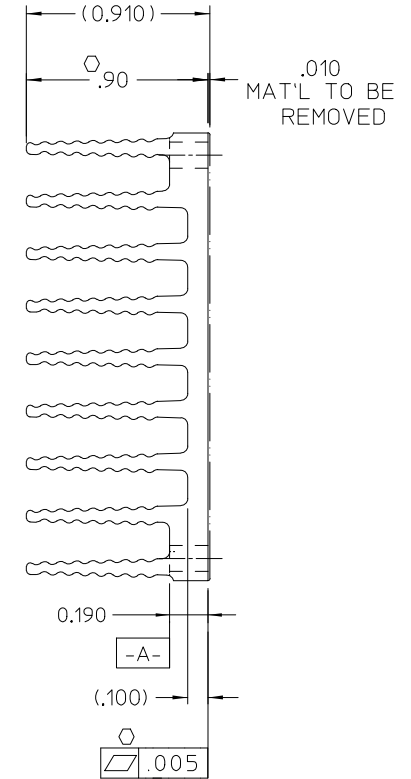
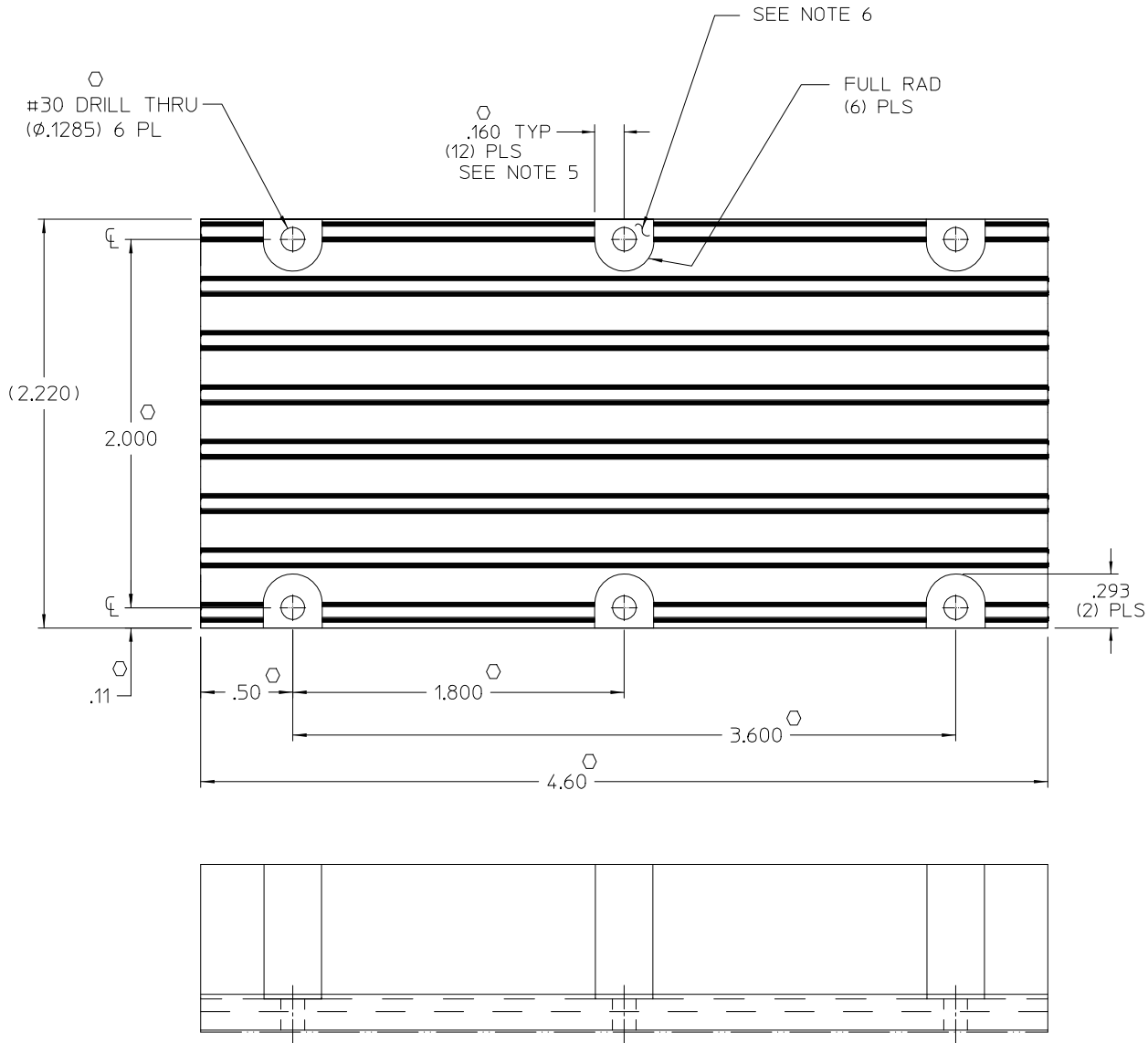

NOTES

1. MAKE FROM VICOR EXTRUSION P/N 15948.
2. REMOVE ALL BURRS AND SHARP EDGES.
3. CLEAR FINISH, RoHS COMPLIANT, CHROMIUM FREE PER CST-0001, LATEST REVISION
4. Ø DENOTES CRITICAL CHARACTERISTICS FOR LOT INSPECTION.
5. DIMENSION APPLIES AT SURFACE -A- (12) PLS.
6. MACHINED SURFACE TO BE .010 MAX BELOW SURFACE -A- (6) PLS.

DRAWN BY <i>P.E.IENI</i>		DATE 06/28/05	
UNLESS OTHERWISE SPECIFIED DIMENSIONS ARE IN INCHES - TOLERANCES ARE: FRACTIONS DECIMALS ANGLES +1/64 .XX+ .01 °1P .XXX-.005			
THIRD ANGLE PROJECTION 		SIZE C	FSCM NO. 67131
DO NOT SCALE DRAWING		SCALE 2=1	DWG NO. 30181
		REV 3	SHEET 1 OF 1

**HS CFG "A" LONG .9H  
LOW FLOW, THRU HOLE**