

Plastic Infrared Emitting Diode

OP265WPS



Features:

- T-1 (3 mm) package style
- Broad irradiance pattern
- Point source with flat lens
- Higher power output than GaAs at equivalent drive currents
- 850 nm diode

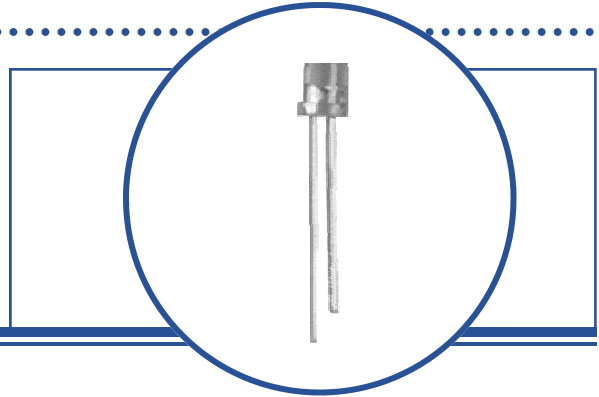

Description:

The **OP265WPS** *point source* model is a flat-lensed 850 nm diode with a *broad* radiation pattern that provides relatively even illumination over a large area. Its stable forward voltage (V_F) vs. temperature characteristic makes this device appropriate for applications where voltage is limited (such as battery operation), while the low rise time/fall time (t_r/t_f) makes it ideal for high-speed operation.

OP265 devices conform to the OP505 and OP535 series devices.

Please refer to Application Bulletins 208 and 210 for additional design information and reliability (degradation) data.

Applications:

- Space-limited applications
- Applications requiring coupling efficiency
- Precision optical designs
- Battery-operated or voltage-limited applications

Ordering Information					
Part Number	LED Peak Wavelength	Output Power (mW/cm ²) Min / Max	I _F (mA) Typ / Max	Total Beam Angle	Lead Length
OP265WPS	850 nm	.055 / .55	20 / 50	120°	0.50"

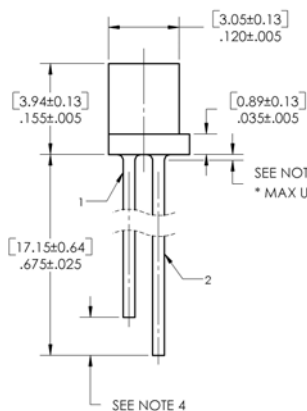

DIMENSIONS ARE IN: [MILLIMETERS]
INCHES

SEE NOTE 3
* MAX UNDERFILL ALLOWED IS .015"

NOTES:

1. OUTSIDE DISCRETE SHELL IS POLYSULFONE P1700 CLEAR.
2. THIS LED IS BUILT WITH A 0.011 X 0.011 GaAs CHIP.
3. MAX ALLOWABLE EPOXY MINISCUS IS 0.030.
4. FOR IDENTIFICATION PURPOSES, ANODE LEAD IS .045 ± .005 LONGER THAN THE CATHODE LEAD.



Pin #	LED
1	Cathode
2	Anode

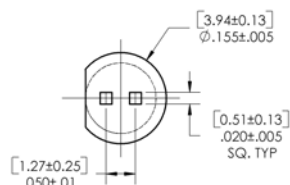

DISCRETE PIN-OUT

- 1 CATHODE
- 2 ANODE



RoHS

OPTEK reserves the right to make changes at any time in order to improve design and to supply the best product possible.

CONTAINS POLYSULFONE
To avoid stress cracking, we suggest using ND Industries' **Vibra-Tite** for thread-locking. **Vibra-Tite** evaporates fast without causing structural failure in OPTEK'S molded plastics.

Plastic Infrared Emitting Diode

OP265WPS



Absolute Maximum Ratings ($T_A = 25^\circ\text{C}$ unless otherwise noted)

Storage and Operating Temperature Range	-40° C to +100° C
Reverse Voltage	2.0 V
Continuous Forward Current	50 mA
Peak Forward Current (1 μs pulse width, 300 pps)	3.0 A
Lead Soldering Temperature [1/16 inch (1.6 mm) from case for 5 seconds with soldering iron]	260° C ⁽¹⁾
Power Dissipation	100 mW ⁽²⁾

Notes:

1. RMA flux is recommended. Duration can be extended to 10 second maximum when flow soldering. A maximum of 20 grams force may be applied to the leads when soldering.
2. Derate linearly at 1.33 mW/° C above 25° C.
3. $E_{E(APT)}$ is a measurement of the average apertured radiant incidence upon a sensing area 0.081" (2.06 mm) in diameter, perpendicular to and centered on the mechanical axis of the lens and 0.590" (14.99 mm) from the measurement surface. $E_{E(APT)}$ is not necessarily uniform within the measured area.

Electrical Characteristics ($T_A = 25^\circ\text{C}$ unless otherwise noted)

SYMBOL	PARAMETER	MIN	TYP	MAX	UNITS	TEST CONDITIONS
--------	-----------	-----	-----	-----	-------	-----------------

Input Diode

$E_{E(APT)}$	Apertured Radiant Incidence	2.70	-	-	mW/cm ²	$I_F = 20\text{ mA}^{(3)}$
V_F	Forward Voltage	-	-	1.80	V	$I_F = 20\text{ mA}$
I_R	Reverse Current	-	-	20	μA	$V_R = 2\text{ V}$
λ_P	Wavelength at Peak Emission	-	850	-	nm	$I_F = 10\text{ mA}$
B	Spectral Bandwidth between Half Power Points	-	-	-	nm	$I_F = 20\text{ mA}$

OPTEK reserves the right to make changes at any time in order to improve design and to supply the best product possible.

OP265WPS

Forward Voltage vs Forward Current vs Temperature

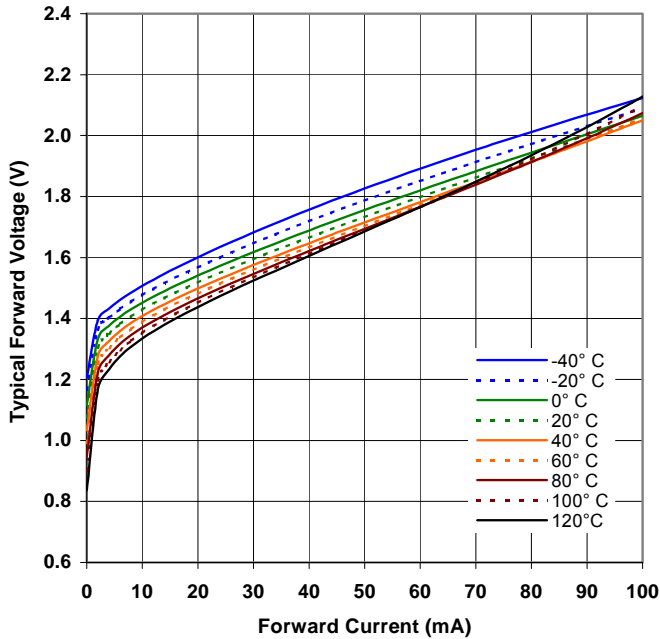

Optical Power vs Forward Current vs Temperature

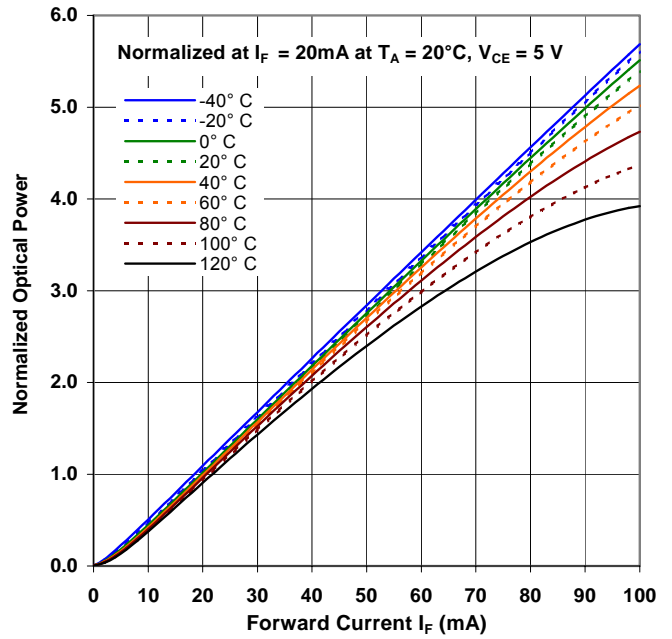

Distance vs Power vs Forward Current

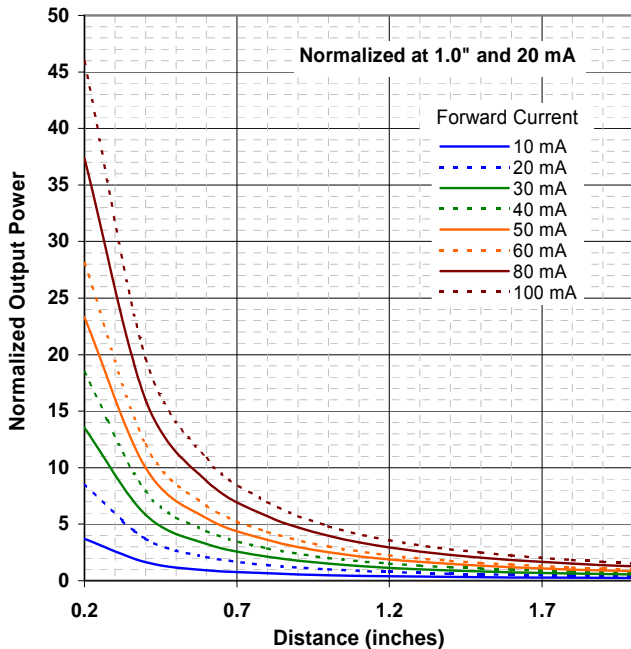

OPTEK reserves the right to make changes at any time in order to improve design and to supply the best product possible.