

RL78/I1A DC/DC LED Control Demonstration Kit

User's Manual: Hardware

16-bit Microcontroller

RL78/I1A

R5F107DEG

All information contained in these materials, including products and product specifications, represents information on the product at the time of publication and is subject to change by Renesas Electronics Corp. without notice. Please review the latest information published by Renesas Electronics Corp. through various means, including the Renesas Electronics Corp. website (<http://www.renesas.com>).

Preface

Readers This manual is intended for users who want to understand the functions of the concerned microcontrollers.

Purpose This manual presents the hardware manual for the concerned microcontrollers.

Organization This system specification describes the following sections:

- **Introduction**
- System configuration
- Board components
- Getting started
- Hardware installation
- Software installation
- **How to use WriteEZ5 flash programming software**
- Applilet EZ for HCD controller
- Troubleshooting
- Schematics
- Bill of materials

Module instances These microcontrollers may contain several instances of a dedicated module. In general the different instances of such modules are identified by the index “n”, where “n” counts from 0 to the number of instances minus one.

Legend Symbols and notation are used as follows:

- Weight in data notation: Left is high order column, right is low order column
- Active low notation: xxx (pin or signal name is over-scored) or /xxx (slash before signal name) or _xxx
- Memory map address: High order at high stage and low order at low stage

Note Additional remark or tip

Caution Item deserving extra attention

Numeric notation

Binary:	xxxx or xxxB
Decimal:	xxxx
Hexadecimal	xxxxH or 0x xxxx

Numeric prefixes Representing powers of 2 (address space, memory capacity):

K (kilo):	$2^{10} = 1024$
M (mega):	$2^{20} = 1024^2 = 1,048,576$
G (giga):	$2^{30} = 1024^3 = 1,073,741,824$

Register contents X, x = don't care



Diagrams Block diagrams do not necessarily show the exact wiring in hardware but the functional structure. Timing diagrams are for functional explanation purposes only, without any relevance to the real hardware implementation.

Safety Precautions

This document describes items to be observed to ensure the safe use of this evaluation board. Be sure to read this document before using the board.

Symbols Used



This document uses the following symbols for items to be observed to ensure the safe use of the unit. The symbols are followed by a brief explanation of the possible extent of problems which may occur if the items are not observed.

 Danger	The risk is high if the warning is not observed, and the user may suffer death or serious injury.
 Warning	The user may suffer death or serious injury if the warning is not observed.
 Caution	Human injury or property damage may occur if the caution is not observed.

The following symbols express behaviors that are prohibited in order to prevent injury or accident.

 General prohibition The action mentioned is prohibited.	 Do not touch Touching the specified location may cause injury.	 Do not disassemble Disassembly may cause a problem such as electric shock or product failure.
 Keep away from water Use near water poses the risk of electric shock or product failure if moisture were to contact the unit.	 Flammable Proximity to flame may cause the unit to catch fire.	 Do not touch with wet hands Touching with wet hands may cause electric shock or product failure.











The following symbols are used for cautions to prevent product failure and accidents.

 General caution Unspecified general cautions	 Caution: Hot Human injury due to a high temperature
--	---

The following symbols are used for instructions to prevent product failure and accidents.

 Action required of the user	 Instruction to unplug from AC power supply
---	--

Warnings

 Warning	
	<p>Be careful to avoid burns. The temperature of this part of board increases when AC power is connected.</p>
	<p>Be careful of LED brightness and the LED On/Off interval. Simulations of strong light may cause symptoms linked to an epileptic condition.</p>
	<p>Do not use this board for a purpose other than the evaluation of an MCU. This board does not include the safety measures or anti-EMI measures required for lighting equipment.</p>
	<p>Do not heat the board or expose it to fire and do not short the terminals. Doing so may cause the product to fail, heat up, catch fire, or rupture.</p>
	<p>Do not disassemble or modify the board. Doing so may cause the product to fail, emit smoke, or catch fire, or result in electric shock.</p>
	<p>Do not touch with wet hands. Doing so while connected to power may cause the product to fail or result in electric shock.</p>
	<p>Do not look directly at the LEDs on this board. Doing so may weaken eyesight.</p>
	<p>Do not drop the board or subject the board to heavy impact. Doing so may break or damage the board, causing fire or electric shock.</p>
	<p>Do not turn on the power switch when the AC adapter, interface cable, or other cables are not properly connected. Doing so may cause the product to fail, heat up, or catch fire, or result in electric shock.</p>
	<p>Do not plug in or unplug a connector or cable with power applied to the board. Doing so may cause the product to fail, heat up, or catch fire, or result in electric shock.</p>
	<p>Do not move this board when the AC adapter or any cables are connected. Doing so may damage cables and cause the product to fail, heat up, or catch fire, or result in electric shock.</p>
	<p>Use this board with a spacer and on an electrically isolated bench. If a conductor contacts the board, the product may fail, heat up, or catch fire, or it may result in electric shock.</p>
	<p>Use an AC adapter adapted to the safety standard of each country. Using an inappropriate AC adapter may cause the product to fail, heat up, or catch fire, or result in electric shock.</p>
	<p>Use the specified AC adapter. Using an AC adapter other than that specified may cause the product to fail, heat up, or catch fire, or result in electric shock.</p>
	<p>Use an AC adapter of the following size and DC plug polarity. EIAJ Type2 Plug (outer diameter: 4.0 mm, inner diameter: 1.7 mm) Using another type of AC adapter may cause the product to fail, heat up, or catch fire, or result in electric shock.</p> <div style="text-align: right;">  </div>
<p>Confirm that the outlet is near this board and can be easily unplugged.</p>	



Warning



If smoke or an abnormal smell or sound is emitted or if overheating occurs, promptly switch off the board power and unplug the AC power supply.

Using the board in such a state poses a risk of fire, burning or electric shock.

Cautions



Caution



Do not use or store this board in any of the following locations.

- Environments with excessive water, humidity, steam, dust, fume, etc.
- Environments where static electricity or electrical noise is readily generated.

Such influences can lead to electric shock or product failure.

If liquid enters the board, disconnect the power supply, and consult your dealer or Renesas Electronics sales representative.

Even if the unit appears to be dry, internal moisture may remain.



Do not directly touch LEDs on this board.

Doing so may cause product failure.



To prevent static electricity damage, guard against static discharge when touching metal parts such as the connector.

Static electricity can cause product failure.



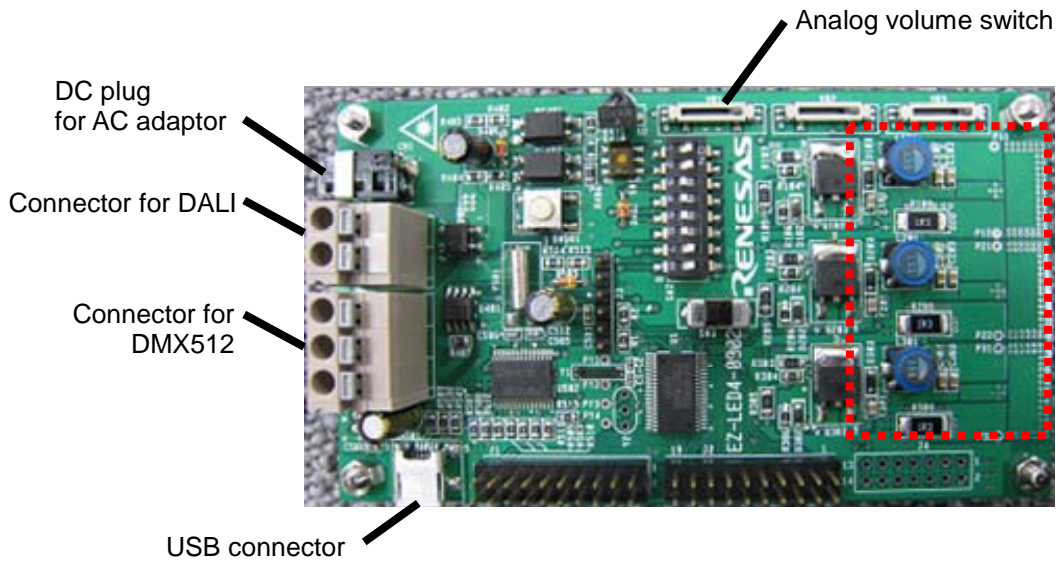

Appearance of the board

Surface appearance (top view)

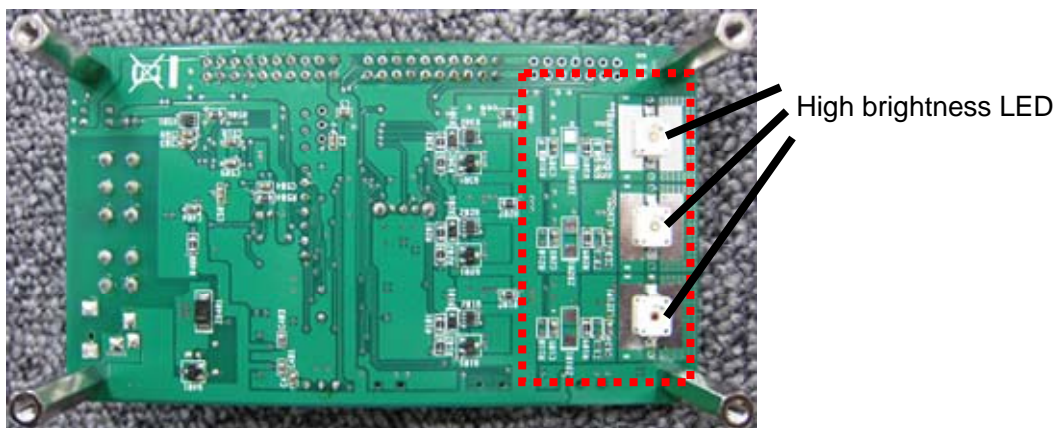

Surface appearance (back view)



 Warning	
	<p>Be careful to avoid burns.</p> <p>Parts of the board, especially the area enclosed by a dotted line, become extremely hot.</p>
	<p>Do not look directly at LEDs on this board.</p> <p>Doing so may weaken eyesight.</p> <p>Use this board with the LED mounting surface back.</p>
	<p>Use a specified AC adaptor.</p> <p>Using an AC adaptor other than that specified causes the product to fail, heat up, or catch fire, or electric shock.</p>



Caution



Do not touch directly LEDs on this board.

Doing so may cause a product failure.

For usage of this board, see the User's Manual. The User's Manual can be downloaded from the following webpage.

URL: http://tool-support.renesas.com/eng/toolnews/download/exel/solution_lighting.html

Table of Contents

Chapter 1	Introduction	1
1.1	Main features of RL78/I1A DC/DC LED Control Evaluation Board.....	1
1.2	System requirements.....	2
1.3	Package contents.....	2
Chapter 2	System Configuration	3
2.1	RL78/I1A DC/DC LED Control Evaluation Board	3
2.2	Host Computer	3
2.3	Power Supply	3
Chapter 3	Board Components	4
3.1	Configuration Switch SW2	4
3.1.1	Normal Operation Mode.....	4
3.1.2	On-Board Debug (OCD) Mode / Flash Programming Mode	5
3.1.3	E1 On-Chip Debug Mode	5
3.1.4	Virtual UART Mode.....	6
3.2	Configuration Switch SW1	6
3.3	Configuration Switch SW3	6
3.4	Reset Switch SW501	7
3.5	External Power Supply CN1	7
3.6	DALI Interface Connector CN2.....	7
3.7	DMX512 Interface Connector CN3	7
3.8	InfraRed Detector U2	7
3.9	E1 Emulator Connector J4	8
3.10	Programming Connector J3.....	8
3.11	Mini-B USB Interface Connector CN501.....	8
3.12	External Connectors J1 and J2.....	9
3.13	Low Power 32 KHz Resonator Y1	11
3.14	RL78/I1A Memory Map.....	11
Chapter 4	Getting Started.....	12
4.1	Installed Contents	12
Chapter 5	Hardware Installation	13
Chapter 6	Software Installation	14
Chapter 7	How to Use WriteEZ5 Flash Programming Software	15
Chapter 8	Applilet EZ for HCD Controller	22
8.1	General Settings	22

8.2	Fix Dimmer Program.....	24
8.3	Variable Dimmer Program	27
8.4	Analog Input Dimmer Program	29
8.5	DMX512 Dimmer Program	30
8.6	DALI Dimmer Program.....	32
8.7	IR Remote Control Dimmer Program.....	34
Chapter 9	Troubleshooting	36
Chapter 10	Schematics	38
Chapter 11	Bill of Materials	40

Chapter 1 Introduction

The *RL78/I1A DC/DC LED Control Demonstration Kit* comes with the *RL78/I1A DC/DC LED Control Evaluation Board* and a DVD containing all the appropriate software tools and documentation.

The *RL78/I1A DC/DC LED Control Evaluation Board* is an evaluation board for the new Renesas RL78/I1A microcontroller. It supports On-Board debugging, flash programming, and is intended to demonstrate the RL78/I1A MCU's special features dedicated to LED lighting system control.

1.1 Main features of RL78/I1A DC/DC LED Control Evaluation Board

- LED lighting system control demonstration capabilities
 - *RL78/I1A DC/DC LED Control Evaluation Board* features circuits to perform constant current control of 3 LED channels (RGB LEDs) in order to demonstrate the special 16-bit Timers KBn (n = 0, 1, 2).
 - Buck topology
 - 350 mA maximum current per channel
 - 4 types of dimming control interface supported
 - 3 ch. analog volume control interface (for standalone evaluation)
 - DALI protocol communication interface
 - DMX512 protocol communication interface
 - IR remote control interface
- Easy to use device demonstration capabilities
RL78/I1A DC/DC LED Control Evaluation Board contains elements to easily demonstrate simple I/O-functions (i.e. LED output, I/O lines, UART serial interface) together with the other key functions such as Real Time Clock (RTC), ADC and Timers.
- Power supply via 5V DC connector
RL78/I1A DC/DC LED Control Evaluation Board is powered via a 5V DC jack connector. This power supply is used to power the RL78/I1A as well as the LEDs. When On-Board debug function is used, the USB interface is used to power the μ PD78F7030 78K0 USB microcontroller.
- On-Board debug function
RL78/I1A DC/DC LED Control Evaluation Board supports an On-Board debug function by using the IAR C-SPY debugger, without the need of additional debug hardware. It allows flash programming and supports standard debug functions such as code execution, single stepping, software breakpoints, memory manipulation etc. (The E1 emulator can also be used for on-chip debugging)
- WriteEZ5, Flash programming software
 Windows based Flash programming software allows the user to select and download application programs to the *RL78/I1A DC/DC LED Control Evaluation Board* for evaluation purposes via USB.
- Applilet EZ for HCD Controller, Automated software generation tool
 Software tool used to generate full projects for different compilers.

- Various input / output signals available, such as
 - All I/O ports prepared to be connected to user hardware
 - Virtual UART interface, via the μ PD78F0730 78K0 8-bit microcontroller with on-board USB interface
- The IAR Embedded Workbench for RL78 and the IAR C-SPY debugger are included. These packages are restricted in such that maximum program code size is limited to 16 Kbytes.
- Full documentation is included for the Renesas software tools and the RL78/I1A device.

1.2 System requirements

HOST PC	<p>A PC supporting Windows XP, Windows Vista or 7 is required for the development tools installation. A Pentium processor with at least 1 GHz CPU performance, with at least 256 Mbytes of RAM, allowing you to fully utilize and take advantage of the product features. 350 Mbytes of free disk space and an additional 10 Mbytes of free disk space on the Windows system drive.</p> <p>A web browser and Adobe Acrobat Reader to be able to access all the product documentation.</p>
Host interface	USB interface that enables communication based on USB (Ver1.1 or later)

1.3 Package contents

Please refer to the Package Contents List supplied with the product.

If any part is missing or seems to be damaged, please contact the dealer from whom you received your *RL78/I1A DC/DC LED Control Evaluation kit*.

Chapter 2 System Configuration

The *RL78/I1A DC/DC LED Control Evaluation Board* system configuration is given in the diagram below:

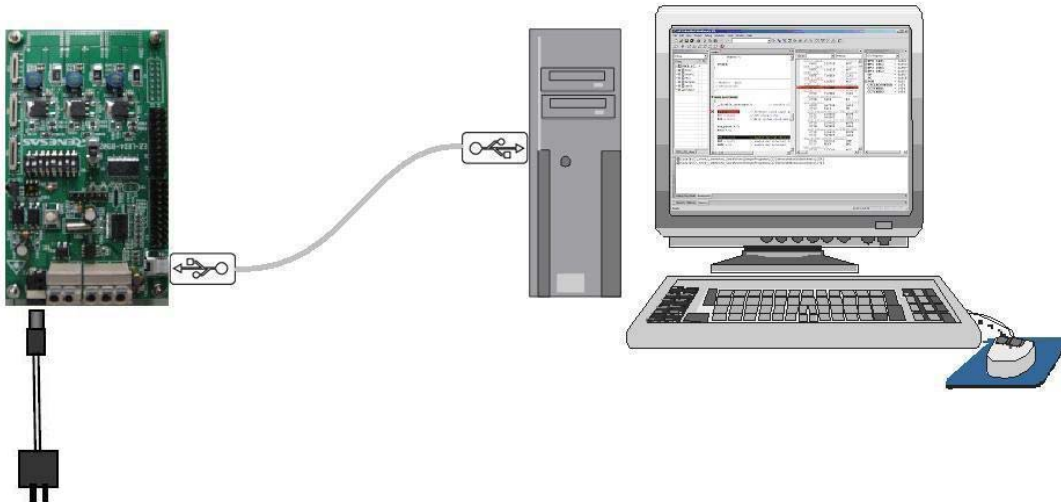

Figure 1: *RL78/I1A DC/DC LED Control Evaluation Board* System Configuration

2.1 RL78/I1A DC/DC LED Control Evaluation Board

RL78/I1A DC/DC LED Control Evaluation Board is a demonstration board for evaluating the new Renesas RL78/I1A family of devices. The device used is the RL78/I1A (R5F107DEG). The board can be directly connected to the host system via a USB port. The host system may be used for On-Board debugging or Flash programming and to allow execution of the Demonstration program on the RL78/I1A device.

As default, the RL78/I1A is using the 32 MHz internal high-speed oscillator, but the *RL78/I1A DC/DC LED Control Evaluation Board* is provided with a connection for an external 20 MHz oscillator (not fitted) if the user wishes to use a different clock frequency than that provided by the internal high speed oscillator. An external low power 32.768 KHz resonator is provided for the sub-clock.

2.2 Host Computer

The USB host interface enables communication to the *RL78/I1A DC/DC LED Control Evaluation Board*. The μ PD78F0730 78K0 8-bit microcontroller with on-chip USB interface and the Renesas Electronics virtual UART driver allows application software to access the USB device in the same way as it would access a standard RS232 interface. The Renesas Electronics virtual UART driver appears to the windows system as an extra Com Port, in addition to any existing hardware Com Ports.

2.3 Power Supply

RL78/I1A DC/DC LED Control Evaluation Board is powered by a 5V DC power supply and also by USB interface when the μ PD78F0730 78K0 microcontroller is to be used for On-Board debugging, flash programming or virtual UART communication purpose.

Chapter 3 Board Components

The *RL78/I1A DC/DC LED Control Evaluation Board* is equipped with a USB connector and with several connectors in order to be connected to host computers, E1 emulator, DALI or DMX master or any external target hardware.

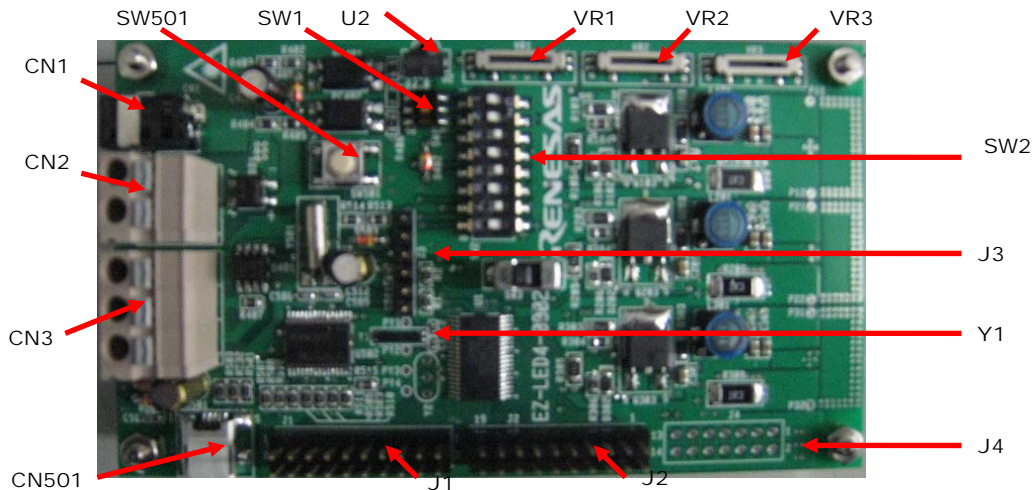

Figure 2: RL78/I1A DC/DC LED Control Evaluation Board Components

Some of the *RL78/I1A DC/DC LED Control Evaluation Board* components are free for user application hardware and software. Please read the User's Manual of the RL78/I1A device carefully to get information about the electrical specification of the available I/O ports before you connect any external signal to the *RL78/I1A DC/DC LED Control Evaluation Board*.

3.1 Configuration Switch SW2

The switch SW2 controls the different operating modes of the *RL78/I1A DC/DC LED Control Evaluation Board*.

3.1.1 Normal Operation Mode

The default operation of the board is set for Normal Operation mode. Switch SW2 should be set as shown in the table below:

Bits	Configuration
1*	OFF
2*	OFF
3	OFF
4	OFF
5	OFF
6	OFF
7	ON
8	ON

Table 1: SW2, Normal Operation Mode

* When DALI or DMX512 communication is to be used, bits 1 and 2 of switch SW2 should both be set to ON position.

3.1.2 On-Board Debug (OCD) Mode / Flash Programming Mode

The *RL78/I1A DC/DC LED Control Evaluation Board* supports on-board debug mode via the USB interface achieved by a dedicated monitor running on the RL78/I1A device. By using the IAR C-SPY debugger, flash programming and standard debug functions i.e. code execution, single stepping, software breakpoints, memory manipulation etc. are supported.

Additionally the built-in Flash memory of the RL78/I1A device can be re-programmed by using the WriteEZ5 Flash programming GUI. Configure switch SW2 as following to use the on-board debug or Flash programming mode:

Bits	Configuration
1*	OFF
2*	OFF
3	ON
4	OFF
5	ON
6	OFF
7	ON
8	OFF

Table 2: SW2, On-Board Debug / Flash Programming Mode

* When DALI or DMX512 communication is to be used, bits 1 and 2 of switch SW2 should both be set to ON position.

3.1.3 E1 On-Chip Debug Mode

The *RL78/I1A DC/DC LED Control Evaluation Board* also supports on-chip debug mode via the E1 emulator. When using the E1 emulator for on-chip debugging, the board can either be powered from the emulator or from the 5V DC power supply.

Bits	Configuration
1*	OFF
2*	OFF
3	OFF
4	OFF
5	OFF
6	OFF
7	ON
8	ON

Table 3: SW2, E1 On-Chip Debug Mode

* When DALI or DMX512 communication is to be used, bits 1 and 2 of switch SW2 should both be set to ON position.

3.1.4 Virtual UART Mode

The *RL78/I1A DC/DC LED Control Evaluation Board* supports Virtual UART mode via the μ PD78F0730 78K0 8-bit microcontroller. Switch SW2 should be set as shown in the table below:

Bits	Configuration
1*	OFF
2*	OFF
3	OFF
4	ON
5	OFF
6	ON
7	ON
8	ON

Table 4: SW2, Virtual UART Mode

* When DALI or DMX512 communication is to be used, bits 1 and 2 of switch SW2 should both be set to ON position.

3.2 Configuration Switch SW1

The switch SW1 selects the lighting communication protocol to be used by the *RL78/I1A DC/DC LED Control Evaluation Board*.

When using DALI or DMX512 communication, please don't forget to set bits 1 and 2 of switch SW2 to ON position.

Configuration	Function
1-2 & 4-5	DALI
3-2 & 6-5	DMX512

Table 5: SW1, Lighting Communication Protocol Selection

3.3 Configuration Switch SW3

The switch SW3 selects the IR remote control channel. Two different channels can be selected on the *RL78/I1A DC/DC LED Control Evaluation Board*, CH1 corresponds to a 0x5AA5 data code, and CH2 to a 0xDA25 data code.

Configuration	Function
CH1	Custom code: 0x0000+Data code: 0x5AA5
CH2	Custom code: 0x0000+Data code: 0xDA25

Table 6: SW3, IR Remote Control Channel Selection

3.4 Reset Switch SW501

The switch SW501 is the reset switch of the *RL78/I1A DC/DC LED Control Evaluation Board*. It can be used to reset operation during on-board debugging or during normal operation mode.

3.5 External Power Supply CN1

External power is supplied by connecting a regulated 5V DC to the jack connector CN1.

The operation of the board is as follows:

- External supply only (The board can only be operated as stand alone only, no USB power connection).

Or

- External supply and USB power (This configuration should be used when the user intends to use On-Board debugging, flash programming or virtual UART communication via the μ PD78F0730 78K0 8-bit microcontroller).

3.6 DALI Interface Connector CN2

CN2 is the connector for DALI interface. CN2 is a 2-way connector to enable communication with a DALI master via the DALI communication protocol.

3.7 DMX512 Interface Connector CN3

CN3 is the connector for DMX512 interface. CN3 is a 3-way connector to enable communication with a DMX512 master via the DMX512 communication protocol.

3.8 InfraRed Detector U2

InfraRed (IR) detector U2 can be used to enable IR communication between a controller device and the RL78/I1A. The controller device can send commands to the RL78/I1A microcontroller using the IR communication protocol.

3.9 E1 Emulator Connector J4

Connector J4 (not fitted) is provided to allow debugging and programming of the RL78/I1A microcontroller using the E1 OCD emulator. This function allows the user to be able to debug an application and make use of the UART0 serial interface that can use the Renesas Virtual UART to interface to the PC. For this function a 14-way (2 x 7) standard pitch connector needs to be mounted and connected as shown below.

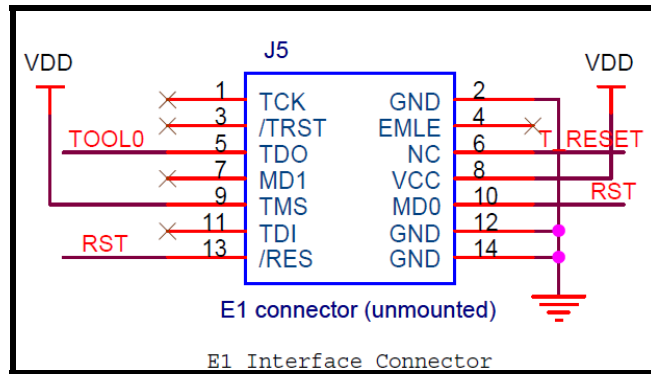

Figure 3: E1 Emulator Connection

3.10 Programming Connector J3

Connector J3 is provided for production programming of the μ PD78F0730 78K0 8-bit microcontroller during manufacturing. The 78K0/USB device should not be reprogrammed.

3.11 Mini-B USB Interface Connector CN501

The mini-B USB connector allows connecting the IDE or the WriteEZ5 Flash programming software to the *RL78/I1A DC/DC LED Control Evaluation Board* in order to debug or program application software to the RL78/I1A device. The power supply for the 78K0/USB device is also provided by this connector.

Additionally connector CN501 connects the UART0 serial interface of the RL78/I1A device to the host system.

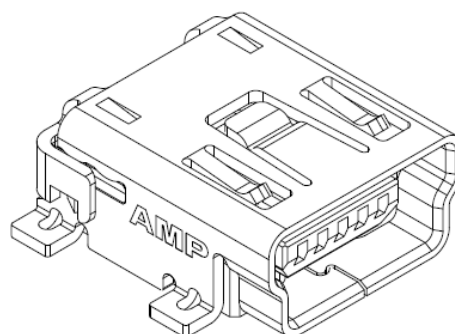

Figure 4: Connector CN501, Mini USB B Type Connector Pin Configuration

USB Connector CN501	Signal Name
1	V_{BUS}
2	D-
3	D+
4	NC
5	GND

Table 7: Pin Configuration of mini-B USB Connector CN501

For connection with the host machine, the *RL78/I1A DC/DC LED Control Evaluation Board* can be plugged directly into an available USB port.

3.12 External Connectors J1 and J2

J1 to J2 are connectors for external user hardware. Standard 0.1" pitch, 10-way double row, straight headers are mounted to bring all I/Os for usage. Please read the User's Manual of the RL78/I1A device carefully to get information about the electrical specification of the available I/O ports.

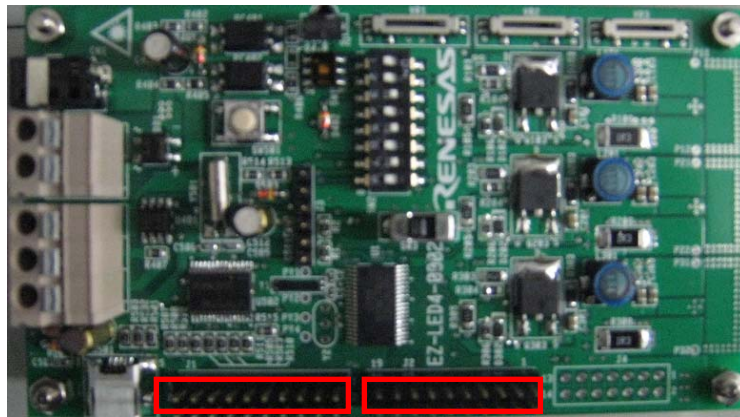

Figure 5: External Connectors J1 and J2

J1	Signal Name	RL78/I1A Pin Name	Comment
1	P20	P20/ANI0/AVREFF	Connected to VDD
2	P03	P03/RXD1/CMP5P/ANI16	
3	P02	P02/TXD1/ANI17	
4	P120	P120/ANI19	
5	P40	P40/TOOL0	
6	RESET	RESET	
7	P124	P124/XT2/EXCLKS	
8	P123	P123/XT1	
9	P137	P137/INTP0	
10	P122	P122/X2/EXCLK	
11	P121	P121/X1	
12	REGC	REGC	
13	VSS	VSS	
14	VDD	VDD	
15	P31	P31/TI03/TO03/INTP4	
16	P77	P77/INTP11	
17	P76	P76/INTP10	
18	P61	P61/SDAA0	
19	P75	P75/INTP9	
20	-	-	No connection

Table 8: Connector J1

J2	Signal name	RL78/G13 Pin Name	Comment
1	P21	P21/ANI1/AVREFM	Connected to VSS
2	P22	P22/ANI2/CMP0P	
3	P24	P24/ANI4/CMP1P	
4	P25	P25/ANI5/CMP2P	
5	P26	P26/ANI6/CMP3P	
6	P27	P27/ANI7/CMP4P	
7	P147	P147/CMPCOM/ANI18	
8	P10	P10/SO00/TXD0/TKCO00/INTP20/SCLA0/(DALITxD4)	
9	P11	P11/SI00/RXD0/TKCO01/INTP21/SDAA0/(TI07)/(DALIRxD4)/(TxRx4)	
10	P12	P12/_SCK00/(TKCO03)	
11	P200	P200/TKBO00/INTP22	
12	P201	P201/TKBO01	
13	P202	P202/TKBO10/(INTP21)	
14	P203	P203/TKBO11/TKCO02/(INTP20)	
15	P204	P204/TKBO20/TKCO03	
16	P205	P205/TKBO21/TKCO04/DALITxD4	
17	P206	P206/TKCO05/DALIRxD4/txRx4/INTP23	
18	P30	P30/INTP3/RTC1HZ	
19	P05	P05/TI05/TO05	
20	-	-	No connection

Table 9: Connector J2

3.13 Low Power 32 KHz Resonator Y1

The *RL78/I1A DC/DC LED Control Evaluation Board* is fitted with an external 32 KHz resonator (Y1) characterized specifically for the RL78 devices supplied by Seiko Instruments Inc.

This is a specially designed low power resonator designed to support the very low power consumption of the RL78 family.

3.14 RL78/I1A Memory Map

The RL78/I1A memory layout is shown in the table below.

Address area	0xFFFF	SFR Area 256 bytes	Free for user application software	
	0xFFF00			
	0xFFE00	Internal RAM 4KB		
	0xFFF00			
	0xFFE00	Mirror 51.75 KB		
	0xF2000			
	0xF1FFF			
	0xF1000	Data flash memory 4 KB		
	0x0F0FFF	Access prohibited area		
	0xF0800			
	0x0F07FF			
	0xF0000	2nd SFR 2 KB		Free for user application software
	0xE0000	Access prohibited area		
	0x10000			
	0x0FFFF			
	0x00000	64 KB code flash memory		Free for user application software

Table 10: RL78/I1A Memory Map

Chapter 4 Getting Started

The default setting of the *RL78/I1A DC/DC LED Control Evaluation Board* is set for demonstration of LED constant current control and dimming control using on-board variable resistors. The *RL78/I1A DC/DC LED Control Evaluation Board* comes already flash programmed with the LED control sample program.

The Quick Start Guide supplied in printed form and on the CD as a PDF file will take the user through the software installation procedure.

4.1 Installed Contents

The CD has a file called `versions.txt` in the root, this confirms the exact software components and versions installed.

Chapter 5 Hardware Installation

After unpacking the *RL78/I1A DC/DC LED Control Evaluation Board*, connect the supplied USB cable to the board.

This driver must be installed before the user can use the debugger, to do this, just install the software supplied; please refer to the accompanying Quick Start guide (D011299-11

Chapter 6 Software Installation

Please refer to the accompanying Quick Start guide (D011299-11) also found on the Software CD for instructions on how to install the software for this product.

Chapter 7 How to Use WriteEZ5 Flash Programming Software

This chapter explains the basic operations of the WriteEZ5 GUI for programming the *RL78/I1A DC/DC LED Control Evaluation Board*. This chapter covers how to start the system, execute the EPV command (Erase, Program, Verify), and program the target RL78/I1A device.

The conditions of the series of operations described in this chapter are as follows:

Hardware Configuration of RL78/I1A DC/DC LED Control Evaluation Board	Board:	<i>RL78/I1A DC/DC LED Control Evaluation Board</i>
	CPU:	RL78/I1A
	Target Device:	R5F107DE
	Voltage level:	5 V

Software Configuration of WriteEZ5 GUI	Parameter file:	R5F107DE.pr5
	Clock setting:	Internal-OSC
	Port:	COMxx (115200bps)
	Operation mode:	Chip
	Write HEX file:	*.hex
	Option Setting:	Blank check before Erase

- <1> **Installing the WriteEZ5 GUI** Running the Software CD installation supplied with this product will automatically deploy the correct software.
- <2> **Installing the driver** Running the Software CD installation supplied with this product will automatically deploy the correct software.
- <3> **Installing the parameter files** Running the Software CD installation supplied with this product will automatically deploy the correct software.
- <4> **Setting and connecting** Set the *RL78/I1A DC/DC LED Control Evaluation Board* by configuring switch SW2 as following:

Bits	Configuration
1	OFF
2	OFF
3	ON
4	OFF
5	ON
6	OFF
7	ON
8	OFF

Table 11: SW2, Configuration for Flash Programming Mode

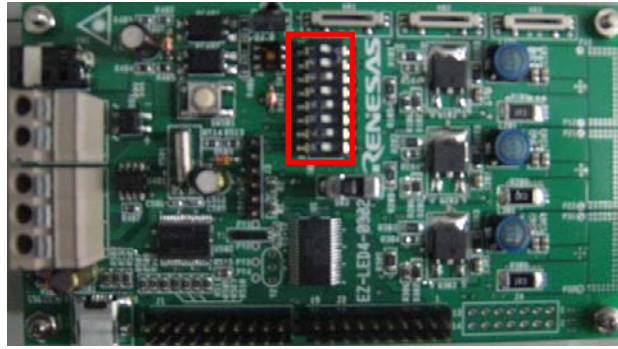

Figure 6: SW2 for Mode Configuration

Connect the *RL78/I1A DC/DC LED Control Evaluation Board* with the host machine.

<5> **Starting** Start the WriteEZ5 GUI from the start menu:

[Start] → [All Programs] → [Renesas Electronics Tools] → [WriteEZ5]

Or use the shortcut icon on your Desktop.

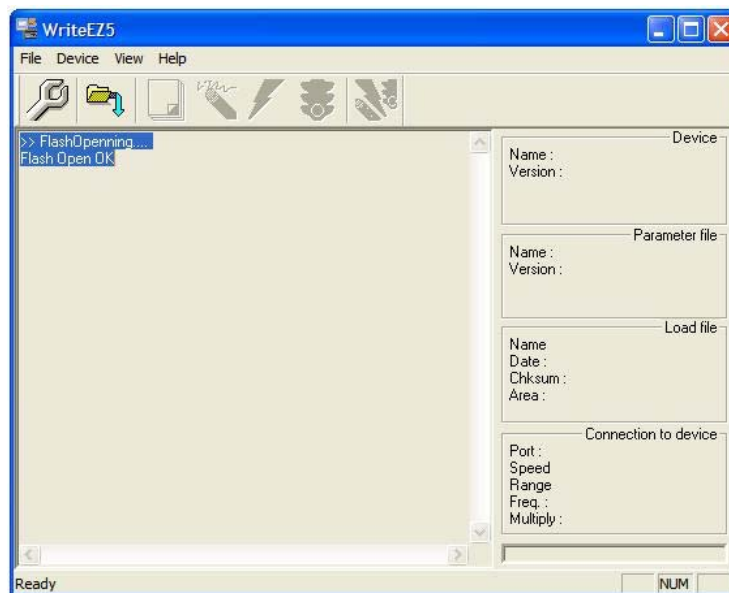

Figure 7: WriteEZ5 Start-up Screen

<6> **Setting the programming environment** (6.1) Select [Device] → [Setup] from the menu bar or click on the [Setup] icon. The “Standard” tab of the “Device Setup” dialog box is opened:

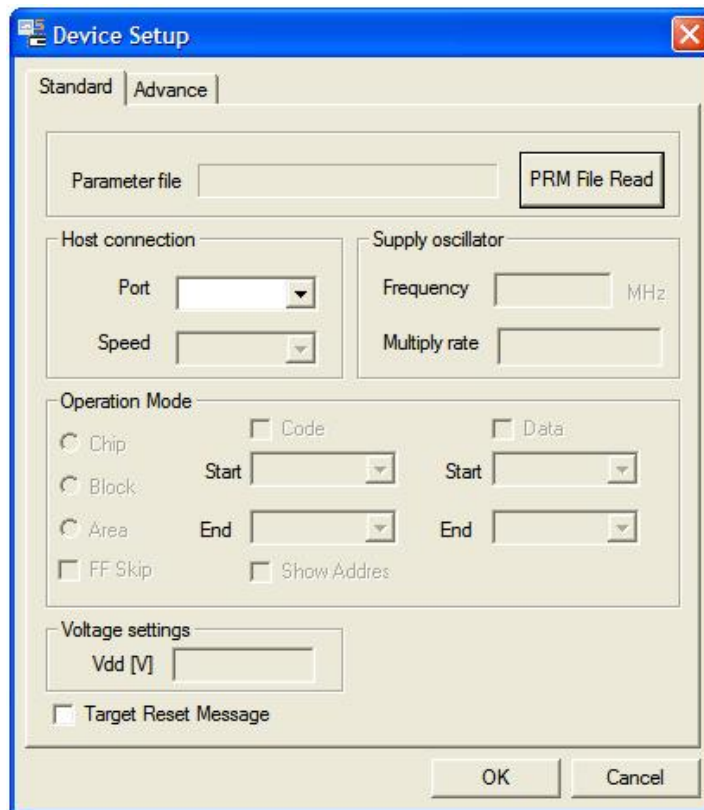

Figure 8: Standard Device Setup Dialog Box

(6.2) Click on **PRM File Read** to open the parameter file selection window. Select the parameter file “R5F107DE.pr5”, and then click **Open**.

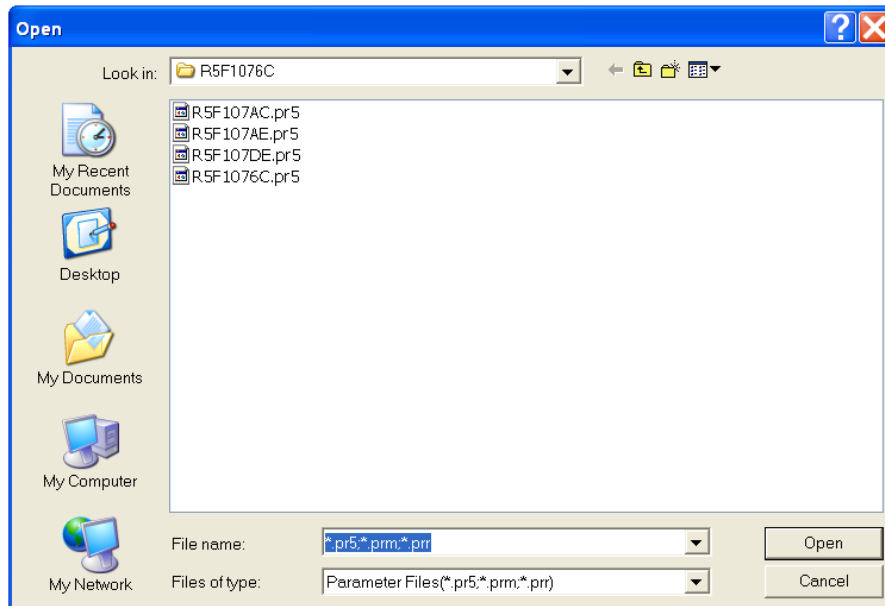

Figure 9: Parameter File Selection

(6.3) From the “Port” list box, select the communication port that matches the host machine being used. Select the communication speed of the host connection.

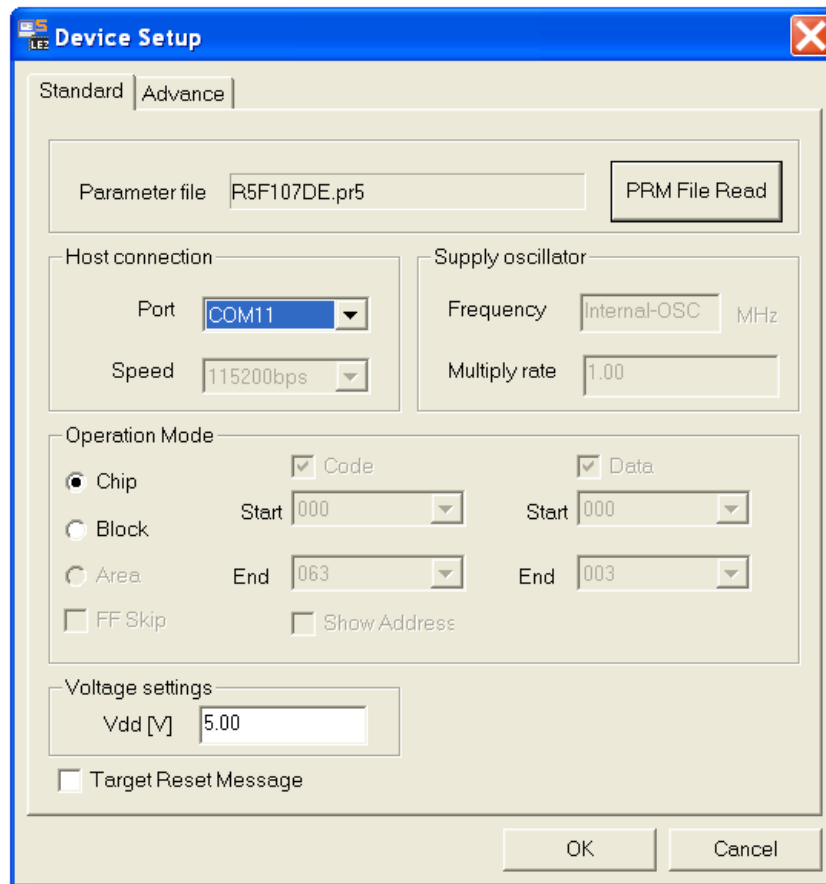

Figure 10: Port Selection

Remark Selectable ports can be checked using Device Manager. The user must have installed the software first.

(6.5) Switch to the “Advance” dialog box:

In “Command Options”, check “Blank check before Erase”.

In “Security flag settings”, all the different options should remain unchecked.

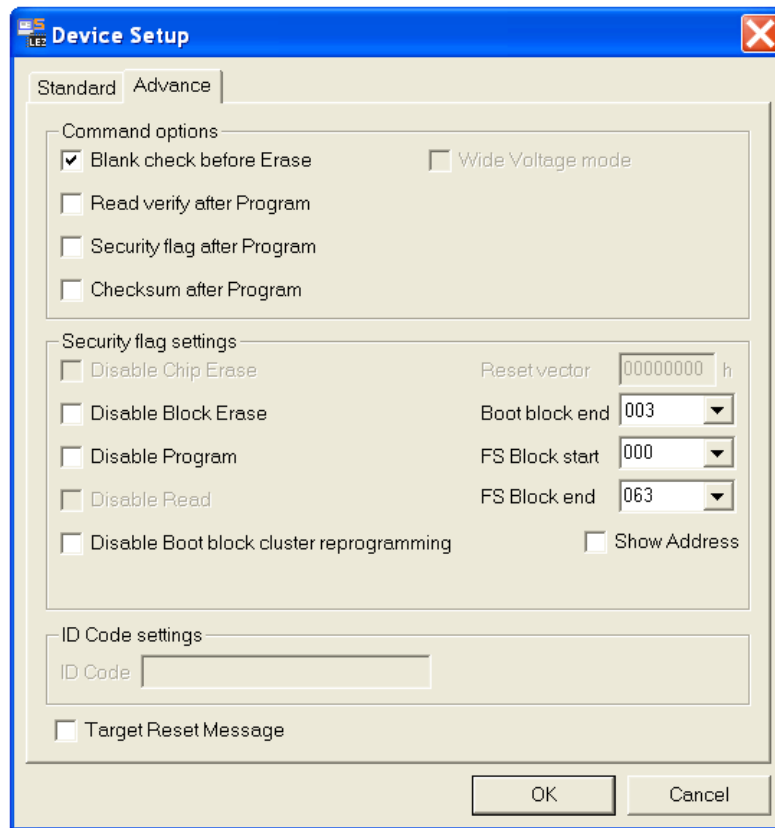

Figure 11: Advance Device Setup Dialog Box

(6.6) Click on the button **OK**. The GUI software sets the parameters.

When the settings have been completed, the following screen is displayed:

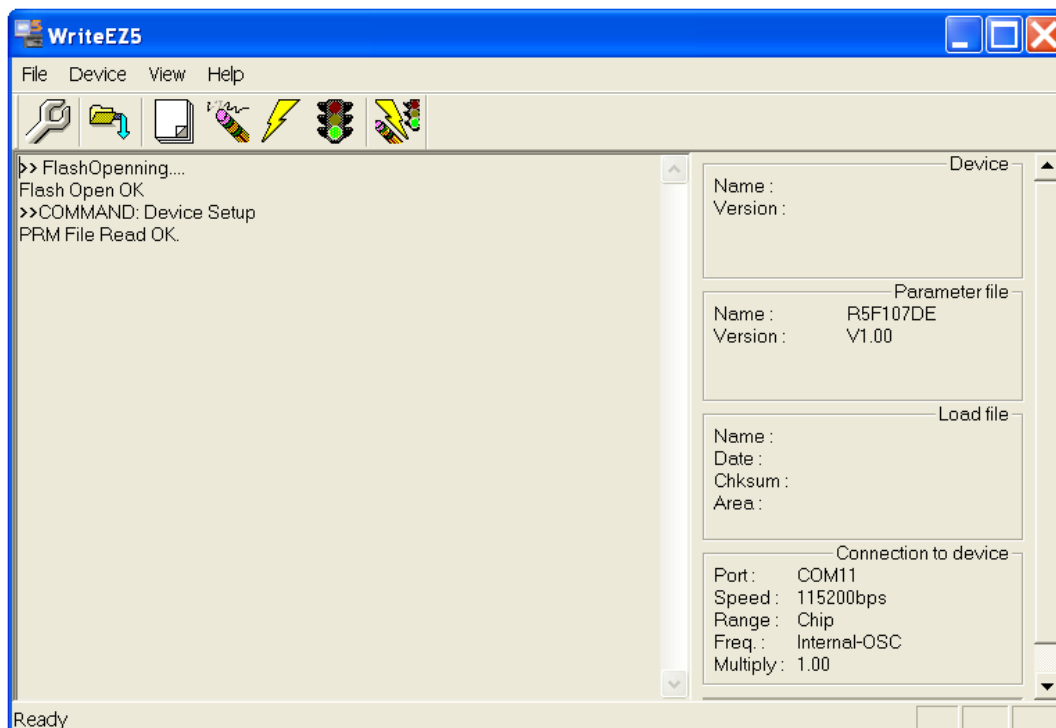

Figure 12: Completion of Parameter Settings

- <7> **Selecting a user program** (7.1) Select [File] → [Load] from the menu bar or click on the [Load] icon.
- (7.2) Select a program file to be written to the target device, then click on the button **Open**.

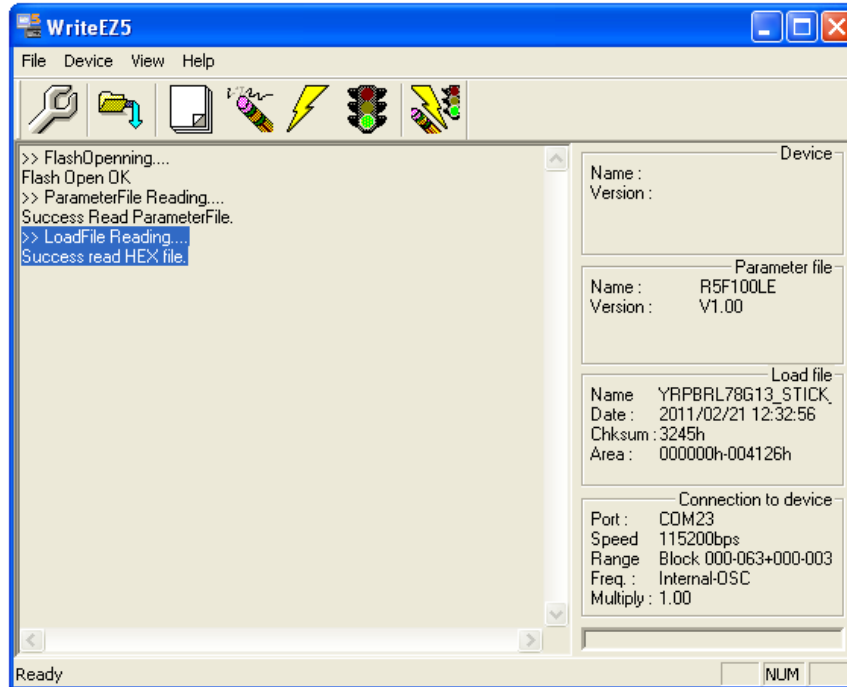

Figure 13: Completion of HEX File Download

- <8> **Auto procedure (EPV) command execution** Select [Device] → [Autoprocedure(EPV)] from the menu bar or click on the [Autoprocedure] icon.
- When the [Autoprocedure(EPV)] command is executed, Blank Check → Erase → Program and Flash Internal Verify are executed sequentially for the RL78/I1A device.

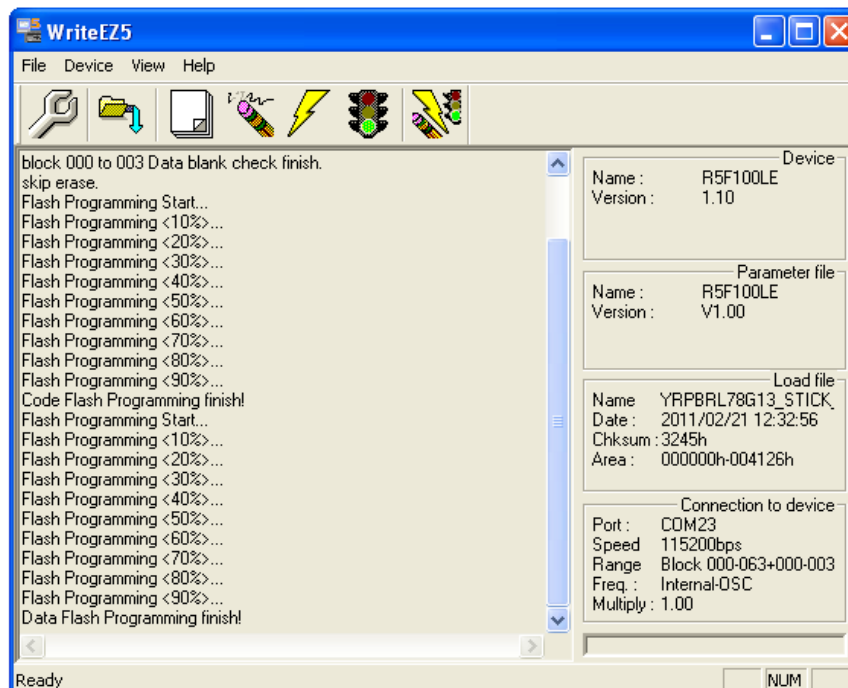

Figure 14: Completion of EPV Command

<9> **Terminating the GUI** Select [File] → [Quit] to terminate the GUI software. All settings executed are saved, so that those settings can be reused when the WriteEZ5 GUI is restarted.

<10> **Execute application** Set the *RL78/I1A DC/DC LED Control Evaluation Board* to the normal operation mode by applying the following settings.

Bits	Configuration
1	OFF
2	OFF
3	OFF
4	OFF
5	OFF
6	OFF
7	ON
8	ON

Table 12: SW2, Configuration for Normal Operation Mode

<11> **Restarting the GUI** When the WriteEZ5 GUI is restarted, the latest settings should be applied.

Chapter 8 Applilet EZ for HCD Controller

Applilet EZ for HCD Controller is a software tool used to automatically generate software code for the RL78/I1A microcontroller (and also for the 78K0/Ix2), which is used to control the LED current.

Software can be easily generated by specifying the setting and operation of the RL78/I1A on the GUI. The generated software can be directly written into the flash memory of the RL78/I1A microcontroller via a USB cable and the operation can be performed and checked by using the *RL78/I1A DC/DC LED Control Evaluation Board*.

By using Applilet EZ for HCD Controller, a digital RL78/I1A-based lighting system can be designed without requiring a detailed knowledge of complex programming languages. Furthermore, microcontroller software development, which can usually take a certain amount of time, and operation evaluation can be significantly reduced.

For further information please refer to the “Applilet EZ for HCD Controller User’s Manual” which can be found on the Renesas website.

8.1 General Settings

This section will go through the different Applilet EZ for HCD Controller’s general settings.

<1> Open Applilet EZ for HCD Controller.

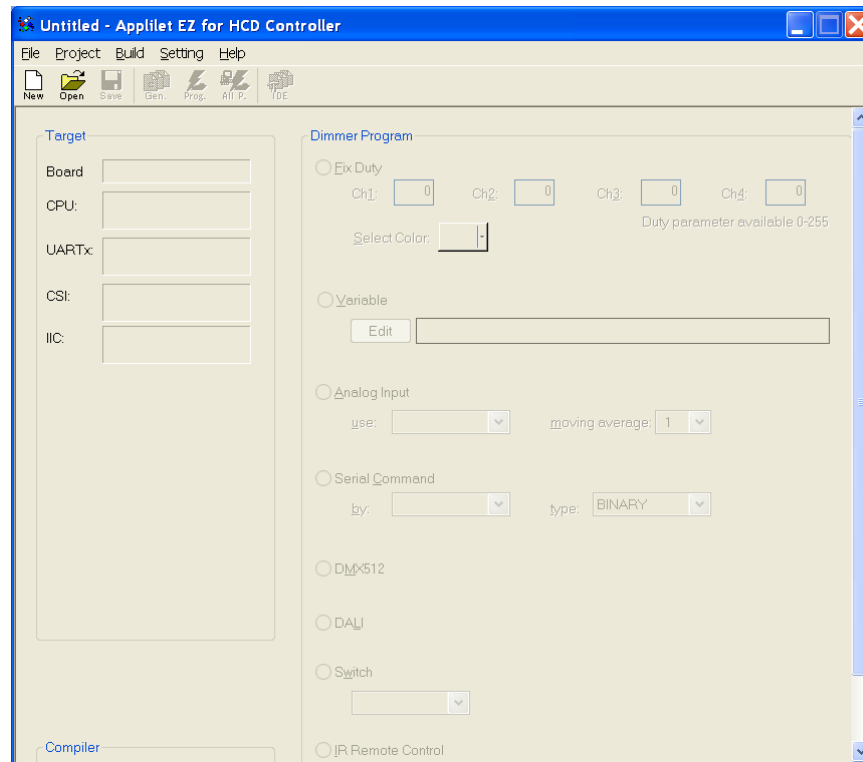

Figure 15: Applilet EZ for HCD Controller Main Window

- <2> Under the **Project** menu all of the MCU settings will be listed for configuration, select **CPU** or simply press the “**New**” button.

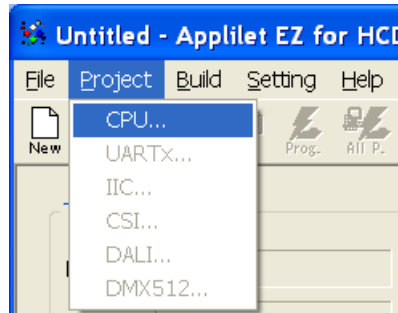

Figure 16: Applilet EZ for HCD Controller New Project

- <3> In the CPU settings, select Target to **EZ-0012** board.

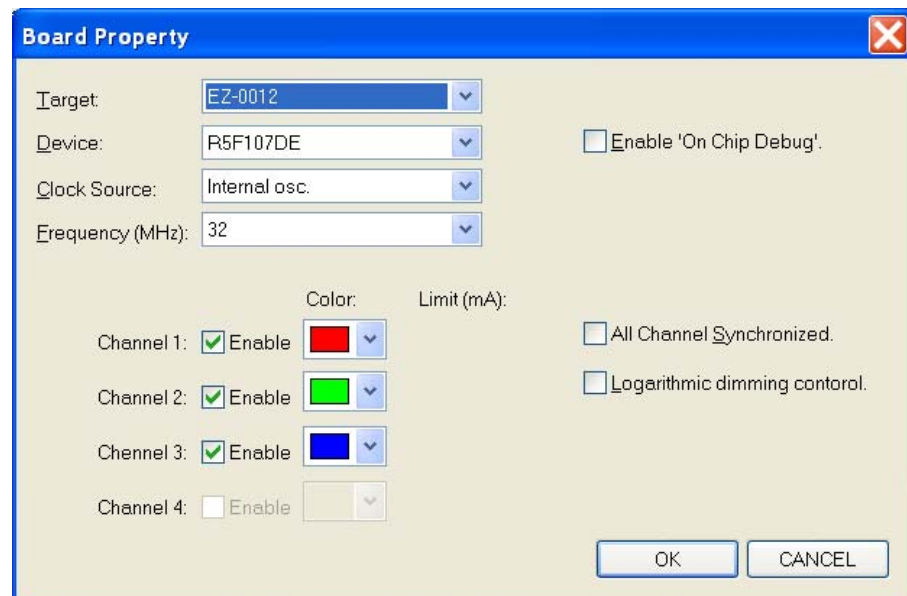

Figure 17: Applilet EZ for HCD Controller CPU Settings

- <4> The Applilet EZ tool is able to generate code and projects for different compilers, one of them is the IAR compiler. Select it by clicking on the **Setting** menu, then **Select Compiler** and choose the **IAR** compiler.

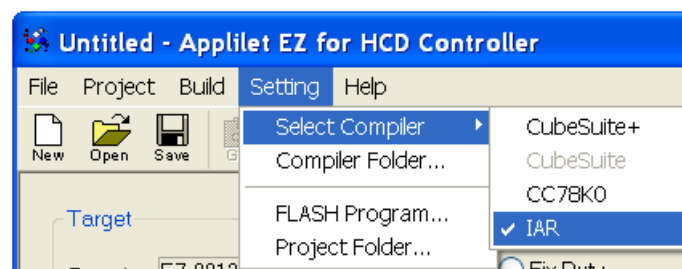

Figure 18: Applilet EZ for HCD Controller Compiler Selection

Note Make sure that you have installed the selected compiler correctly to your host PC before building the project.

<5> It is also possible to configure the output project folders by clicking on the **Setting** menu and then selecting **Project Folder**.

These locations will specify the output paths of the generated files. Enter in your desired destination but please keep in mind that Applilet EZ will then create subdirectories under this folder for each Applilet EZ project. Click **OK**.

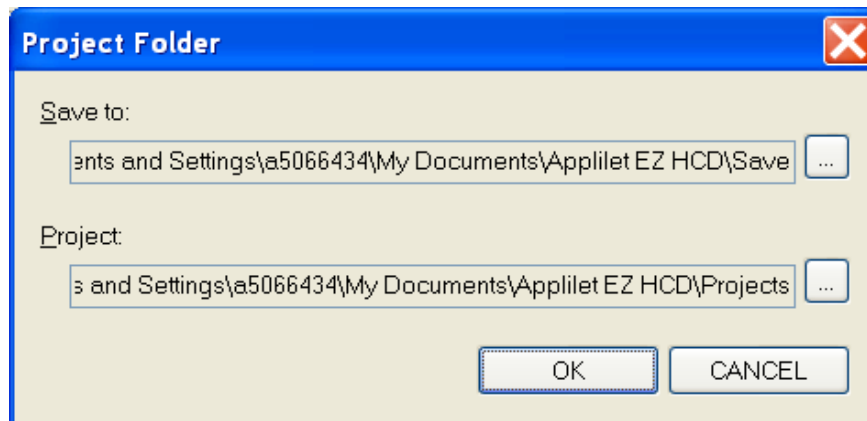

Figure 19: Applilet EZ for HCD Controller Project Folder

8.2 Fix Dimmer Program

This program sets a fixed duty value for each of the 3 LED channels. Make sure that all settings explained previously are still correctly set before proceeding with the following steps.

<1> Make sure "**Fix Duty**" is still selected as the dimmer program.

<2> Input "**128**" to all the channels so they are not too bright.

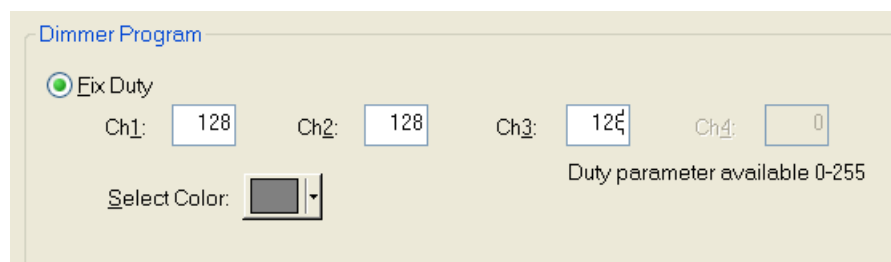

Figure 20: Applilet EZ for HCD Controller Fix Duty Settings

<3> We can then save the new Applilet EZ project (.hcd file). Select the **File** menu, then click on **Save As...** or simply click on the "**Save**" button, and input "**fix.hcd**" for example. To finish click **Save**.

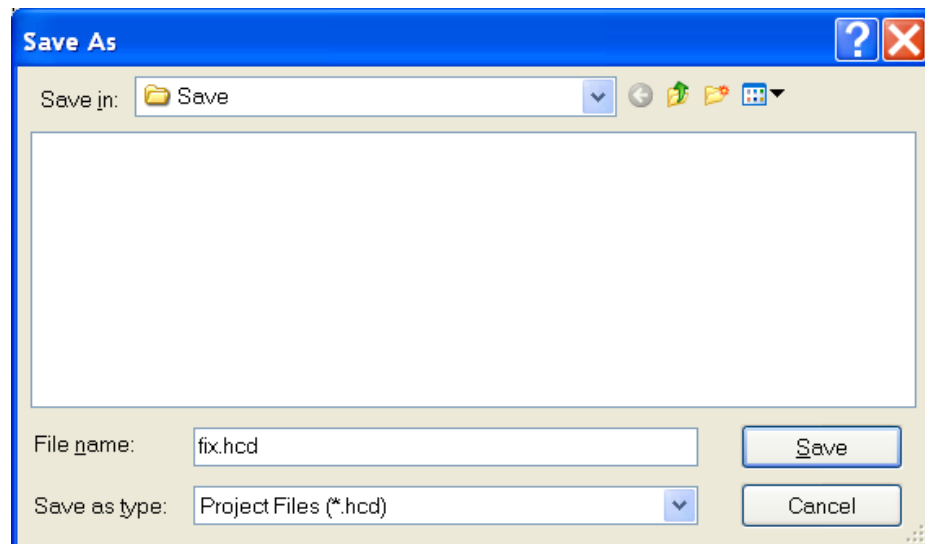

Figure 21: Applilet EZ for HCD Controller Save As Window

- <4> Please make sure to set the SW2 dip switch to the flash programming mode. Then plug the power cable to the *RL78/I1A DC/DC LED Control Evaluation Board*, and plug the USB connector. Click the "All P." button.



Figure 22: Applilet EZ for HCD Controller All Program Button

- <5> You will be informed about the progress of the compilation.

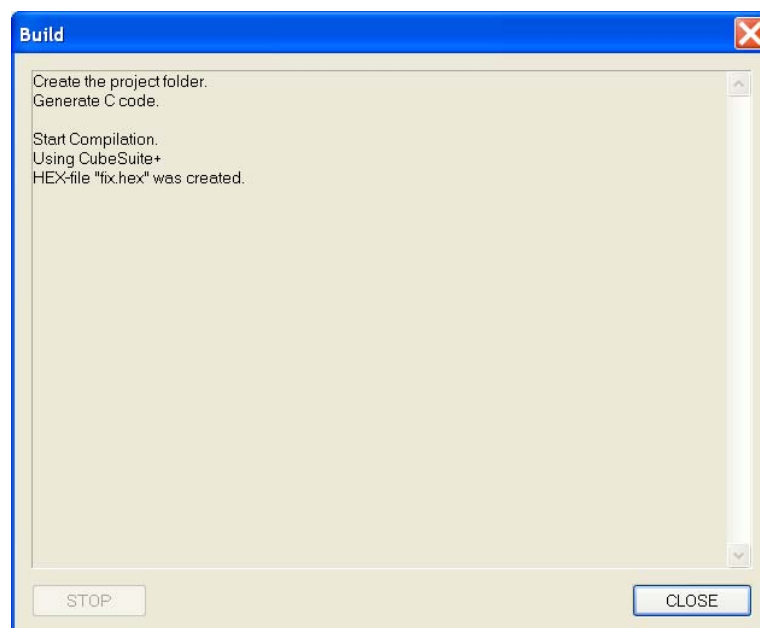

Figure 23: Applilet EZ for HCD Controller Compilation Progress

<6> Next click **OK** when prompt to start flash programming.

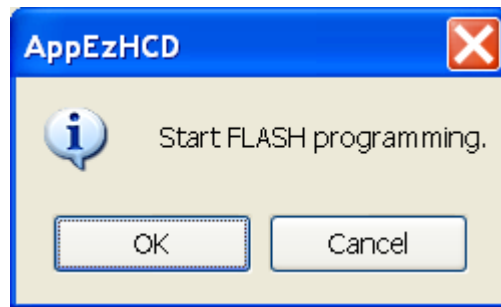

Figure 24: Applilet EZ for HCD Controller Start Flash Programming

<7> During the flash programming procedure you will be informed about the actual status of the programming.

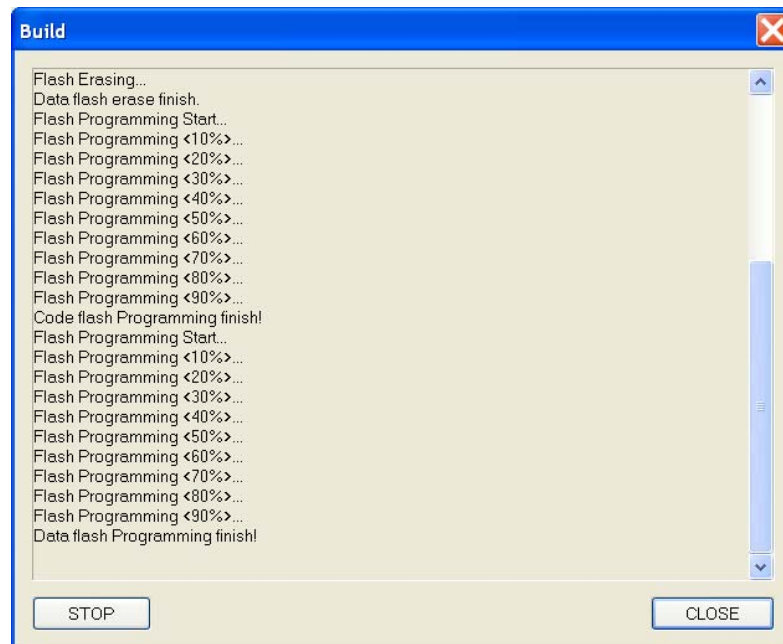

Figure 25: Applilet EZ for HCD Controller Flash Programming Status

<8> Click **CLOSE** to exit the “Build” window. Remove the USB cable and the power supply cable, and change the SW2 dip switch positions to the normal operation mode. Plug the power supply cable to the board connector again and you should see the LEDs light up according to the duty values set earlier.

LED channel 1 = Red
LED channel 2 = Green
LED channel 3 = Blue

8.3 Variable Dimmer Program

This program sets the duty value for each channel according to a drawing pattern data.

- <1> Make sure that you have set all the settings as explained in the *8.1 General Settings* section.
- <2> Save the new Applilet EZ project (.hcd file). Select the **File** menu, then click on **Save As...** or simply click on the “**Save**” button, and input “**variable.hcd**” for example. To finish click **Save**.

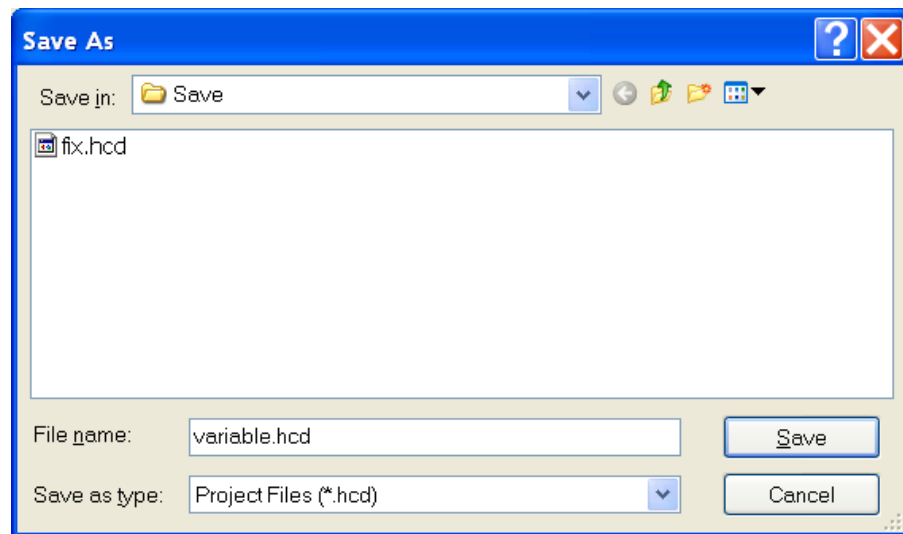

Figure 26: Applilet EZ for HCD Controller Save As Window

- <3> We now have a new Applilet EZ project file and we will change the dimmer program to Variable.



Figure 27: Applilet EZ for HCD Controller Dimmer Program Selection (Variable)

- <4> Click on the “**Edit**” button under “Variable” and the “Dimmer Programming” window will open. Enable the “**Cyclic**” check box. Click the “**Ch.1**” button to select this channel for modification. Select the line mode as shown below. This will allow you to draw the PWM duty cycle versus time by using your mouse pointer.

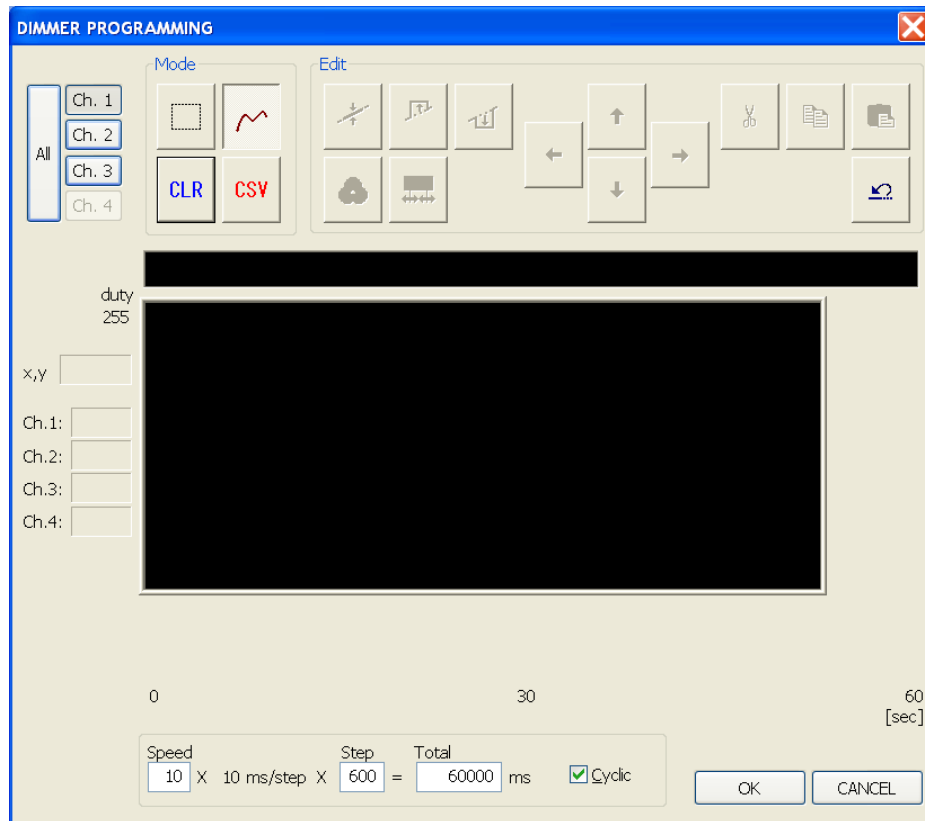

Figure 28: Applilet EZ for HCD Controller Dimmer Programming (Variable)

<5> Draw something close to the sinusoidal wave below and then click **OK**.

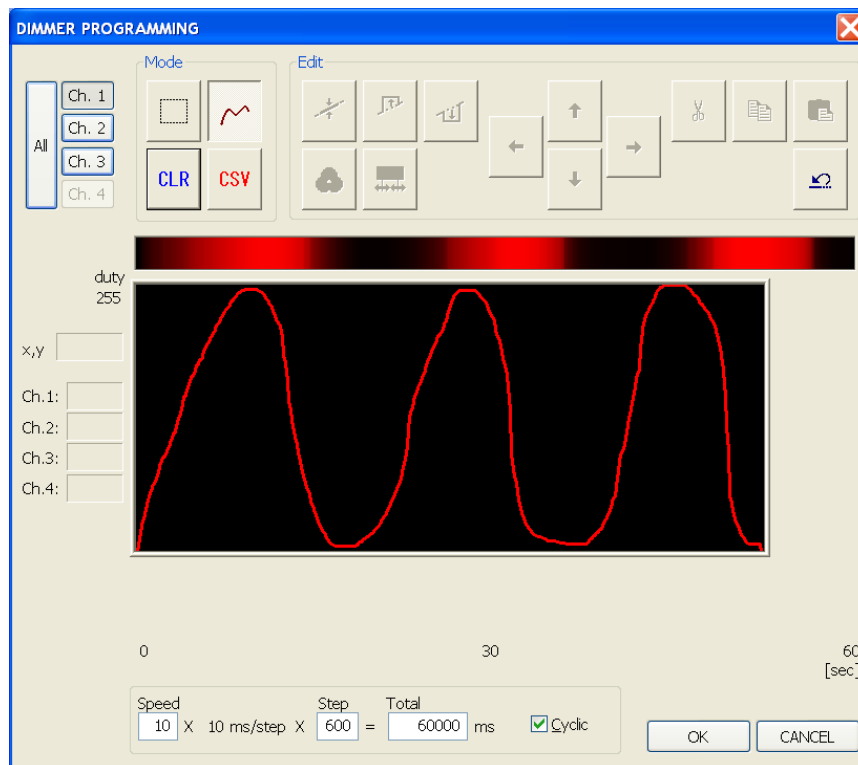

Figure 29: Applilet EZ for HCD Controller Wave Editor (1 channel)

- <6> Repeat the same process for the two other channels. Then click on the **OK** button to exit the variable dimmer control window.

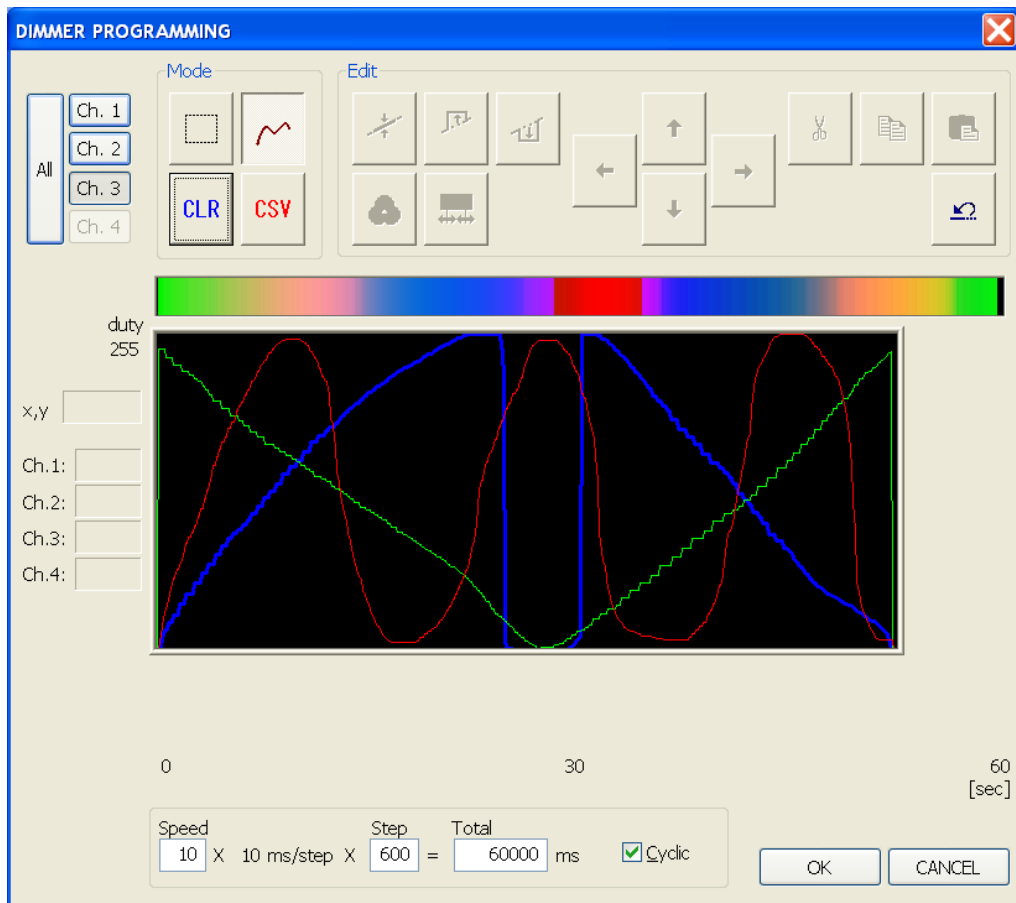

Figure 30: Applilet EZ for HCD Controller Wave Editor (3 channels)

- <7> Make sure that SW2 dip switch of the *RL78/I1A DC/DC LED Control Evaluation Board* is in flash programming mode, and that the USB and power supply cables are connected correctly. Click the **“Save”** button and then the **“All P.”** button. After downloading the application, please disconnect the USB and power supply cables and set the board to the normal operation mode.
- <8> Plug again the DC 5V power supply, and you should now see the on-board LEDs running the variable dimming application based on the above wave form.

8.4 Analog Input Dimmer Program

This program sets the duty value for each channel according to the on-board variable resistors values read from the A/D converter.

- <1> Make sure that you have set all the settings as explained in the *8.1 General Settings* section.

- <2> Save the new Applilet EZ project (.hcd file). Select the **File** menu, then click on **Save As...** or simply click on the “**Save**” button, and input “**analog.hcd**” for example. To finish click **Save**.
- <3> We now have a new Applilet EZ project file and we will change the dimmer program to Analog Input.



Figure 31: Applilet EZ for HCD Controller Dimmer Program Selection (Analog)

- <4> Make sure that SW2 dip switch of the *RL78/I1A DC/DC LED Control Evaluation Board* is in flash programming mode, and that the USB and power supply cables are connected correctly. Click the “**Save**” button and then the “**All P.**” button. After downloading the application, please disconnect the USB and power supply cables and set the board to the normal operation mode.
- <5> Plug again the DC 5V power supply, and you should now see the on-board LED brightness changing according to the actions applied to the variable resistors (VR1, VR2 and VR3).

8.5 DMX512 Dimmer Program

This sample shows how to set up Applilet EZ to program the DM512 stack into the R5F107DEG assembled to the *RL78/I1A DC/DC LED Control Evaluation Board*.

- <1> Make sure that you have set all the settings as explained in the *8.1 General Settings* section.
- <2> Save the new Applilet EZ project (.hcd file). Select the **File** menu, then click on **Save As...** or simply click on the “**Save**” button, and input “**dmx512.hcd**” for example. To finish click **Save**.
- <3> We now have a new Applilet EZ project file and we will change the dimmer program to DMX512.



Figure 32: Applilet EZ for HCD Controller Dimmer Program Selection (DMX512)

- <4> Open the “DMX512 Property” dialogue box by selecting the **Project** menu and clicking on **DMX512...** or simply by clicking on the “**Setting**” button. Check that the settings are as shown below.

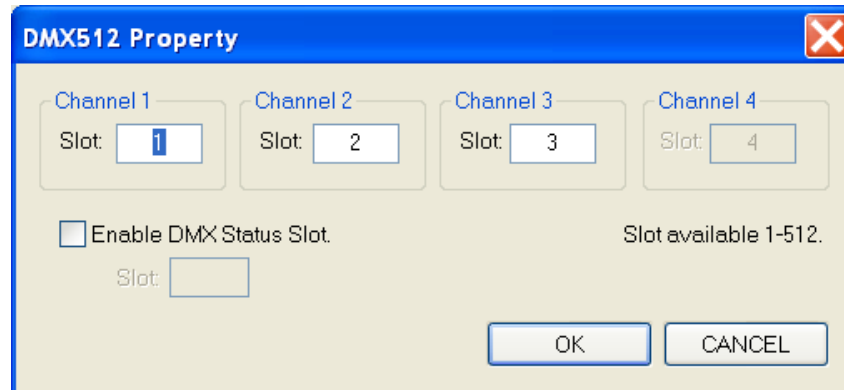

Figure 33: Applilet EZ for HCD Controller DMX512 Property Dialogue Box

- <5> Make sure that SW2 dip switch of the *RL78/I1A DC/DC LED Control Evaluation Board* is in flash programming mode, and that the USB and power supply cables are connected correctly. Click the “**Save**” button and then the “**All P.**” button. After downloading the application, please disconnect the USB and power supply cables and set the board to the normal operation mode.

You should now be able to control the LEDs on the *RL78/I1A DC/DC LED Control Evaluation Board* via the DMX512 protocol by connecting a DMX512 master device. For example, Renesas Electronics offers the *Lighting Communication Master Evaluation Board (EZ-0008)*. This board can be used as a communication master device supporting DMX512, DALI and IR communications.

- <6> The *RL78/I1A DC/DC LED Control Evaluation Board* can be controlled by this *Lighting Communication Master Evaluation Board* together with a GUI running on the host PC. There is a GUI for DMX512 control and a GUI for DALI control, both GUIs can be downloaded from the Renesas Electronics website.

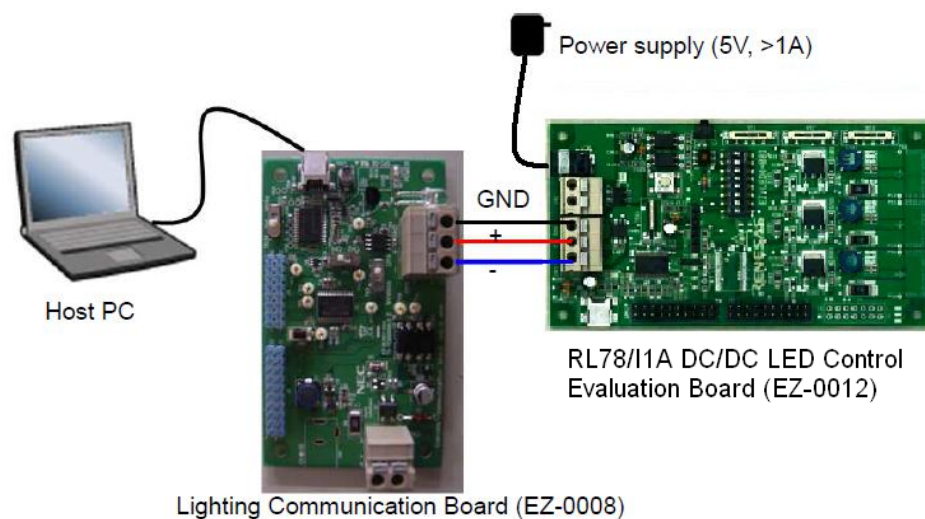

Figure 34: System Configuration for DMX512 Control

- <7> On the *Lighting Communication Master Evaluation Board*, please confirm that SW4 is set to "RUN" and SW3 is set to "DMX".
- <8> Connect the *Lighting Communication Master Evaluation Board* (EZ-0008), via the DMX connector J1, with the *RL78/I1A DC/DC LED Control Evaluation Board* (acting as a DMX512 slave board), via the DMX connector CN3, using the three wires provided.
- <9> Connect the *Lighting Communication Master Evaluation Board* to the host PC using a USB cable.
- <10> Plug the DC 5V power supply cable to the *RL78/I1A DC/DC LED Control Evaluation Board* via connector CN1.
- <11> Send DMX512 commands to the *RL78/I1A DC/DC LED Control Evaluation Board* using the DMX512 Master Controller GUI.

Note To find details about the DMX512 Master Controller GUI, please refer to the corresponding User's Manual (U19596EJ1V0UM00) that can be downloaded from the Renesas Electronics website.

8.6 DALI Dimmer Program

This sample shows how to set up Applilet EZ to program the DALI (Digital Addressable Lighting Interface) stack into the R5F107DEG assembled to the *RL78/I1A DC/DC LED Control Evaluation Board*.

- <1> Make sure that you have set all the settings as explained in the *8.1 General Settings* section.
- <2> Save the new Applilet EZ project (.hcd file). Select the **File** menu, then click on **Save As...** or simply click on the "**Save**" button, and input "**dali.hcd**" for example. To finish click **Save**.
- <3> We now have a new Applilet EZ project file and we will change the dimmer program to DALI.

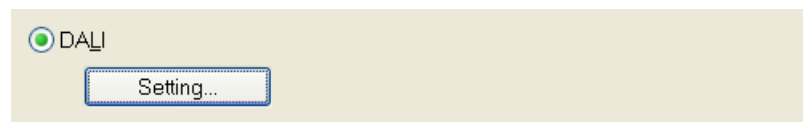

Figure 35: Applilet EZ for HCD Controller Dimmer Program Selection (DALI)

- <4> Open the “DALI Property” dialogue box by selecting the **Project** menu and clicking on **DALI...** or simply by clicking on the **“Setting”** button. Choose the appropriate settings for your evaluation.

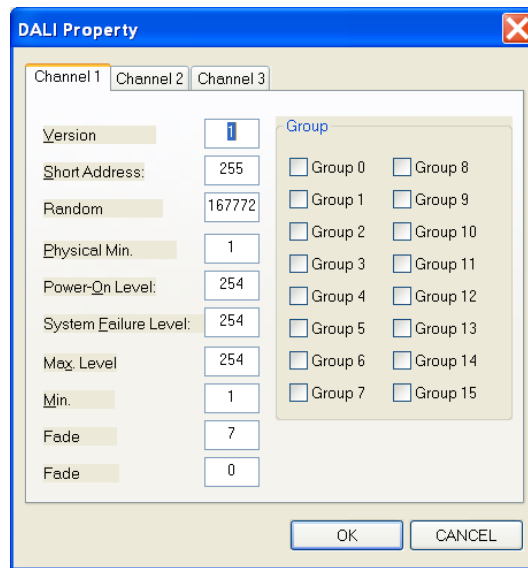

Figure 36: Applilet EZ for HCD Controller DALI Property Dialogue Box

- <5> Make sure that SW2 dip switch of the *RL78/I1A DC/DC LED Control Evaluation Board* is in flash programming mode, and that the USB and power supply cables are connected correctly. Click the **“Save”** button and then the **“All P.”** button. After downloading the application, please disconnect the USB and power supply cables and set the board to the normal operation mode.

You should now be able to control the LEDs on the *RL78/I1A DC/DC LED Control Evaluation Board* via the DALI protocol by connecting a DALI master device. For example, Renesas Electronics offers the *Lighting Communication Master Evaluation Board (EZ-0008)*. This board can be used as a communication master device supporting DMX512, DALI and IR communications.

- <6> The *RL78/I1A DC/DC LED Control Evaluation Board* can be controlled by this *Lighting Communication Master Evaluation Board* together with a GUI running on the host PC. There is a GUI for DMX512 control and a GUI for DALI control, both GUIs can be downloaded from the Renesas Electronics website.

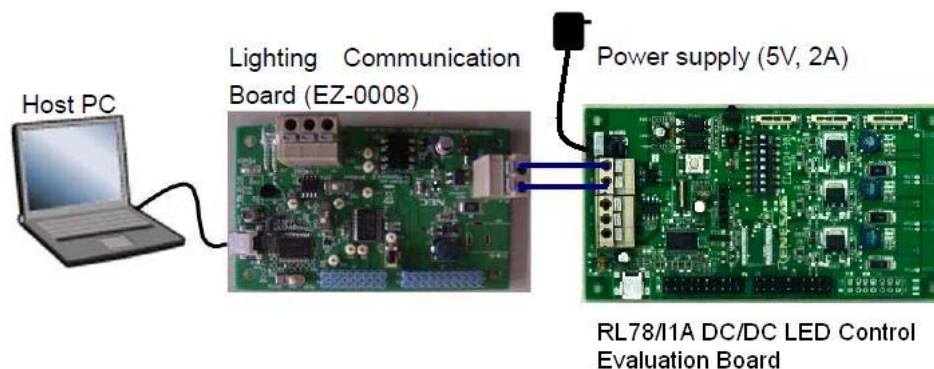

Figure 37: System Configuration for DALI Control

- <7> On the *Lighting Communication Master Evaluation Board*, please confirm that SW4 is set to "RUN".
- <8> Connect the *Lighting Communication Master Evaluation Board* (EZ-0008), via the DALI connector J4, with the *RL78/I1A DC/DC LED Control Evaluation Board* (acting as a DALI slave board), via the DALI connector CN2, using the two wires provided.
- <9> Connect the *Lighting Communication Master Evaluation Board* to the host PC using a USB cable.
- <10> Plug the DC 5V power supply cable to the *RL78/I1A DC/DC LED Control Evaluation Board* via connector CN1.
- <11> Send DALI commands to the *RL78/I1A DC/DC LED Control Evaluation Board* using the DALI Master Controller GUI.

Note To find details about the DALI Master Controller GUI, please refer to the corresponding User's Manual (U19607EJ1V1UM00) that can be downloaded from the Renesas Electronics website.

8.7 IR Remote Control Dimmer Program

This sample shows how to set up Applilet EZ to program the IR remote control dimming program into the R5F107DEG assembled to the *RL78/I1A DC/DC LED Control Evaluation Board*.

- <1> Make sure that you have set all the settings as explained in the *8.1 General Settings* section.
- <2> Save the new Applilet EZ project (.hcd file). Select the **File** menu, then click on **Save As...** or simply click on the "**Save**" button, and input "**ir.hcd**" for example. To finish click **Save**.
- <3> We now have a new Applilet EZ project file and we will change the dimmer program to IR Remote Control. The "Custom Code" and "Data Code" can be customized according to the user's needs.

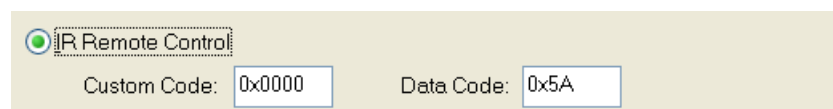

Figure 38: Applilet EZ for HCD Controller Dimmer Program Selection (IR)

- <4> Make sure that SW2 dip switch of the *RL78/I1A DC/DC LED Control Evaluation Board* is in flash programming mode, and that the USB and power supply cables are connected correctly. Click the “**Save**” button and then the “**All P.**” button. After downloading the application, please disconnect the USB and power supply cables and set the board to the normal operation mode.
- <5> Plug again the DC 5V power supply, and you should now be able to control the LEDs on the *RL78/I1A DC/DC LED Control Evaluation Board* via the IR remote control protocol by using an IR transmitter device. For example, Renesas Electronics offers the *Lighting Communication Master Evaluation Board* (EZ-0008). This board can be used as a communication master device supporting DMX512, DALI and IR communications.

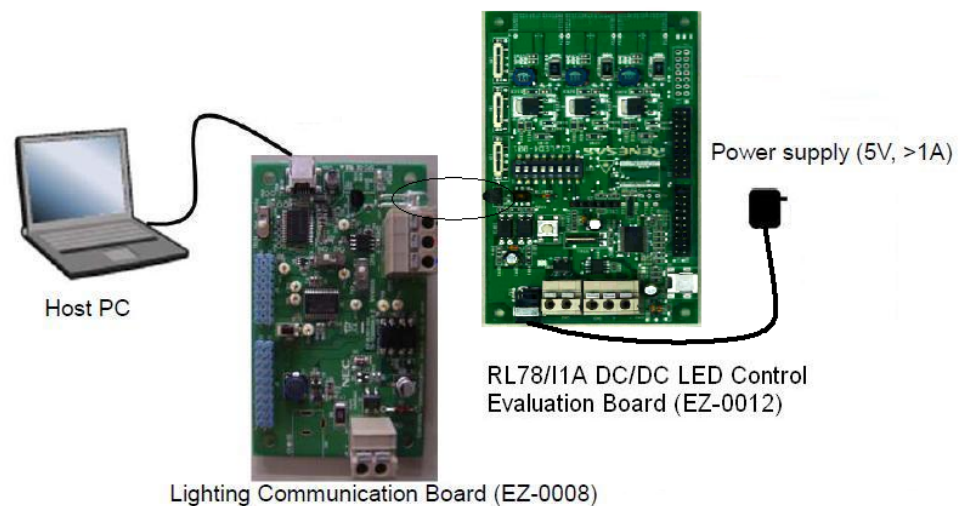

Figure 39: System Configuration for IR Remote Control

- <6> On the *Lighting Communication Master Evaluation Board*, please confirm that SW4 is set to “RUN” and SW1 to the expected channel (the channel should be the same as the one set in Applilet EZ for HCD).
- The output code is based on NEC IR remote control protocol:
- CH1: Send custom code 0x0000+data code 0x5AA5
- CH2: Send custom code 0x0000+data code 0xDA25
- <7> Place the IR transmitter (LED1) of the *Lighting Communication Master Evaluation Board* in the line-of-sight of the IR receiver (U2) of the *RL78/I1A DC/DC LED Control Evaluation Board*.
- <8> Connect the *Lighting Communication Master Evaluation Board* to the host PC using a USB cable.
- <9> Plug the DC 5V power supply cable to the *RL78/I1A DC/DC LED Control Evaluation Board* via connector CN1.
- <10> Press switch SW2 of the *Lighting Communication Master Evaluation Board* to send IR signals to the *RL78/I1A DC/DC LED Control Evaluation Board*.

Chapter 9 Troubleshooting

- **In driver installation, recognition based on Plug and Play is disabled.**

Cause:

The USB connector may not be inserted normally into the USB port of the personal computer.

Action:

Check that the USB connector is inserted fully into the USB port of the personal computer.

Alternatively, disconnect the USB connector, and then insert the USB connector again after a while.

- **The driver file cannot be found at a specific location**

Cause:

The WriteEZ5 programming software may not be installed correctly.

Action:

Install the WriteEZ5 software again by referring to **Chapter 6 Software Installation**.

- **In checking by Device Manager, "USB Serial Port" or "USB High Speed Serial Converter" is not displayed. Alternatively, the "!" or "x" is prefixed**

Cause:

The USB connector may not be inserted normally into the USB port of the personal computer.

Action:

Check that the USB connector is inserted fully into the USB port of the personal computer.

Alternatively, disconnect the USB connector from the USB port, then insert the USB connector again after a while.

Cause:

The driver may not be installed correctly.

Action:

<1> When this product is connected to the personal computer, right-click the driver marked with "!" or "x".

Click when displayed.

<2> On Device Manager, execute [Hardware Modification Scan].

<3> Install the driver again with Plug and Play.

Cause:

The device may not be recognized (in the case of connection with the USB hub).

Action:

Try the following:

- Disconnect the USB connector, then insert the USB connector again.
- Connect the USB connector to another port of the USB hub.

If the same symptom occurs, do not use the USB hub, but directly connect the connector to the USB port of the personal computer.

- **When this product is connected with a personal computer, the "Add New Hardware Wizard" screen is displayed**

Cause:

If the USB connector of this product is not inserted into the USB port used at the installation time but into another USB port, this product may be recognized as a new hardware item.

Action:

Install the driver by referring to **Chapter 6 Software Installation**.

- **Communication with the RL78/I1A DC/DC LED Control Evaluation Board is disabled**

Cause:

The driver may not be installed correctly.

Action:

Check if the USB driver is installed correctly by referring to **Chapter 6 Software Installation**.

Cause:

The COM port selected via the "Port list box" within device setup menu of WriteEZ5 may not be set correctly.

Action:

Set the port checked using Device Manager.

Cause:

The RL78/I1A DC/DC LED Control Evaluation Board is operating in Virtual UART mode.

Action:

Set the board to the On-Board Debugging / Flash Programming mode.

Cause:

The PRM file selected in [Device Setup] may be incorrect.

Action:

Use the corresponding PRM file that matches the target device. For information about the PRM file, refer to **Chapter 7 How to Use WriteEZ5 Flash Programming Software**.

Chapter 10 Schematics

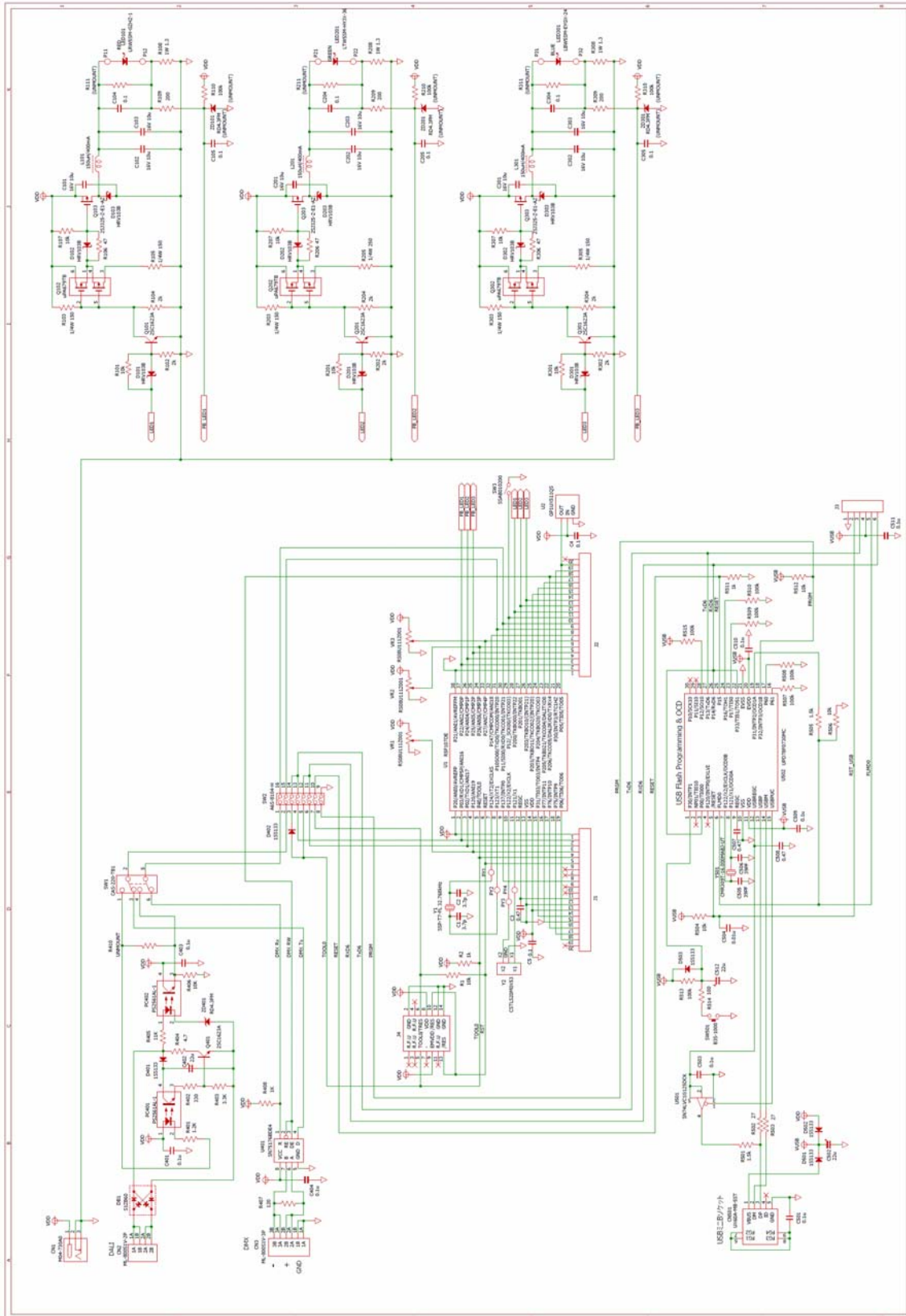

Figure 40: RL78/I1A DC/DC LED Control Evaluation Board Schematic

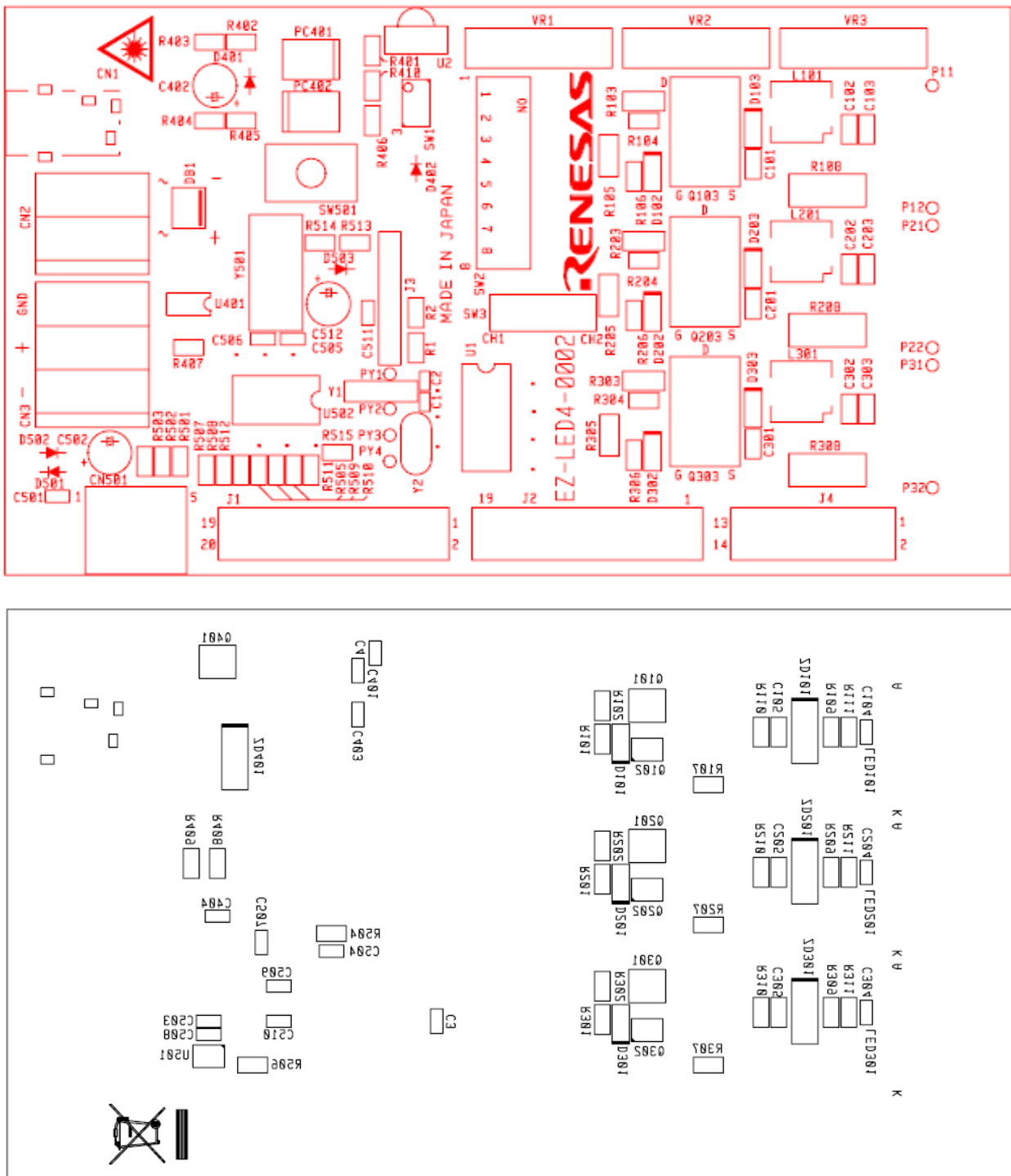

Figure 41: Top and Bottom Silkscreen

Chapter 11 Bill of Materials

Item	Reference	Parts name	Rating	Type
1	C1, C2	Laminated ceramic capacitor	3.7 pF @ 50 V	1005
2	C3	Laminated ceramic capacitor	0.47 μ F @ 25 V	1608
3	C4, C5	Laminated ceramic capacitor	0.1 μ F @ 50 V	1608
4	C101-C103, C201-C203, C301-C303	Laminated ceramic capacitor	10 μ F @ 16 V	2012
5	C104, C105, C204, C205, C304, C305, C401, C403, C404, C501, C503, C509-C511	Laminated ceramic capacitor	0.1 μ F @ 50 V	1608
6	C402, C502, C512	Electrolytic capacitor	22 μ F @ 50 V	DIP
7	C504	Laminated ceramic capacitor	0.01 μ F @ 50 V	1608
8	C505, C506	Laminated ceramic capacitor	39 pF @ 50 V	1608
9	C507, C508	Laminated ceramic capacitor	0.47 μ F @ 25 V	1608
10	CN1	Power Supply Jacks	EIAJ 2	DIP
11	CN2	Connector	2 poles	DIP
12	CN3	Connector	3 poles	DIP
13	CN501	USB connector	Micro-USB (USB2.0)	SMD
14				
15	D101-D303, D201-D203, D301-D303	Schottky-barrier diode	30 V, 1 A	SMD
16	D401, D402, D501-D503	diode	80 V, 0.4 A	DIP
17	DB	Bridge diode	600 V, 0.5 A	SMD
18	J1, J2	DIP pin header	20 p	DIP
19	J3	SIP pin header	6 p	DIP
20	L1-L3	Inductance	150 μ H, 400 mA	SMD
21	LED101	High power LED	Red	SMD
22	LED201	High power LED	Green	SMD
23	LED301	High power LED	Blue	SMD
24	PC401, PC402	Photocoupler		SMD
25	Q101, Q201, Q301, Q401	Transistor	60 V, 0.1 A	SC-59
26	Q102, Q202, Q302	Transistor array	20 V, 0.25 A	SMD
27	Q103, Q203, Q303	Power MOSFET	30 V, 4 A	TO-252
28	R1, R101, R107, R201, R207, R301, R307, R406, R504, R506, R512, R513	SMT resistor	10 k Ω , 0.125 W	2012
29	R2, R408, R511	SMT resistor	1 k Ω , 0.125 W	2012
30	R102, R104, R202, R204, R302, R304	SMT resistor	2 k Ω , 0.125 W	2012
31	R103, R105, R203, R205, R303, R305	SMT resistor	150 Ω , 0.25 W	3216
32	R106, R206, R306	SMT resistor	47 Ω , 0.125 W	2012
33	R108, R208, R308	SMT resistor	1.3 Ω , 0.5 W	6331
34	R109, R209, R309	SMT resistor	200 Ω , 0.125 W	2012
35	R401	SMT resistor	1.2 k Ω , 0.125 W	2012
36	R402	SMT resistor	330 Ω , 0.125 W	2012
37	R403	SMT resistor	3.3 k Ω , 0.125 W	2012
38	R404	SMT resistor	4.7 Ω , 0.125 W	2012
39	R405	SMT resistor	11 k Ω , 0.125 W	2012
40	R407	SMT resistor	120 Ω , 0.125 W	2012

Item	Reference	Parts name	Rating	Type
41	R501, R505	SMT resistor	1.5 k Ω , 0.125 W	2012
42	R502, R503	SMT resistor	27 Ω , 0.125 W	2012
43	R507-R510, R515	SMT resistor	100 k Ω , 0.125 W	2012
44	R514	SMT resistor	100 Ω , 0.125 W	2012
45				
46	SW1	Slide switch	Black	SMD
47	SW2	DIP switch	8 poles	SMD
48	SW3	Slide switch	1 pole	DIP
49	SW501	Push switch	1 pole	SMD
50	U1	CPU	38 pins	SMD
51	U2	RECEIVER IR REM CTRL		DIP
52	U401	Interface IC		SMD
53	U501	Interface IC		SMD
54	U502	CPU	30 pins	SMD
55	VR1-VR3	Slide volume	10 k Ω	SMD
56	Y1	Ceramic resonator	32.196 kHz	SMD
57	Y501	Crystal units	16 MHz	SMD
58	ZD401	Zener diode		SMD

Table 13: Bill of Materials

REVISION HISTORY	RL78/I1A DC/DC LED Control Demonstration Kit User's Manual: Hardware
------------------	---

Rev.	Date	Description	
		Page	Summary
1.00	Mar. 23, 2012	—	First edition issued

RL78/I1A DC/DC LED Control Demonstration Kit
User's Manual: Hardware

Publication Date: Rev. 1.00 Mar. 23, 2012

Published by: Renesas Electronics Corporation

RL78/I1A DC/DC LED Control Demonstration Kit