

DO NOT SCALE FROM THIS PRINT

NOTES:

- ⊗ REPRESENTS A CRITICAL DIMENSION.
- MAXIMUM POST HEIGHT VARIATION: .005[0.13].
- LOAD PARTS POS 1 IN SAME DIRECTION AS ARROW.
- TUBE POSITIONS 03 THRU 50.
- TAPE & REEL AVAILABLE ON POSITION 02 THRU 28 ONLY. LEADS MAY NOT BE VISIBLE FOR CUSTOMER'S VISUAL INSPECTION ON SMALLER POSITIONED PARTS WHEN USED WITH THE -P OR -M OPTIONS.
- MEASURE AT BEND RADIUS.
- MINIMUM PUSHOUT FORCE: 3 LBS.
- FOR -TV USE T-31724-01.
- DUE TO THE HIGH AMOUNT OF INSERTION FORCE NEEDED, THE -LC OPTION IS NOT COMPATIBLE WITH AUTO PLACEMENT. SAMTEC RECOMMENDS MANUAL PLACEMENT FOR ALL ASSEMBLIES WITH THE -LC OPTION.
- ONLY AVAILABLE ON -01-DV OPTION, MATES ONLY WITH SSM, SSW, SSQ, BCS, ESW AND ESQ.
- MAXIMUM CUT FLASH: .005[0.13]
- THIS DIMENSION TO BE MEASURED RELATIVE TO DATUM -Z-.

MOUNT STYLE	POSITIONS	COPLANARITY
-DV	-02 THRU -05	.004 [0.10]
	-06 THRU -10	.005 [0.13]
	-11 THRU -50	.006 [0.15]
-TV & -TM	-02 THRU -10	.004 [0.10]
	-11 THRU -20	.005 [0.13]
	-21 THRU -30	.006 [0.15]

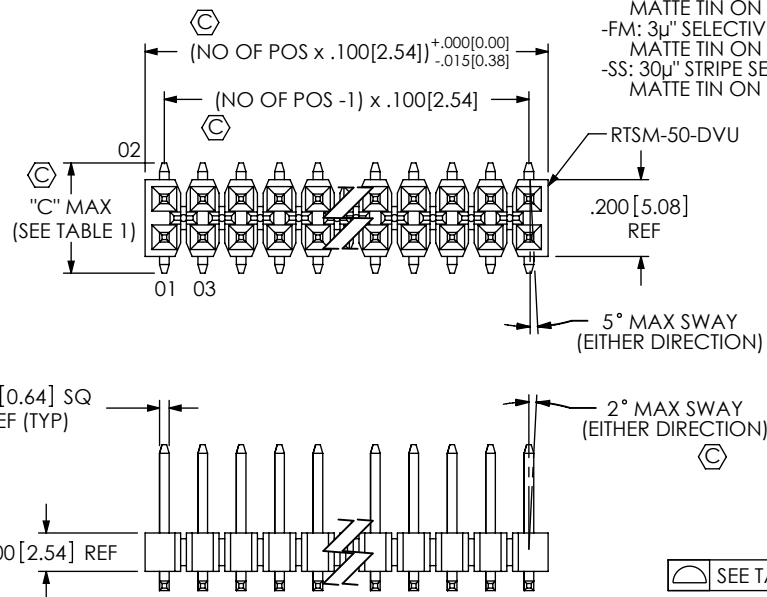

FIG 1
TSM-1XX-XX-XXX-DV SHOWN

LEAD STYL	MOUNT STYLE	"B"	"C"	"D"	TERMINAL	OVERALL PIN LENGTH
-01	-DV	0.230 [5.84]	0.303 [7.70]	0.280 [7.11]	T-1S6-16-X-2	0.445 [11.30] REF
	-TM, -TV	0.230 [5.84]	---	---	T-1S6-17-X-2	0.480 [12.19] REF
-02	-DV	0.320 [8.13]	0.293 [7.44]	0.370 [9.40]	T-1S6-08-X-2	0.530 [13.46] REF
-03	-DV	0.420 [10.67]	0.293 [7.44]	0.470 [11.94]	T-1S6-15-X-2	0.630 [16.00] REF
-04	-DV	0.120 [3.05]	0.303 [7.70]	0.270 [6.86]	T-1S6-21-X-2	0.335 [8.51] REF
-05	-DV	0.075 [1.91]	0.323 [8.20]	0.270 [6.86]	T-1S6-18-X-2	0.300 [7.62] REF

TSM-1XX-XX-XXX-XX-X-XXX-X

NO OF POSITIONS
-02 THRU -50

LEAD STYLE
(SEE TABLE 1)

PLATING SPECIFICATION

- T: MATTE TIN ON ENTIRE PIN.
- S: 30μ" SELECTIVE GOLD IN CONTACT AREA, MATTE TIN ON TAIL.
- G: 10μ" SELECTIVE GOLD IN CONTACT AREA, 3μ" SELECTIVE GOLD ON TAIL.
- L: 10μ" SELECTIVE GOLD IN CONTACT AREA, MATTE TIN ON TAIL.
- TL: TIN/LEAD (90/10) ON ENTIRE PIN.
- STL: 30μ" SELECTIVE GOLD IN CONTACT AREA, TIN/LEAD (90/10) ON TAIL.
- F: 3μ" SELECTIVE GOLD IN CONTACT AREA, MATTE TIN ON TAIL.
- H: 30μ" SELECTIVE GOLD IN CONTACT AREA, 3μ" SELECTIVE GOLD ON TAIL.
- TM: MATTE TIN ON ENTIRE PIN.
- SM: 30μ" SELECTIVE GOLD IN CONTACT AREA, MATTE TIN ON TAIL.
- LM: 10μ" SELECTIVE GOLD IN CONTACT AREA, MATTE TIN ON TAIL.
- FM: 3μ" SELECTIVE GOLD IN CONTACT AREA, MATTE TIN ON TAIL.
- SS: 30μ" STRIPE SELECTIVE GOLD IN CONTACT AREA, MATTE TIN ON TAIL. (SEE NOTE 10)

OPTION #3

- (NOT AVAILABLE WITH -TV & -TM MOUNT STYLES)
- P: PICK AND PLACE PAD (USE PPP-06, SEE FIG 4, SHT 2) (AVAILABLE ON POS -04 THRU -36, -50) (AVAILABLE ON POS -02 & -03 WITH -TR OPTION ONLY, SEE NOTE 5)
- *-M: METAL PICK AND PLACE PAD (USE LMP-01, SEE FIG 5, SHT 2) (NOT RECOMMENDED WITH -T OR -TM PLATING) (LEAD STYLES -01 & -04 ONLY) (AVAILABLE ON POS 04 THRU 36) (AVAILABLE ON POS 02 AND 03 WITH -TR OPTION ONLY, SEE NOTE 5)
- TR: TAPE AND REEL (SEE FIG 8, SHT 3) (02 THRU 28 POS)

OPTION #2

POLARIZED POSITION
SPECIFY OMITTED PIN

OPTION #1

- (AVAILABLE FOR -DV MOUNT STYLE ONLY)
- LC: LOCKING CLIP (SEE FIG 2, SHT 2) (USE LC-05-TM) (-03 THRU -36 POS, USE 2 PER STRIP) (-02 POS, USE 1 PER STRIP) (USE RTSM-XX-DVU) (SEE NOTE 9)
- A: ALIGNMENT PIN (SEE FIG 3, SHT 2) (FOR MOLDED TO POSITION, USE RTSM-XX-DVU-XX BODY) (FOR STAKED, USE RTSM-50-DVU BODY, 5 POS MIN) (LEAVE BLANK FOR NO HOLD DOWN OPTION) USE RTSM-50-DVU SEE FIG 1, CAN BE CUT TO POSITION)

MOUNT STYLE

- DV: DOUBLE VERTICAL
- *-TV: TRIPLE VERTICAL (-02 THRU -30 ONLY) (USE HTSW-50-T-LCP, SEE NOTE 8)
- TM: TRIPLE MIXED TECHNOLOGY (-02 THRU -30 ONLY) (USE HTSW-50-T-LCP, AVAILABLE ON -01 LEAD STYLE ONLY)

* = FOR EXISTING CUSTOMERS ONLY

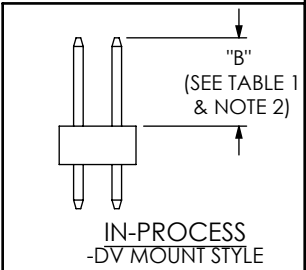
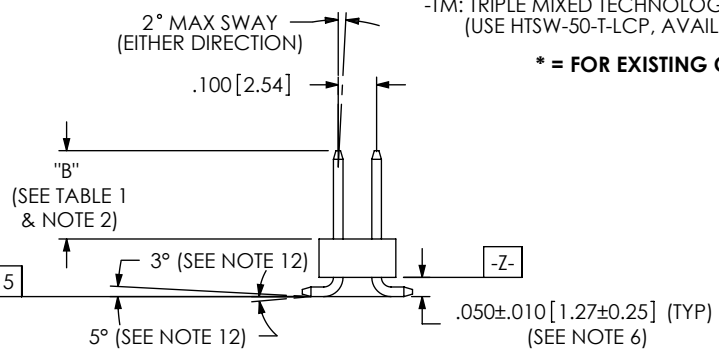

SEE TABLE 5

UNLESS OTHERWISE SPECIFIED, DIMENSIONS ARE IN INCHES. TOLERANCES ARE:
DECIMALS ANGLES
.XX: ±.01 [.3] 2°
.XXX: ±.005 [.13]
.XXXX: ±.0020 [.051]

PROPRIETARY NOTE
THIS DOCUMENT CONTAINS INFORMATION CONFIDENTIAL AND PROPRIETARY TO SAMTEC, INC. AND SHALL NOT BE REPRODUCED OR TRANSFERRED TO OTHER DOCUMENTS OR DISCLOSED TO OTHERS OR USED FOR ANY PURPOSE OTHER THAN THAT WHICH IT WAS OBTAINED WITHOUT THE EXPRESSED WRITTEN CONSENT OF SAMTEC, INC.

samtec
520 PARK EAST BLVD, NEW ALBANY, IN 47150
PHONE: 812-944-6733 FAX: 812-948-5047
e-Mail info@SAMTEC.com code 55322

DESCRIPTION: DOUBLE ROW GULLWING ASM

DWG. NO. TSM-1XX-XX-XXX-XX-X-XXX-X

BY: BRYANT 04/24/1991 SHEET 1 OF 3

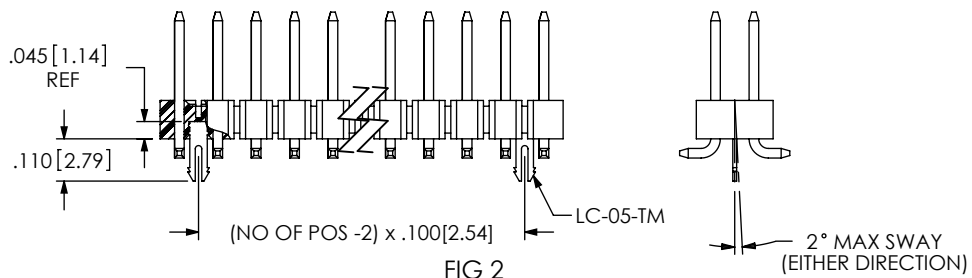

FIG 2
-LC: LOCKING CLIP
(DIFFERENT AS SHOWN, OTHERWISE SAME AS FIG 1)

TABLE 3			
	"A"	BODY	MIN NO OF POS
MOLDED	.100[2.54] REF	RTSM-50-DVU-X	2
*STAKED	.100[2.54]	RTSM-50-DVU-X	5

* = USE TWO SM-AH'S

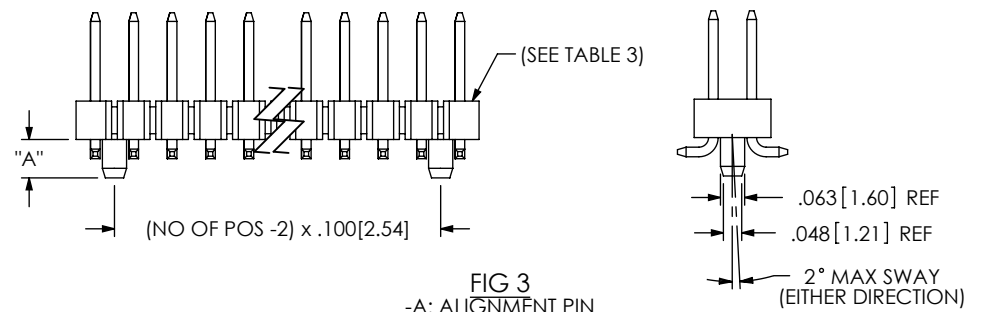

FIG 3
-A: ALIGNMENT PIN
(DIFFERENT AS SHOWN, OTHERWISE SAME AS FIG 1)

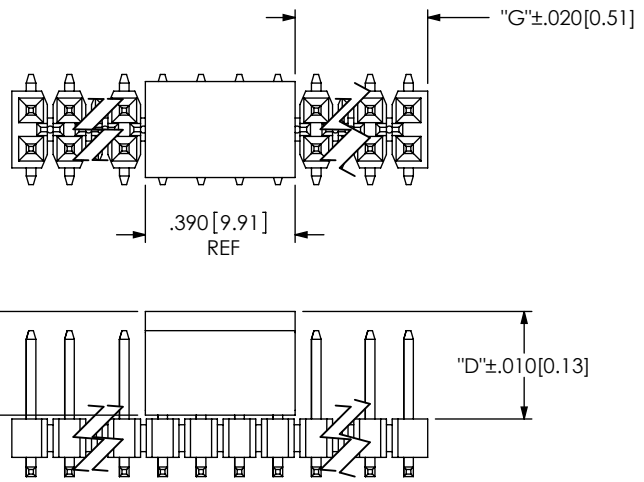

FIG 4
-P: PICK AND PLACE PAD
(DIFFERENT AS SHOWN, OTHERWISE SAME AS FIG 1)

"G" = ((NO OF POS x .100[2.54]) - .390[9.91])/2

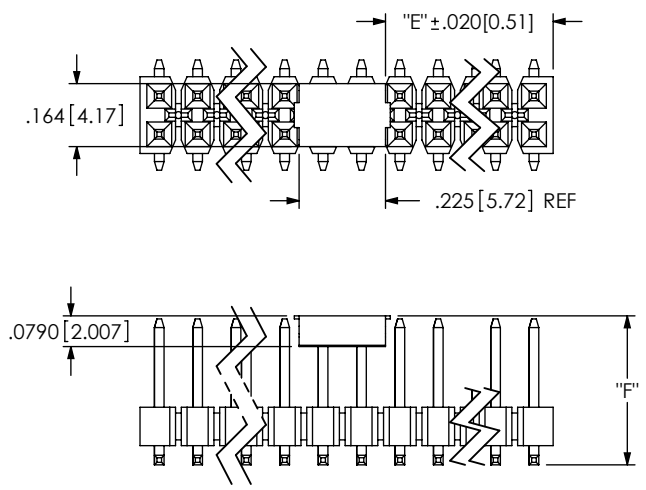

FIG 5
-M: METAL PICK AND PLACE PAD
(DIFFERENT AS SHOWN, OTHERWISE SAME AS FIG 1)
"E" = ((NO OF POS x .100[2.54]) - .225[5.72]) / 2

NOTE:
HAND FILL USE LMP-01
MACHINE FILL USE LMP-01

TABLE 2	
LEAD STYLE	"F"
-01	0.388[9.86]
-04	0.278[7.06]

PROPRIETARY NOTE
THIS DOCUMENT CONTAINS INFORMATION CONFIDENTIAL AND PROPRIETARY TO SAMTEC, INC. AND SHALL NOT BE REPRODUCED OR TRANSFERRED TO OTHER DOCUMENTS OR DISCLOSED TO OTHERS OR USED FOR ANY PURPOSE OTHER THAN THAT WHICH IT WAS OBTAINED WITHOUT THE EXPRESSED WRITTEN CONSENT OF SAMTEC, INC.

DO NOT SCALE DRAWING
SHEET SCALE: 2:1



520 PARK EAST BLVD, NEW ALBANY, IN 47150
PHONE: 812-944-6733 FAX: 812-948-5047
e-Mail info@SAMTEC.com code 55322

DESCRIPTION: **DOUBLE ROW GULLWING ASM**
DWG. NO. **TSM-1XX-XX-XXX-XX-X-XXX-X**
BY: BRYANT 04/24/1991 SHEET 2 OF 3

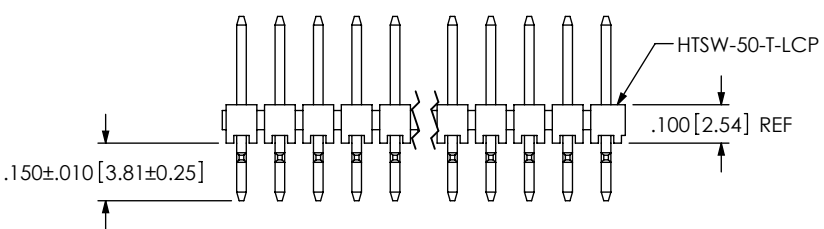

FIG 6
-TM: TRIPLE MIXED TECHNOLOGY
(DIFFERENT AS SHOWN, OTHERWISE SAME AS FIG 1)

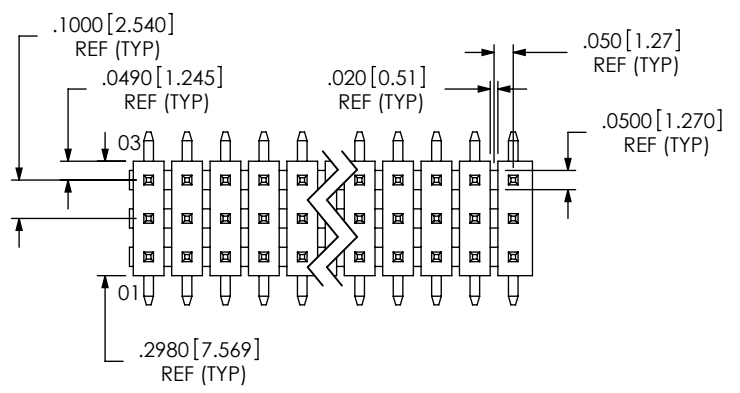
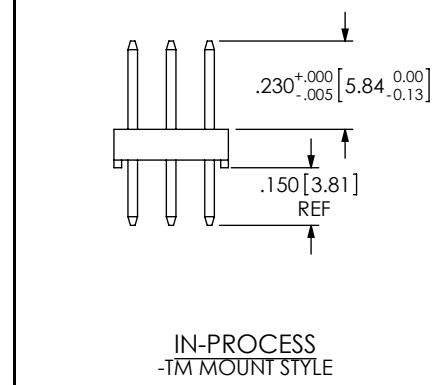
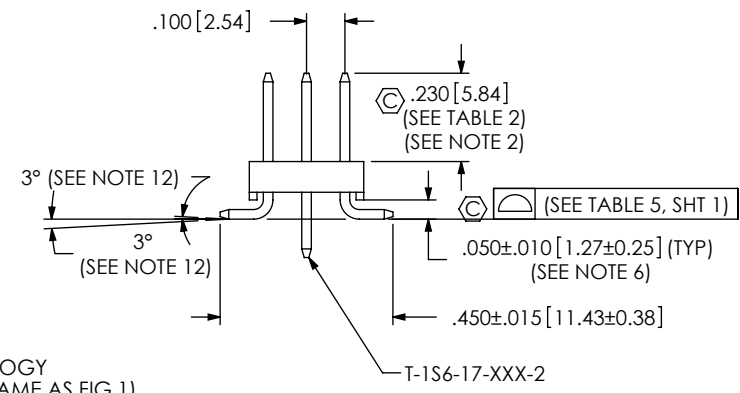

FIG 7
-TV: TRIPLE VERTICAL
(DIFFERENT AS SHOWN, OTHERWISE SAME AS FIG 6)
FOR EXISTING CUSTOMERS ONLY

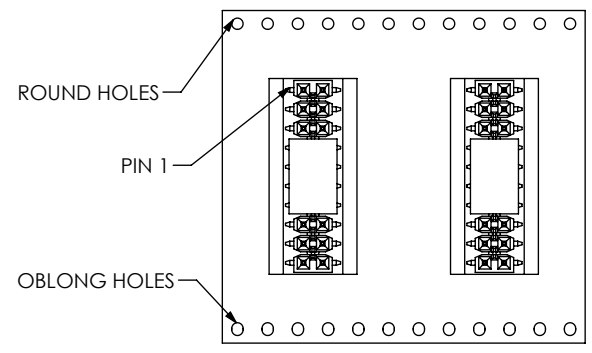
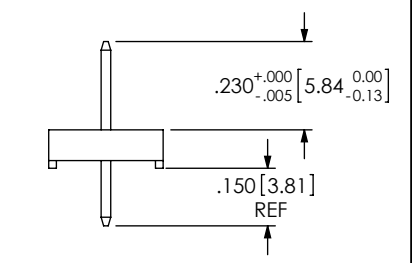
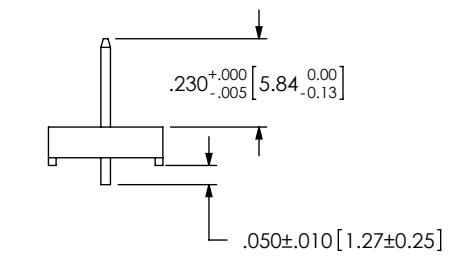

FIG 8
PACKAGING VIEWS

TABLE 4					
LEAD STYLE	MOUNT STYLE	OPTION	TUBE	PLUG	NOTE
01, 02, 04, 05	-DV	NONE	PT-1-24-01-29	TP-03	4
01, 02	-DV	-LC, -A	PT-1-24-01-29	TP-03	4
01, 04, 05	-DV	-P	PT-1-24-06-29	TP-03	4
01, 04, 05	-DV	-LC-P, -A-P	PT-1-24-06-29	TP-03	4
02	-DV	-P	PT-1-24-15-29	TP-07	4
02	-DV	-LC-P, -A-P	PT-1-24-15-29	TP-07	4
03	-DV	NONE	PT-1-24-09-29	TP-03	4
03	-DV	-LC, -A	PT-1-24-09-29	TP-03	4
03	-DV	-P	PT-1-24-16-29	TP-03	4
03	-DV	-LC-P, -A-P	PT-1-24-16-29	TP-03	4
04, 05	-DV	-LC, -A	PT-1-24-03-15	TP-03	4
01, 04, 05	-DV	-M, -LC-M, -A-M, -LC-A-M	PT-TSM004-DV	TP-03	4
01	-TM	NONE	PT-1-24-02-08	TP-13	4
01	-TV	NONE	PT-1-24-01-70	TP-07	4



IN-PROCESS 1
-TV MOUNT STYLE



IN-PROCESS 2
-TV MOUNT STYLE

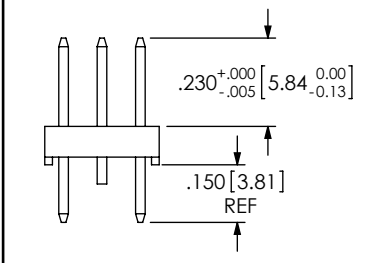

IN-PROCESS 3
-TV MOUNT STYLE

PROPRIETARY NOTE
THIS DOCUMENT CONTAINS INFORMATION CONFIDENTIAL AND PROPRIETARY TO SAMTEC, INC. AND SHALL NOT BE REPRODUCED OR TRANSFERRED TO OTHER DOCUMENTS OR DISCLOSED TO OTHERS OR USED FOR ANY PURPOSE OTHER THAN THAT WHICH IT WAS OBTAINED WITHOUT THE EXPRESSED WRITTEN CONSENT OF SAMTEC, INC.

DO NOT SCALE DRAWING
SHEET SCALE: 2:1



DESCRIPTION: **DOUBLE ROW GULLWING ASM**
DWG. NO. **TSM-1XX-XX-XXX-XX-X-XXX-X**
BY: BRYANT 04/24/1991 SHEET 3 OF 3