



STRATUM 3E High Stability Oven Stabilized Oscillator OH300 Series

OCXO / VCOCXO

CONNOR WINFIELD



2111 Comprehensive Drive

Aurora, Illinois 60505

Phone: 630-851-4722

Fax: 630-851-5040

www.conwin.com

US Headquarters:

630-851-4722

European Headquarters:

+353-61-472221

Description

Connor-Winfield's high stability OH300 series are exceptionally precise frequency standard, excellent for use in cellular base stations, test equipment, Synchronous Ethernet, VSAT and STRATUM 3E applications

These unique OCXO / VCOCXO Oscillators provide frequency stabilities in the range of ± 5 ppb to ± 50 ppb, over the commercial, extended commercial or the industrial temperature range. Power requirements are 1.1W over the commercial temperature range and 1.5W over the industrial temperature range after warm-up. Additionally, excellent aging is achieved through the use of overtone SC cut crystals.

The OH300 series is available with CMOS logic or Sinewave output along with Voltage Controlled option. These oscillators provide outstanding phase noise that varies depending on frequency requirements. Allan Variance specifications are rated for primary reference standards. Warm up times are on the order of 5 minutes to 0.10 ppm of final frequency.

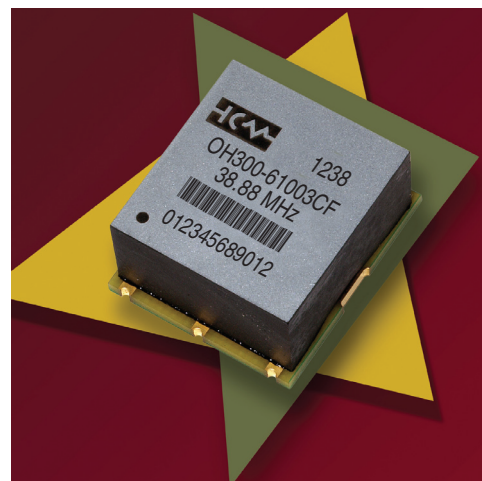

Features

- Frequency Range: 5 to 40 MHz
- OCXO - Fixed Frequency
- VCOCXO - Voltage Controlled Option
- 3.3 Vdc or 5.0 Vdc Operation
- Available Frequency Stabilities: ± 5.0 ppb, ± 10.0 ppb, ± 20 ppb or ± 50 ppb
- Available Temperature Ranges: 0 to 70°C, -20 to 70°C, -20 to 75°C, -40 to 70°C or -40 to 85°C
- Low Phase Noise / Phase Jitter
- Output: CMOS Logic or Sinewave
- SMT Package: 22 mm x 25 mm x 12.7 mm
- Tape and Reel Packaging
- RoHS Compliant / Lead Free ✓RoHS

Ordering Information

OH300-	6	10	03	C	F	- 038.88M
Package OH300- = 22x25mm Surface Mount Package	Temperature Range 5 = 0 to 70°C 6 = -40 to 85°C 7 = -20 to 70°C 8 = -40 to 70°C 9 = -20 to 75°C	Frequency Stability 05 = ± 5.0 ppb* 10 = ± 10.0 ppb 20 = ± 20.0 ppb 50 = ± 50.0 ppb	Supply Voltage 03 = 3.3 Vdc 05 = 5.0 Vdc	Output Type C = CMOS S = Sinewave	OCXO Type F = Fixed Freq. V = Voltage Controlled Option.	Output Frequency Frequency Format -xxx.xM Min -xxx.xxxxxM Max *Amount of numbers after the decimal point. M = MHz

* ± 5.0 ppb stability models are
only available from 0 to 70°C.

Example Part Number:

OH300-61003CF-038.88M = 22x25x12.7mm SMT package, -40 to 85°C temperature range, ± 10.0 ppb frequency stability, 3.3 Vdc supply voltage, CMOS square wave output, fixed output frequency OCXO, 38.88 MHz output frequency.

OH300-52005CV-010.0M = 22x25x12.7mm SMT package, 0 to 70°C temperature range, ± 20.0 ppb frequency stability, 5.0 Vdc supply voltage, CMOS square wave output, voltage controlled output frequency, VCOCXO, 10.0 MHz output frequency.

OH300-75005SV-020.0M = 22x25x12.7mm SMT package, -20 to 70°C temperature range, ± 50.0 ppb frequency stability, 5.0 Vdc supply voltage, Sinewave output, voltage controlled output frequency, VCOCXO, 20.0 MHz output frequency.



Attention: System Designers please review Application Note AN2093:
System Design Information and Printed Circuit Board Layout Guidelines for OCXO Oscillators.
@ www.conwin.com/support.html



Bulletin	Cx210
Page	1 of 6
Revision	14
Date	19 Nov 2013



Absolute Maximum Ratings

Parameter	Minimum	Nominal	Maximum	Units	Notes
Storage Temperature	-55	-	125	°C	
Supply Voltage	-0.5	-	7.0	Vdc	
Control Voltage (Vc)	-0.5	-	7.0	Vdc	
Operating Supply Voltage 3.3 Vdc (Vcc)	3.13	3.30	3.47	Vdc	
Operating Supply Voltage 5.0 Vdc (Vcc)	4.75	5.00	5.25	Vdc	

Absolute Ratings: Stresses beyond those listed under "absolute maximum ratings" may cause permanent damage to the device. These are stress ratings only. The functional operation of the device at those or any other conditions beyond those indicated under "recommended operating conditions" is not implied. Exposure to conditions outside the "recommended operating conditions" for any extended period of time may adversely impact device reliability and result in failures not covered by warranty.

Operating Specifications

Parameter	Minimum	Nominal	Maximum	Units	Notes
Center Frequency: (Fo)	5	-	40	MHz	
Operating Temperature Range:					
Temperature Code 5	0	-	70	°C	
Temperature Code 6	-40	-	85	°C	
Temperature Code 7	-20	-	70	°C	
Temperature Code 8	-40	-	70	°C	
Temperature Code 9	-20	-	75	°C	
Frequency Calibration:	-0.1	-	0.1	ppm	@ 25°C
Frequency Stability vs. Change in Temperature:					
Stability Code 05	-5.0	-	5.0	ppb	1, 2
Stability Code 10	-10.0	-	10.0	ppb	2
Stability Code 20	-20.0	-	20.0	ppb	2
Stability Code 50	-50.0	-	50.0	ppb	2
Frequency Stability vs. Load	-2.0	-	2.0	ppb	±5%
Frequency Stability vs. Voltage	-2.0	-	2.0	ppb	±5%
Aging: Daily:					
5 MHz to 20 MHz	-1.0	-	1.0	ppb/day	3
>20 MHz to 40 MHz	-2.0	-	2.0	ppb/day	3
Aging: First Year:					
5 MHz to 20 MHz	-50	-	50	ppb	
>20 MHz to 40 MHz	-100	-	100	ppb	
Lifetime Tolerance: (20 Years)					
5 MHz to 20 MHz	-300	-	300	ppb	4
>20 MHz to 40 MHz	-500	-	500	ppb	4
Supply Voltage: (Vcc)					
Voltage Code 03	3.13	3.30	3.47	Vdc	5
Voltage Code 05	4.75	5.00	5.25	Vd	5
Power Consumption: Turn-On					
0 to 70°C Models	-	-	3.00	W	6
-20 to 70°C Models	-	-	3.20	W	6
-20 to 75°C Models	-	-	3.30	W	6
-40 to 85°C Models	-	-	3.80	W	6
Power Consumption: Steady State @ 25°C					
0 to 70°C Models	-	-	1.10	W	6
-20 to 70°C Models	-	-	1.15	W	6
-20 to 75°C Models	-	-	1.20	W	6
-40 to 85°C Models	-	-	1.50	W	6
Phase Jitter: (BW: 10 Hz to Fo/2)	-	-	1.0	ps rms	
Short Term Allan Deviation (1s)	-	1.0E-11	-	rms	
Start-Up Time:	-	-	500	ms	
Warm Up Time @ 25°C:	-	-	5	minutes	7



*Attention: System Designers please review Application Note AN2093:
System Design Information and Printed Circuit Board Layout Guidelines for OCXO Oscillators.
@ www.conwin.com/support.html*

Bulletin **Cx210**
Page **2 of 6**
Revision **14**
Date **19 Nov 2013**



Phase Noise Characteristics

Typical Phase Noise for 10 MHz OXCO's with CMOS Output

Parameter	Minimum	Nominal	Maximum	Units	Notes
@1Hz offset	-	-	-85	dBc/Hz	
@ 10Hz offset	-	-	-115	dBc/Hz	
@ 100Hz offset	-	-	-140	dBc/Hz	
@ 1KHz offset	-	-	-145	dBc/Hz	
@ 10KHz offset	-	-	-150	dBc/Hz	
@ 100KHz offset	-	-	-150	dBc/Hz	

Input Characteristics - Voltage Controlled Option (OCXO Type Code V)

Parameter	Minimum	Nominal	Maximum	Units	Notes
Control Voltage Range: (Vc)					
3.3 Vdc Models	0.30	1.65	3.00	V	8
5.0 Vdc Models	0.50	2.50	4.50	V	8
Frequency Pullability:	±0.4	-	-	ppm	
Input Impedance	100K	-	-	Ohms	

CMOS Output Characteristics (Output Code C)

Parameter	Minimum	Nominal	Maximum	Units	Notes
Load	-	15	-	pF	
3.3 Vdc Models					
Output Voltage: High (Voh)	3.0	-	-	V	
Low (Vol)	-	-	0.4	V	
Output Current: High (Ioh)	-	-	-4	mA	
Low (Iol)	-	-	4	mA	
5.0 Vdc Models					
Output Voltage: High (Voh)	4.7	-	-	V	
Low (Vol)	-	-	0.4	V	
Output Current: High (Ioh)	-	-	-8	mA	
Low (Iol)	-	-	8	mA	
Duty Cycle at 50% of Vcc	45	50	55	%	
Rise / Fall Time: 10% to 90%	-	-	6	ns	
Spurious Output	-	-	-80	dBc	

Sinewave Output Characteristics (Output Code S)

Parameter	Minimum	Nominal	Maximum	Units	Notes
Load	-	50	-	Ohms	
Output Power	5.0	-	-	dBm:	
Harmonics	-	-	-30	dBc	
Spurious	-	-	-80	dBc	

Package Characteristics

OH300 Package Package consisting of a FR-4 substrate and Ryton-R-4 cover. Water Resistant package, non-hermetic seal. (Engineering Properties of Ryton R-4 Application Note AN2100)

Re-Stabilization Time

Off Time	Re stabilization Time
<1 Hour	<2 Hours *
<6 Hour	<12 Hours *
<24 Hour	<48 Hours *
1 to 16 Days	48 Hours + 1/4 Off Time *
>16 Days	<6 Days *

* For a given off time, the time required to meet daily aging, short term stability requirements.

Notes:

- ±5.0 ppb stability models are only available from 0 to 70°C.
- Referenced to the frequency measured @ 25°C. OCXO with EFT, the control voltage (Vc) = nominal voltage.
- At time of shipment after 48 hours of operation.
- Inclusive of calibration, operating temperature, supply voltage change, load change and 20 years aging.
- Supply voltage must reach Vcc levels monotonically within a ramp-up time of <12 ms.
- Measured with Vcc = Nominal, in calm air.
- Measured @ 25°C, within ±100 ppb, referenced one hour after turn-on.
- To ensure proper operation of VCOCXO, the control voltage input must be biased the nominal control voltage. Failure to bias the Vc input will cause an unstable output condition.



Attention: System Designers please review Application Note AN2093:
System Design Information and Printed Circuit Board Layout Guidelines for OCXO Oscillators.
@ www.conwin.com/support.html

Bulletin	Cx210
Page	3 of 6
Revision	14
Date	19 Nov 2013



Environmental Characteristics

Shock	500 G's 1ms, Halfsine, 3 shocks per direction, per MIL-STD 202G, Method 213B Test Condition D.
Sinusoidal Vibration	0.06" D.A. or 10G's Peak, 10 to 500 Hz, per MIL-STD-202G, Method 204D, Test Condition A.
Random Vibration	5.35 G's rms. 20 to 2000 Hz per MIL-STD-202G, Method 214, Test Condition 1A, 15 minutes each axis.
Moisture	10 cycles, 95% RH, Per MIL-STD-202G, Method 112.
Marking Permanency	Per MIL-STD-202G, Method 215J.
Solder Process Recommendations:	RoHS compliant, lead free. See solder profile on page 6.
In-line reflow:	Refer to recommended reflow pre-heat and reflow temperatures on page 6. Package material consist of Ryton R-4 high temperature cover with FR4 substrate. Component solder is Pb free high temperature eutectic alloy with a melting point of 221°C.]
In-line oven profile:	We recommend using KIC profiler or similar device placing one of the thermocouples on the device to insure that the internal package temperature does not exceed 221°C.
Removal of device:	If for any reason the device needs to be removed from the board, use a temperature controlled repair station with profile monitoring capabilities. Following a monitored profile will insure the device is properly pre-heated prior to reflow. Refer to IPC 610E for inspection guidelines.

Recommended Cleaning Process: (If required)

Device is non-hermetic, water resistance with four weep holes, one in each corner to allow moisture to be removed during the drying cycle. We recommend in-line warm water wash with air knife and drying capabilities. If cleaner does not have drying capability, then use hot air circulated oven. Boards should be placed in the oven vertically for good water runoff

Device must be dried properly prior to use!

Note: If saponifier is used make sure the device is rinsed properly to insure all residues are removed. PH of saponifier should not exceed 10.

Drying Temperature: Between 85 to 100°C.

Drying Time: Time will vary depending on the board size.

Caution: Do not submerge the device!

Package Outline

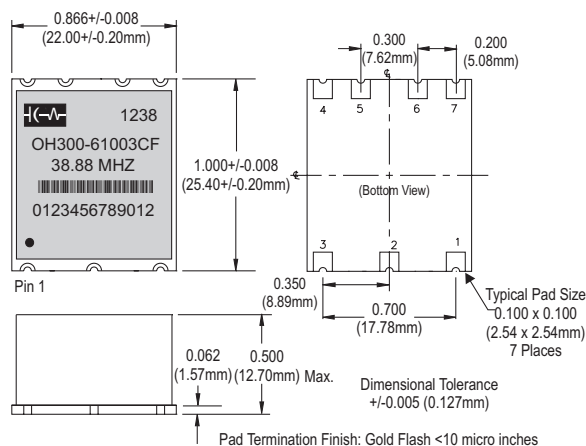

Suggested Pad Layout

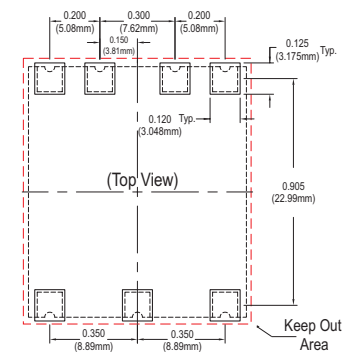

* Do not route any traces in the keep out area. It is recommended the next layer under the keep out area is to be ground plane.

Marking Information



Date Code (YYWW)

Model Number

Output Frequency

Serial # Barcode

Serial Number

Pad Connections

- 1: Voltage Control or N/C
- 2: N/C
- 3: Supply Voltage (Vcc)
- 4: RF Output
- 5: Do Not Connect
- 6: Do Not Connect
- 7: Ground (Case)

DO NOT connect "DNC" pads to ground or supply rails.

*Attention: System Designers please review Application Note AN2093:
System Design Information and Printed Circuit Board Layout Guidelines for OCXO Oscillators.
@ www.conwin.com/support.html*

Bulletin	Cx210
Page	4 of 6
Revision	14
Date	19 Nov 2013

Test Circuit CMOS Output

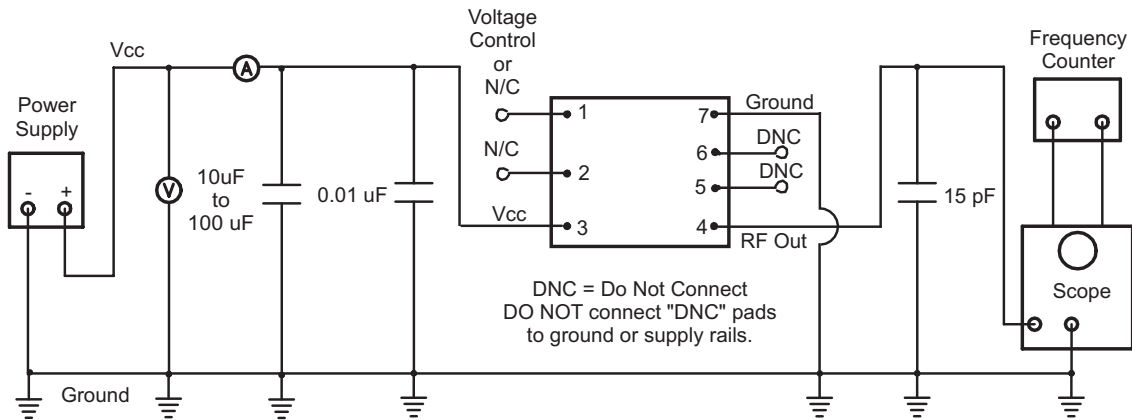

Test Circuit Sinewave Output

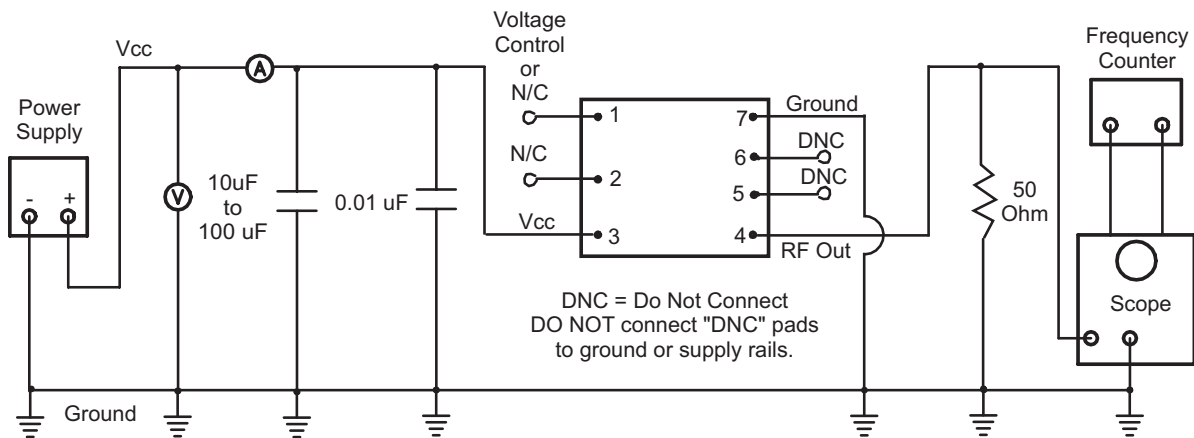

CMOS Output Waveform

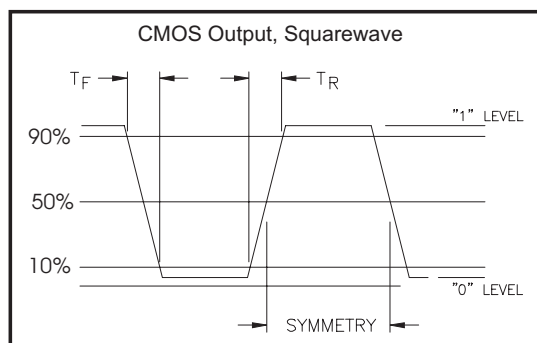

Sinewave Output Waveform

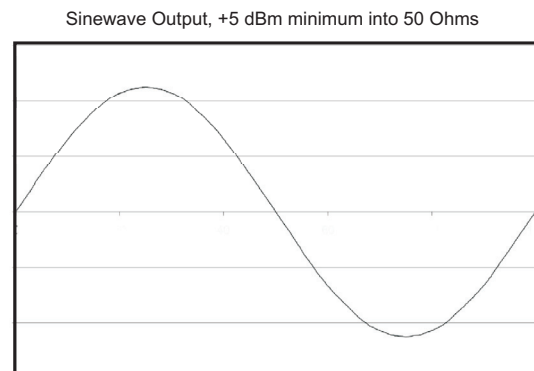

Attention: System Designers please review Application Note AN2093:
System Design Information and Printed Circuit Board Layout Guidelines for OCXO Oscillators.
@ www.conwin.com/support.html

Bulletin	Cx210
Page	5 of 6
Revision	14
Date	19 Nov 2013



Solder Profile

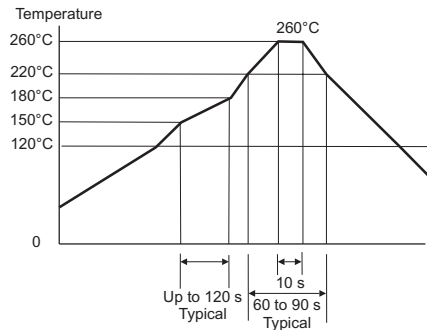

Meets IPC/JEDEC J-STD-020C

Tape and Reel Information

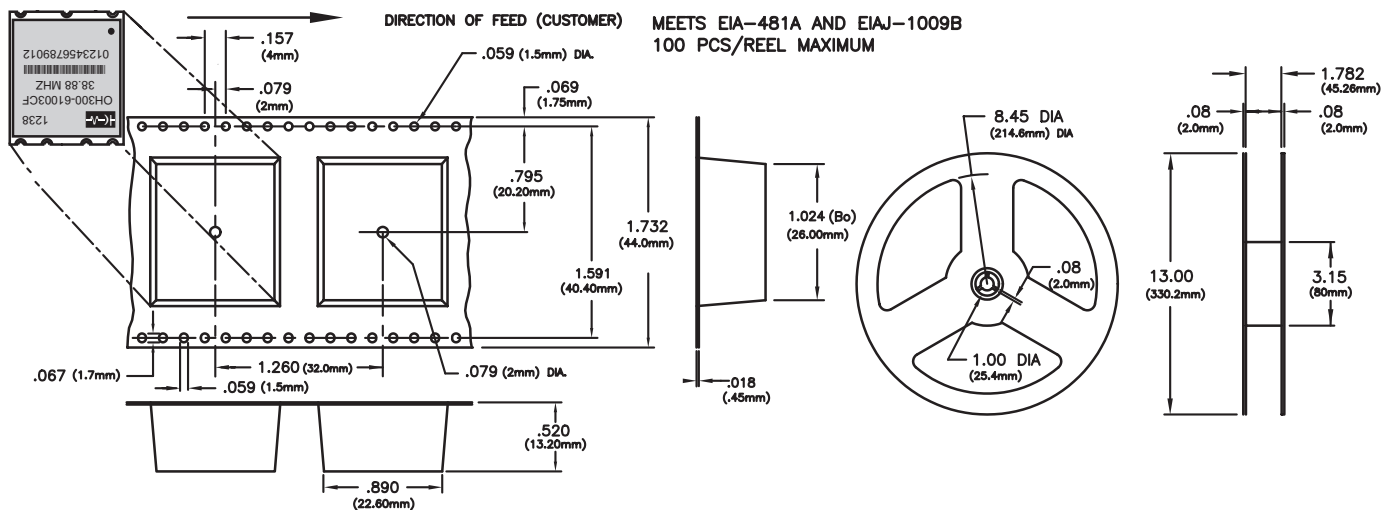

Revision History

Revision	Date	Changes
P00	01/26/11	New issue
P01	05/04/11	Added tape and reel information
P02	05/06/11	Added OH300 Photo
P03	05/25/11	updated Description
P04	07/27/11	Updated power consumption and changed package drawing
P05	09/08/11	Added sinewave models to the data sheet
P06	08/09/12	added cleaning process and package characteristics.
07	09/27/12	added Barcode to package marking
08	11/06/12	Added link to Application Note: AN2093
09	11/14/12	Added additional notes
10	12/07/12	Added additional notes
11	04/03/13	Added ±5ppb models
12	04/24/13	Updated Environmental Characteristics, added output drive current
13	05/13/13	Changed note 5 and removed note from power supply line, added absolute note
14	11/15/13	Added Voltage Control Option



**Attention: System Designers please review Application Note AN2093:
System Design Information and Printed Circuit Board Layout Guidelines for OCXO Oscillators.
@ www.conwin.com/support.html**

Bulletin	Cx210
Page	6 of 6
Revision	14
Date	19 Nov 2013