

Flexible Low Compression Series Fingerstock Gaskets

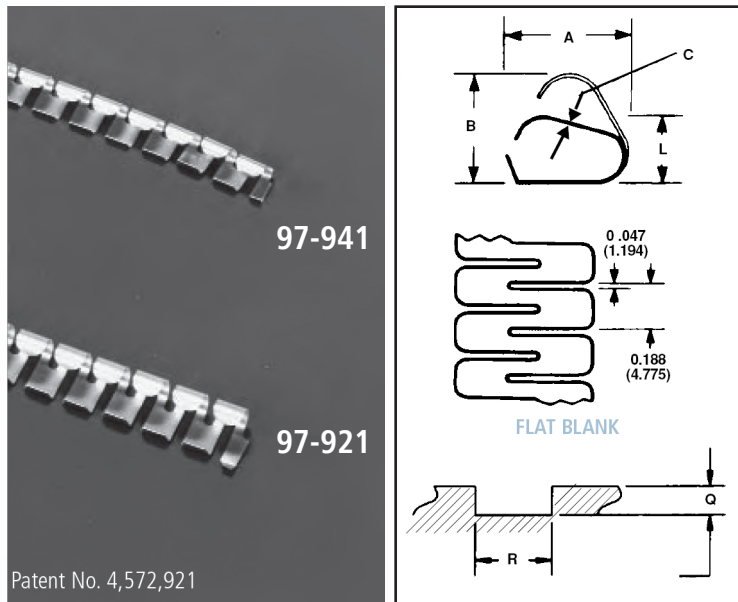

Patent No. 4,572,921

FINGERSTOCK GASKETS AND METAL GROUNDING PRODUCTS

As the world's leading fabricator of fingerstock, Laird Technologies has developed highly sophisticated, and often proprietary, shielding and grounding technology.

Our innovations are necessary to achieve outstanding combinations of performance parameters. From a vast selection of product configurations, platings and mounting techniques, to a full range of low compression force requirements and high transfer impedance characteristics, there is a Laird Technologies gasket or grounding product just right for the job.

Series 97-941/921 are low compression, flexible beryllium copper contact strips for applications where a continuous shield must conform to irregular shapes and turn tight radius corners in either direction.

Simple snap-in installation is possible for Series 97-921 with 0.250 in. (6.350 mm) slots and 97-941 with 0.190 in. (4.826 mm) slots. However, soft solder or conductive adhesive can be used for mounting to flat surfaces.

Shielding effectiveness is >115 dB for a 100 MHz plane wave.

Available in standard 24.000 in. (609.600 mm) lengths in all standard finishes.

| SERIES | A | B | C | L | Q | R | APPROX LENGTH IN (MM) |
|--------|------------------|------------------|------------------|------------------|------------------|------------------|-----------------------|
| 97-921 | 0.260 (6.604) | 0.230 (5.842) | 0.003 (0.076) | 0.140 (3.556) | 0.120 (3.048) | 0.250 (6.350) | 24.0 (609.600) |
| 97-941 | 0.200 (5.080) | 0.170 (4.318) | 0.003 (0.076) | 0.110 (2.794) | 0.090 (2.286) | 0.190 (4.826) | 24.0 (609.600) |

global solutions: local support™

USA: +1.866.928.8181

Europe: +49.0.8031.2460.0

Asia: +86.755.2714.1166

EMI-DS-FINGER-FLEX-LOW 1112

Any information furnished by Laird Technologies, Inc. and its agents is believed to be accurate and reliable. All specifications are subject to change without notice. Responsibility for the use and application of Laird Technologies materials rests with the end user. Laird Technologies makes no warranties as to the fitness, merchantability, suitability or non-infringement of any Laird Technologies materials or products for any specific or general uses. Laird Technologies shall not be liable for incidental or consequential damages of any kind. All Laird Technologies products are sold pursuant to the Laird Technologies Terms and Conditions of sale in effect from time to time, a copy of which will be furnished upon request. © Copyright 2012 Laird Technologies, Inc. All Rights Reserved. Laird, Laird Technologies, the Laird Technologies Logo, and other marks are trademarks or registered trademarks of Laird Technologies, Inc. or an affiliate company thereof. Other product or service names may be the property of third parties. Nothing herein provides a license under any Laird Technologies or any third party intellectual property rights.