

Quad channel high-side driver with MultiSense analog feedback for automotive applications

Datasheet - production data



- Configurable latch-off on overtemperature or power limitation with dedicated fault reset pin
- Loss of ground and loss of V_{CC}
- Reverse battery with external components
- Electrostatic discharge protection

Features

Max transient supply voltage	V_{CC}	40 V
Operating voltage range	V_{CC}	4 to 28 V
Typ. on-state resistance (per Ch)	R_{ON}	140 m Ω
Current limitation (typ)	I_{LIMH}	12 A
Stand-by current (max)	I_{STBY}	0.5 μ A

- General
 - Quad channel smart high-side driver with MultiSense analog feedback
 - Very low standby current
 - Compatible with 3 V and 5 V CMOS outputs
- MultiSense diagnostic functions
 - Multiplexed analog feedback of: load current with high precision proportional current mirror, V_{CC} supply voltage and T_{CHIP} device temperature
 - Overload and short to ground (power limitation) indication
 - Thermal shutdown indication
 - OFF-state open-load detection
 - Output short to V_{CC} detection
 - Sense enable/disable
- Protections
 - Undervoltage shutdown
 - Overvoltage clamp
 - Load current limitation
 - Self limiting of fast thermal transients

Applications

- All types of automotive resistive, inductive and capacitive loads
- Specially intended for automotive signal lamps (up to R10W or LED Real Combinations)

Description

The VNQ7140AJ-E is a quad channel high-side driver manufactured using ST proprietary VIPower[®] technology and housed in PowerSSO-16 package. The device is designed to drive 12 V automotive grounded loads through a 3 V and 5 V CMOS-compatible interface, providing protection and diagnostics.

The device integrates advanced protective functions such as load current limitation, overload active management by power limitation and overtemperature shutdown with configurable latch-off.

A $\overline{\text{FaultRST}}$ pin unlatches the output in case of fault or disables the latch-off functionality.

A dedicated multifunction multiplexed analog output pin delivers sophisticated diagnostic functions including high precision proportional load current sense, supply voltage feedback and chip temperature sense, in addition to the detection of overload and short circuit to ground, short to V_{CC} and OFF-state open-load.

A sense enable pin allows OFF-state diagnosis to be disabled during the module low-power mode as well as external sense resistor sharing among similar devices

Contents

1	Block diagram and pin description	6
2	Electrical specification	8
2.1	Absolute maximum ratings	8
2.2	Thermal data	9
2.3	Main electrical characteristics	10
2.4	Waveforms	23
2.5	Electrical characteristics curves	26
3	Protections	30
3.1	Power limitation	30
3.2	Thermal shutdown	30
3.3	Current limitation	30
3.4	Negative voltage clamp	30
4	Application information	31
4.1	GND protection network against reverse battery	31
4.1.1	Diode (DGND) in the ground line	32
4.2	Immunity against transient electrical disturbances	32
4.3	MCU I/Os protection	33
4.4	Multisense - analog current sense	33
4.4.1	Principle of Multisense signal generation	35
4.4.2	T _{CASE} and V _{CC} monitor	37
4.4.3	Short to VCC and OFF-state open-load detection	38
4.5	Maximum demagnetization energy (V _{CC} = 16 V)	39
5	Package and PCB thermal data	40
5.1	PowerSSO-16 thermal data	40
6	Package information	43
6.1	ECOPACK®	43
6.2	PowerSSO-16 package information	43

7	Order codes	45
8	Revision history	46

List of tables

Table 1.	Pin functions	6
Table 2.	Suggested connections for unused and not connected pins	7
Table 3.	Absolute maximum ratings	8
Table 4.	Thermal data	9
Table 5.	Power section	10
Table 6.	Switching ($V_{CC} = 13\text{ V}$; $-40^{\circ}\text{C} < T_j < 150^{\circ}\text{C}$, unless otherwise specified)	11
Table 7.	Logic Inputs ($7\text{ V} < V_{CC} < 28\text{ V}$; $-40^{\circ}\text{C} < T_j < 150^{\circ}\text{C}$)	11
Table 8.	Protections ($7\text{ V} < V_{CC} < 18\text{ V}$; $-40^{\circ}\text{C} < T_j < 150^{\circ}\text{C}$)	12
Table 9.	MultiSense ($7\text{ V} < V_{CC} < 18\text{ V}$; $-40^{\circ}\text{C} < T_j < 150^{\circ}\text{C}$)	13
Table 10.	Truth table	21
Table 11.	MultiSense multiplexer addressing	22
Table 12.	ISO 7637-2 - electrical transient conduction along supply line	32
Table 13.	MultiSense pin levels in off-state	37
Table 14.	PCB properties	40
Table 15.	Thermal parameters	42
Table 16.	PowerSSO-16 mechanical data	44
Table 17.	Device summary	45
Table 18.	Document revision history	46

List of figures

Figure 1.	Block diagram	6
Figure 2.	Configuration diagram (top view)	7
Figure 3.	Current and voltage conventions	8
Figure 4.	I_{OUT}/I_{SENSE} versus I_{OUT}	18
Figure 5.	Current sense precision vs. I_{OUT}	18
Figure 6.	Switching time and Pulse skew	19
Figure 7.	MultiSense timings (current sense mode)	19
Figure 8.	Multisense timings (chip temperature and VCC sense mode)	20
Figure 9.	T_{DSKON}	20
Figure 10.	Latch functionality - behavior in hard short circuit condition ($T_{AMB} \ll T_{TSD}$)	23
Figure 11.	Latch functionality - behavior in hard short circuit condition	23
Figure 12.	Latch functionality - behavior in hard short circuit condition (autorestart mode + latch off)	24
Figure 13.	Standby mode activation	24
Figure 14.	Standby state diagram	25
Figure 15.	OFF-state output current	26
Figure 16.	Standby current	26
Figure 17.	$I_{GND(ON)}$ vs. I_{out}	26
Figure 18.	Logic Input high level voltage	26
Figure 19.	Logic Input low level voltage	26
Figure 20.	High level logic input current	26
Figure 21.	Low level logic input current	27
Figure 22.	Logic Input hysteresis voltage	27
Figure 23.	FaultRST Input clamp voltage	27
Figure 24.	Undervoltage shutdown	27
Figure 25.	On-state resistance vs. T_{case}	27
Figure 26.	On-state resistance vs. V_{CC}	27
Figure 27.	Turn-on voltage slope	28
Figure 28.	Turn-off voltage slope	28
Figure 29.	W_{on} vs. T_{case}	28
Figure 30.	W_{off} vs. T_{case}	28
Figure 31.	I_{LIMH} vs. T_{case}	28
Figure 32.	OFF-state open-load voltage detection threshold	28
Figure 33.	V_{sense} clamp vs. T_{case}	29
Figure 34.	V_{senseh} vs. T_{case}	29
Figure 35.	Application diagram	31
Figure 36.	Simplified internal structure	31
Figure 37.	Multisense and diagnostic – block diagram	34
Figure 38.	Multisense block diagram	35
Figure 39.	Analogue HSD – open-load detection in off-state	36
Figure 40.	Open-load / short to VCC condition	37
Figure 41.	GND voltage shift	38
Figure 42.	Maximum turn off current versus inductance	39
Figure 43.	PowerSSO-16 on two-layers PCB (2s0p to JEDEC JESD 51-5)	40
Figure 44.	PowerSSO-16 on four-layers PCB (2s2p to JEDEC JESD 51-7)	40
Figure 45.	PowerSSO-16 $R_{thj-amb}$ vs PCB copper area in open box free air condition	41
Figure 46.	PowerSSO-16 thermal impedance junction ambient single pulse	41
Figure 47.	Thermal fitting model for PowerSSO-16	42
Figure 48.	PowerSSO-16 package dimensions	43

1 Block diagram and pin description

Figure 1. Block diagram

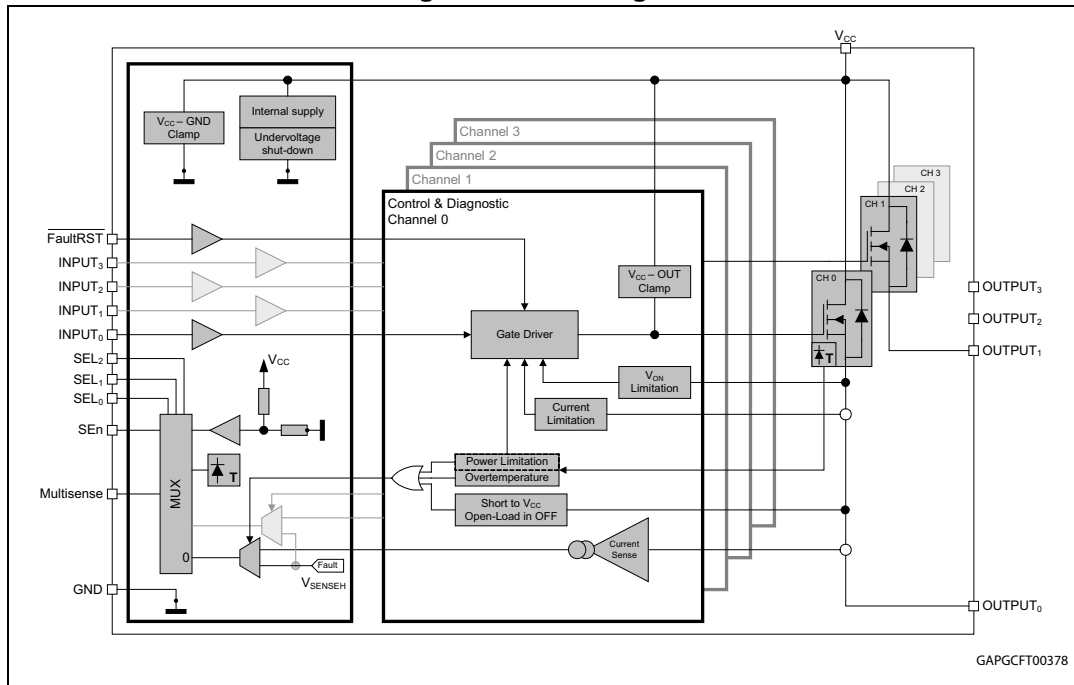

Table 1. Pin functions

Name	Function
V _{CC}	Battery connection.
OUTPUT _{0,1,2,3}	Power output.
GND	Ground connection. Must be reverse battery protected by an external diode / resistor network.
INPUT _{0,1,2,3}	Voltage controlled input pin with hysteresis, compatible with 3 V and 5 V CMOS outputs. It controls output switch state.
MultiSense	Multiplexed analog sense output pin; it delivers a current proportional to the selected diagnostic: load current, supply voltage or chip temperature.
SEN	Active high compatible with 3 V and 5 V CMOS outputs pin; it enables the MultiSense diagnostic pin.
SEL _{0,1,2}	Active high compatible with 3 V and 5 V CMOS outputs pin; they address the MultiSense multiplexer.
$\overline{\text{FaultRST}}$	Active low compatible with 3 V and 5 V CMOS outputs pin; it unlatches the output in case of fault; If kept low, sets the outputs in auto-restart mode.

Figure 2. Configuration diagram (top view)

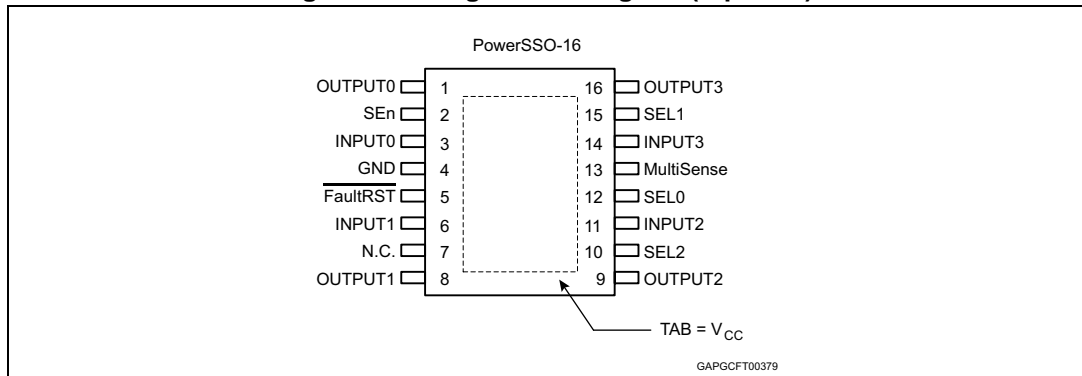

Table 2. Suggested connections for unused and not connected pins

Connection / pin	MultiSense	N.C.	Output	Input	SE _n , SEL _x FaultRST
Floating	Not allowed	X ⁽¹⁾	X	X	X
To ground	Through 1 kΩ resistor	X	Not allowed	Through 15 kΩ resistor	Through 15 kΩ resistor

1. X: do not care.

2 Electrical specification

Figure 3. Current and voltage conventions

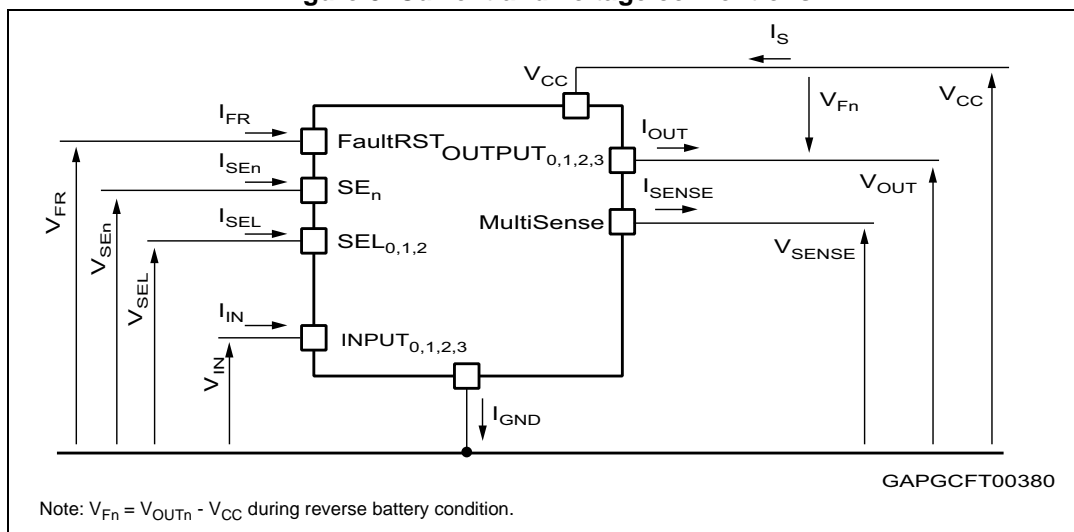

2.1 Absolute maximum ratings

Stressing the device above the rating listed in [Table 3](#) may cause permanent damage to the device. These are stress ratings only and operation of the device at these or any other conditions above those indicated in the operating sections of this specification is not implied. Exposure to the conditions in table below for extended periods may affect device reliability.

Table 3. Absolute maximum ratings

Symbol	Parameter	Value	Unit
V_{CC}	DC supply voltage	38	V
$-V_{CC}$	Reverse DC supply voltage	0.3	
V_{CCPK}	Maximum transient supply voltage (ISO 16750-2:2010 Test B clamped to 40V; $R_L = 4 \Omega$)	40	V
V_{CCJS}	Maximum jump start voltage for single pulse short circuit protection	28	V
$-I_{GND}$	DC reverse ground pin current	200	mA
I_{OUT}	OUTPUT _{0,1,2,3} DC output current	Internally limited	A
$-I_{OUT}$	Reverse DC output current	4	
I_{IN}	INPUT _{0,1,2,3} DC input current	-1 to 10	mA
I_{SEn}	SEn DC input current		
I_{SEL}	SEL _{0,1,2} DC input current		
I_{FR}	FaultRST DC input current		
V_{FR}	FaultRST DC input voltage	7.5	V

Table 3. Absolute maximum ratings (continued)

Symbol	Parameter	Value	Unit
I _{SENSE}	MultiSense pin DC output current (V _{GND} = V _{CC} and V _{SENSE} < 0 V)	10	mA
	MultiSense pin DC output current in reverse (V _{CC} < 0 V)	-20	
E _{MAX}	Maximum switching energy (single pulse) (T _{DEMAG} = 0.4 ms; T _{jstart} = 150 °C)	10	mJ
V _{ESD}	Electrostatic discharge (JEDEC 22A-114F)		
	– INPUT _{0,1,2,3}	4000	V
	– MultiSense	2000	V
	– SEn, SEL _{0,1,2} , FaultRST	4000	V
	– OUTPUT _{0,1,2,3}	4000	V
– V _{CC}	4000	V	
V _{ESD}	Charge device model (CDM-AEC-Q100-011)	750	V
T _j	Junction operating temperature	-40 to 150	°C
T _{stg}	Storage temperature	-55 to 150	

2.2 Thermal data

Table 4. Thermal data

Symbol	Parameter	Typ. value	Unit
R _{thj-board}	Thermal resistance junction-board (JEDEC JESD 51-5 / 51-8) ⁽¹⁾⁽²⁾	7.7	°C/W
R _{thj-amb}	Thermal resistance junction-ambient (JEDEC JESD 51-5) ⁽¹⁾⁽³⁾	61	
R _{thj-amb}	Thermal resistance junction-ambient (JEDEC JESD 51-7) ⁽¹⁾⁽²⁾	26.8	

- One channel ON.
- Device mounted on four-layers 2s2p PCB.
- Device mounted on two-layers 2s0p PCB with 2 cm² heatsink copper trace.

2.3 Main electrical characteristics

7 V < V_{CC} < 28 V; -40°C < T_j < 150°C, unless otherwise specified.

All typical values refer to V_{CC} = 13 V; T_j = 25°C, unless otherwise specified.

Table 5. Power section

Symbol	Parameter	Test conditions	Min.	Typ.	Max.	Unit
V _{CC}	Operating supply voltage		4	13	28	V
V _{USD}	Undervoltage shutdown				4	
V _{USDReset}	Undervoltage shutdown reset				5	
V _{USDhyst}	Undervoltage shutdown hysteresis			0.3		
R _{ON}	On-state resistance ⁽¹⁾	I _{OUT} = 1 A; T _j = 25°C		140		mΩ
		I _{OUT} = 1 A; T _j = 150°C			280	
		I _{OUT} = 1 A; V _{CC} = 4 V; T _j = 25°C			210	
V _{clamp}	Clamp voltage	I _S = 20 mA; T _j = -40°C	38			V
		I _S = 20 mA; 25°C < T _j < 150°C	41	46	52	
I _{STBY}	Supply current in standby at V _{CC} = 13 V ⁽²⁾	V _{CC} = 13 V; V _{IN} = V _{OUT} = V _{FR} = V _{SEn} = 0 V; V _{SELO,1,2} = 0 V; T _j = 25°C			0.5	μA
		V _{CC} = 13 V; V _{IN} = V _{OUT} = V _{FR} = V _{SEn} = 0 V; V _{SELO,1,2} = 0 V; T _j = 85°C ⁽³⁾			0.5	μA
		V _{CC} = 13 V; V _{IN} = V _{OUT} = V _{FR} = V _{SEn} = 0 V; V _{SELO,1,2} = 0 V; T _j = 125°C			3	μA
t _{D_STBY}	Standby mode blanking time	V _{CC} = 13 V; V _{IN} = V _{OUT} = V _{FR} = V _{SELO,1,2} = 0 V; V _{SEn} = 5 V to 0 V	60	300	550	μs
I _{S(ON)}	Supply current	V _{CC} = 13 V; V _{SEn} = V _{FR} = V _{SELO,1,2} = 0 V; V _{IN0,1,2,3} = 5 V; I _{OUT0,1,2,3} = 0 A		10	16	mA
I _{GND(ON)}	Control stage current consumption in ON state. All channels active.	V _{CC} = 13 V; V _{SEn} = 5 V; V _{FR} = V _{SELO,1,2} = 0 V; V _{IN0,1,2,3} = 5 V; I _{OUT0,1,2,3} = 1 A			20	mA
I _{L(off)}	Off-state output current at V _{CC} = 13 V ⁽¹⁾	V _{IN} = V _{OUT} = 0 V; V _{CC} = 13 V; T _j = 25°C	0	0.01	0.5	μA
		V _{IN} = V _{OUT} = 0 V; V _{CC} = 13 V; T _j = 125°C	0		3	
V _F	Output - V _{CC} diode voltage ⁽¹⁾	I _{OUT} = -1 A; T _j = 150°C			0.7	V

1. For each channel.
2. PowerMOS leakage included.
3. Parameter specified by design; not subject to production test.

Table 6. Switching ($V_{CC} = 13\text{ V}$; $-40^{\circ}\text{C} < T_j < 150^{\circ}\text{C}$, unless otherwise specified)⁽¹⁾

Symbol	Parameter	Test conditions	Min.	Typ.	Max.	Unit
$t_{d(on)}$	Turn-on delay time at $T_j = 25^{\circ}\text{C}$	$R_L = 13\ \Omega$	10	70	120	μs
$t_{d(off)}$	Turn-off delay time at $T_j = 25^{\circ}\text{C}$		10	40	100	
$(dV_{OUT}/dt)_{on}$	Turn-on voltage slope at $T_j = 25^{\circ}\text{C}$	$R_L = 13\ \Omega$	0.1	0.29	0.7	$\text{V}/\mu\text{s}$
$(dV_{OUT}/dt)_{off}$	Turn-off voltage slope at $T_j = 25^{\circ}\text{C}$		0.1	0.35	0.7	
W_{ON}	Switching energy losses at turn-on (t_{won})	$R_L = 13\ \Omega$	—	0.15	0.2 ⁽²⁾	mJ
W_{OFF}	Switching energy losses at turn-off (t_{woff})	$R_L = 13\ \Omega$	—	0.1	0.18 ⁽²⁾	mJ
t_{SKEW}	Differential Pulse skew ($t_{PHL} - t_{PLH}$) see Figure 6	$R_L = 13\ \Omega$	-90	-40	10	μs

1. See [Figure 6: Switching time and Pulse skew](#).

2. Parameter guaranteed by design and characterization; not subject to production test.

Table 7. Logic Inputs ($7\text{ V} < V_{CC} < 28\text{ V}$; $-40^{\circ}\text{C} < T_j < 150^{\circ}\text{C}$)

Symbol	Parameter	Test conditions	Min.	Typ.	Max.	Unit
INPUT_{0,1,2,3} characteristics						
V_{IL}	Input low level voltage				0.9	V
I_{IL}	Low level input current	$V_{IN} = 0.9\text{ V}$	1			μA
V_{IH}	Input high level voltage		2.1			V
I_{IH}	High level input current	$V_{IN} = 2.1\text{ V}$			10	μA
$V_{I(hyst)}$	Input hysteresis voltage		0.2			V
V_{ICL}	Input clamp voltage	$I_{IN} = 1\text{ mA}$	5.3		7.2	V
		$I_{IN} = -1\text{ mA}$		-0.7		
FaultRST characteristics						
V_{FRL}	Input low level voltage				0.9	V
I_{FRL}	Low level input current	$V_{IN} = 0.9\text{ V}$	1			μA
V_{FRH}	Input high level voltage		2.1			V
I_{FRH}	High level input current	$V_{IN} = 2.1\text{ V}$			10	μA
$V_{FR(hyst)}$	Input hysteresis voltage		0.2			V
V_{FRCL}	Input clamp voltage	$I_{IN} = 1\text{ mA}$	5.3		7.5	V
		$I_{IN} = -1\text{ mA}$		-0.7		
SEL_{0,1,2} characteristics ($7\text{ V} < V_{CC} < 18\text{ V}$)						
V_{SELL}	Input low level voltage				0.9	V
I_{SELL}	Low level input current	$V_{IN} = 0.9\text{ V}$	1			μA
V_{SELH}	Input high level voltage		2.1			V

Table 7. Logic Inputs (7 V < V_{CC} < 28 V; -40°C < T_j < 150°C) (continued)

Symbol	Parameter	Test conditions	Min.	Typ.	Max.	Unit
I _{SELH}	High level input current	V _{IN} = 2.1 V			10	μA
V _{SEL(hyst)}	Input hysteresis voltage		0.2			V
V _{SELCL}	Input clamp voltage	I _{IN} = 1 mA	5.3		7.2	V
		I _{IN} = -1 mA		-0.7		
SEn characteristics (7 V < V_{CC} < 18 V)						
V _{SEnL}	Input low level voltage				0.9	V
I _{SEnL}	Low level input current	V _{IN} = 0.9 V	1			μA
V _{SEnH}	Input high level voltage		2.1			V
I _{SEnH}	High level input current	V _{IN} = 2.1 V			10	μA
V _{SEn(hyst)}	Input hysteresis voltage		0.2			V
V _{SEnCL}	Input clamp voltage	I _{IN} = 1 mA	5.3		7.2	V
		I _{IN} = -1 mA		-0.7		

Table 8. Protections (7 V < V_{CC} < 18 V; -40°C < T_j < 150°C)

Symbol	Parameter	Test conditions	Min.	Typ.	Max.	Unit
I _{LIMH}	DC short circuit current	V _{CC} = 13 V	8	12	16	A
		4 V < V _{CC} < 18 V ⁽¹⁾			16	
I _{LIML}	Short circuit current during thermal cycling	V _{CC} = 13 V; T _R < T _j < T _{TSD}		4		
T _{TSD}	Shutdown temperature		150	175	200	°C
T _R	Reset temperature ⁽¹⁾		T _{RS} + 1	T _{RS} + 7		
T _{RS}	Thermal reset of fault diagnostic indication	V _{FR} = 0 V; V _{SEn} = 5 V	135			
T _{HYST}	Thermal hysteresis (T _{TSD} - T _R) ⁽¹⁾			7		
ΔT _{J_SD}	Dynamic temperature	T _j = -40°C; V _{CC} = 13 V		60		K
t _{LATCH_RST} ⁽¹⁾	Fault reset time for output unlatch	V _{FR} = 5 V to 0 V; V _{SEn} = 5 V – E.g. Ch ₀ V _{IN0} = 5 V; V _{SEL0,1,2} = 0 V	3	10	20	μs
V _{DEMAG}	Turn-off output voltage clamp	I _{OUT} = 1 A; L = 6 mH; T _j = -40°C	V _{CC} - 38			V
		I _{OUT} = 1 A; L = 6 mH; T _j = 25°C to 150°C	V _{CC} - 41	V _{CC} - 46	V _{CC} - 52	V
V _{ON}	Output voltage drop limitation	I _{OUT} = 0.07 A		20		mV

1. Parameter guaranteed by design and characterization; not subject to production test.

Table 9. MultiSense (7 V < V_{CC} < 18 V; -40°C < T_j < 150°C)

Symbol	Parameter	Test conditions	Min.	Typ.	Max.	Unit
V _{SENSE_CL}	MultiSense clamp voltage	V _{SEn} = 0 V; I _{SENSE} = 1 mA	-17		-12	V
		V _{SEn} = 0 V; I _{SENSE} = -1 mA		7		
Current Sense characteristics						
K _{OL}	I _{OUT} /I _{SENSE}	I _{OUT} = 0.01 A; V _{SENSE} = 0.5 V; V _{SEn} = 5 V	330			
dK _{cal} /K _{cal} ⁽¹⁾⁽²⁾	Current sense ratio drift at calibration point	I _{OUT} = 0.01 A to 0.025 A; I _{cal} = 17.5 mA; V _{SENSE} = 0.5 V; V _{SEn} = 5 V	-30		30	%
K _{LED}	I _{OUT} /I _{SENSE}	I _{OUT} = 0.025 A; V _{SENSE} = 0.5 V; V _{SEn} = 5 V	330	580	830	
dK _{LED} /K _{LED} ⁽¹⁾⁽²⁾	Current sense ratio drift	I _{OUT} = 0.025 A; V _{SENSE} = 0.5 V; V _{SEn} = 5 V	-25		25	%
K ₀	I _{OUT} /I _{SENSE}	I _{OUT} = 0.070 A; V _{SENSE} = 0.5 V; V _{SEn} = 5 V	375	550	720	
dK ₀ /K ₀ ⁽¹⁾⁽²⁾	Current sense ratio drift	I _{OUT} = 0.070 A; V _{SENSE} = 0.5 V; V _{SEn} = 5 V	-20		20	%
K ₁	I _{OUT} /I _{SENSE}	I _{OUT} = 0.15 A; V _{SENSE} = 4 V; V _{SEn} = 5 V	365	520	675	
dK ₁ /K ₁ ⁽¹⁾⁽²⁾	Current sense ratio drift	I _{OUT} = 0.15 A; V _{SENSE} = 4 V; V _{SEn} = 5 V	-15		15	%
K ₂	I _{OUT} /I _{SENSE}	I _{OUT} = 0.7 A; V _{SENSE} = 4 V; V _{SEn} = 5 V	380	475	570	
dK ₂ /K ₂ ⁽¹⁾⁽²⁾	Current sense ratio drift	I _{OUT} = 0.7 A; V _{SENSE} = 4 V; V _{SEn} = 5 V	-10		10	%
K ₃	I _{OUT} /I _{SENSE}	I _{OUT} = 2 A; V _{SENSE} = 4 V; V _{SEn} = 5 V	420	470	520	
dK ₃ /K ₃ ⁽¹⁾⁽²⁾	Current sense ratio drift	I _{OUT} = 2 A; V _{SENSE} = 4 V; V _{SEn} = 5 V	-5		5	%

Table 9. MultiSense (7 V < V_{CC} < 18 V; -40°C < T_j < 150°C) (continued)

Symbol	Parameter	Test conditions	Min.	Typ.	Max.	Unit
I _{SENSE0}	MultiSense leakage current	MultiSense disabled: V _{SEn} = 0 V	0		0.5	μA
		MultiSense disabled: -1 V < V _{SENSE} < 5 V ⁽¹⁾	-0.5		0.5	
		MultiSense enabled: V _{SEn} = 5 V All channels ON; I _{OUTX} = 0 A; Ch _X diagnostic selected: – E.g. Ch ₀ : V _{IN0,1,2,3} = 5 V; V _{SEL0} = 0 V; V _{SEL1,2} = 0 V; I _{OUT0} = 0 A; I _{OUT1,2,3} = 1 A	0		2	
		MultiSense enabled: V _{SEn} = 5 V; Ch _X OFF; Ch _X diagnostic selected: – E.g. Ch ₀ : V _{IN0} = 0 V; V _{IN1,2,3} = 0 V; V _{SEL0} = 5V; V _{SEL1,2} = 0 V; I _{OUT1,2,3} = 1 A	0		2	
V _{OUT_MSD} ⁽¹⁾	Output Voltage for MultiSense shutdown	V _{SEn} = 5 V; R _{SENSE} = 2.7 kΩ – E.g. Ch ₀ : V _{IN0} = 5 V; V _{SEL0,1,2} = 0 V; I _{OUT0} = 1 A		5		V
V _{SENSE_SAT}	Multisense saturation voltage	V _{CC} = 7 V; R _{SENSE} = 2.7 K; V _{SEn} = 5 V; V _{IN0} = 5 V; V _{SEL0,1,2} = 0 V; I _{OUT0} = 2 A; T _j = 150°C	5			V
I _{SENSE_SAT} ⁽¹⁾	CS saturation current	V _{CC} = 7 V; V _{SENSE} = 4 V; V _{IN0} = 5 V; V _{SEn} = 5 V; V _{SEL0,1,2} = 0 V; T _j = 150°C	4			mA
I _{OUT_SAT} ⁽¹⁾	Output saturation current	V _{CC} = 7 V; V _{SENSE} = 4 V; V _{IN0} = 5 V; V _{SEn} = 5 V; V _{SEL0,1,2} = 0 V; T _j = 150°C	2.2			A
OFF-state diagnostic						
V _{OL}	OFF-state open-load voltage detection threshold	V _{SEn} = 5 V; Ch _X OFF; Ch _X diagnostic selected – E.g. Ch ₀ V _{IN0} = 0 V; V _{SEL0,1,2} = 0 V	2	3	4	V
I _{L(off2)}	OFF-state output sink current	V _{IN} = 0 V; V _{OUT} = V _{OL} ; T _j = -40°C to 125°C	-100		-15	μA

Table 9. MultiSense (7 V < V_{CC} < 18 V; -40°C < T_j < 150°C) (continued)

Symbol	Parameter	Test conditions	Min.	Typ.	Max.	Unit
t _{DSTKON}	OFF-state diagnostic delay time from falling edge of INPUT (see Figure 9)	V _{SEn} = 5 V; Ch _X ON to OFF transition; Ch _X diagnostic selected: – E.g: Ch ₀ V _{IN0} = 5 V to 0 V; V _{SELO,1,2} = 0 V; V _{OUT0} = 4 V; I _{OUT0} = 0 A	100	350	700	μs
t _{D_OL_V}	Settling time for valid OFF-state open load diagnostic indication from rising edge of SE _n	V _{IN0,1,2,3} = 0 V; V _{FR} = 0 V; V _{SELO,1,2} = 0 V; V _{OUT0} = 4 V; V _{SEn} = 0 V to 5 V			60	μs
t _{D_VOL}	OFF-state diagnostic delay time from rising edge of V _{OUT}	V _{SEn} = 5 V; Ch _X OFF; Ch _X diagnostic selected: – E.g: Ch ₀ V _{IN0} = 0 V; V _{SELO,1,2} = 0 V; V _{OUT0} = 0 V to 4 V		5	30	μs
Chip temperature analog feedback						
V _{SENSE_TC}	MultiSense output voltage proportional to chip temperature all channels off	V _{SEn} = 5 V; V _{SELO} = 0 V; V _{SEL1,2} = 5 V; V _{IN0,1,2,3} = 0 V; R _{SENSE} = 1 KΩ; T _j = -40°C	2.325	2.41	2.495	V
		V _{SEn} = 5 V; V _{SELO} = 0 V; V _{SEL1,2} = 5 V; V _{IN0,1,2,3} = 0 V; R _{SENSE} = 1 KΩ; T _j = 25°C	1.985	2.07	2.155	V
		V _{SEn} = 5 V; V _{SELO} = 0 V; V _{SEL1,2} = 5 V; V _{IN0,1,2,3} = 0 V; R _{SENSE} = 1 KΩ; T _j = 125°C	1.435	1.52	1.605	V
dV _{SENSE_TC} /dT ⁽¹⁾	Temperature coefficient	T _j = -40 °C to 150 °C		-5.5		mV/K
Transfer function	$V_{SENSE_TC}(T) = V_{SENSE_TC}(T_0) + dV_{SENSE_TC} / dT * (T - T_0)$					
V_{CC} supply voltage analog feedback						
V _{SENSE_VCC}	MultiSense output voltage proportional to V _{CC} supply voltage	V _{CC} = 13 V; V _{SEn} = 5 V; V _{IN0,1,2,3} = 0 V; V _{SELO,1,2} = 5 V; R _{SENSE} = 1 KΩ	3.16	3.23	3.3	V
Transfer function ⁽³⁾	$V_{SENSE_VCC} = V_{CC} / 4$					

Table 9. MultiSense (7 V < V_{CC} < 18 V; -40°C < T_j < 150°C) (continued)

Symbol	Parameter	Test conditions	Min.	Typ.	Max.	Unit
Fault diagnostic feedback (see Table 10)						
V _{SENSEH}	MultiSense output voltage in fault condition	V _{CC} = 13 V; R _{SENSE} = 1 kΩ – E.g: Ch ₀ in open load V _{IN0} = 0 V; V _{SEn} = 5 V; V _{SEL0,1,2} = 0 V; I _{OUT0} = 0 A; V _{OUT0} = 4 V	5		6.6	V
I _{SENSEH}	MultiSense output current in fault condition	V _{CC} = 13 V; V _{SENSE} = 5 V	7	20	30	mA
MultiSense timings (current sense mode - see Figure 7)						
t _{DSENSE1H}	Current sense settling time from rising edge of SEn	V _{IN} = 5 V; V _{SEn} = 0 V to 5 V; R _{SENSE} = 1 kΩ; R _L = 13 Ω			60	μs
t _{DSENSE1L}	Current sense disable delay time from falling edge of SEn	V _{IN} = 5 V; V _{SEn} = 0 V to 5 V; R _{SENSE} = 1 kΩ; R _L = 13 Ω		5	20	μs
t _{DSENSE2H}	Current sense settling time from rising edge of INPUT	V _{IN} = 0 V to 5 V; V _{SEn} = 5 V; R _{SENSE} = 1 kΩ; R _L = 13 Ω		100	250	μs
Δt _{DSENSE2H}	Current sense settling time from rising edge of I _{OUT} (dynamic response to a step change of I _{OUT})	V _{IN} = 5 V; V _{SEn} = 5 V; R _{SENSE} = 1 kΩ; I _{SENSE} = 90 % of I _{SENSEMAX} ; R _L = 13 Ω			100	μs
t _{DSENSE2L}	Current sense turn-off delay time from falling edge of INPUT	V _{IN} = 5 V to 0 V; V _{SEn} = 5 V; R _{SENSE} = 1 kΩ; R _L = 13 Ω		50	250	μs
MultiSense timings (chip temperature sense mode - see Figure 8)						
t _{DSENSE3H}	V _{SENSE_TC} settling time from rising edge of SEn	V _{SEn} = 0 V to 5 V; V _{SEL0} = 0 V; V _{SEL1,2} = 5 V; R _{SENSE} = 1 kΩ			60	μs
t _{DSENSE3L}	V _{SENSE_TC} disable delay time from falling edge of SEn	V _{SEn} = 5 V to 0 V; V _{SEL0} = 0 V; V _{SEL1,2} = 5 V; R _{SENSE} = 1 kΩ			20	μs
MultiSense timings (V_{CC} voltage sense mode - see Figure 8)						
t _{DSENSE4H}	V _{SENSE_VCC} settling time from rising edge of SEn	V _{SEn} = 0 V to 5 V; V _{SEL0,1,2} = 5 V; R _{SENSE} = 1 kΩ			60	μs
t _{DSENSE4L}	V _{SENSE_VCC} disable delay time from falling edge of SEn	V _{SEn} = 5 V to 0 V; V _{SEL0,1,2} = 5 V; R _{SENSE} = 1 kΩ			20	μs

Table 9. MultiSense (7 V < V_{CC} < 18 V; -40°C < T_j < 150°C) (continued)

Symbol	Parameter	Test conditions	Min.	Typ.	Max.	Unit
MultiSense timings (multiplexer transition times)⁽⁴⁾						
t _{D_XtoY}	MultiSense transition delay from Ch _X to Ch _Y	V _{IN0} = 5 V; V _{IN1} = 5 V; V _{SEn} = 5 V; V _{SEL1,2} = 0 V; V _{SEL0} = 0 V to 5 V; I _{OUT0} = 0 A; I _{OUT1} = 1 A; R _{SENSE} = 1 kΩ			20	μs
t _{D_CStoTC}	MultiSense transition delay from current sense to T _C sense	V _{IN0} = 5 V; V _{SEn} = 5 V; V _{SEL0,1} = 0 V; V _{SEL2} = 0 V to 5 V; I _{OUT0} = 0.5 A; R _{SENSE} = 1 kΩ			60	μs
t _{D_TCtoCS}	MultiSense transition delay from T _C sense to current sense	V _{IN0} = 5 V; V _{SEn} = 5 V; V _{SEL0,1} = 0 V; V _{SEL2} = 5 V to 0 V; I _{OUT0} = 0.5 A; R _{SENSE} = 1 kΩ			20	μs
t _{D_CStoVCC}	MultiSense transition delay from current sense to V _{CC} sense	V _{IN3} = 5 V; V _{SEn} = 5 V; V _{SEL0,1} = 5 V; V _{SEL2} = 0 V to 5 V; I _{OUT3} = 0.5 A; R _{SENSE} = 1 kΩ			60	μs
t _{D_VCCtoCS}	MultiSense transition delay from V _{CC} sense to current sense to	V _{IN3} = 5 V; V _{SEn} = 5 V; V _{SEL0,1} = 5 V; V _{SEL2} = 5 V to 0 V; I _{OUT3} = 0.5 A; R _{SENSE} = 1 kΩ			20	μs
t _{D_TCtoVCC}	MultiSense transition delay from T _C sense to V _{CC} sense	V _{CC} = 13 V; T _j = 125°C; V _{SEn} = 5 V; V _{SEL1,2} = 5 V; V _{SEL0} = 0 V to 5 V; R _{SENSE} = 1 kΩ			20	μs
t _{D_VCCtoTC}	MultiSense transition delay from V _{CC} sense to T _C sense	V _{CC} = 13 V; T _j = 125°C; V _{SEn} = 5 V; V _{SEL1,2} = 5 V; V _{SEL0} = 5 V to 0 V; R _{SENSE} = 1 kΩ			20	μs
t _{D_CStoVSENSEH}	MultiSense transition delay from stable current sense on Ch _X to V _{SENSEH} on Ch _Y	V _{IN0} = 5 V; V _{IN1} = 0 V; V _{SEn} = 5 V; V _{SEL1,2} = 0 V; V _{SEL0} = 0 V to 5 V; I _{OUT0} = 1 A; V _{OUT1} = 4 V; R _{SENSE} = 1 kΩ			20	μs

1. Parameter specified by design; not subject to production test.
2. All values refer to V_{CC} = 13 V; T_j = 25°C, unless otherwise specified.
3. V_{CC} sensing and T_C sensing are referred to GND potential.
4. Transition delays are measured up to +/- 10% of final conditions.

Figure 4. I_{OUT}/I_{SENSE} versus I_{OUT}

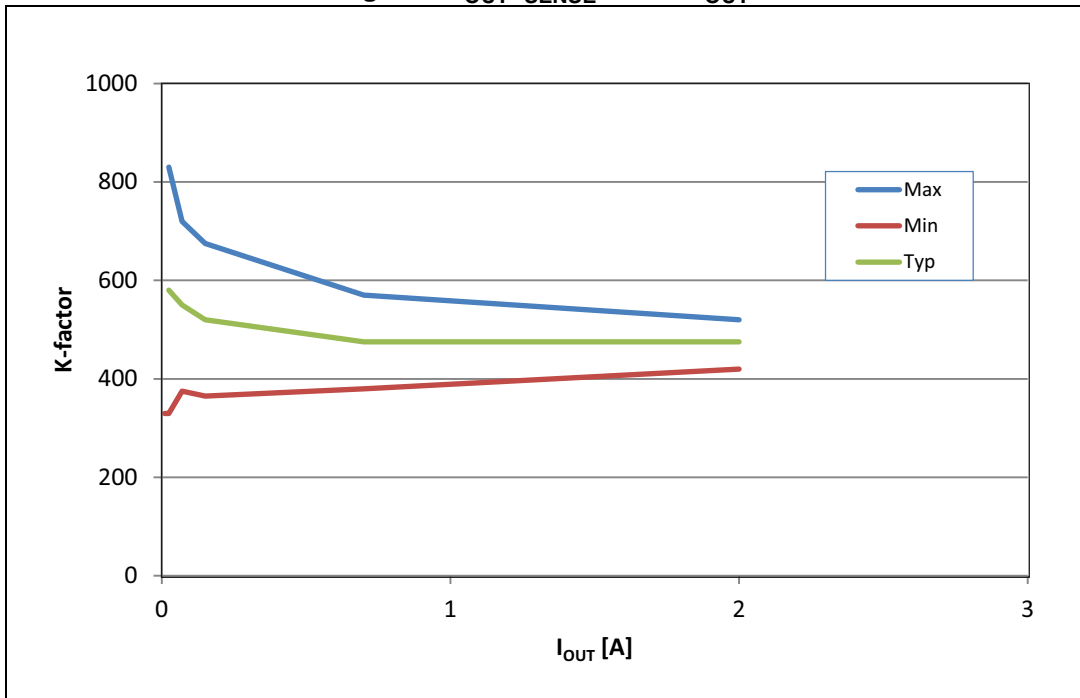
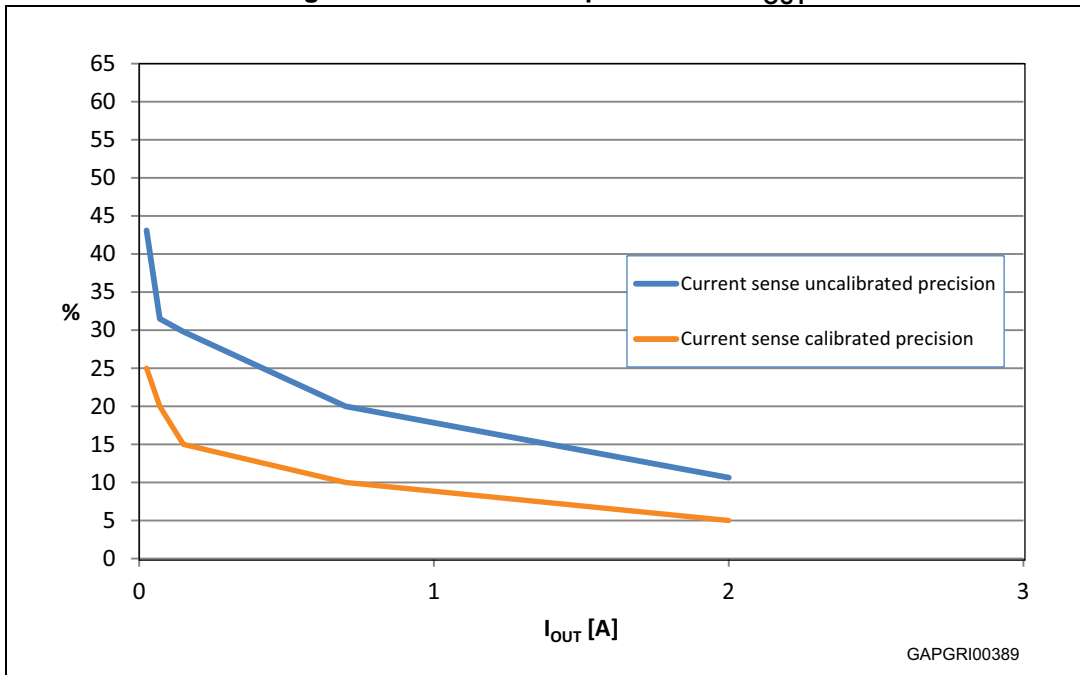

Figure 5. Current sense precision vs. I_{OUT}



GAPGRI00389

Figure 6. Switching time and Pulse skew

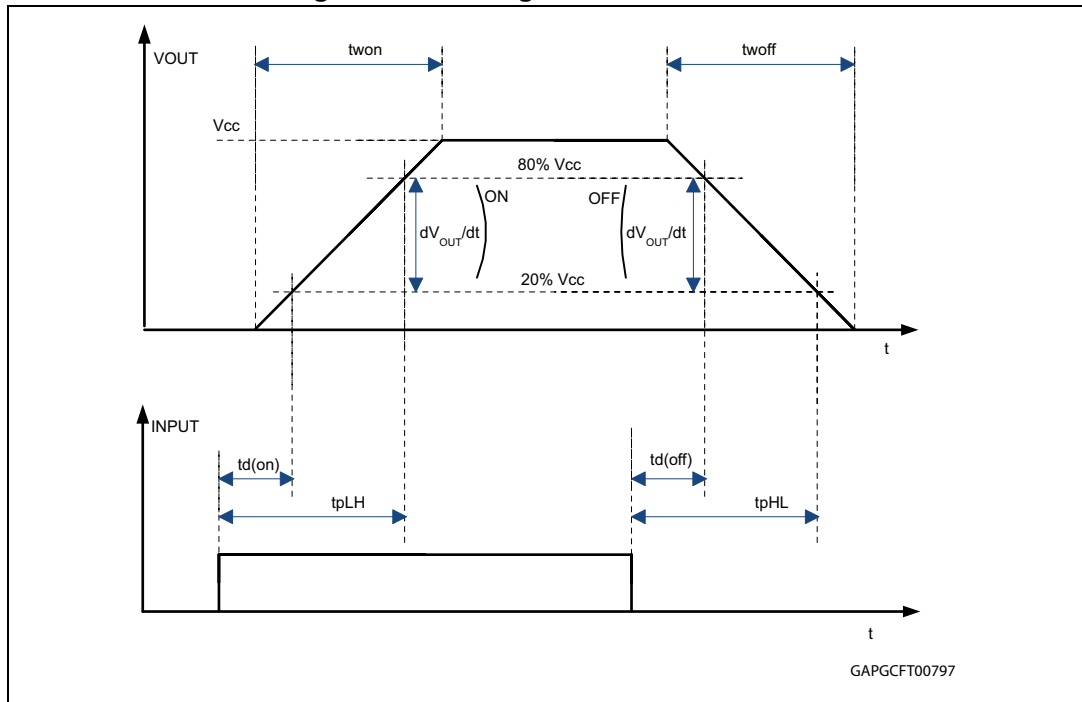

Figure 7. MultiSense timings (current sense mode)

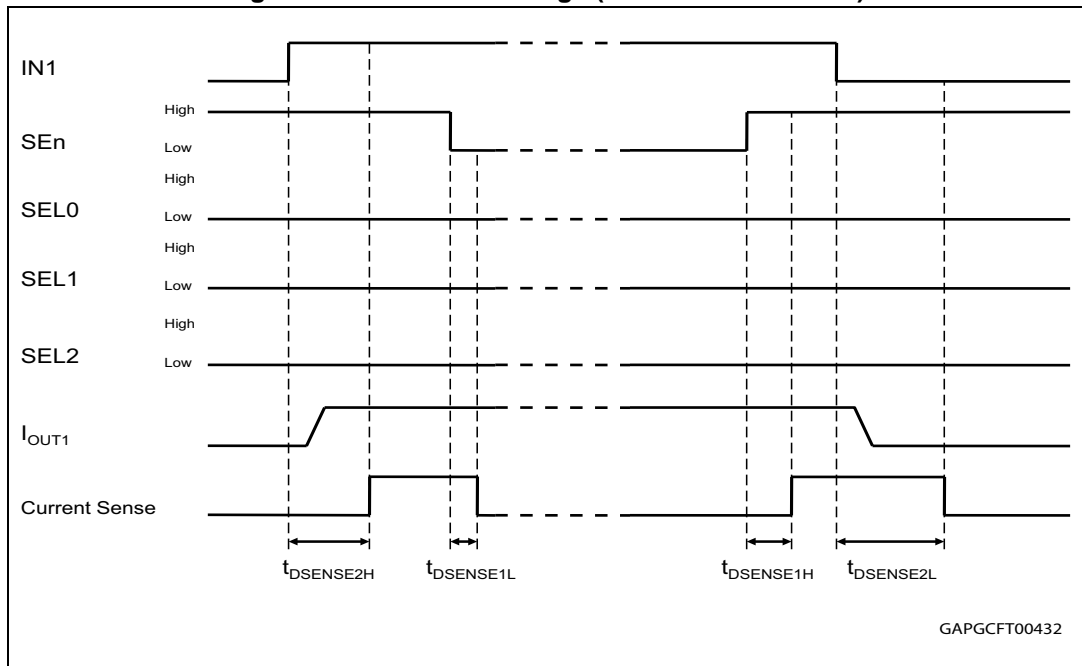

Figure 8. Multisense timings (chip temperature and V_{CC} sense mode)

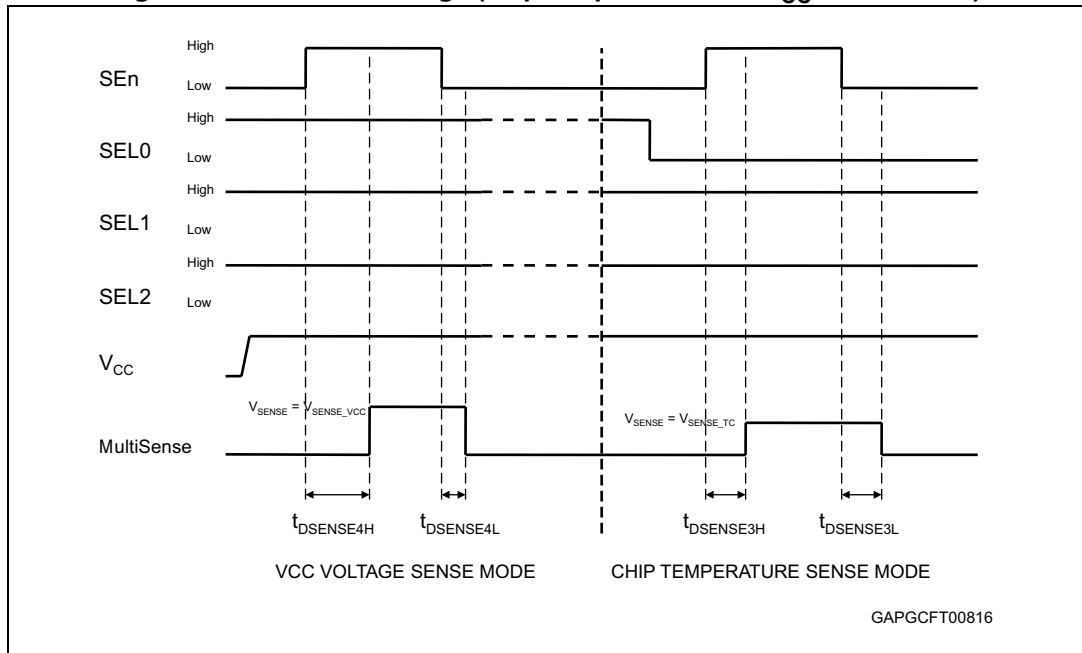

Figure 9. T_{DSTKON}

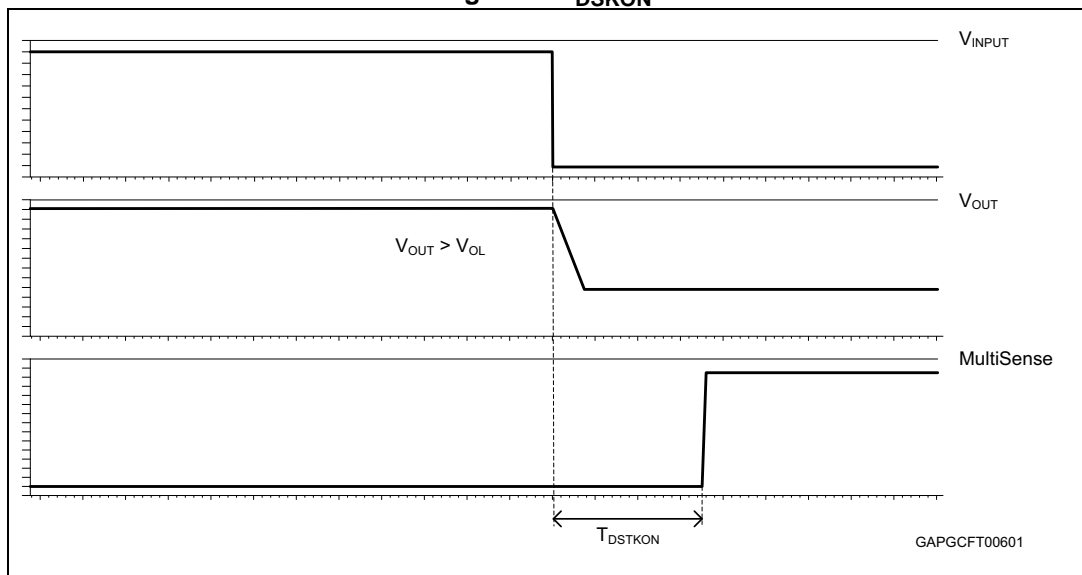

Table 10. Truth table

Mode	Conditions	IN _x	FR	SEn	SEL _x	OUT _x	MultiSense	Comments
Standby	All logic inputs low	L	L	L	L	L	Hi-Z	Low quiescent current consumption
Normal	Nominal load connected; T _j < 150°C	L	X	Refer to Table 11		L	Refer to Table 11	
		H	L			H		Outputs configured for auto-restart
		H	H			H		Outputs configured for Latch-off
Overload	Overload or short to GND causing: T _j > T _{TSD} or ΔT _j > ΔT _{j_SD}	L	X	Refer to Table 11		L	Refer to Table 11	
		H	L			H		Output cycles with temperature hysteresis
		H	H			L		Output latches-off
Under-voltage	V _{CC} < V _{USD} (falling)	X	X	X	X	L L	Hi-Z Hi-Z	Re-start when V _{CC} > V _{USD} + V _{USDhyst} (rising)
OFF-state diagnostics	Short to V _{CC}	L	X	Refer to Table 11		H	Refer to Table 11	
	Open-load	L	X			H		External pull-up
Negative output voltage	Inductive loads turn-off	L	X	Refer to Table 11		< 0 V	Refer to Table 11	

Table 11. MultiSense multiplexer addressing

SEn	SEL ₂	SEL ₁	SEL ₀	MUX channel	MultiSense output			
					Nomal mode	Overload	OFF-state diag. ⁽¹⁾	Negative output
L	X	X	X		Hi-Z			
H	L	L	L	Channel 0 diagnostic	$I_{SENSE} = 1/K * I_{OUT0}$	$V_{SENSE} = V_{SENSEH}$	$V_{SENSE} = V_{SENSEH}$	Hi-Z
H	L	L	H	Channel 1 diagnostic	$I_{SENSE} = 1/K * I_{OUT1}$	$V_{SENSE} = V_{SENSEH}$	$V_{SENSE} = V_{SENSEH}$	Hi-Z
H	L	H	L	Channel 2 diagnostic	$I_{SENSE} = 1/K * I_{OUT2}$	$V_{SENSE} = V_{SENSEH}$	$V_{SENSE} = V_{SENSEH}$	Hi-Z
H	L	H	H	Channel 3 diagnostic	$I_{SENSE} = 1/K * I_{OUT3}$	$V_{SENSE} = V_{SENSEH}$	$V_{SENSE} = V_{SENSEH}$	Hi-Z
H	H	L	L	T _{CHIP} Sense	$V_{SENSE} = V_{SENSE_TC}$			
H	H	L	H	V _{CC} Sense	$V_{SENSE} = V_{SENSE_VCC}$			
H	H	H	L	T _{CHIP} Sense	$V_{SENSE} = V_{SENSE_TC}$			
H	H	H	H	V _{CC} Sense	$V_{SENSE} = V_{SENSE_VCC}$			

1. In case the output channel corresponding to the selected MUX channel is latched off while the relevant input is low, Multisense pin delivers feedback according to OFF-State diagnostic.
 Example 1: FR = 1; IN₀ = 0; OUT₀ = L (latched); MUX channel = channel 0 diagnostic; Mutisense = 0
 Example 2: FR = 1; IN₀ = 0; OUT₀ = latched, V_{OUT0} > V_{OL}; MUX channel = channel 0 diagnostic; Mutisense = V_{SENSEH}

2.4 Waveforms

Figure 10. Latch functionality - behavior in hard short circuit condition ($T_{AMB} \ll T_{TSD}$)

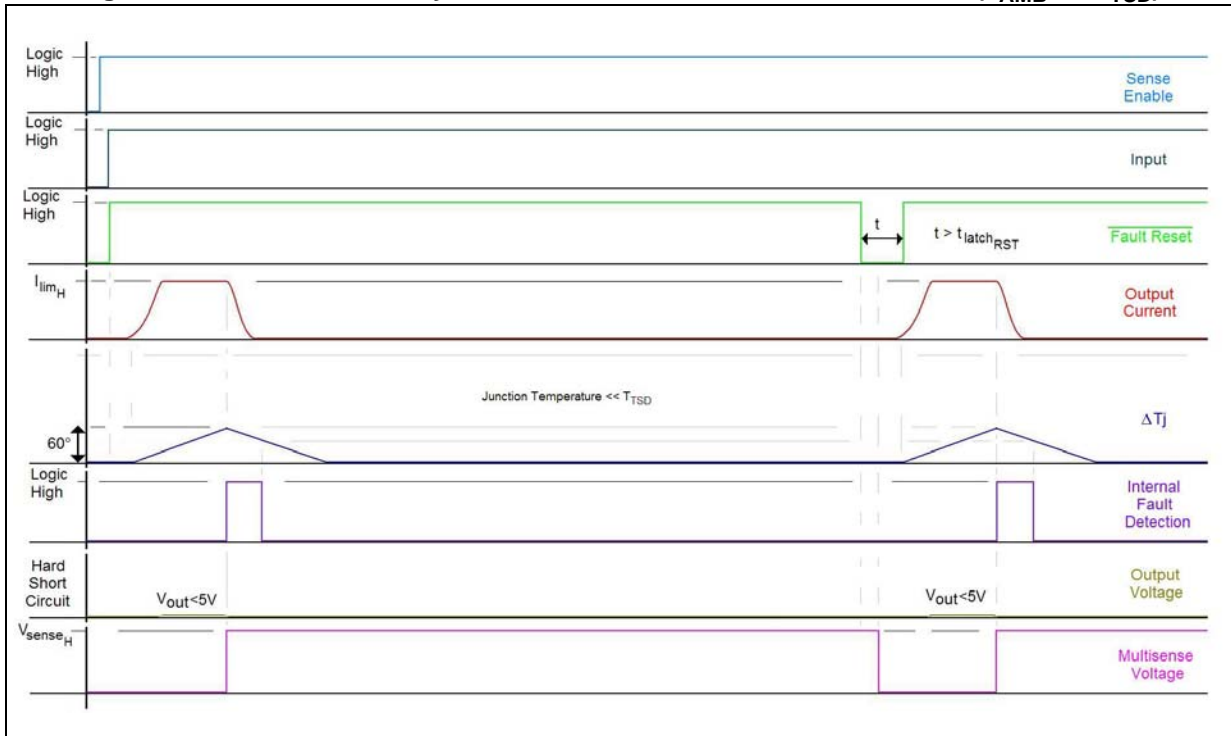

Figure 11. Latch functionality - behavior in hard short circuit condition

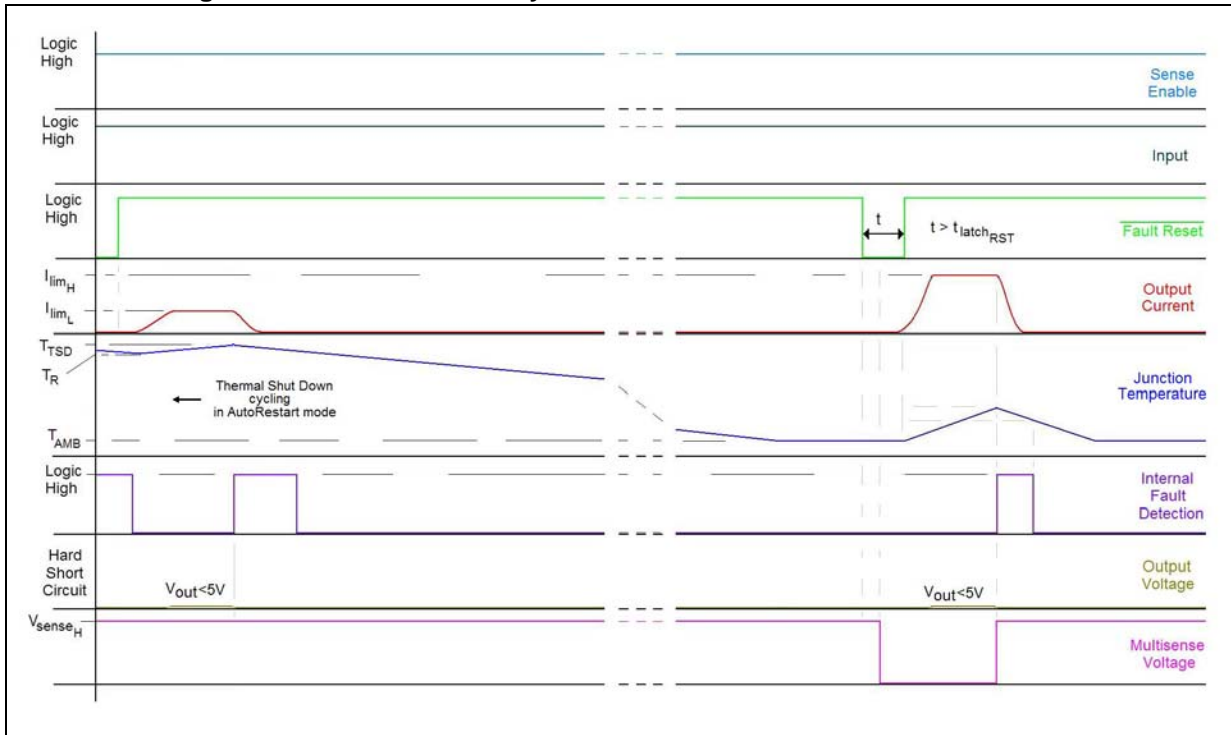

Figure 12. Latch functionality - behavior in hard short circuit condition (autorestart mode + latch off)

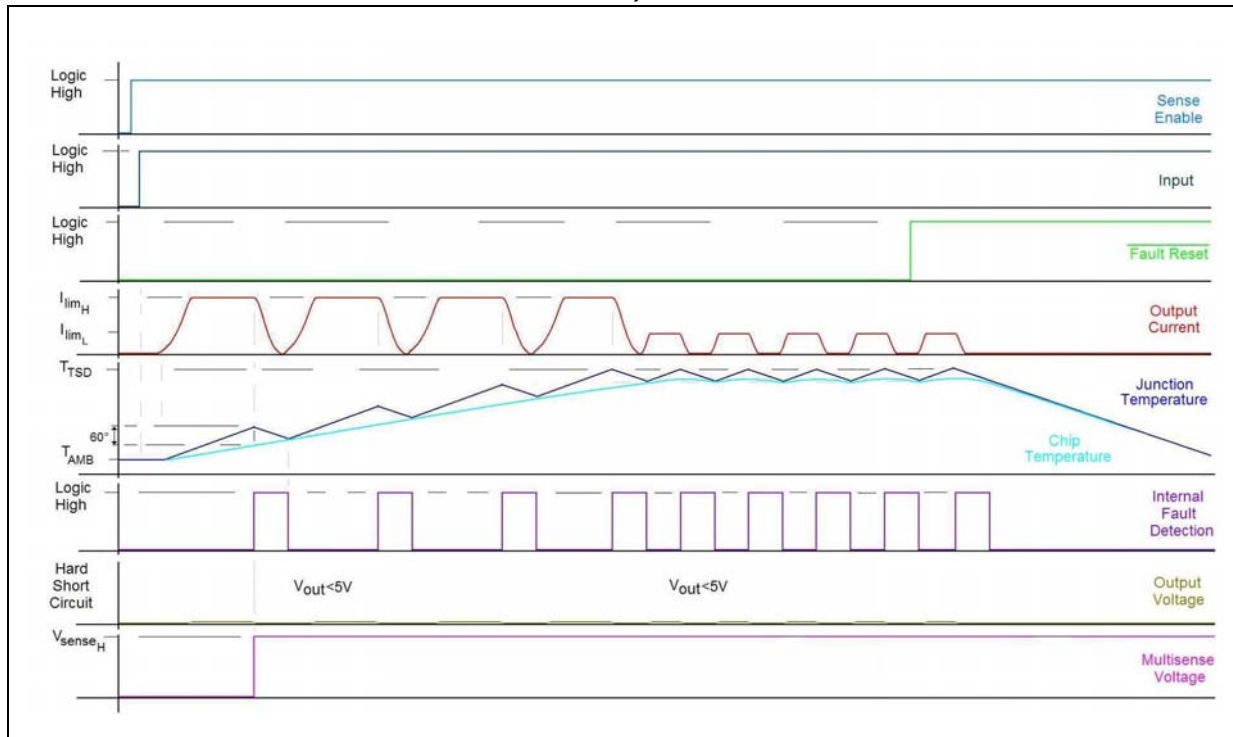

Figure 13. Standby mode activation

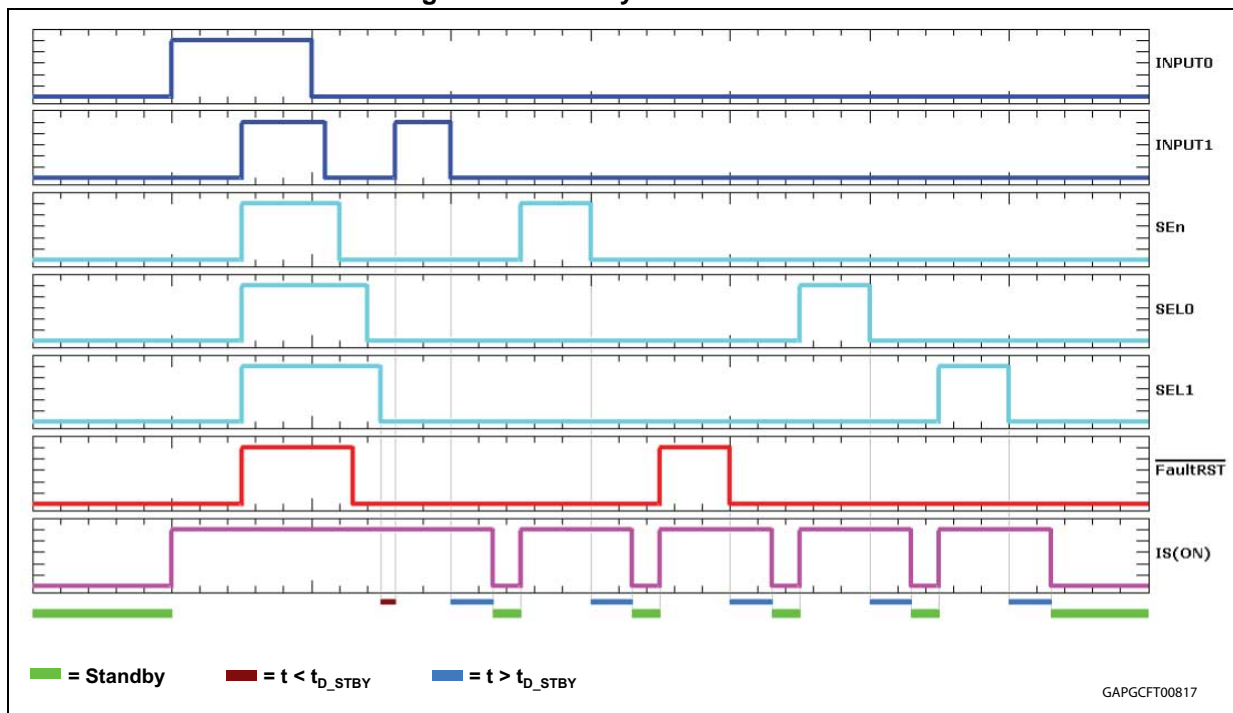
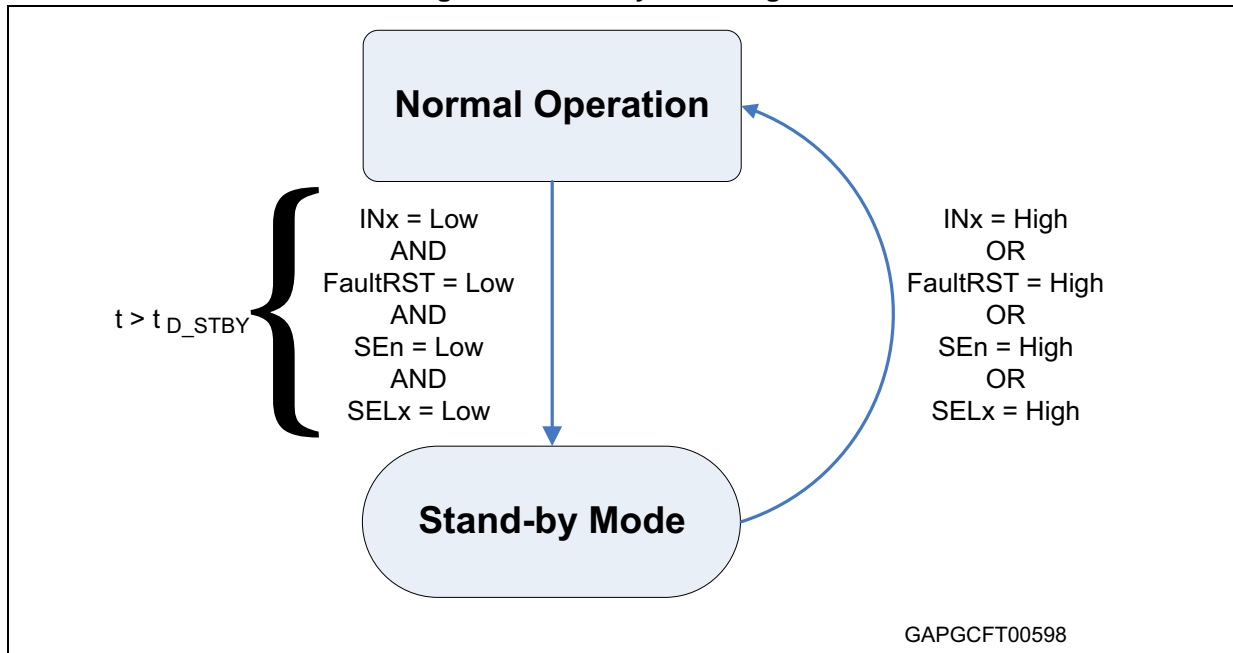

Figure 14. Standby state diagram



2.5 Electrical characteristics curves

Figure 15. OFF-state output current

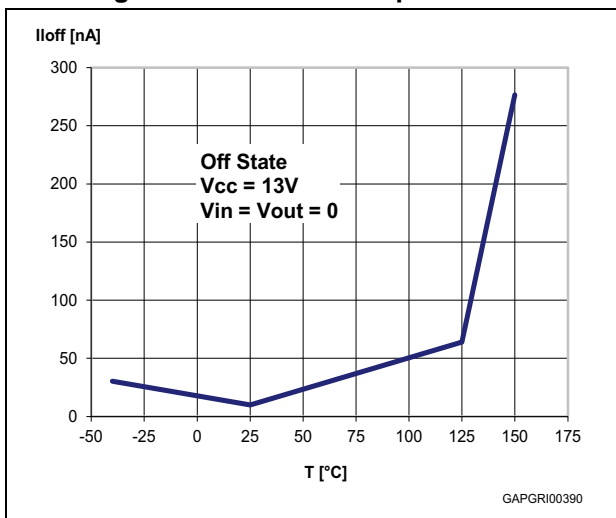

Figure 16. Standby current

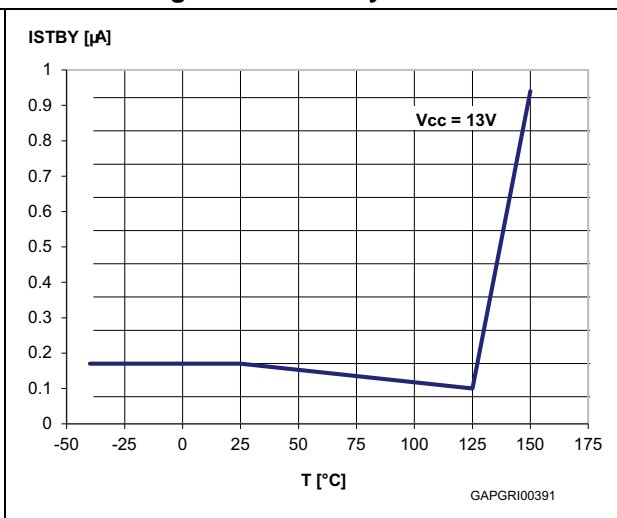

Figure 17. IGND(ON) vs. Iout

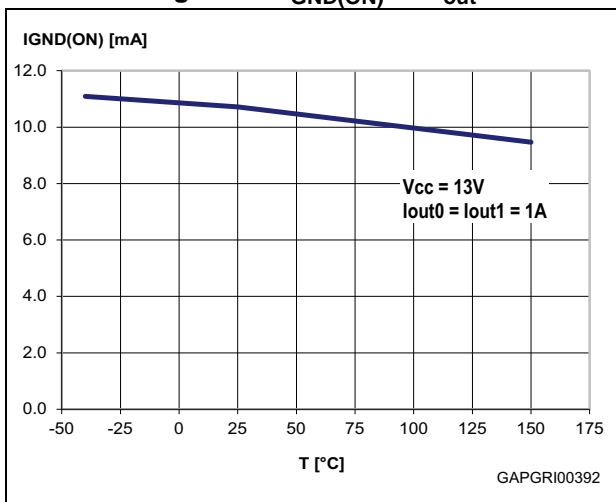

Figure 18. Logic Input high level voltage

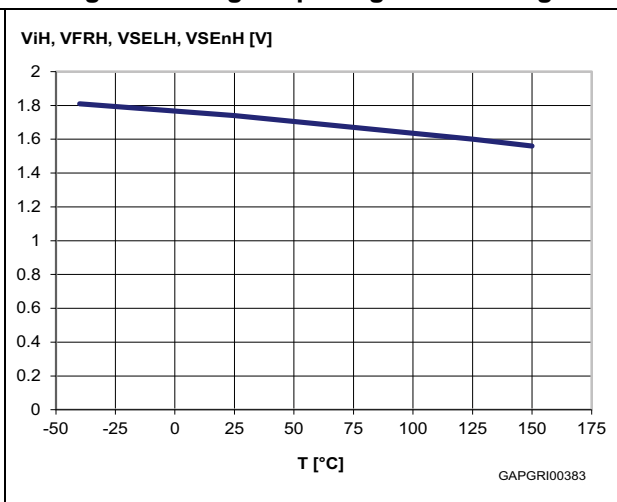

Figure 19. Logic Input low level voltage

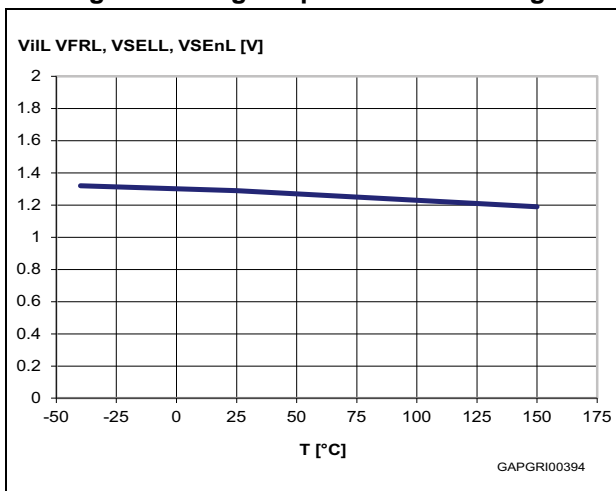

Figure 20. High level logic input current

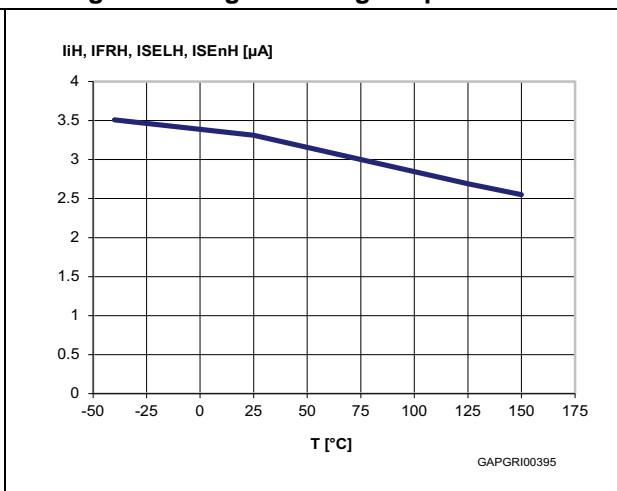

Figure 21. Low level logic input current

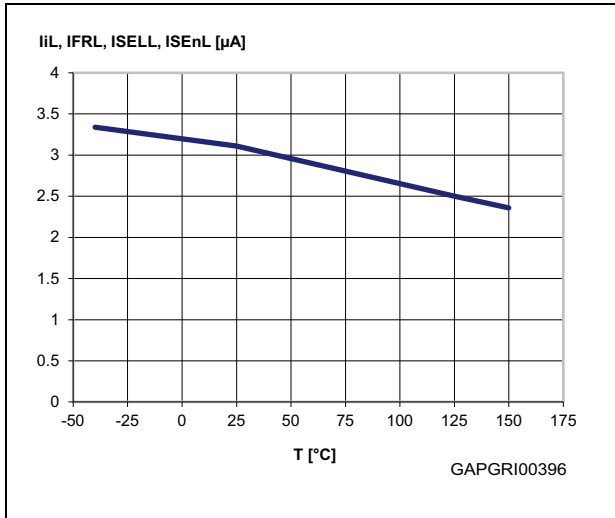

Figure 22. Logic Input hysteresis voltage

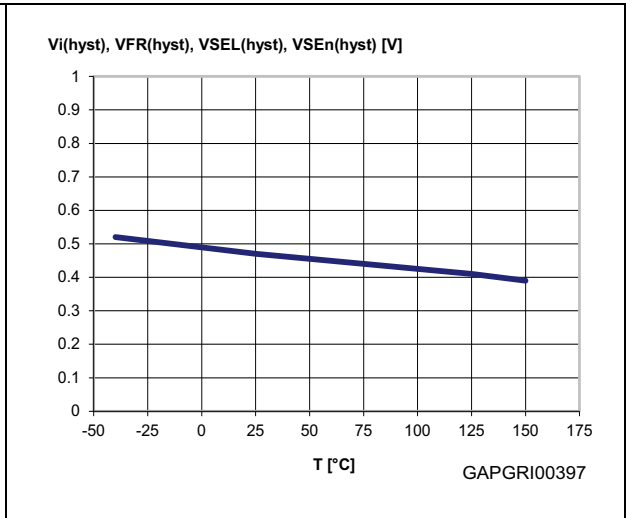

Figure 23. FaultRST Input clamp voltage

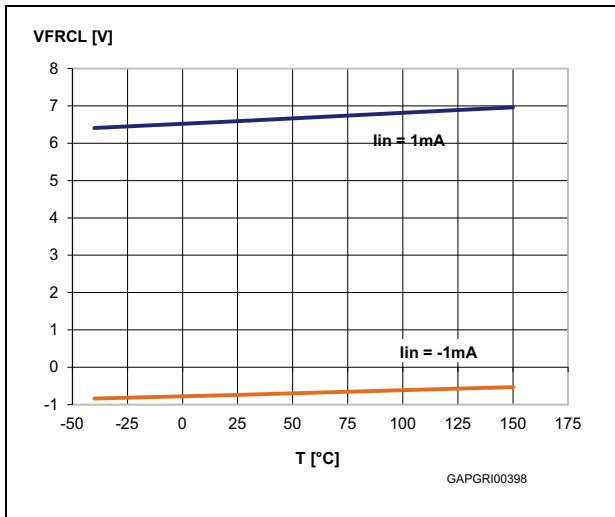

Figure 24. Undervoltage shutdown

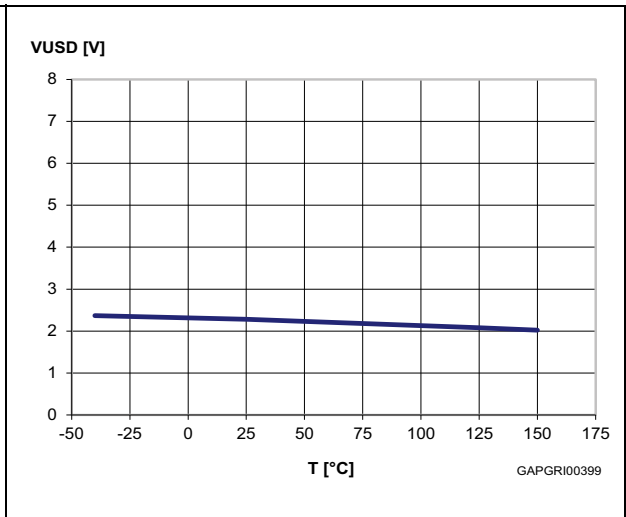

Figure 25. On-state resistance vs. T_{case}

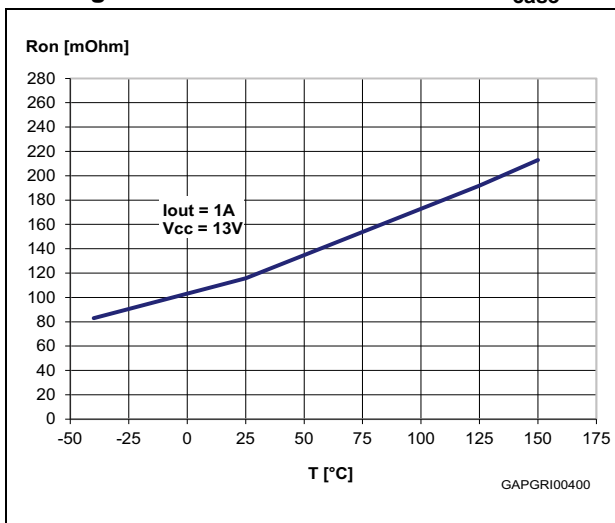

Figure 26. On-state resistance vs. V_{CC}

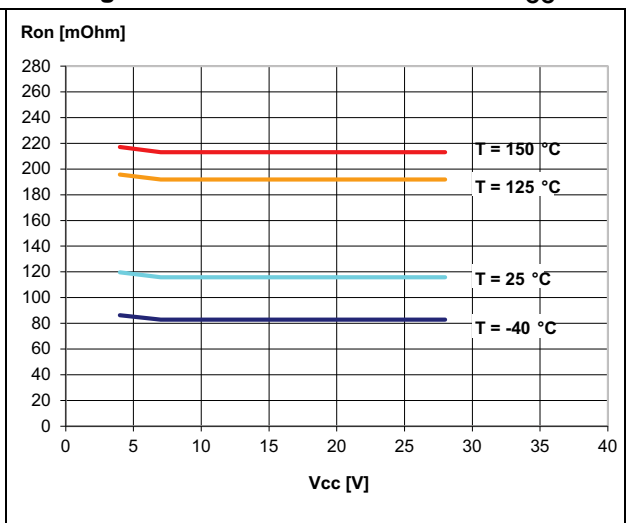

Figure 27. Turn-on voltage slope

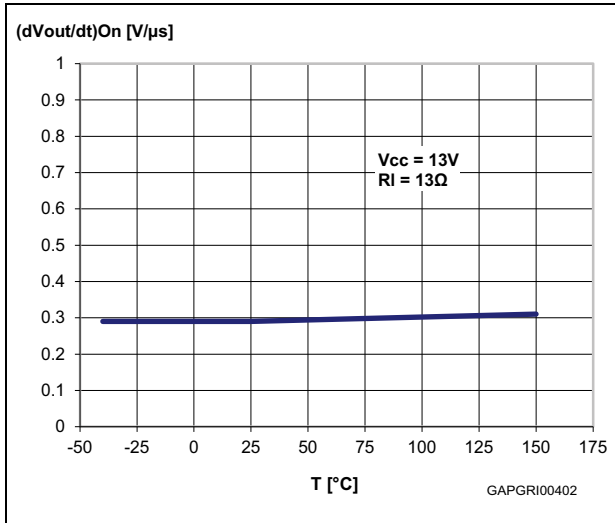

Figure 28. Turn-off voltage slope

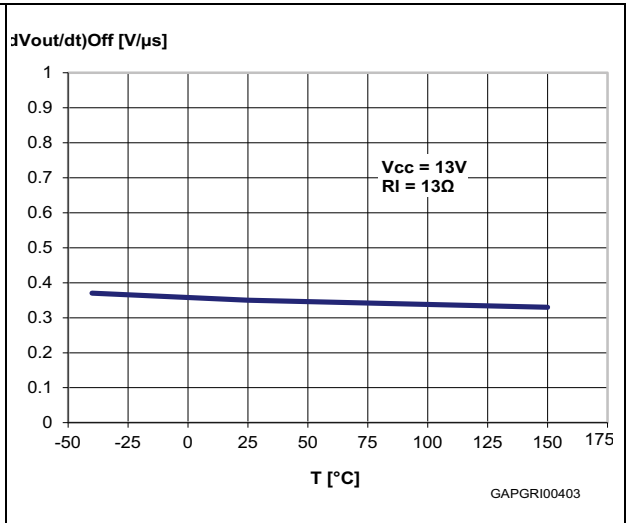

Figure 29. Won vs. T_{case}

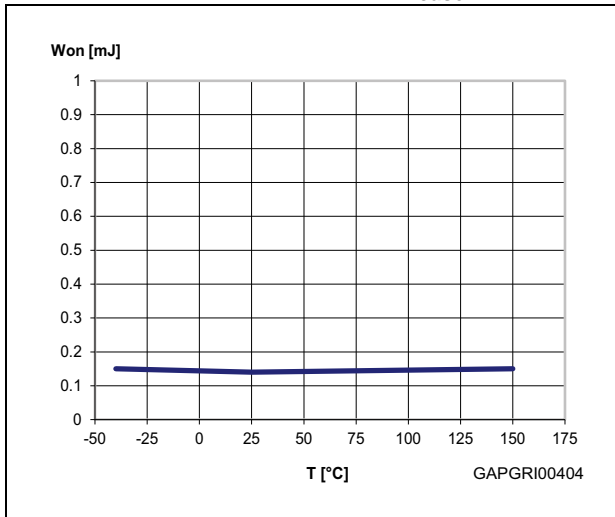

Figure 30. Woff vs. T_{case}

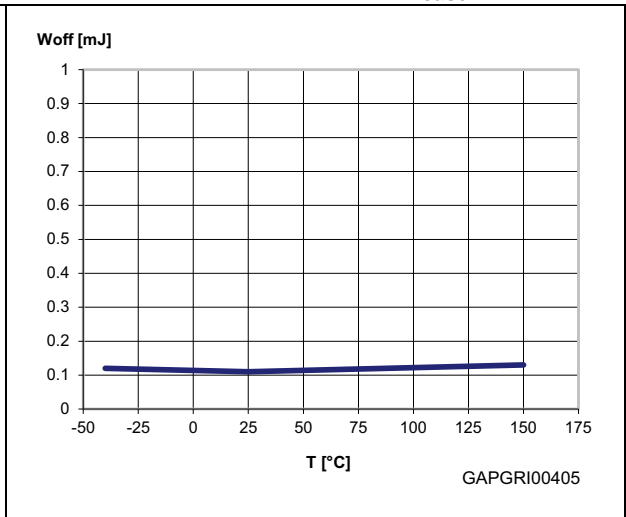

Figure 31. I_{LIMH} vs. T_{case}

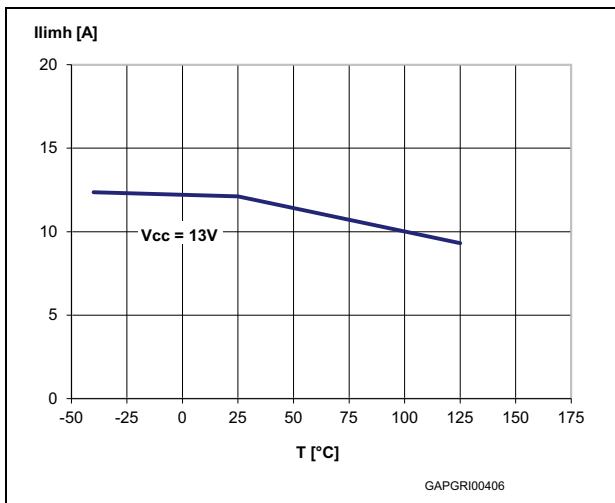

Figure 32. OFF-state open-load voltage detection threshold

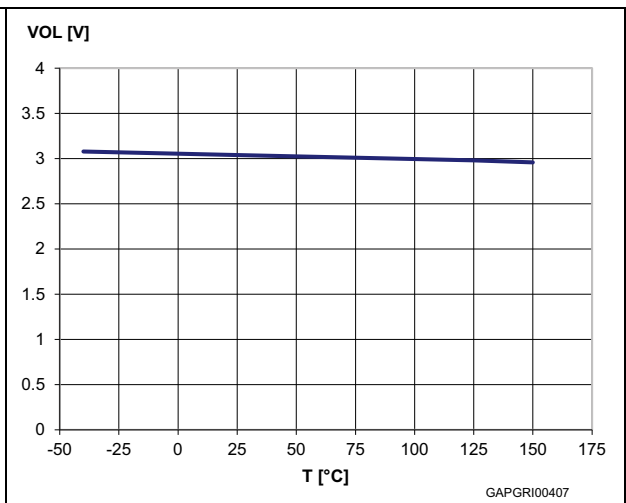

Figure 33. $V_{sense\ clamp}$ vs. T_{case}

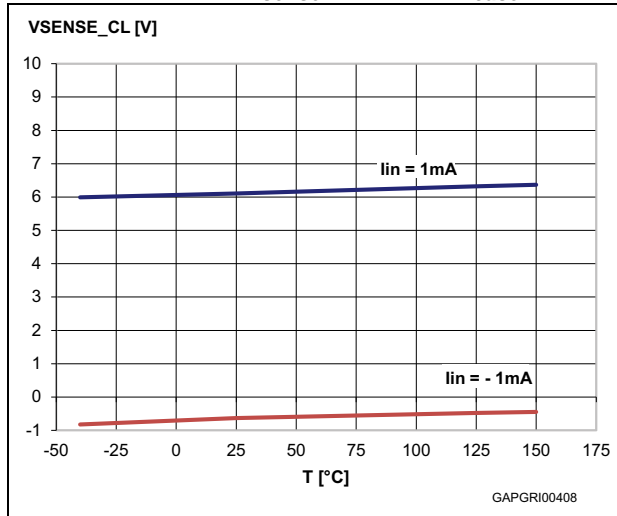
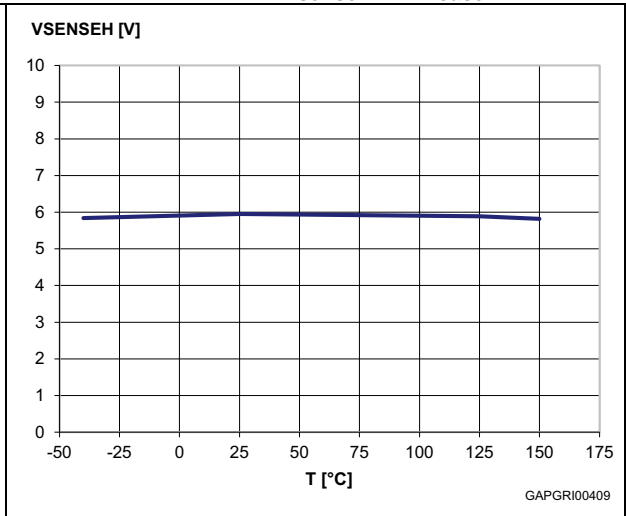

Figure 34. V_{senseh} vs. T_{case}



3 Protections

3.1 Power limitation

The basic working principle of this protection consists of an indirect measurement of the junction temperature swing ΔT_j through the direct measurement of the spatial temperature gradient on the device surface in order to automatically shut off the output MOSFET as soon as ΔT_j exceeds the safety level of ΔT_{j_SD} . According to the voltage level on the FaultRST pin, the output MOSFET switches on and cycles with a thermal hysteresis according to the maximum instantaneous power which can be handled (FaultRST = Low) or remains off (FaultRST = High). The protection prevents fast thermal transient effects and, consequently, reduces thermo-mechanical fatigue.

3.2 Thermal shutdown

In case the junction temperature of the device exceeds the maximum allowed threshold (typically 175°C), it automatically switches off and the diagnostic indication is triggered. According to the voltage level on the FaultRST pin, the device switches on again as soon as its junction temperature drops to T_R (see [Table 8](#), FaultRST = Low) or remains off (FaultRST = High).

3.3 Current limitation

The device is equipped with an output current limiter in order to protect the silicon as well as the other components of the system (e.g. bonding wires, wiring harness, connectors, loads, etc.) from excessive current flow. Consequently, in case of short circuit, overload or during load power-up, the output current is clamped to a safety level, I_{LIMH} , by operating the output power MOSFET in the active region.

3.4 Negative voltage clamp

In case the device drives inductive load, the output voltage reaches negative value during turn off. A negative voltage clamp structure limits the maximum negative voltage to a certain value, V_{DEMAG} (see [Table 8](#)), allowing the inductor energy to be dissipated without damaging the device.

4 Application information

Figure 35. Application diagram

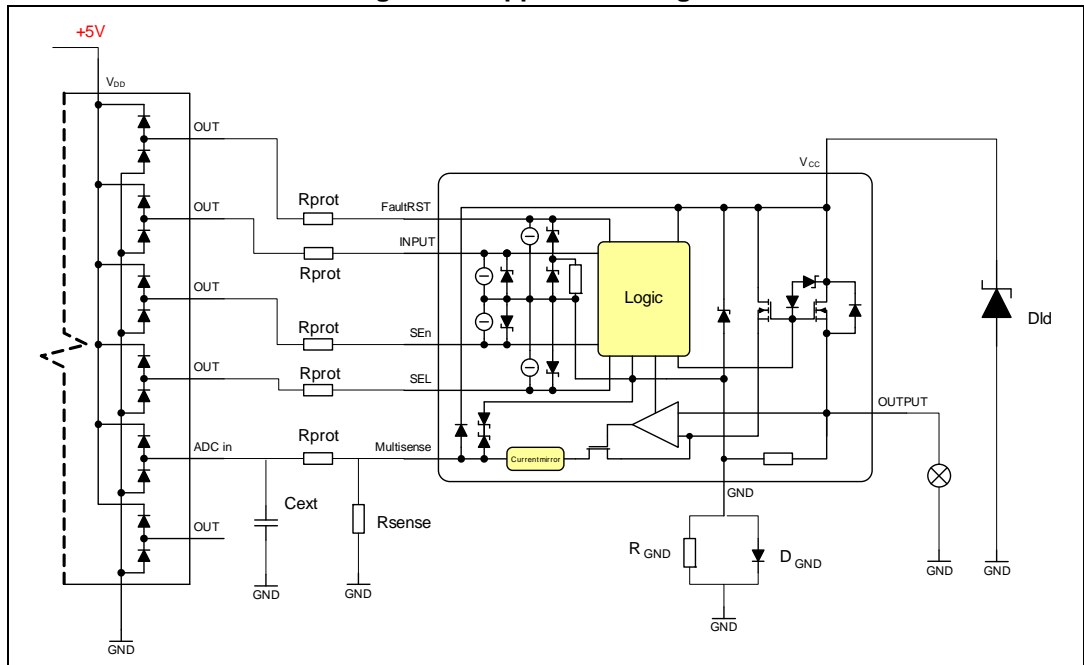

4.1 GND protection network against reverse battery

Figure 36. Simplified internal structure

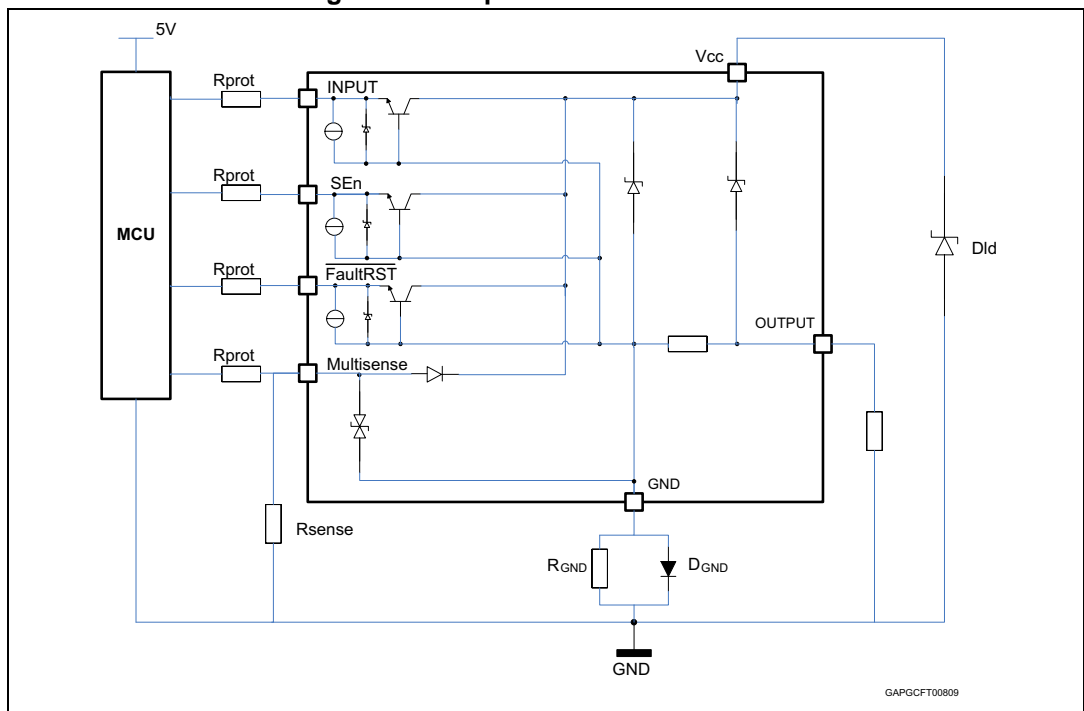

4.1.1 Diode (D_{GND}) in the ground line

A resistor (typ. $R_{GND} = 4.7\text{ k}\Omega$) should be inserted in parallel to D_{GND} if the device drives an inductive load.

This small signal diode can be safely shared amongst several different HSDs. Also in this case, the presence of the ground network produces a shift ($\approx 600\text{ mV}$) in the input threshold and in the status output values if the microprocessor ground is not common to the device ground. This shift does not vary if more than one HSD shares the same diode/resistor network.

4.2 Immunity against transient electrical disturbances

The immunity of the device against transient electrical emissions, conducted along the supply lines and injected into the V_{CC} pin, is tested in accordance with ISO7637-2:2011 (E) and ISO 16750-2:2010.

The related function performance status classification is shown in [Table 12](#).

Test pulses are applied directly to DUT (Device Under Test) both in ON and OFF-state and in accordance to ISO 7637-2:2011(E), chapter 4. The DUT is intended as the present device only, without components and accessed through V_{CC} and GND terminals.

Status II is defined in ISO 7637-1 Function Performance Status Classification (FPSC) as follows: "The function does not perform as designed during the test but returns automatically to normal operation after the test".

Table 12. ISO 7637-2 - electrical transient conduction along supply line

Test Pulse 2011(E)	Test pulse severity level with Status II functional performance status		Minimum number of pulses or test time	Burst cycle / pulse repetition time		Pulse duration and pulse generator internal impedance
	Level	$U_S^{(1)}$		min	max	
1	III	-112V	500 pulses	0,5 s		2ms, 10 Ω
2a	III	+55V	500 pulses	0,2 s	5 s	50 μ s, 2 Ω
3a	IV	-220V	1h	90 ms	100 ms	0.1 μ s, 50 Ω
3b	IV	+150V	1h	90 ms	100 ms	0.1 μ s, 50 Ω
4 ⁽²⁾	IV	-7V	1 pulse			100ms, 0.01 Ω
Load dump according to ISO 16750-2:2010						
Test B ⁽³⁾		40V	5 pulse	1 min		400ms, 2 Ω

1. U_S is the peak amplitude as defined for each test pulse in ISO 7637-2:2011(E), chapter 5.6.
2. Test pulse from ISO 7637-2:2004(E).
3. With 40 V external suppressor referred to ground ($-40^\circ\text{C} < T_j < 150^\circ\text{C}$).

4.3 MCU I/Os protection

If a ground protection network is used and negative transients are present on the V_{CC} line, the control pins will be pulled negative. ST suggests to insert a resistor (R_{prot}) in line both to prevent the microcontroller I/O pins to latch-up and to protect the HSD inputs.

The value of these resistors is a compromise between the leakage current of microcontroller and the current required by the HSD I/Os (Input levels compatibility) with the latch-up limit of microcontroller I/Os.

Equation 1

$$V_{CCpeak}/I_{latchup} \leq R_{prot} \leq (V_{OH\mu C} - V_{IH} - V_{GND}) / I_{IHmax}$$

Calculation example:

For $V_{CCpeak} = -150\text{ V}$; $I_{latchup} \geq 20\text{ mA}$; $V_{OH\mu C} \geq 4.5\text{ V}$

$$7.5\text{ k}\Omega \leq R_{prot} \leq 140\text{ k}\Omega.$$

Recommended values: $R_{prot} = 15\text{ k}\Omega$

4.4 Multisense - analog current sense

Diagnostic information on device and load status are provided by an analog output pin (Multisense) delivering the following signals:

- Current monitor: current mirror of channel output current
- V_{CC} monitor: voltage proportional to V_{CC}
- T_{CASE} : voltage proportional to chip temperature

Those signals are routed through an analog multiplexer which is configured and controlled by means of SELx and SEN pins, according to the address map in [Table 11](#).

Figure 37. Multisense and diagnostic – block diagram

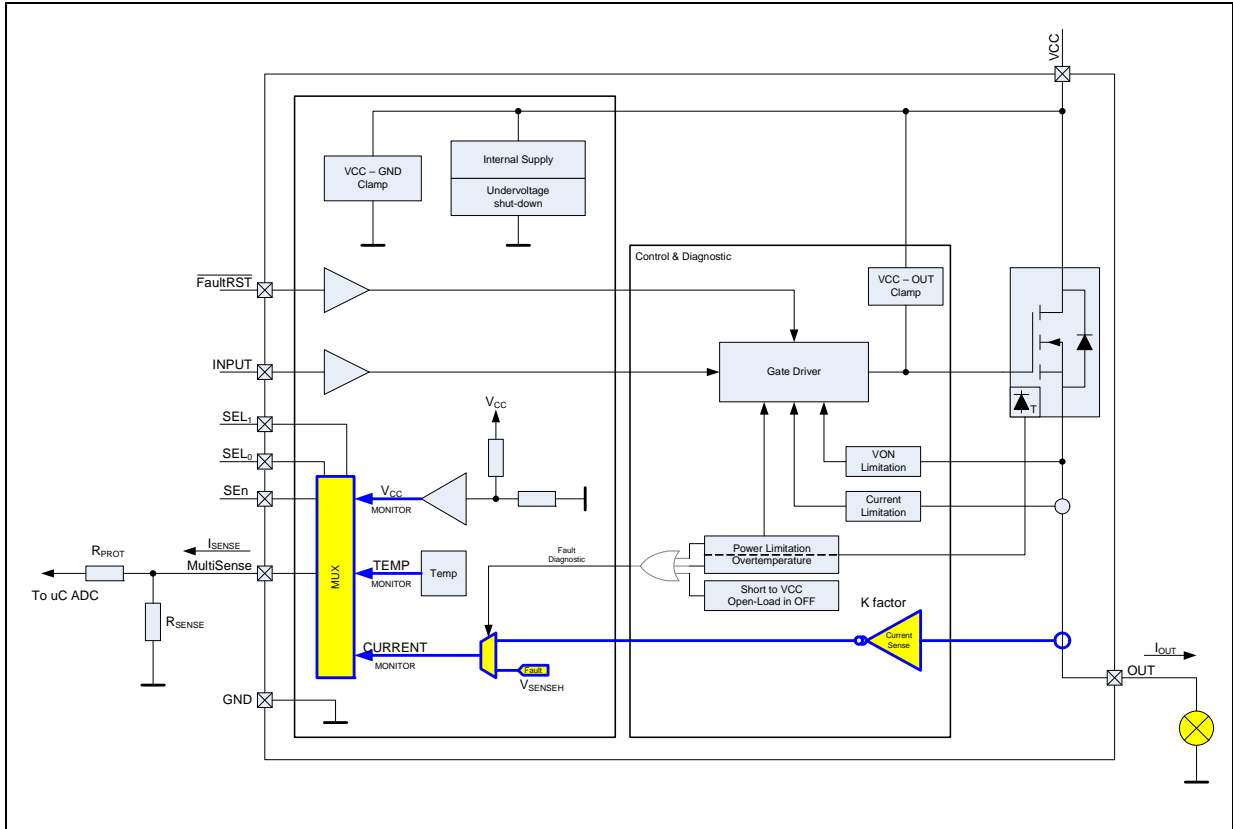

4.4.1 Principle of Multisense signal generation

Figure 38. Multisense block diagram

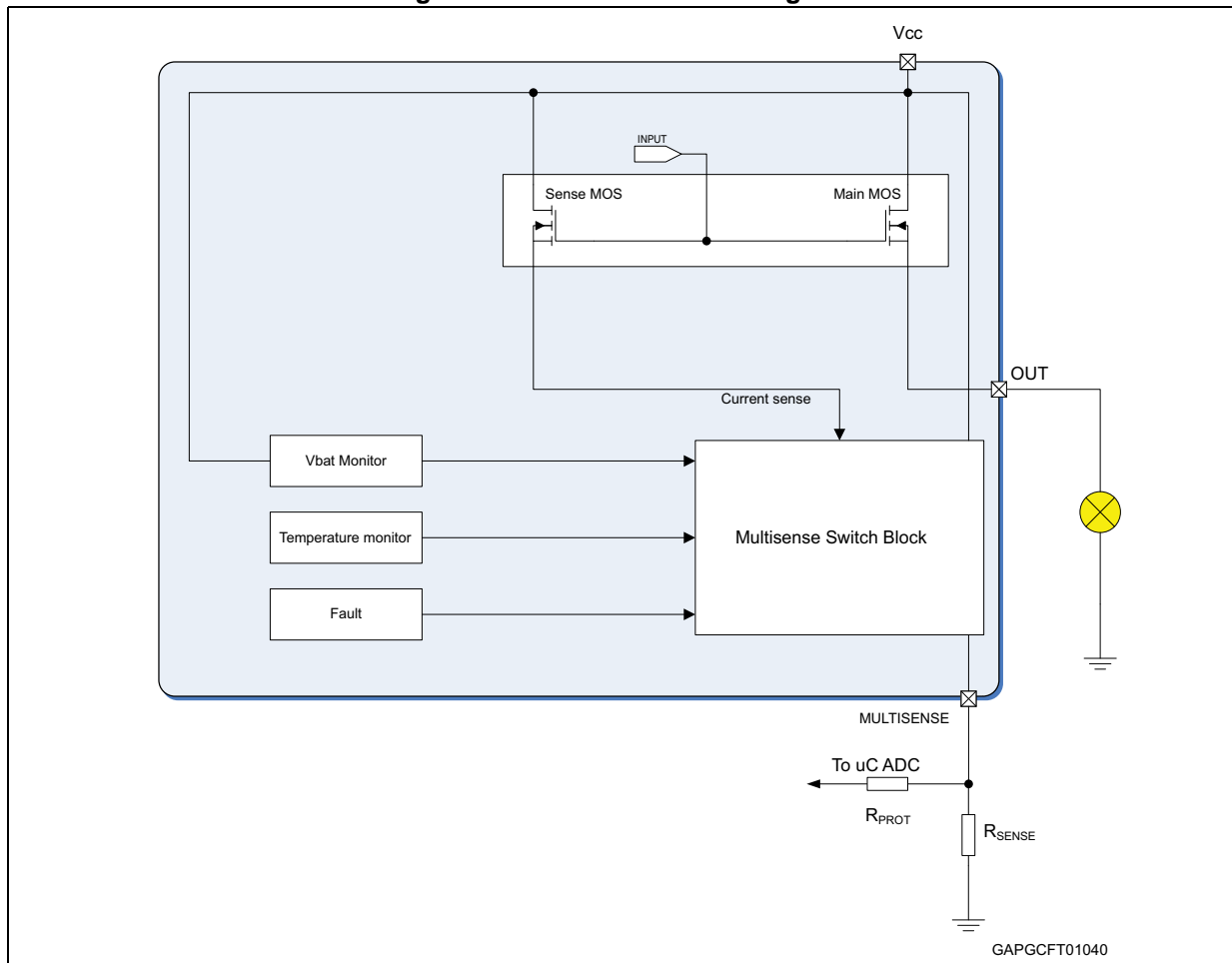

Current monitor

When current mode is selected in the Multisense, this output is capable to provide:

- **Current mirror proportional to the load current in normal operation**, delivering current proportional to the load according to known ratio named **K**
- **Diagnostics flag in fault conditions** delivering fixed voltage V_{SENSEH}

The current delivered by the current sense circuit, I_{SENSE} , can be easily converted to a voltage V_{SENSE} by using an external sense resistor, R_{SENSE} , allowing continuous load monitoring and abnormal condition detection.

Normal operation (channel ON, no fault, SEn active)

While device is operating in normal conditions (no fault intervention), V_{SENSE} calculation can be done using simple equations

Current provided by Multisense output: $I_{SENSE} = I_{OUT}/K$

Voltage on R_{SENSE} : $V_{SENSE} = R_{SENSE} \cdot I_{SENSE} = R_{SENSE} \cdot I_{OUT}/K$

Where :

- V_{SENSE} is voltage measurable on R_{SENSE} resistor
- I_{SENSE} is current provided from Multisense pin in current output mode
- I_{OUT} is current flowing through output
- K factor represent the ratio between PowerMOS cells and SenseMOS cells; its spread includes geometric factor spread, current sense amplifier offset and process parameters spread of overall circuitry specifying ratio between I_{OUT} and I_{SENSE} .

Failure flag indication

In case of power limitation/overtemperature, the fault is indicated by the Multisense pin which is switched to a “current limited” voltage source, V_{SENSEH} (see [Table 9](#)).

In any case, the current sourced by the Multisense in this condition is limited to I_{SENSEH} (see [Table 9](#)).

The typical behavior in case of overload or hard short circuit is shown in [Figure 10](#), [Figure 11](#) and [Figure 12](#).

Figure 39. Analogue HSD – open-load detection in off-state

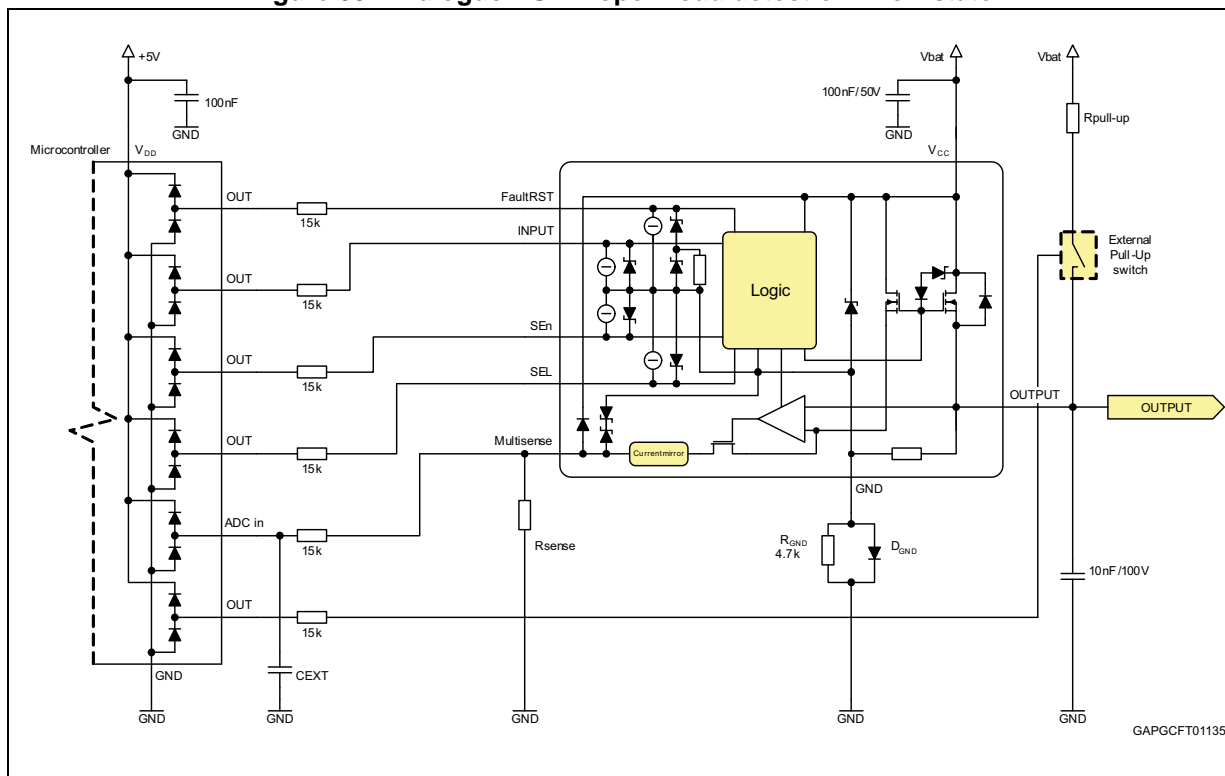

Figure 40. Open-load / short to V_{CC} condition

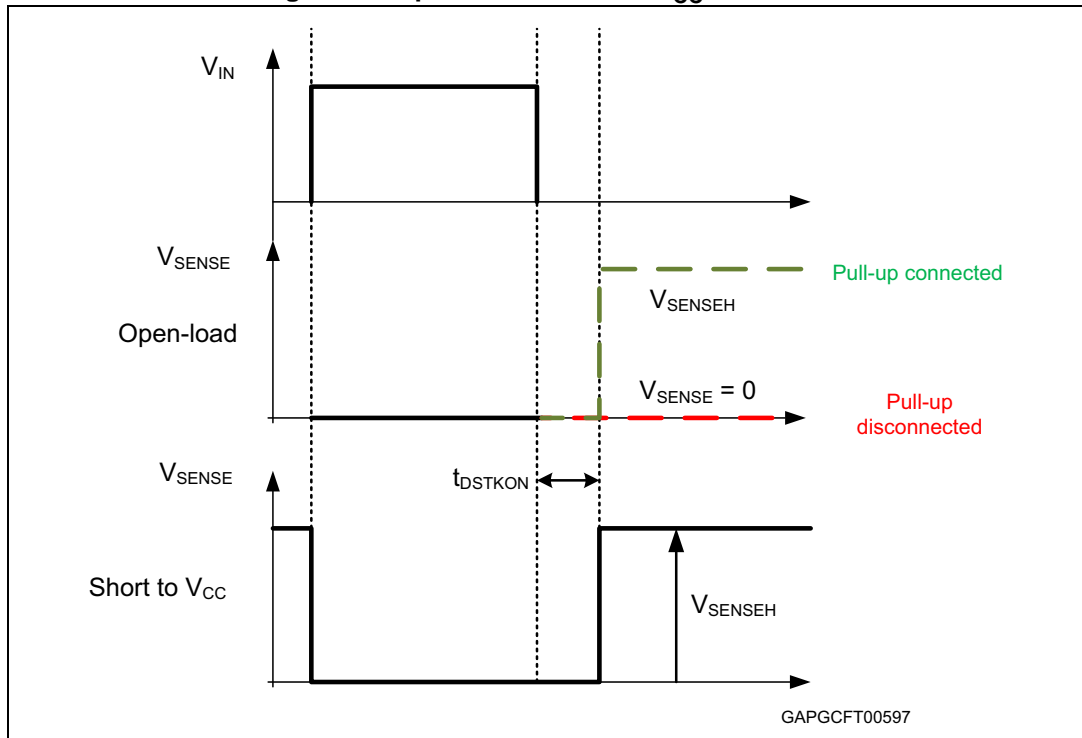

Table 13. MultiSense pin levels in off-state

Condition	Output	MultiSense	SEn
Open-load	$V_{OUT} > V_{OL}$	Hi-Z	L
		V_{SENSEH}	H
Open-load	$V_{OUT} < V_{OL}$	Hi-Z	L
		0	H
Short to V_{CC}	$V_{OUT} > V_{OL}$	Hi-Z	L
		V_{SENSEH}	H
Nominal	$V_{OUT} < V_{OL}$	Hi-Z	L
		0	H

4.4.2 T_{CASE} and V_{CC} monitor

In this case, MultiSense output operates in voltage mode and output level is referred to device GND. Care must be taken in case a GND network protection is used, because of a voltage shift is generated between device GND and the microcontroller input GND reference.

Figure 41 shows link between $V_{MEASURED}$ and real V_{SENSE} signal.

Figure 41. GND voltage shift

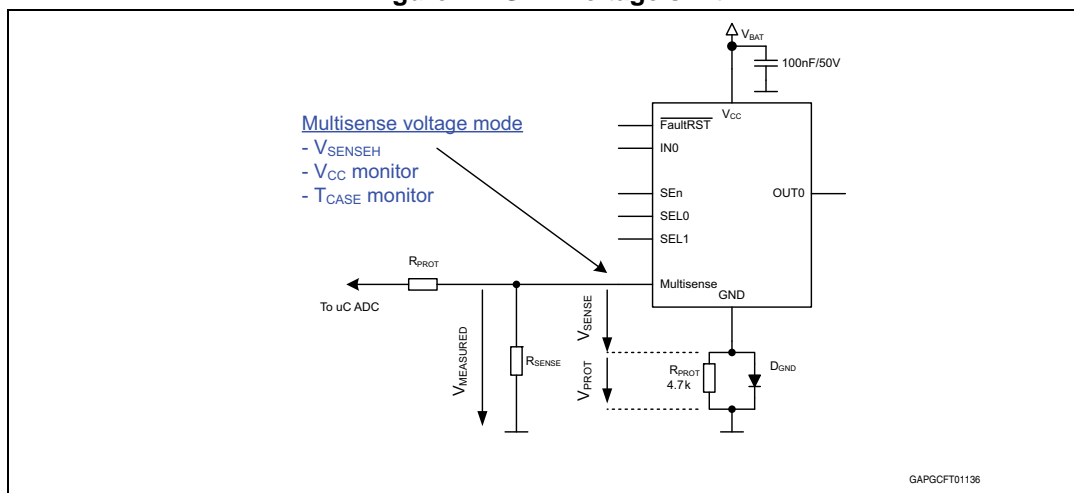

V_{CC} monitor

Battery monitoring channel provides $V_{SENSE} = V_{CC} / 4$.

Case temperature monitor

Case temperature monitor is capable to provide information about actual device temperature. Since diode is used for temperature sensing, following equation describe link between temperature and output V_{SENSE} level:

$$V_{SENSE_TC}(T) = V_{SENSE_TC}(T_0) + dV_{SENSE_TC} / dT * (T - T_0)$$

where $dV_{SENSE_TC} / dT \sim$ typically -5.5 mV/K (for temperature range $(-40^{\circ}\text{C}$ to $+150^{\circ}\text{C}$).

4.4.3 Short to V_{CC} and OFF-state open-load detection

Short to V_{CC}

A short circuit between V_{CC} and output is indicated by the relevant current sense pin set to V_{SENSEH} during the device off-state. Small or no current is delivered by the current sense during the on-state depending on the nature of the short circuit.

OFF-state open-load with external circuitry

Detection of an open-load in off mode requires an external pull-up resistor R_{PU} connecting the output to a positive supply voltage V_{PU} .

It is preferable V_{PU} to be switched off during the module standby mode in order to avoid the overall standby current consumption to increase in normal conditions, i.e. when load is connected.

R_{PU} must be selected in order to ensure $V_{OUT} > V_{OLmax}$ in accordance with to following equation:

Equation 2

$$R_{PU} < \frac{V_{PU} - 4}{I_{L(off2)min} @ 4V}$$

4.5 Maximum demagnetization energy ($V_{CC} = 16\text{ V}$)

Figure 42. Maximum turn off current versus inductance

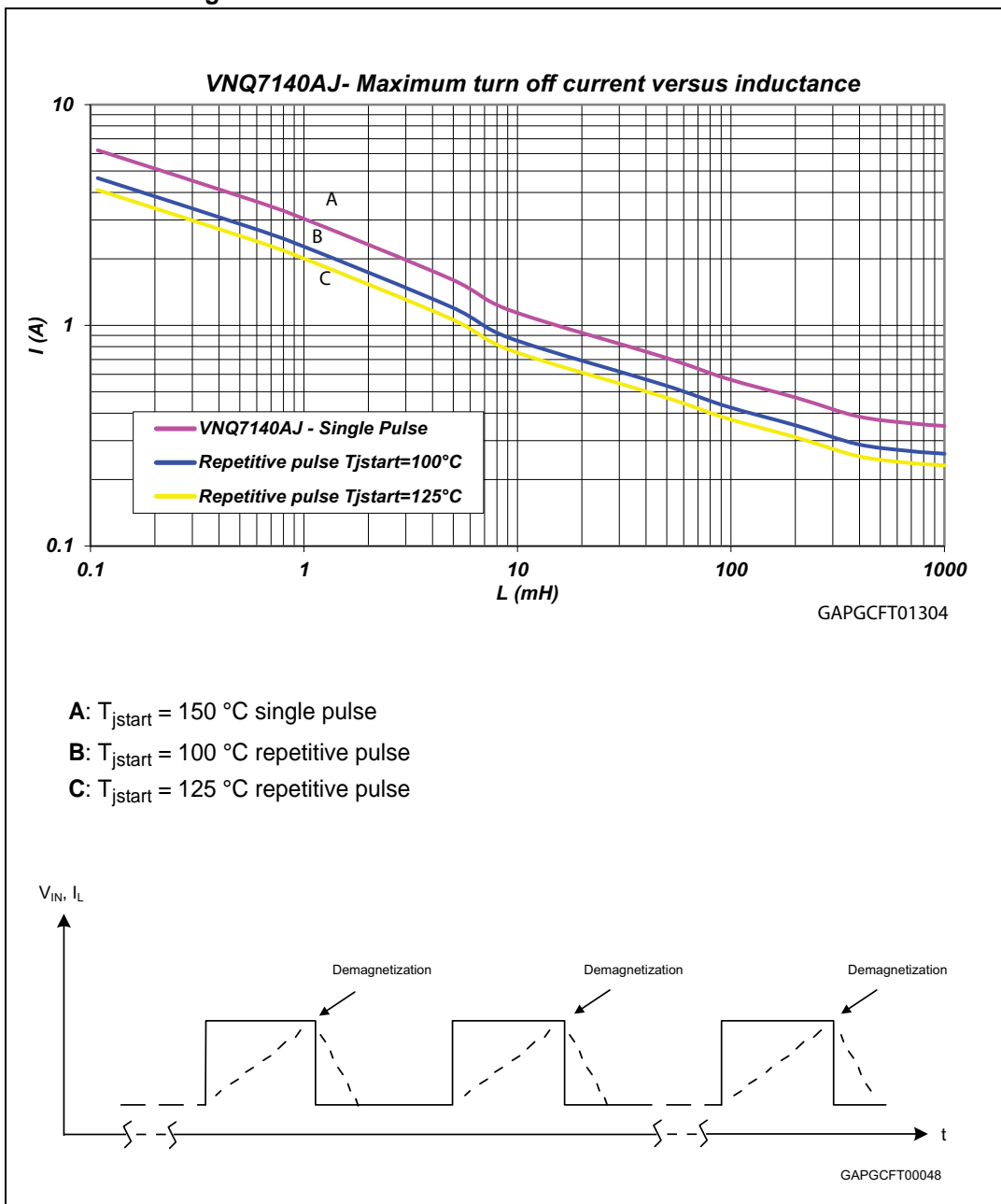

- A: $T_{jstart} = 150\text{ }^{\circ}\text{C}$ single pulse
- B: $T_{jstart} = 100\text{ }^{\circ}\text{C}$ repetitive pulse
- C: $T_{jstart} = 125\text{ }^{\circ}\text{C}$ repetitive pulse

1. Values are generated with $R_L = 0\ \Omega$.
 In case of repetitive pulses, T_{jstart} (at the beginning of each demagnetization) of every pulse must not exceed the temperature specified above for curves A and B.

5 Package and PCB thermal data

5.1 PowerSSO-16 thermal data

Figure 43. PowerSSO-16 on two-layers PCB (2s0p to JEDEC JESD 51-5)

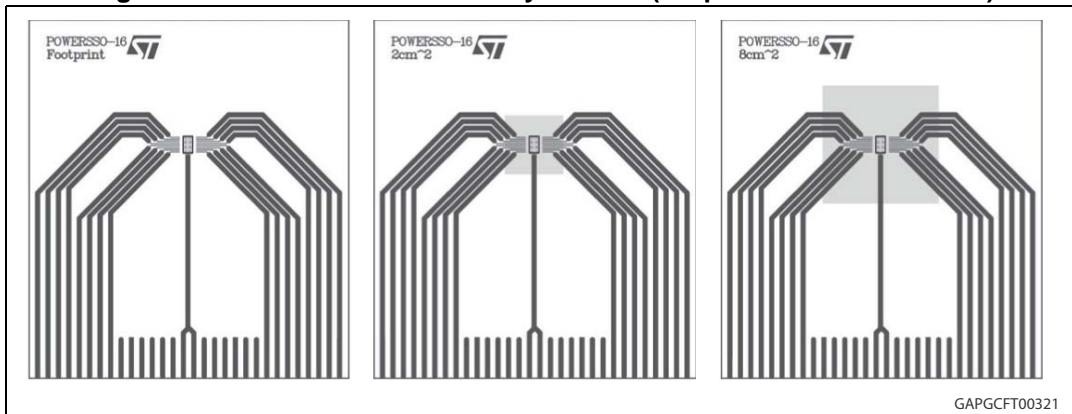

Figure 44. PowerSSO-16 on four-layers PCB (2s2p to JEDEC JESD 51-7)

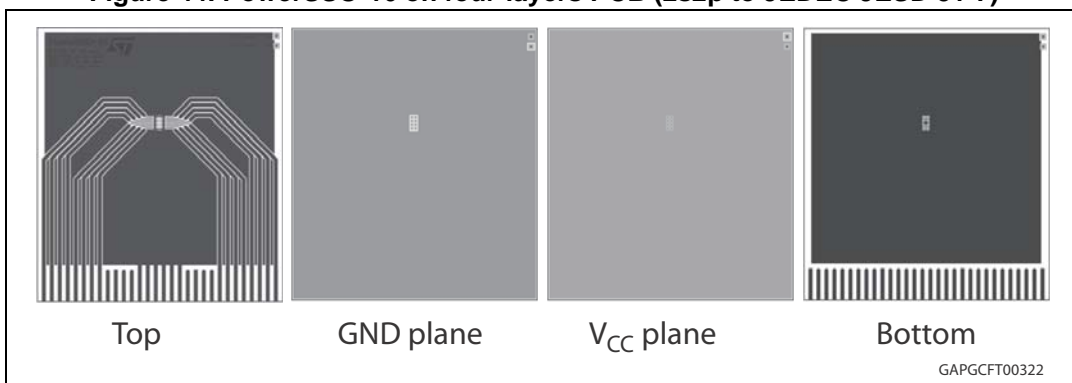

Table 14. PCB properties

Dimension	Value
Board finish thickness	1.6 mm +/- 10%
Board dimension	77 mm x 86 mm
Board Material	FR4
Copper thickness (top and bottom layers)	0.070 mm
Copper thickness (inner layers)	0.035 mm
Thermal vias separation	1.2 mm
Thermal via diameter	0.3 mm +/- 0.08 mm
Copper thickness on vias	0.025 mm
Footprint dimension (top layer)	2.2 mm x 3.9 mm
Heatsink copper area dimension (bottom layer)	Footprint, 2 cm ² or 8 cm ²

Figure 45. PowerSSO-16 $R_{thj-amb}$ vs PCB copper area in open box free air condition

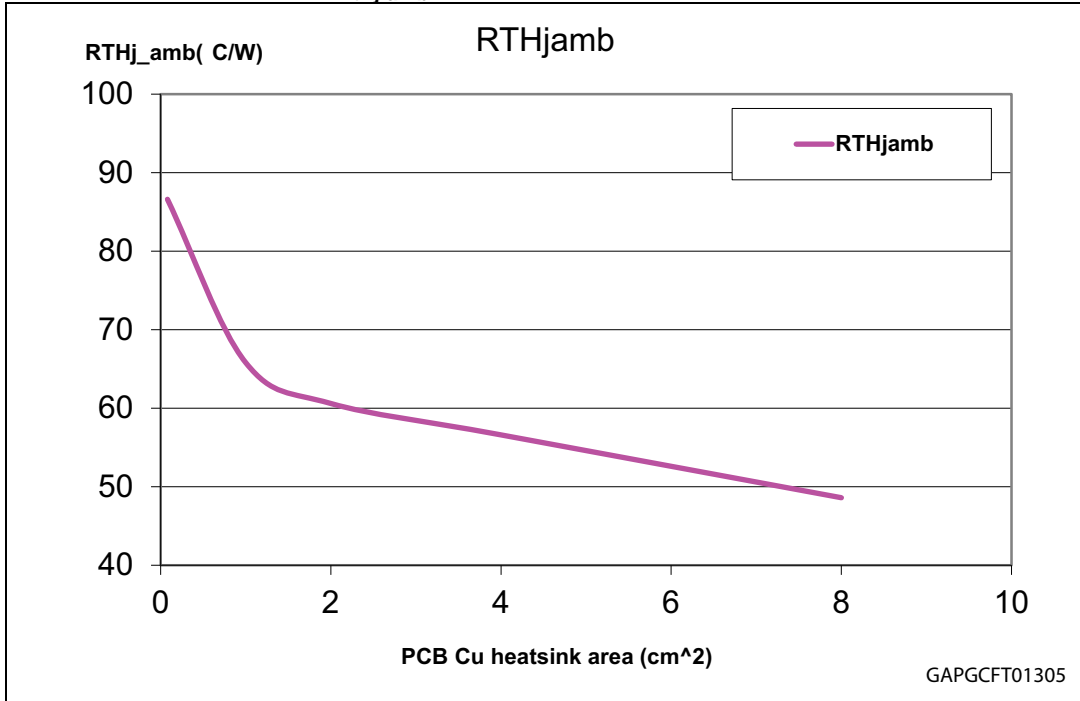
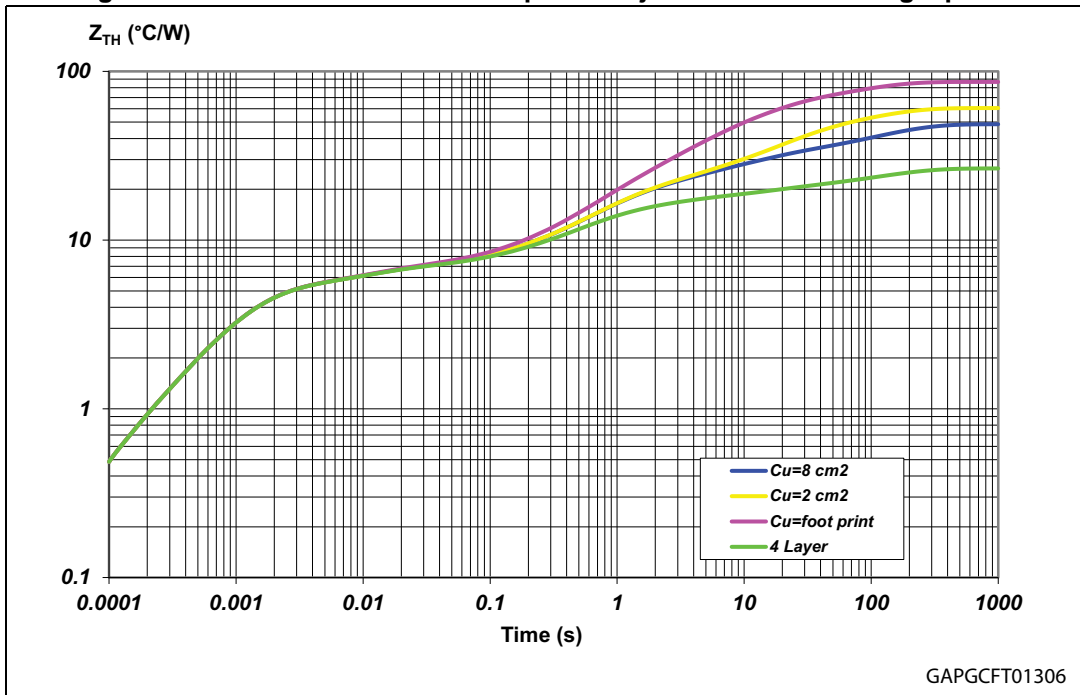

Figure 46. PowerSSO-16 thermal impedance junction ambient single pulse



Equation 3: pulse calculation formula

$$Z_{TH\delta} = R_{TH} \cdot \delta + Z_{THtp}(1 - \delta)$$

where $\delta = t_p/T$

Figure 47. Thermal fitting model for PowerSSO-16

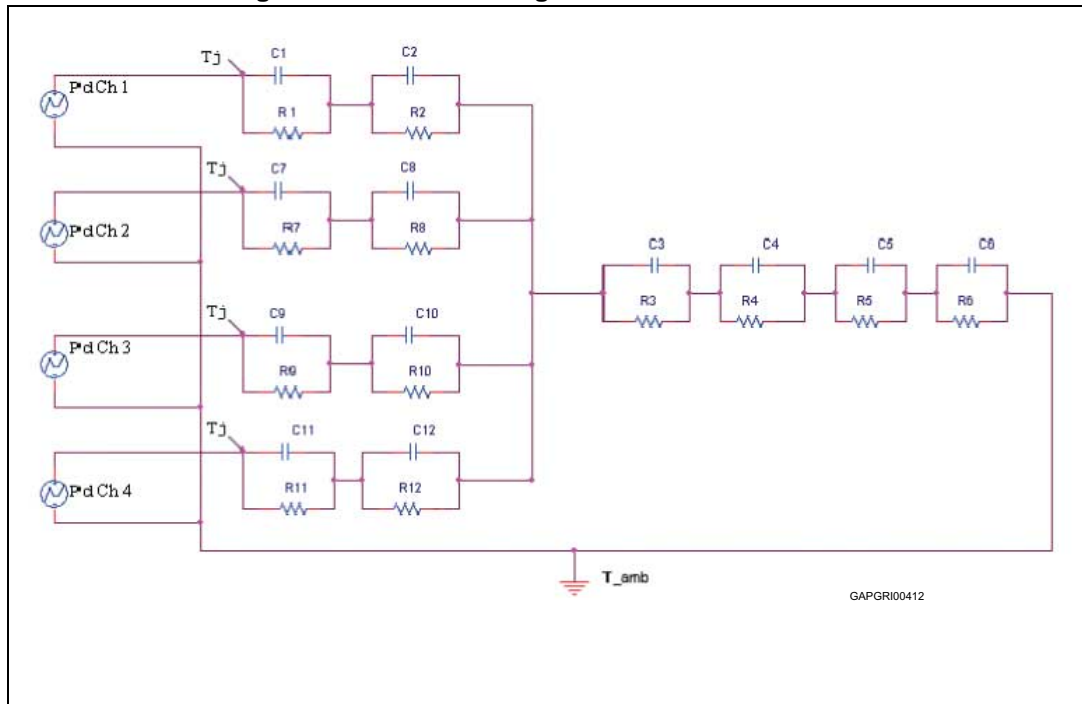

1. The fitting model is a simplified thermal tool and is valid for transient evolutions where the embedded protections (power limitation or thermal cycling during thermal shutdown) are not triggered.

Table 15. Thermal parameters

Area/island (cm ²)	Footprint	2	8	4L
R1 = R7 = R9 = R11 (°C/W)	4.8			
R2 = R8 = R10 = R12 (°C/W)	1.8			
R3 (°C/W)	8	8	8	5
R4 (°C/W)	16	6	6	4
R5 (°C/W)	30	20	10	3
R6 (°C/W)	26	20	18	7
C1 = C7 = C9 = C11 (W.s/°C)	0.0002			
C2 = C8 = C10 = C12 (W.s/°C)	0.005			
C3 (W.s/°C)	0.08			
C4 (W.s/°C)	0.2	0.3	0.3	0.4
C5 (W.s/°C)	0.4	1	1	4
C6 (W.s/°C)	3	5	7	18

6 Package information

6.1 ECOPACK®

In order to meet environmental requirements, ST offers these devices in different grades of ECOPACK® packages, depending on their level of environmental compliance. ECOPACK® specifications, grade definitions and product status are available at: www.st.com.

ECOPACK® is an ST trademark.

6.2 PowerSSO-16 package information

Figure 48. PowerSSO-16 package dimensions

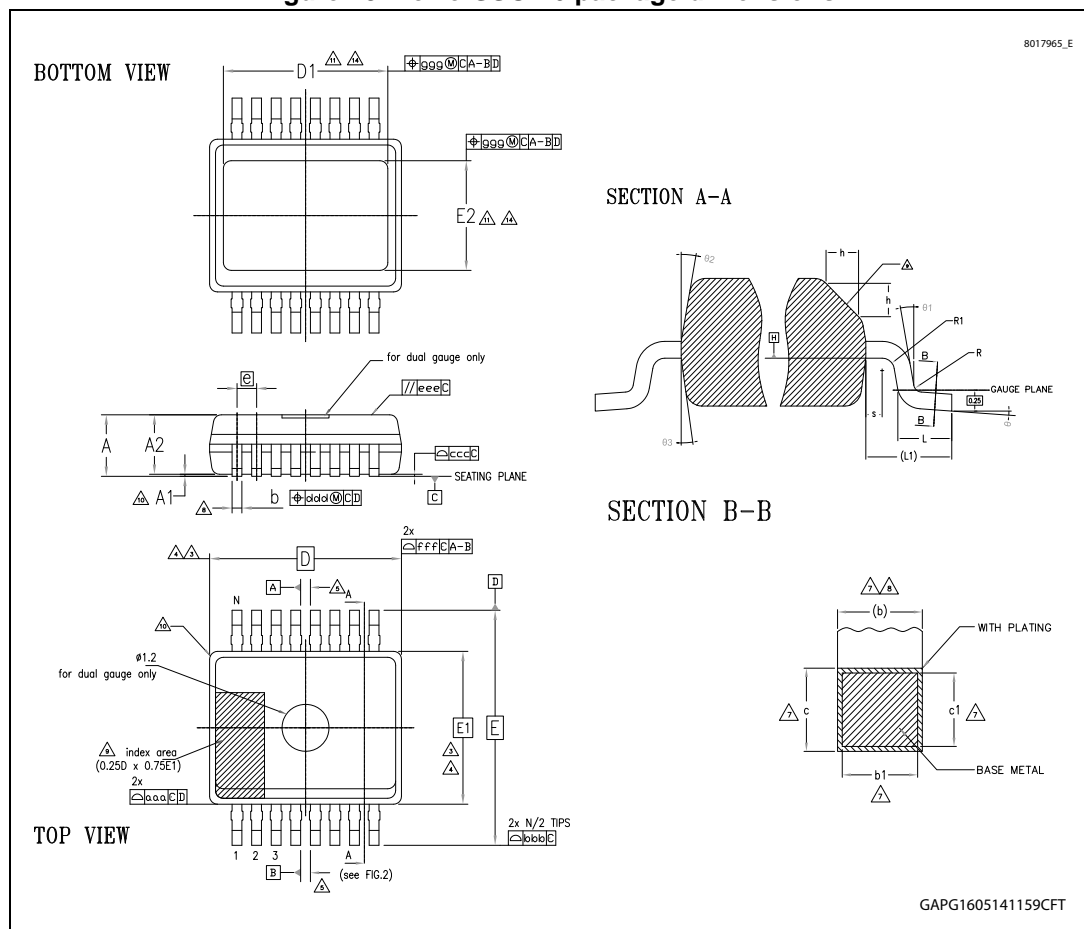

Table 16. PowerSSO-16 mechanical data

Symbol	Millimeters		
	Min.	Typ.	Max.
Θ	0°		8°
$\Theta 1$	0°		
$\Theta 2$	5°		15°
$\Theta 3$	5°		15°
A			1.70
A1	0.00		0.10
A2	1.10		1.65
b	0.20		0.30
b1	0.20	0.25	0.30
c	0.19		0.25
c1	0.19	0.20	0.23
D	4.9		
D1	1.90		2.50
e	0.50		
E	6.00		
E1	3.90		
E2	3.60		4.20
h	0.25		0.50
L	0.40	0.60	0.85
L1	1.00		
N	16		
R	0.7		
R1	0.7		
S	0.20		

7 Order codes

Table 17. Device summary

Package	Order codes	
	Tube	Tape and reel
PowerSSO-16	VNQ7140AJ-E	VNQ7140AJTR-E

8 Revision history

Table 18. Document revision history

Date	Revision	Changes
25-Oct-2011	1	Initial release.
04-Jul-2012	2	<p>Updated Table 1: Pin functions Updated Figure 2: Configuration diagram (top view) Table 3: Absolute maximum ratings: – V_{CCPK}, V_{CCJS}: added rows – I_{SENSE}, V_{ESD}: updated values and parameters – -V_{SENSE}: removed row Updated Table 4: Thermal data Table 5: Power section: – V_{USDRReset}, I_{GND(ON)}: added row – V_{clamp}, t_{D_STBY}, I_{S(ON)}: updated value Updated Table 6: Switching (VCC = 13 V; -40°C < T_j < 150°C, unless otherwise specified) Table 7: Logic Inputs (7 V < V_{CC} < 28 V; -40°C < T_j < 150°C): – V_{ICL}, V_{FRCL}, V_{SELCL}, V_{SEnCL}: updated value Table 8: Protections (7 V < V_{CC} < 18 V; -40°C < T_j < 150°C): – t_{LATCH_RST}: updated values – V_{DEMAG}: updated test conditions and value – V_{ON}: updated test conditions Updated Table 9: MultiSense (7 V < V_{CC} < 18 V; -40°C < T_j < 150°C) Updated Figure 7: MultiSense timings (current sense mode) and Figure 8: Multisense timings (chip temperature and VCC sense mode) Added Figure 9: T_{DSKON} Updated Section 2.4: Waveforms Added Chapter 3: Protections and Chapter 4: Application information</p>
18-Oct-2012	3	<p>Table 5: Power section: – I_{GND(ON)}: updated values Updated Table 6: Switching (VCC = 13 V; -40°C < T_j < 150°C, unless otherwise specified) Table 9: MultiSense (7 V < V_{CC} < 18 V; -40°C < T_j < 150°C): – V_{SENSE_CL}, K_{OL}, K_{LED}, K₀, dK₀/K₀, K₁, dK₁/K₁, K₂, dK₂/K₂, K₃, dK₃/K₃, V_{SENSEH}: updated values – V_{SENSE_TC}: updated parameter</p>



Table 18. Document revision history (continued)

Date	Revision	Changes
21-Jun-2013	4	<p>Updated <i>Table</i> :</p> <p><i>Table 3: Absolute maximum ratings:</i></p> <ul style="list-style-type: none"> – V_{CCPK}: updated parameter – I_{OUT}, I_{SENSE}: updated value – E_{MAX}: updated parameter and value <p><i>Table 5: Power section:</i></p> <ul style="list-style-type: none"> – V_F: updated test conditions <p><i>Table 8: Protections ($7\text{ V} < V_{CC} < 18\text{ V}$; $-40^\circ\text{C} < T_j < 150^\circ\text{C}$):</i></p> <ul style="list-style-type: none"> – T_{HYST}: added note <p><i>Table 9: MultiSense ($7\text{ V} < V_{CC} < 18\text{ V}$; $-40^\circ\text{C} < T_j < 150^\circ\text{C}$):</i></p> <ul style="list-style-type: none"> – dK_{cal}/K_{cal}: added row – K_{OL}, K_{LED}, K_0, K_1, K_3: updated values – I_{SENSE_SAT}, I_{OUT_SAT}: added note – V_{SENSE_TC}: updated test conditions and values – V_{SENSE_VCC}: updated test conditions <p><i>Table 11: MultiSense multiplexer addressing</i></p> <ul style="list-style-type: none"> – updated negative output values <p>Removed following tables:</p> <p><i>Table: Electrical transient requirements (part 1/3)</i></p> <p><i>Table: Electrical transient requirements (part 2/3)</i></p> <p><i>Table: Electrical transient requirements (part 3/3)</i></p> <p>Updated <i>Section 3.1: Power limitation</i>, <i>Section 3.2: Thermal shutdown</i>, <i>Section 3.4: Negative voltage clamp</i> and <i>Section 4.1.1: Diode (DGND) in the ground line</i></p> <p>Removed <i>Section: Load dump protection</i></p> <p>Added <i>Section 4.2: Immunity against transient electrical disturbances</i></p> <p>Updated <i>Section 4.4.1: Principle of Multisense signal generation</i></p> <p>Updated <i>Figure 39: Analogue HSD – open-load detection in off-state</i></p> <p>Updated <i>Table 13: MultiSense pin levels in off-state</i></p> <p>Updated <i>Figure 41: GND voltage shift</i></p> <p>Added <i>Section 4.5: Maximum demagnetization energy ($V_{CC} = 16\text{ V}$)</i></p> <p>Updated <i>Chapter 5: Package and PCB thermal data</i></p> <p>Updated <i>Section 6.2: PowerSSO-16 package information</i></p>
18-Jul-2013	5	<p>Updated <i>Table 4: Thermal data</i></p> <p>Updated <i>Table 6: Switching ($V_{CC} = 13\text{ V}$; $-40^\circ\text{C} < T_j < 150^\circ\text{C}$, unless otherwise specified)</i></p> <p>Added <i>Section 2.5: Electrical characteristics curves</i></p>
20-Sep-2013	6	Updated disclaimer.
09-Jun-2014	7	Updated <i>Section 6.2: PowerSSO-16 package information</i>

Please Read Carefully:

Information in this document is provided solely in connection with ST products. STMicroelectronics NV and its subsidiaries ("ST") reserve the right to make changes, corrections, modifications or improvements, to this document, and the products and services described herein at any time, without notice.

All ST products are sold pursuant to ST's terms and conditions of sale.

Purchasers are solely responsible for the choice, selection and use of the ST products and services described herein, and ST assumes no liability whatsoever relating to the choice, selection or use of the ST products and services described herein.

No license, express or implied, by estoppel or otherwise, to any intellectual property rights is granted under this document. If any part of this document refers to any third party products or services it shall not be deemed a license grant by ST for the use of such third party products or services, or any intellectual property contained therein or considered as a warranty covering the use in any manner whatsoever of such third party products or services or any intellectual property contained therein.

UNLESS OTHERWISE SET FORTH IN ST'S TERMS AND CONDITIONS OF SALE ST DISCLAIMS ANY EXPRESS OR IMPLIED WARRANTY WITH RESPECT TO THE USE AND/OR SALE OF ST PRODUCTS INCLUDING WITHOUT LIMITATION IMPLIED WARRANTIES OF MERCHANTABILITY, FITNESS FOR A PARTICULAR PURPOSE (AND THEIR EQUIVALENTS UNDER THE LAWS OF ANY JURISDICTION), OR INFRINGEMENT OF ANY PATENT, COPYRIGHT OR OTHER INTELLECTUAL PROPERTY RIGHT.

ST PRODUCTS ARE NOT DESIGNED OR AUTHORIZED FOR USE IN: (A) SAFETY CRITICAL APPLICATIONS SUCH AS LIFE SUPPORTING, ACTIVE IMPLANTED DEVICES OR SYSTEMS WITH PRODUCT FUNCTIONAL SAFETY REQUIREMENTS; (B) AERONAUTIC APPLICATIONS; (C) AUTOMOTIVE APPLICATIONS OR ENVIRONMENTS, AND/OR (D) AEROSPACE APPLICATIONS OR ENVIRONMENTS. WHERE ST PRODUCTS ARE NOT DESIGNED FOR SUCH USE, THE PURCHASER SHALL USE PRODUCTS AT PURCHASER'S SOLE RISK, EVEN IF ST HAS BEEN INFORMED IN WRITING OF SUCH USAGE, UNLESS A PRODUCT IS EXPRESSLY DESIGNATED BY ST AS BEING INTENDED FOR "AUTOMOTIVE, AUTOMOTIVE SAFETY OR MEDICAL" INDUSTRY DOMAINS ACCORDING TO ST PRODUCT DESIGN SPECIFICATIONS. PRODUCTS FORMALLY ESCC, QML OR JAN QUALIFIED ARE DEEMED SUITABLE FOR USE IN AEROSPACE BY THE CORRESPONDING GOVERNMENTAL AGENCY.

Resale of ST products with provisions different from the statements and/or technical features set forth in this document shall immediately void any warranty granted by ST for the ST product or service described herein and shall not create or extend in any manner whatsoever, any liability of ST.

ST and the ST logo are trademarks or registered trademarks of ST in various countries.

Information in this document supersedes and replaces all information previously supplied.

The ST logo is a registered trademark of STMicroelectronics. All other names are the property of their respective owners.

© 2014 STMicroelectronics - All rights reserved

STMicroelectronics group of companies

Australia - Belgium - Brazil - Canada - China - Czech Republic - Finland - France - Germany - Hong Kong - India - Israel - Italy - Japan - Malaysia - Malta - Morocco - Philippines - Singapore - Spain - Sweden - Switzerland - United Kingdom - United States of America

www.st.com