

Features and Benefits

- Low cost
- 12V/24V fans
- High sensitivity Hall Sensor
- Peak current up to 500mA

Application Examples

- Locked rotor protection and auto-restart
- Power-efficient CMOS and power MOSFETs
- Built-in output protection clamping diode
- Integrated tachometer (US90A) or alarm (US91A) signal output
- 2-coil fan driver with FG/RD output in 4-pin VK / VA and 8-pin narrow SOIC packages (all RoHS Compliant)

Ordering Code

Product Code	Temperature Code	Package Code	Option Code	Packing Form Code
US90A	E	DC	AAA-000	RE
US90A	E	DC	AAA-000	RX
US91A	E	DC	AAA-000	RX
US90A	E	VK	AAA-000	BU
US90A	E	VK	AAA-000	RX
US91A	E	VK	AAA-000	BU
US91A	E	VK	AAA-000	RX
US90A	E	VA	AAA-000	BU
US91A	E	VA	AAA-000	BU

Legend:

- Package Code:
 - DC for SOIC150Mil,
 - VK for Plastic Single in Line thickness 1.5 - 1.6mm
 - VA for Plastic Single in Line thickness 1.1 -1.2mm
- Packing Form:
 - RE for Reel (face up, live bug)
 - RX for Reel (face down, dead bug)
 - VKAAA000-RX: Trimmed leads: 5.17mm
 - BU for Bulk

Ordering example: US90A-EDC-AAA-000-RE

1 Functional Diagram

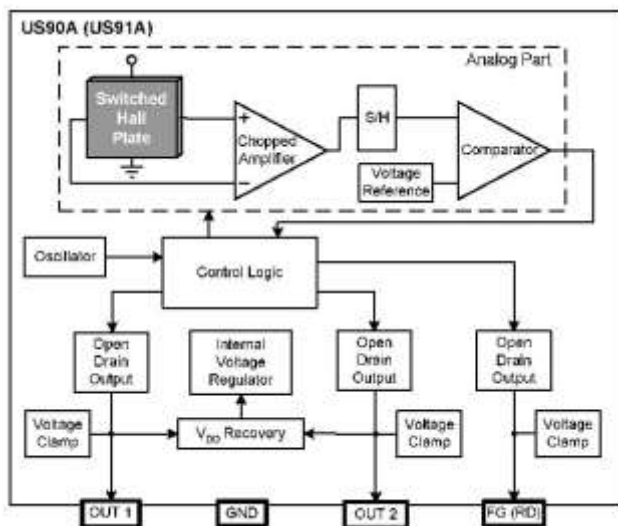

2 General Description

The US90A/91A is a one-chip solution for driving two-coil brushless DC cooling fans.

Based on the advanced Melexis CMOS process, the IC contains a Hall-effect sensor, dynamic offset correction and low side output drivers.

Frequency Generator or Rotation Detection is available. The open-drain output makes the connectivity with any external interface such as hardware monitoring or Super I/O IC easier.

These features are combined with the Melexis patented no-V_{DD} design to fit the IC in small 4-pin VK and VA package. The device is also delivered in DC package for automatic assembly.

3 Glossary of terms

Two-coil fan	A fan with two-coil windings where current alternates from 1 coil to the other depending on the direction of the magnetic field.
MilliTesla (mT), Gauss	Units of magnetic flux density : 1mT = 10 Gauss
V _{DD}	Voltage on the coils common node.
I _{DD}	Current supplying the chip which flows through the coil connected to the switched off output driver.
Peak output current	The current flowing in the coil at start-up, only limited by the coil resistance R _{COIL} and the output driver resistance R _{DSON} .
Continuous output current	The current flowing in the coil when the fan is spinning normally.
Locked rotor	The state when the fan stopped spinning due to mechanical blockage.
FG	Frequency generator or tachometer output
RD	Rotation detection or alarm output
LFPM	Linear Feet Per Minute – Unit of airflow velocity

4 Absolute maximum rating

Parameter	Symbol	Value	Units
Fan Supply Voltage	V _{DD}	30	V
Peak Output Current	I _{OUTP}	500	mA
Continuous Output Current	I _{OUTC}	250	mA
FG / RD Output Current	I _{FG (RD)}	20	mA
Junction Temperature	T _J	-40 to 125	°C
Storage Temperature Range	T _S	-55 to 150	°C
Magnetic Flux Density	B	Unlimited	mT

Exceeding the absolute maximum ratings may cause permanent damage. Exposure to absolute-maximum rated conditions for extended periods may affect device reliability.

5 Pin Definitions and descriptions

Pin Name	Pin number (VK)	Pin number (DC)	Pin number (VA)	Function
FG (RD)	1	1	1	FG (RD) open drain output signal
OUT1	2	2	2	Open Drain Coil Driver 1
OUT2	3	4	4	Open Drain Coil Driver 2
GND	4	3	3	Ground pin
		5, 6, 7, 8		Not Connected

Table 2: Pin definitions and descriptions US90A (US91A)

6 General electrical specifications

DC Operating Parameters $T_A = 25^\circ\text{C}$, $V_{DD} = 24\text{V}$ (unless otherwise specified)

Parameter	Symbol	Test Conditions	Min	Typ	Max	Units
Fan Supply Voltage	V_{DD}	Operating, $R_{COIL} = 50\Omega$	4.7 ⁽¹⁾		30	V
Supply Current	I_{DD}			2	4	mA
Output Saturation Voltage	$V_{DSON_{1,2}}$	$I_{OUT} = 150\text{mA}$		375		mV
Output Saturation Voltage	$V_{DSON_{1,2}}$	$I_{OUT} = 250\text{mA}$		625		mV
Output Clamp Voltage	$V_{OUT_{1,2}}$		60			V
FG / RD Output Low Voltage	V_{OL}	$I_{OL} = 10\text{mA}$		250	500	mV
FG / RD Output Clamp Voltage	V_{CLAMP}		28			V
FG / RD Output Leakage Current	I_{LEAK}	$V_{FG} (V_{RD}) = 18\text{V}$			10	μA
DC Thermal Resistance	R_{THja}	Onesided PCB, zero LFPM		150		$^\circ\text{C}/\text{Watt}$
VK Thermal Resistance	R_{THja}	Onesided PCB, zero LFPM		200		$^\circ\text{C}/\text{Watt}$
VA Thermal Resistance	R_{THja}	Onesided PCB, zero LFPM		170		$^\circ\text{C}/\text{Watt}$

Table 3: General electrical specifications

Note 1: The minimal value of V_{DD} should be determined using the following equation: $V_{DD} = 4.5\text{V} + R_{COIL} * I_{DD}$

7 Magnetic specifications

DC Operating Parameters $T_A = 25^\circ\text{C}$, $V_{DD} = 24\text{V}$ (unless otherwise specified)

Parameter	Symbol	Test Conditions	Min	Typ	Max	Units
Operate point	B_{OP}			3	6	mT
Release point	B_{RP}		6	3		mT
Hysteresis	B_{HYST}		2	6		mT

Table 4: Magnetic specifications

8 Driver output vs. Magnetic Pole

Parameter	Test Conditions	OUT1	OUT2
North pole	$B < B_{rp}$ – all packages	High	Low
South pole	$B > B_{op}$ all packages	Low	High

Table 5: Driver output vs. magnetic pole

Note 3: The magnetic pole is applied facing the branded side of the package

9 Detailed general description

The US90A/91A is a one-chip solution for driving two-coil brushless DC fans. Based on advanced Melexis CMOS process, the IC contains a Hall-effect sensor, dynamic offset correction and low side output drivers.

The output drivers OUT1 and OUT2 are fully protected against switching transients. So there is no need for an external zener diode to cut the high voltage spikes induced by the fan coils.

The US90A has an open-drain integrated tachometer FG output that follows the Hall signal. In the US91A, the open-drain rotation detection output RD is active low during normal spinning of the motor. It goes high when the flux switching frequency becomes too low, which means the motor is blocked.

10 Unique features

The absence of a V_{DD} pin enables the two low side output drivers and FG/RD signal output to fit in a four-pin VK package. The lack of a V_{DD} pin decreases also the probability to damage the chip due to reverse voltage connection, using the coil resistance to limit the reverse current. In this condition, the total reverse current is twice the peak current value of the fan used.

The built-in locked-rotor protection will automatically shut off the coil current when the rotor is mechanically blocked, or the rotational speed drops below 60 RPM (4-pole rotor magnet). The fan will try to restart every 1.5 seconds until the obstruction is clear. The On / Off cycling reduces the average stall current to 1/7 normal; this is enough to prevent overheating or damage to most fans. Both the US90A and US91A have this feature.

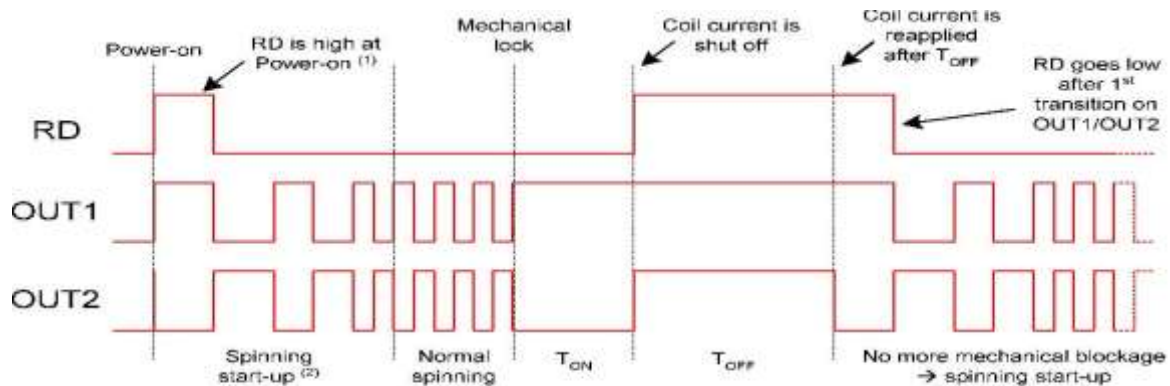

Note 1 : At Power-on, RD is high until the 1st transition on OUT1/OUT2.

Note 2 : The spinning start-up is the ramp between the zero speed and maximal speed. It depends on the motor characteristics.

Note 3 : This graph does not represent the EMF effect.

11 Performance Graphs

11.1 $R_{DS(on)}$ vs T_J

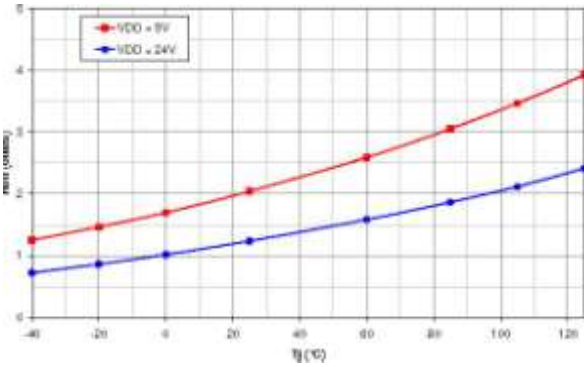

11.2 $R_{DS(on)}$ vs V_{DD}

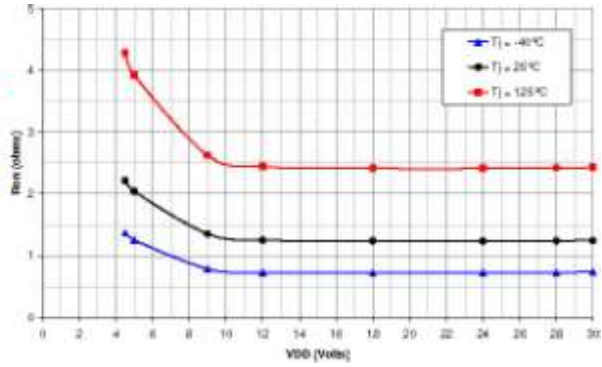

11.3 Magnetic parameters vs T_J

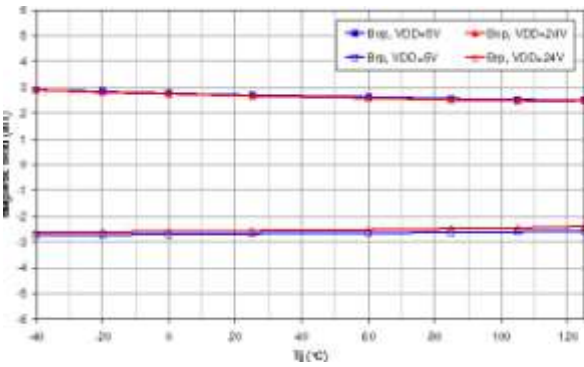

11.4 Magnetic parameters vs V_{DD}

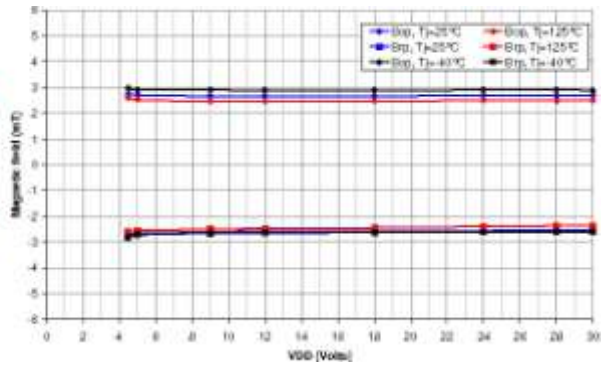

11.5 I_{DD} vs T_J

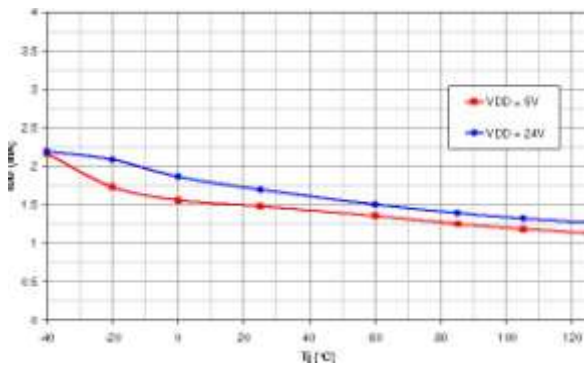

11.6 I_{DD} vs V_{DD}

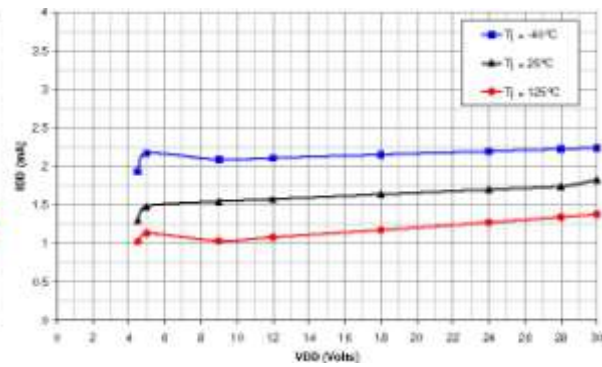

11.7 V_{OL} vs T_J

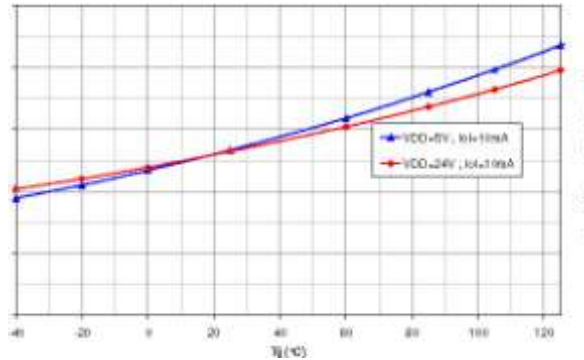

11.8 Power Dissipation vs. T_a

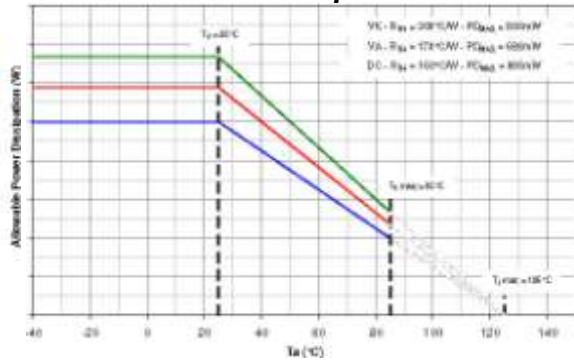

12 Application Information

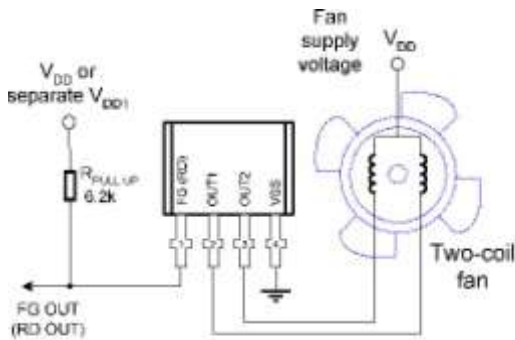

Typical application with pull-up resistor

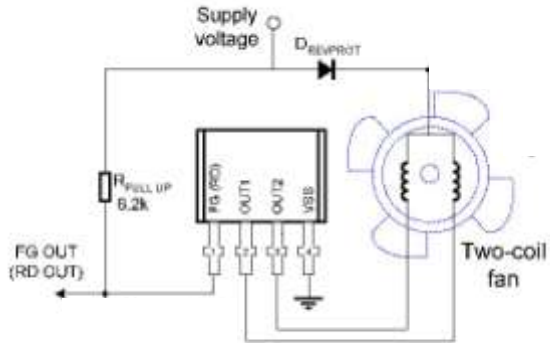

Configuration for reverse voltage protection

The left schematic shows an application including several external protections.

The diode DREVPROT best protects the chip and fan coils for reverse voltage condition.

The no-VDD design enables ESD protection at fan module level to be easily improved. The fan coils prevent and filter fast current stress on OUT1 and OUT2, resulting in better ESD protection.

13 Standard information regarding manufacturability of Melexis products with different soldering processes

Our products are classified and qualified regarding soldering technology, solderability and moisture sensitivity level according to following test methods:

Reflow Soldering SMD's (Surface Mount Devices)

- IPC/JEDEC J-STD-020
Moisture/Reflow Sensitivity Classification for Nonhermetic Solid State Surface Mount Devices (classification reflow profiles according to table 5-2)
- EIA/JEDEC JESD22-A113
Preconditioning of Nonhermetic Surface Mount Devices Prior to Reliability Testing (reflow profiles according to table 2)

Wave Soldering SMD's (Surface Mount Devices) and THD's (Through Hole Devices)

- EN60749-20
Resistance of plastic- encapsulated SMD's to combined effect of moisture and soldering heat
- EIA/JEDEC JESD22-B106 and EN60749-15
Resistance to soldering temperature for through-hole mounted devices

Iron Soldering THD's (Through Hole Devices)

- EN60749-15
Resistance to soldering temperature for through-hole mounted devices

Solderability SMD's (Surface Mount Devices) and THD's (Through Hole Devices)

- EIA/JEDEC JESD22-B102 and EN60749-21
Solderability

For all soldering technologies deviating from above mentioned standard conditions (regarding peak temperature, temperature gradient, temperature profile etc) additional classification and qualification tests have to be agreed upon with Melexis.

The application of Wave Soldering for SMD's is allowed only after consulting Melexis regarding assurance of adhesive strength between device and board.

Melexis is contributing to global environmental conservation by promoting **lead free** solutions. For more information on qualifications of **RoHS** compliant products (RoHS = European directive on the Restriction Of the use of certain Hazardous Substances) please visit the quality page on our website:

<http://www.melexis.com/quality.aspx>

14 ESD Precautions

Electronic semiconductor products are sensitive to Electro Static Discharge (ESD).

Always observe Electro Static Discharge control procedures whenever handling semiconductor products.

15 Package Information

15.1 VK Package Information (4-pin TO92)

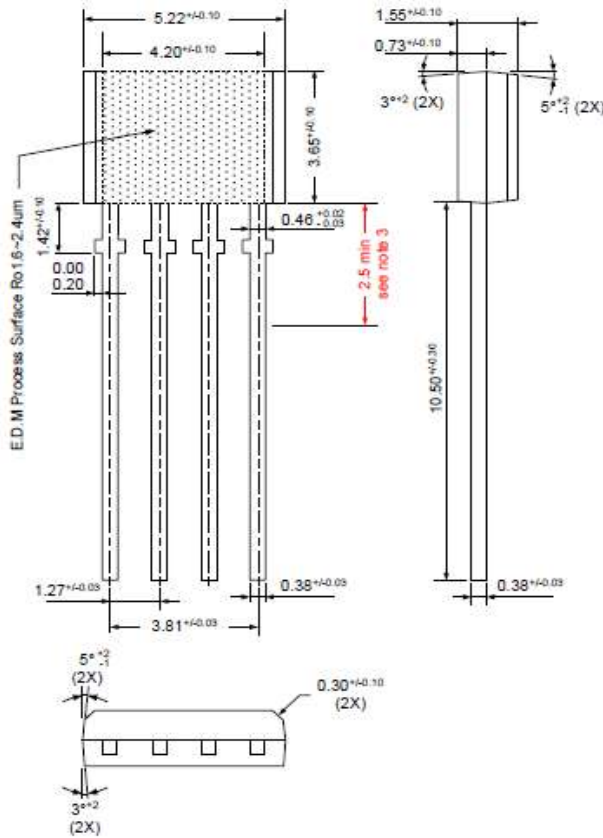

Notes:

1. All dimensions are in millimeters
2. Package dimension exclude molding flash. Mold flash shall not exceed 0.127mm.
3. To preserve reliability, it is recommended to have total lead length equal to 2.5mm minimum, measured from the package line.
4. VK package is a pin through-hole package, hence adapted for wave soldering process. A reflow soldering process is not recommended with VK package as it may seriously affect device reliability.

Marking:

- 1st Line : US90A (US91A) - Name of the device
 2nd Line : xxxx - Assembly lot number (4 last digits)

Hall plate location

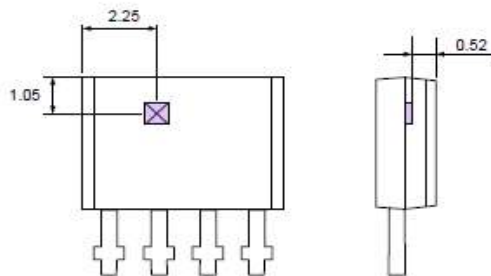

Notes:

1. All dimensions are in millimeters
2. Typical values

15.2 Trimmed VK T&R(dead bug) : VKAAA000-RX

15.2.1 VKAA000-RX Tape

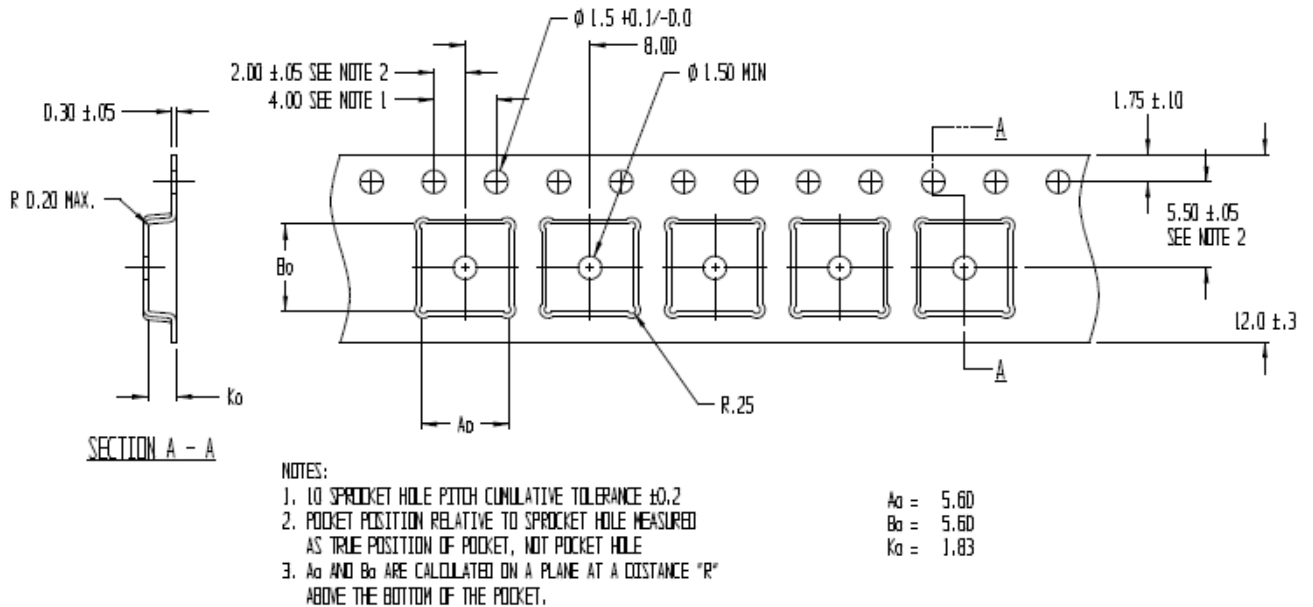

Component is placed face down (dead bug). Marking is face down:

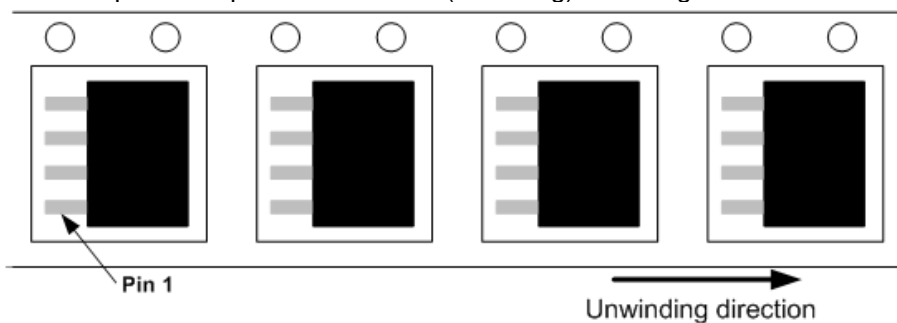

15.2.2 VKAAA000-RX Lead Trim length

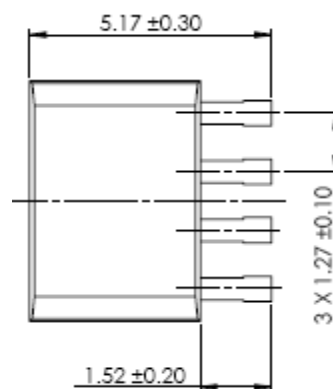

15.3 DC Package Information (8-pin narrow SOIC)

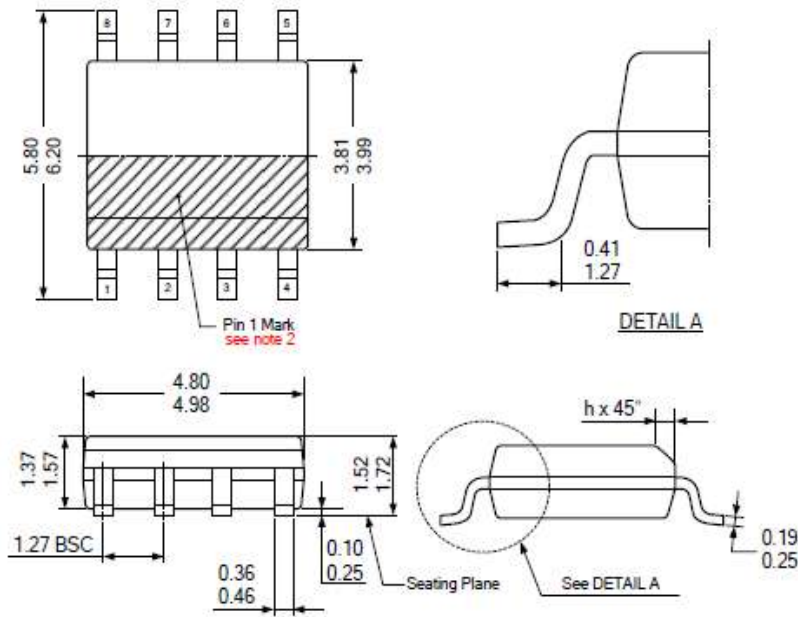

Notes:

1. Controlling dimensions in millimeters
2. Detail of pin #1 identifier are optional but must be located within the zone indicated.
3. Lead coplanarity should be to 0.10mm max.
4. All dimensions exclude mold flashes
End flash from the package body shall not exceed 0.25mm per side.

Marking:

	US90A	US91A
Top Side:		
1 st Line :	US90A	US91A
2 nd Line :	xxxxxxx	xxxxxxx
3 rd Line :	yyww	NA
Bottom Side:		
1 st Line :	US90A	US91A
2 nd Line :	xxxxxxx	xxxxxxx
3 rd Line :	yyww	yyww

yyww : yy = year, ww = week
xxxxxxx : assembly lot#

Hall plate location

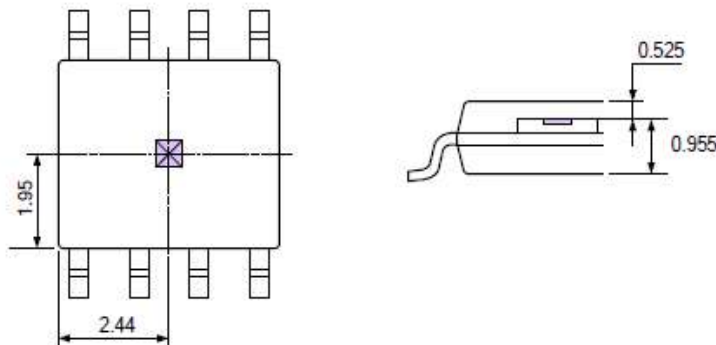

Notes:

1. All dimensions are in millimeters
2. Typical values

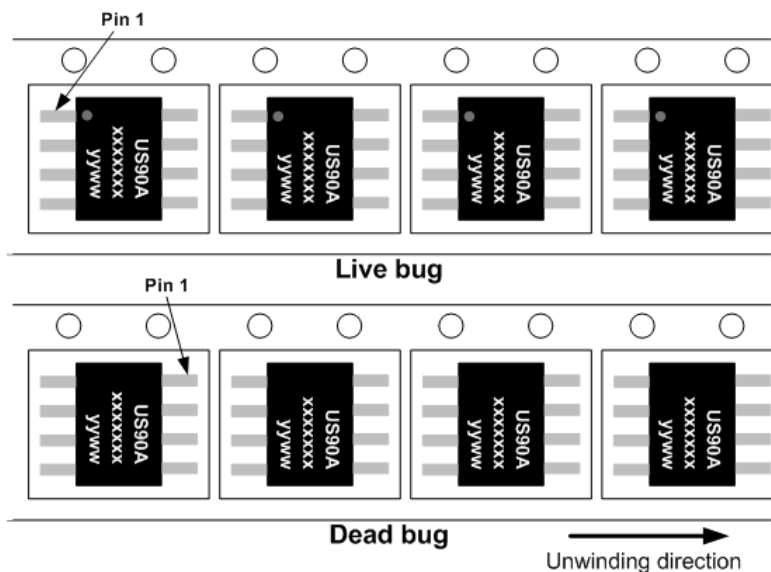

15.4 VA Package Information (4-pin TO92 flat)

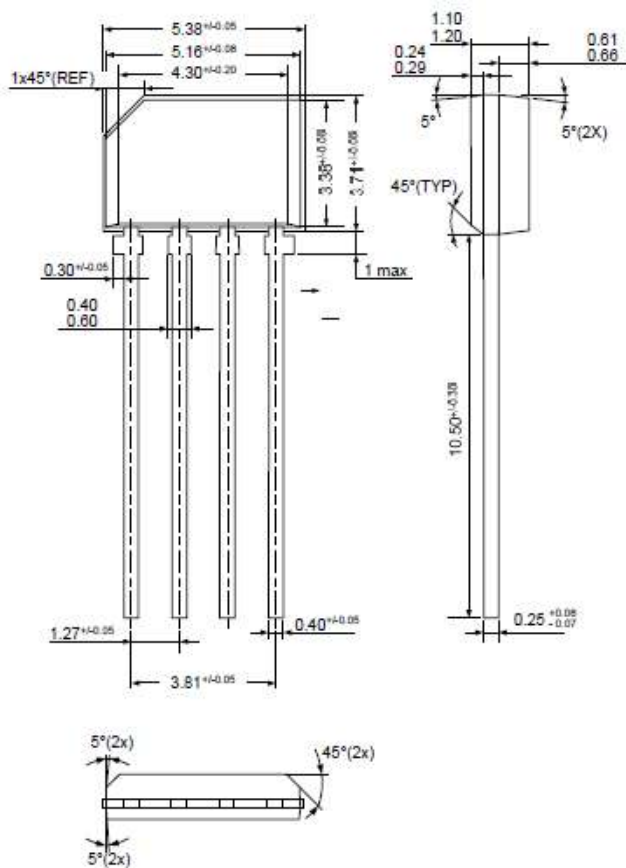

Notes:

1. All dimensions are in millimeters
2. Package dimension exclude end flash

Marking:

Top Side:

1st Line : US90A (US91A) - Name of the device

2nd Line : xxxxxx - Assembly lot number (last 6 digits)

Bottom Side:

yyww : yy = year

ww = week

Hall plate location

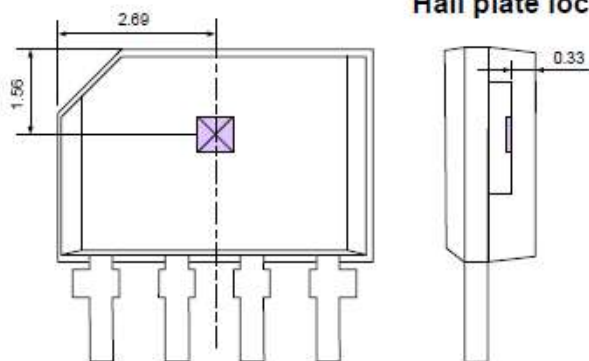

Notes:

1. All dimensions are in millimeters
2. Typical values

16 Disclaimer

Devices sold by Melexis are covered by the warranty and patent indemnification provisions appearing in its Term of Sale. Melexis makes no warranty, express, statutory, implied, or by description regarding the information set forth herein or regarding the freedom of the described devices from patent infringement. Melexis reserves the right to change specifications and prices at any time and without notice. Therefore, prior to designing this product into a system, it is necessary to check with Melexis for current information. This product is intended for use in normal commercial applications. Applications requiring extended temperature range, unusual environmental requirements, or high reliability applications, such as military, medical life-support or life-sustaining equipment are specifically not recommended without additional processing by Melexis for each application.

The information furnished by Melexis is believed to be correct and accurate. However, Melexis shall not be liable to recipient or any third party for any damages, including but not limited to personal injury, property damage, loss of profits, loss of use, interrupt of business or indirect, special incidental or consequential damages, of any kind, in connection with or arising out of the furnishing, performance or use of the technical data herein. No obligation or liability to recipient or any third party shall arise or flow out of Melexis' rendering of technical or other services.

© Melexis NV. All rights reserved.

For the latest version of this document, go to our website at
www.melexis.com

Or for additional information contact Melexis Direct:

Europe, Africa, Asia:
Phone: +32 1367 0495
E-mail: sales_europe@melexis.com

America:
Phone: +1 248 306 5400
E-mail: sales_usa@melexis.com

ISO/TS 16949 and ISO14001 Certified