

DIMENSIONS FOR LARGE POLARIZATION RIB TERMINAL ONLY

NOTES: (UNLESS OTHERWISE SPECIFIED)

1. MATING TERMINAL SHOWN ON SD-33000-001
2. MATERIAL: ASTM B422, UNS C19025, HR04
THICKNESS: 0.30 mm ±0.01
TEMPER: FULL HARD (REF)
TENSILE: 496 MIN MPA
3. TIN PLATED TERMINAL FINISH:
OVERALL UNDERPLATE ELECTRODEPOSITED NICKEL
OVERALL ELECTRODEPOSITED REFLOW TIN
4. GOLD PLATED TERMINAL FINISH
OVERALL UNDERPLATE ELECTRODEPOSITED DUCTILE SULFAMATE NICKEL
CONTACT AREA - ELECTRODEPOSITED GOLD
GRIP AREA - ELECTRODEPOSITED 100% TIN MATTE FINISH
5. SILVER PLATED TERMINAL FINISH
OVERALL UNDERPLATE ELECTRODEPOSITED DUCTILE SULFAMATE NICKEL
CONTACT AREA - ELECTRODEPOSITED PURE SILVER (0.5% MAX IMPURITIES) SEMI-BRIGHT FINISH
- SILVER ANTI-TARNISH : EVABRITE
GRIP AREA - ELECTRODEPOSITED 100% TIN MATTE FINISH
6. MEETS PERFORMANCE SPECIFICATION FOR CABLE TO TERMINAL ELECTRICAL CRIMPS PER SAE/USCAR-21 (8/2001)
7. MEETS PERFORMANCE STANDARD FOR AUTOMOTIVE ELECTRICAL CONNECTOR SYSTEMS FOR SAE/USCAR-2, REV. 4 (TEMP CLASS 3) (5/2004)
8. MEETS ELECTRICAL CONNECTION SYSTEM DESIGN SPECIFICATION (SDS) REV:11 (5/2002)
9. MEETS FIELD CORRELATED LIFE TEST (FCLT) PER SAE/USCAR-20 (6/2004)
10. MEETS WIRING COMPONENT DESIGN GUIDELINES SAE/USCAR-12 REV 2 (12/2001)
11. TSC ON A DIMENSION TO BE INTERPRETED AS DISTANCE TO A THEORETICAL SHARP CORNER AS IF THE RADIUS WERE NOT PRESENT
12. REFERENCE 97BG-14474-AAB FOR LARGE POLARIZATION RIB CAVITY SPECIFICATION
13. INSERTION FORCE (TIN) AVG, FROM PV TESTING =
3.8N LARGE POLARIZATION RIB
3.5N SMALL POLARIZATION RIB (REFERENCE)
14. ALL DIMENSIONS EXCEPT ①, ②, ③ & ④ ARE COMMON TO BOTH SMALL AND LARGE POLARIZATION RIB TERMINALS
15. REFERENCE PK-31300-516 FOR REEL DIRECTION
16. REFERENCE AS-33012-002 FOR CRIMP INFORMATION

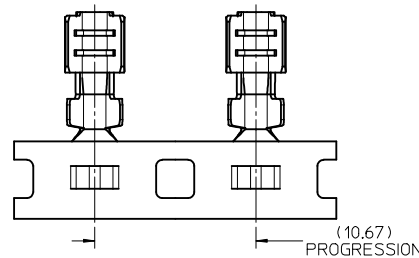
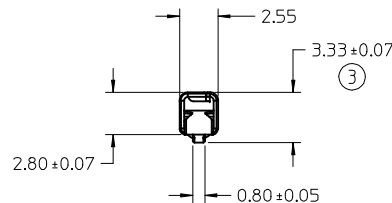

STAMP PLATING TYPE
Sn-TIN, Au-GOLD OR
Ag-SILVER IN THIS
AREA

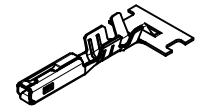
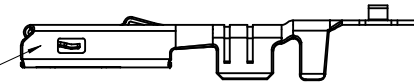

SCALE 2:1

SEE SHEET 5
0.35mm² AND 0.50mm²
ISO WIRE SIZE P/N'S
33012-2004/3004
33001-4005/5005

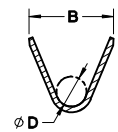
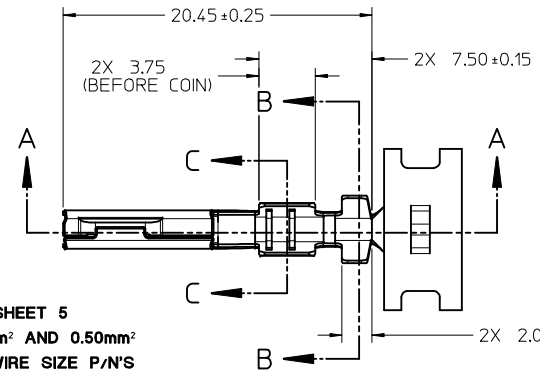

SECTION B-B
SCALE 5:1

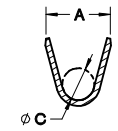
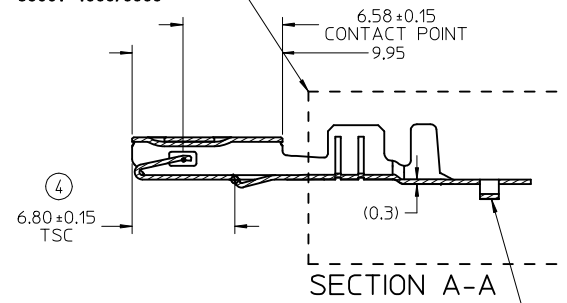

SECTION C-C
SCALE 5:1

CARRIER BUMP DIRECTION
POINTS DOWN FOR TIN PLATED TERMINALS
POINTS UP FOR PRECIOUS PLATED TERMINALS

ENTER DESCRIPTION EC NO: UAU2014-0473 DRWING/ENGIN/S01 2013/09/18 CHKD: APPR:BMOSER 2014/01/03	QUALITY SYMBOLS 	GENERAL TOLERANCES (UNLESS SPECIFIED) <table border="1"> <tr> <th></th> <th>mm</th> <th>INCH</th> </tr> <tr> <td>4 PLACES</td> <td>± 0.10</td> <td>± 0.004</td> </tr> <tr> <td>3 PLACES</td> <td>± 0.005</td> <td>± 0.0002</td> </tr> <tr> <td>2 PLACES</td> <td>± 0.10</td> <td>± 0.004</td> </tr> <tr> <td>1 PLACE</td> <td>± 0.3</td> <td>± 0.012</td> </tr> </table>		mm	INCH	4 PLACES	± 0.10	± 0.004	3 PLACES	± 0.005	± 0.0002	2 PLACES	± 0.10	± 0.004	1 PLACE	± 0.3	± 0.012	DIMENSION STYLE MM ONLY DRAWN BY DATE L. PULLIAM 2005/06/21 CHECKED BY DATE A. DHIR 2005/06/21 APPROVED BY DATE B. MOSER 2005/06/22	SCALE 4:1 TITLE MX150 RECEPTACLE TERMINAL	DESIGN UNITS METRIC 	THIRD ANGLE PROJECTION
		mm	INCH																		
	4 PLACES	± 0.10	± 0.004																		
	3 PLACES	± 0.005	± 0.0002																		
2 PLACES	± 0.10	± 0.004																			
1 PLACE	± 0.3	± 0.012																			
DRAFT WHERE APPLICABLE MUST REMAIN WITHIN DIMENSIONS	MATERIAL NO. SEE TABLE	DOCUMENT NO. SD-33012-002	SHEET NO. 1 OF 5																		
THIS DRAWING CONTAINS INFORMATION THAT IS PROPRIETARY TO MOLEX INCORPORATED AND SHOULD NOT BE USED WITHOUT WRITTEN PERMISSION				MOLEX INCORPORATED																	
MOLEX INCORPORATED																					

FAMILY	GENDER	SEALING	PLATING	PART NUMBER	PAYOFF DIRECTION	GRIP CODE	WIRE SIZES*	A ±0.30	B ±0.30	C ±0.30	D ±0.30	SPECIAL CHARACTERISTICS
MX150	RECEPTACLE	MAT SEAL	Sn	33012-2001	RIGHT (B)	14	16/14AWG	3.9	4.4	1.7	1.6	HIGH PERFORMANCE Sn
				33012-3001	LEFT (D)	14	150-2.00mm ²	3.9	4.4	1.7	1.6	
				33012-2002	RIGHT (B)	18	20/18AWG	3.3	3.1	1.3	1.4	
				33012-3002	LEFT (D)	18	0.75-1.00mm ²	3.3	3.1	1.3	1.4	
				33012-2003	RIGHT (B)	22	22AWG	2.5	2.6	0.9	1.0	
				33012-3003	LEFT (D)	22	22AWG	2.5	2.6	0.9	1.0	
			33012-2004	RIGHT (B)	M3	0.35-0.50mm ²	2.5	2.7	0.9	1.54 ±0.1		
			33012-3004	LEFT (D)	M3	0.35-0.50mm ²	2.5	2.7	0.9	1.54 ±0.1		
			33001-2003	RIGHT (B)	14	16/14AWG	3.9	4.4	1.7	1.6	HIGH PERFORMANCE Au	
			33001-3003	LEFT (D)	14	150-2.00mm ²	3.9	4.4	1.7	1.6		
			33001-2004	RIGHT (B)	18	20/18AWG	3.3	3.1	1.3	1.4		
			33001-3004	LEFT (D)	18	0.75-1.00mm ²	3.3	3.1	1.3	1.4		
			33001-2005	RIGHT (B)	22	22AWG	2.5	2.6	0.9	1.0		
			33001-3005	LEFT (D)	22	22AWG	2.5	2.6	0.9	1.0		
			33001-2006	RIGHT (B)	M3	0.35-0.50mm ²	2.5	2.7	0.9	1.54 ±0.1		
			33001-3006	LEFT (D)	M3	0.35-0.50mm ²	2.5	2.7	0.9	1.54 ±0.1		
			33001-4001	RIGHT (B)	14	16/14AWG	3.9	4.4	1.7	1.6	HIGH PERFORMANCE Ag	
			33001-5001	LEFT (D)	14	150-2.00mm ²	3.9	4.4	1.7	1.6		
33001-4002	RIGHT (B)	18	20/18AWG	3.3	3.1	1.3	1.4					
33001-5002	LEFT (D)	18	0.75-1.00mm ²	3.3	3.1	1.3	1.4					
33001-4003	RIGHT (B)	22	22AWG	2.5	2.6	0.9	1.0					
33001-5003	LEFT (D)	22	22AWG	2.5	2.6	0.9	1.0					
33001-4005	RIGHT (B)	M3	0.35-0.50mm ²	2.5	2.7	0.9	1.54 ±0.1					
33001-5005	LEFT (D)	M3	0.35-0.50mm ²	2.5	2.7	0.9	1.54 ±0.1					

LARGE POLARIZATION RIB - NOT TO BE USED IN MX150 SEALED CONNECTORS

FAMILY	GENDER	SEALING	PLATING	PART NUMBER	PAYOFF DIRECTION	GRIP CODE	WIRE SIZES*	A ±0.30	B ±0.30	C ±0.30	D ±0.30	SPECIAL CHARACTERISTICS
MX150	RECEPTACLE	UNSEALED	Sn	33012-2021	RIGHT (B)	14	16/14AWG	3.9	4.4	1.7	1.6	HIGH PERFORMANCE Sn
				33012-3021	LEFT (D)	14	150-2.00mm ²	3.9	4.4	1.7	1.6	
				33012-2022	RIGHT (B)	18	20/18AWG	3.3	3.1	1.3	1.4	
				33012-3022	LEFT (D)	18	0.75-1.00mm ²	3.3	3.1	1.3	1.4	
				33012-2023	RIGHT (B)	22	22AWG	2.5	2.6	0.9	1.0	
				33012-3023	LEFT (D)	22	0.35-0.50mm ²	2.5	2.6	0.9	1.0	
			33001-2021	RIGHT (B)	14	16/14AWG	3.9	4.4	1.7	1.6	HIGH PERFORMANCE Au	
			33001-3021	LEFT (D)	14	150-2.00mm ²	3.9	4.4	1.7	1.6		
			33001-2022	RIGHT (B)	18	20/18AWG	3.3	3.1	1.3	1.4		
			33001-3022	LEFT (D)	18	0.75-1.00mm ²	3.3	3.1	1.3	1.4		
			33001-2023	RIGHT (B)	22	22AWG	2.5	2.6	0.9	1.0		
			33001-3023	LEFT (D)	22	0.35-0.50mm ²	2.5	2.6	0.9	1.0		
			33001-4021	RIGHT (B)	14	16/14AWG	3.9	4.4	1.7	1.6	HIGH PERFORMANCE Ag	
			33001-5021	LEFT (D)	14	150-2.00mm ²	3.9	4.4	1.7	1.6		
			33001-4022	RIGHT (B)	18	20/18AWG	3.3	3.1	1.3	1.4		
			33001-5022	LEFT (D)	18	0.75-1.00mm ²	3.3	3.1	1.3	1.4		
			33001-4023	RIGHT (B)	22	22AWG	2.5	2.6	0.9	1.0		
			33001-5023	LEFT (D)	22	0.35-0.50mm ²	2.5	2.6	0.9	1.0		

* REFERENCE AS-33012-002 FOR SPECIFIC WIRE TYPES

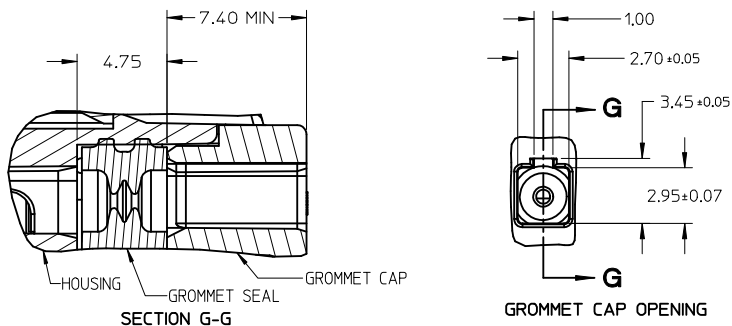

GROMMET SEAL / CAP CONFIGURATION TO MODIFY LARGE POLARIZATION RIB CAVITY TO ACCEPT SMALL POLARIZATION RIB APPLICATIONS

ENTER DESCRIPTION EC NO: UAU2014-0473 DRAWING: JENNINGS01 2013/09/18 CHKD: APPR: BMOSE 2014/01/03	QUALITY SYMBOLS ∇=0 ∇=0 ∇=0	GENERAL TOLERANCES (UNLESS SPECIFIED)		DIMENSION STYLE MM ONLY	SCALE METRIC	DESIGN UNITS METRIC	THIRD ANGLE PROJECTION		
		4 PLACES ± --- ± --- 3 PLACES ± 0.005 ± --- 2 PLACES ± 0.10 ± --- 1 PLACE ± 0.3 ± ---	mm INCH --- --- --- --- --- --- --- ---	DRAWN BY DATE L. PULLIAM 2005/06/21	CHECKED BY DATE A. DHIR 2005/06/21	TITLE MX150 RECEPTACLE TERMINAL			
		APPROVED BY DATE B. MOSER 2005/06/22		MOLEX INCORPORATED		DOCUMENT NO. SD-33012-002		SHEET NO. 2 OF 5	
		DRAFT WHERE APPLICABLE MUST REMAIN WITHIN DIMENSIONS		SEE TABLE		THIS DRAWING CONTAINS INFORMATION THAT IS PROPRIETARY TO MOLEX INCORPORATED AND SHOULD NOT BE USED WITHOUT WRITTEN PERMISSION			

THIS CHECKING - AID IS FOR SMALL POLARIZATION RIB TERMINALS ONLY

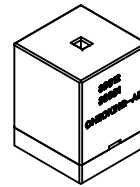

CHECKING - AID ASSEMBLY
SCALE 1:1

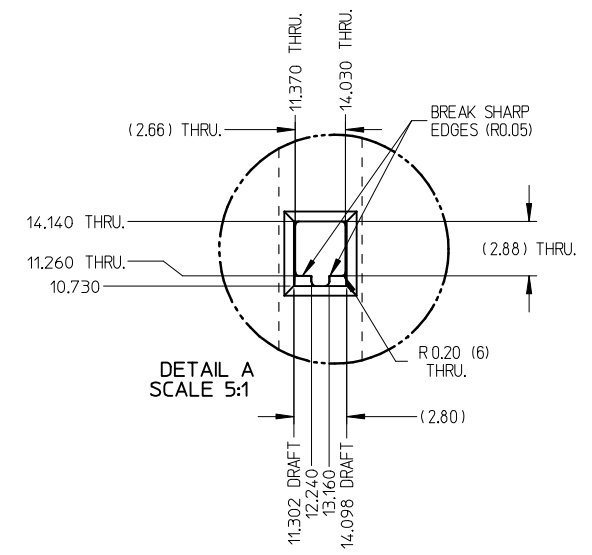
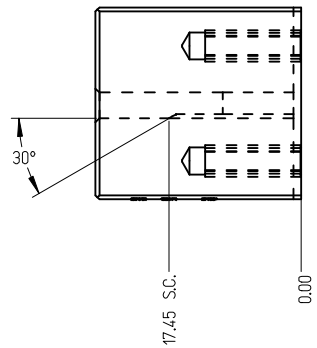
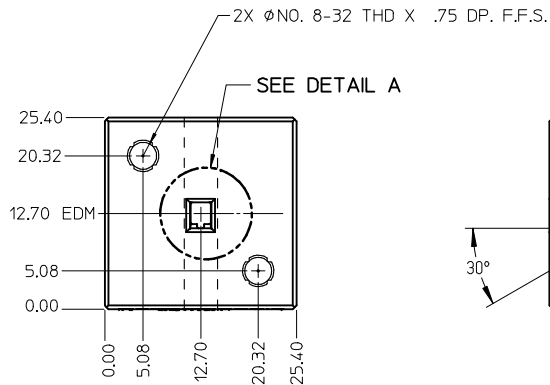

DETAIL A
SCALE 5:1

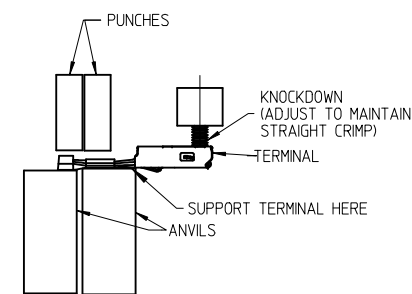
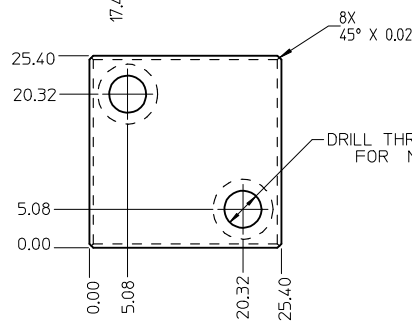
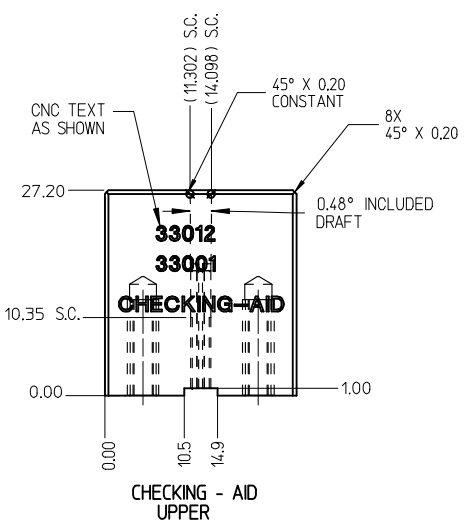

CRIMP REQUIREMENTS:

1. CRIMP STRAIGHTNESS MUST BE MAINTAINED USE A KNOCKDOWN TOOL LOCATED AS SHOWN TERMINAL BOX MUST NOT BE DEFORMED
2. AFTER CRIMPING, THE CRIMPED TERMINAL (AND UP TO 5 mm OF WIRE PAST THE INSULATOR CUTOFF TAB) MUST FIT FREELY INTO THE CHECKING-AID SHOWN ON THIS PAGE
3. FOR OTHER MECHANICAL REQUIREMENTS ON CRIMPED TERMINALS, REFER TO SAE/USCAR-21 (5-13-02) SECTIONS 4.2 (VISUAL INSPECTION), 4.2 (CROSS SECTION ANALYSIS) AND 4.4 (CONDUCTOR CRIMP PULLOUT FORCE)

CHECKING - AID
LOWER

UPPER & LOWER
CHECKING-AID
A2 TOOL STEEL
HARDEN & GRIND
ROCKWELL "C" 56-58

ENTER DESCRIPTION EC NO: UAU2014-0473 DRWNB:JENNINGS01 2013/09/18 CHKD: APPR:BMOSER 2014/01/03 REVISIONS DESCRIPTION 2014/01/03	QUALITY SYMBOLS ▽=0 ▽=0 ▽=0	GENERAL TOLERANCES (UNLESS SPECIFIED) <table border="1"> <tr> <th></th> <th>mm</th> <th>INCH</th> </tr> <tr> <td>4 PLACES</td> <td>± .005</td> <td>± .0005</td> </tr> <tr> <td>3 PLACES</td> <td>± 0.005</td> <td>± .0005</td> </tr> <tr> <td>2 PLACES</td> <td>± 0.10</td> <td>± .005</td> </tr> <tr> <td>1 PLACE</td> <td>± 0.3</td> <td>± .010</td> </tr> </table> ANGULAR ± 3°		mm	INCH	4 PLACES	± .005	± .0005	3 PLACES	± 0.005	± .0005	2 PLACES	± 0.10	± .005	1 PLACE	± 0.3	± .010	DIMENSION STYLE MM ONLY DRAWN BY DATE L. PULLIAM 2005/06/21 CHECKED BY DATE A. DHIR 2005/06/21 APPROVED BY DATE B. MOSER 2005/06/22	SCALE 2:1 TITLE MX150 RECEPTACLE TERMINAL	DESIGN UNITS METRIC	THIRD ANGLE PROJECTION
		mm	INCH																		
	4 PLACES	± .005	± .0005																		
	3 PLACES	± 0.005	± .0005																		
2 PLACES	± 0.10	± .005																			
1 PLACE	± 0.3	± .010																			
DRAFT WHERE APPLICABLE MUST REMAIN WITHIN DIMENSIONS		MATERIAL NO. SEE TABLE	DOCUMENT NO. SD-33012-002	SHEET NO. 3 OF 5	MOLEX INCORPORATED																
THIS DRAWING CONTAINS INFORMATION THAT IS PROPRIETARY TO MOLEX INCORPORATED AND SHOULD NOT BE USED WITHOUT WRITTEN PERMISSION																					
THIS DRAWING CONTAINS INFORMATION THAT IS PROPRIETARY TO MOLEX INCORPORATED AND SHOULD NOT BE USED WITHOUT WRITTEN PERMISSION																					

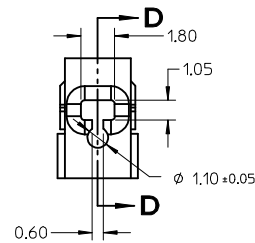
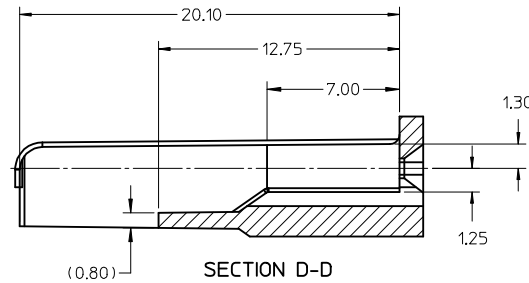
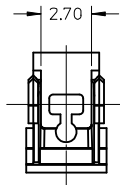

NOTES: UNLESS OTHERWISE SPECIFIED

1. TOLERANCES: LINEAR ± 0.10
ANGULAR $\pm 3^\circ$
2. ALL DRAFT WITHIN TOLERANCE.
3. MAX RADII ON ALL CORNERS SHOWN SHARP: 0.10
4. MAX FLASH PERMISSIBLE: 0.1
5. EJECTOR PIN MARKS PERMISSIBLE IF FLUSH TO 0.25 BELOW SURFACE.
6. MATERIAL: HOUSING/FINGER SPECIFICATION ENGINEERED FOR MATERIAL WITH THE FOLLOWING PROPERTIES:
A. FLEXURAL MODULUS = 4,500 TO 9,400 MPa
PER ASTM TEST D790
B. ELONGATION AT YIELD = 2.3% OR BETTER
PER ASTM TEST D638 TYPE V
7. CAVITY SPEC FOR USE ONLY WITH MOLEX RECEPTACLE
TERMINAL PART NUMBERS SPECIFIED ELSEWHERE ON THIS
DRAWING

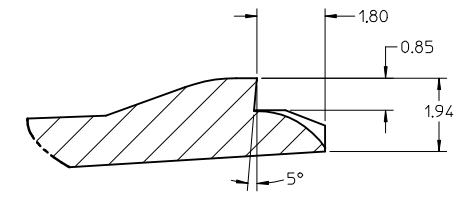
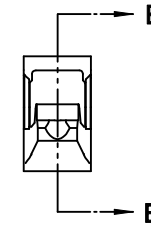
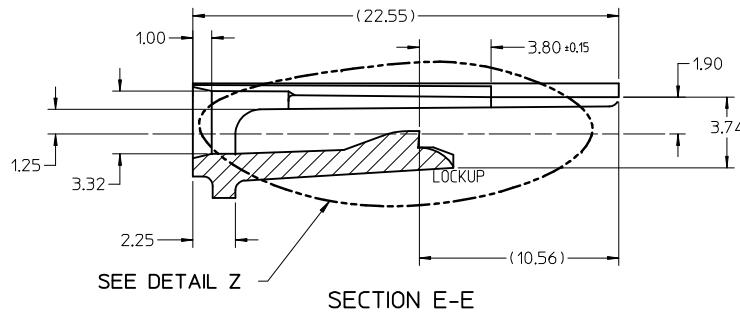
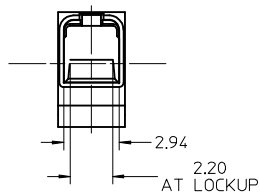

DETAIL Z
SCALE 20:1

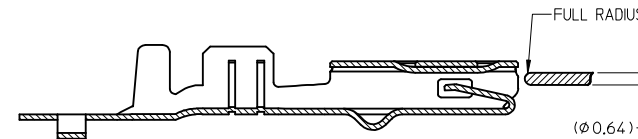
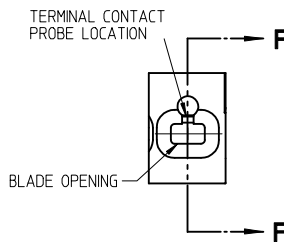
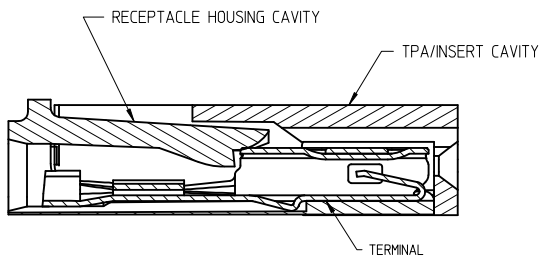

SECTION D-D
FOR LARGE POLARIZATION RIB APPLICATIONS
FIG. 2

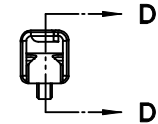

RECEPTACLE CAVITY ASSEMBLED VIEWS
FOR SMALL POLARIZATION RIB APPLICATIONS
FIG. 1

PROBING DOWN THE
THROAT MUST USE
THIS TERMINAL PROBE

FOR PROBING INFORMATION REFERENCE
MOLEX MX150 APPLICATION SPEC AS-33472-100

PREFERRED PROBING LOCATION
IS NOT ON SPRING MEMBER

IF ELECTRICAL CONTINUITY PROBE
TOUCHES SPRING MEMBER USE
PROBING AS SHOWN IN FIG. 2

ENTER DESCRIPTION EC NO: UAU2014-0473 DRWINB/JENNINGS01 2013/09/18 CHKD: APPR:BMOSER 2014/01/03 REV:	QUALITY SYMBOLS	GENERAL TOLERANCES (UNLESS SPECIFIED)	DIMENSION STYLE MM ONLY	SCALE 5:1	DESIGN UNITS METRIC	THIRD ANGLE PROJECTION
	▽=0	4 PLACES ± --- ± ---	DRAWN BY DATE L. PULLIAM 2005/06/21	TITLE MX150 RECEPTACLE TERMINAL		
	▽=0	3 PLACES ± 0.005 ± ---	CHECKED BY DATE A. DHIR 2005/06/21	MATERIAL NO. SD-33012-002		
	▽=0	2 PLACES ± 0.10 ± ---	APPROVED BY DATE B. MOSER 2005/06/22	SHEET NO. 4 OF 5		
		1 PLACE ± 0.3 ± ---	SIZE C	THIS DRAWING CONTAINS INFORMATION THAT IS PROPRIETARY TO MOLEX INCORPORATED AND SHOULD NOT BE USED WITHOUT WRITTEN PERMISSION		
		ANGULAR ± 3°	SEE TABLE			
		DRAFT WHERE APPLICABLE MUST REMAIN WITHIN DIMENSIONS				

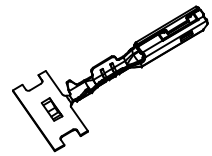

ISO VIEW
SCALE 2:1

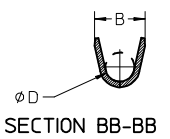
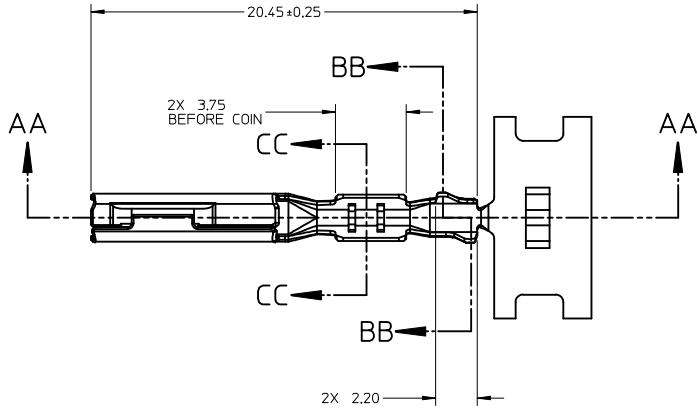

SECTION BB-BB

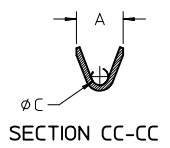

SECTION CC-CC

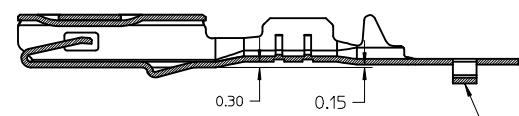
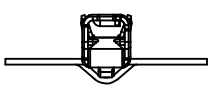

SECTION AA-AA

**P/N'S 33012-2004/3004
33001-4005/5005**

CARRIER BUMP DIRECTION
POINTS DOWN FOR TIN PLATED TERMINAL
POINTS UP FOR PRECIOUS METAL PLATED
TERMINAL

ENTER DESCRIPTION EC NO: UAU2014-0473 DRW:BJENNINGS01 2013/09/18 CHKD: APPR:BMOSER 2014/01/03	QUALITY SYMBOLS ▽=0 ▽=0 ▽=0	GENERAL TOLERANCES (UNLESS SPECIFIED)		DIMENSION STYLE MM ONLY	SCALE 5:1	DESIGN UNITS METRIC	THIRD ANGLE PROJECTION		
		4 PLACES ± --- ± --- 3 PLACES ± 0.005 ± --- 2 PLACES ± 0.10 ± --- 1 PLACE ± 0.3 ± ---	mm INCH	DRAWN BY L. PULLIAM	DATE 2005/06/21	TITLE MX150 RECEPTACLE TERMINAL			
		ANGULAR ± 3°		CHECKED BY A. DHIR	DATE 2005/06/21	APPROVED BY B. MOSER			
		DRAFT WHERE APPLICABLE MUST REMAIN WITHIN DIMENSIONS		MATERIAL NO. SEE TABLE	DATE 2005/06/22	DOCUMENT NO. SD-33012-002	SHEET NO. 5 OF 5		