

# SN74HC4060-Q1

## 14-STAGE ASYNCHRONOUS BINARY COUNTER AND OSCILLATOR

SCLS599 – NOVEMBER 2004

- Qualification in Accordance With AEC-Q100†
- Qualified for Automotive Applications
- Customer-Specific Configuration Control Can Be Supported Along With Major-Change Approval
- Wide Operating Voltage Range of 2 V to 6 V
- Outputs Can Drive up to Ten LSTTL Loads
- Low Power Consumption, 80- $\mu$ A Max  $I_{CC}$
- Typical  $t_{pd} = 14$  ns
- $\pm 4$ -mA Output Drive at 5 V
- Low Input Current of 1  $\mu$ A Max
- Allow Design of Either RC- or Crystal-Oscillator Circuits

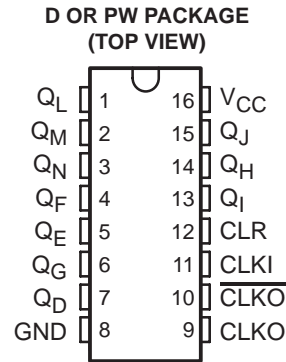

† Contact factory for details. Q100 qualification data available on request.

### description/ordering information

The SN74HC4060 device consists of an oscillator section and 14 ripple-carry binary counter stages. The oscillator configuration allows design of either RC- or crystal-oscillator circuits. A high-to-low transition on the clock (CLKI) input increments the counter. A high level at the clear (CLR) input disables the oscillator ( $\overline{CLKO}$  goes high and CLKO goes low) and resets the counter to zero (all Q outputs low).

### ORDERING INFORMATION

T <sub>A</sub>	PACKAGE‡		ORDERABLE PART NUMBER	TOP-SIDE MARKING
-40°C to 125°C	SOIC – D	Reel of 2500	SN74HC4060QDRQ1	HC4060Q
	TSSOP – PW	Reel of 2000	SN74HC4060QPWRQ1	HC4060Q

‡ Package drawings, standard packing quantities, thermal data, symbolization, and PCB design guidelines are available at [www.ti.com/sc/package](http://www.ti.com/sc/package).

### FUNCTION TABLE (each buffer)

INPUTS		FUNCTION
CLK	CLR	
↑	L	No change
↓	L	Advance to next stage
X	H	All outputs L



Please be aware that an important notice concerning availability, standard warranty, and use in critical applications of Texas Instruments semiconductor products and disclaimers thereto appears at the end of this data sheet.

PRODUCTION DATA information is current as of publication date. Products conform to specifications per the terms of Texas Instruments standard warranty. Production processing does not necessarily include testing of all parameters.



POST OFFICE BOX 655303 • DALLAS, TEXAS 75265

Copyright © 2004, Texas Instruments Incorporated

# SN74HC4060-Q1

## 14-STAGE ASYNCHRONOUS BINARY COUNTER AND OSCILLATOR

SCLS599 – NOVEMBER 2004

### logic diagram (positive logic)

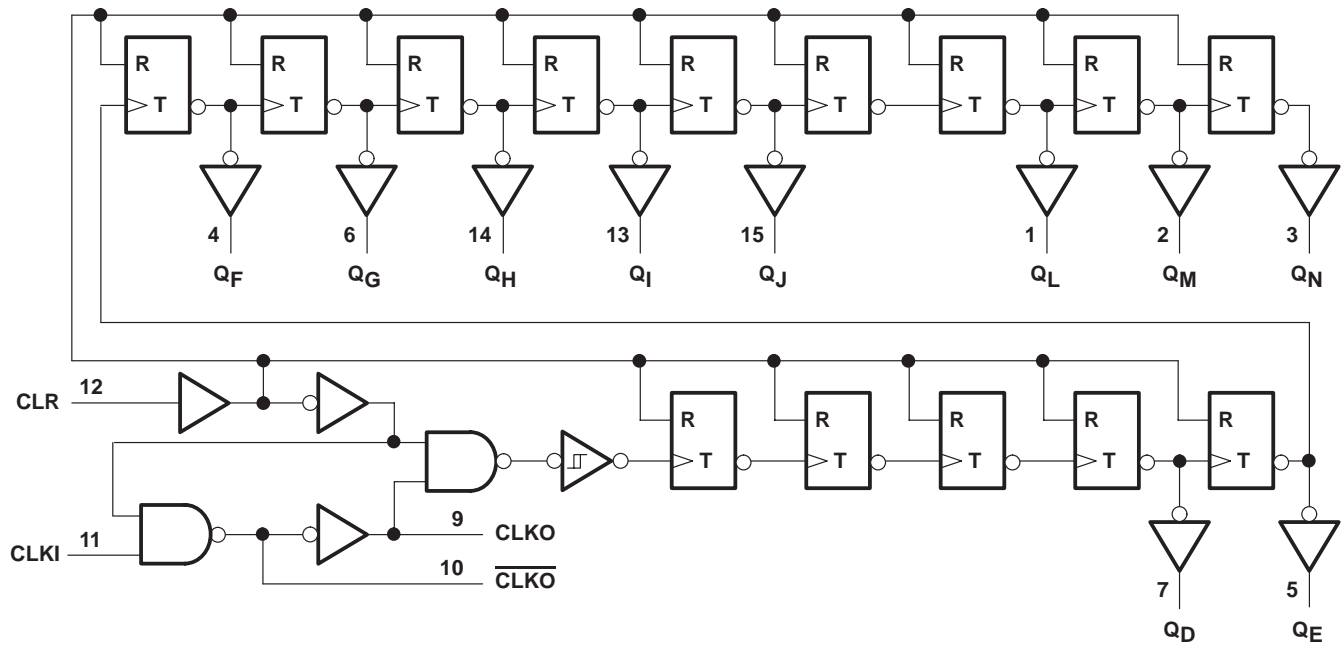

### absolute maximum ratings over operating free-air temperature range (unless otherwise noted)†

Supply voltage range, $V_{CC}$	-0.5 V to 7 V
Input clamp current, $I_{IK}$ ( $V_I < 0$ or $V_I > V_{CC}$ ) (see Note 1)	$\pm 20$ mA
Output clamp current, $I_{OK}$ ( $V_O < 0$ or $V_O > V_{CC}$ ) (see Note 1)	$\pm 20$ mA
Continuous output current, $I_O$ ( $V_O = 0$ to $V_{CC}$ )	$\pm 25$ mA
Package thermal impedance, $\theta_{JA}$ (see Note 2): D package	73°C/W
PW package	108°C/W
Storage temperature range, $T_{stg}$	-65°C to 150°C

† Stresses beyond those listed under “absolute maximum ratings” may cause permanent damage to the device. These are stress ratings only, and functional operation of the device at these or any other conditions beyond those indicated under “recommended operating conditions” is not implied. Exposure to absolute-maximum-rated conditions for extended periods may affect device reliability.

- NOTES: 1. The input and output voltage ratings may be exceeded if the input and output current ratings are observed.  
 2. The package thermal impedance is calculated in accordance with JESD 51-7.

# SN74HC4060-Q1

## 14-STAGE ASYNCHRONOUS BINARY COUNTER AND OSCILLATOR

SCLS599 – NOVEMBER 2004

### recommended operating conditions (see Note 3)

		MIN	NOM	MAX	UNIT
V <sub>CC</sub>	Supply voltage	2	5	6	V
V <sub>IH</sub>	High-level input voltage	V <sub>CC</sub> = 2 V	1.5		V
		V <sub>CC</sub> = 4.5 V	3.15		
		V <sub>CC</sub> = 6 V	4.2		
V <sub>IL</sub>	Low-level input voltage	V <sub>CC</sub> = 2 V	0.5		V
		V <sub>CC</sub> = 4.5 V	1.35		
		V <sub>CC</sub> = 6 V	1.8		
V <sub>I</sub>	Input voltage	0	V <sub>CC</sub>		V
V <sub>O</sub>	Output voltage	0	V <sub>CC</sub>		V
Δt/Δv	Input transition rise/fall time	V <sub>CC</sub> = 2 V	1000		ns
		V <sub>CC</sub> = 4.5 V	500		
		V <sub>CC</sub> = 6 V	400		
T <sub>A</sub>	Operating free-air temperature	-40	125		°C

NOTE 3: All unused inputs of the device must be held at V<sub>CC</sub> or GND to ensure proper device operation. Refer to the TI application report, *Implications of Slow or Floating CMOS Inputs*, literature number SCBA004.

### electrical characteristics over recommended operating free-air temperature range (unless otherwise noted)

PARAMETER		TEST CONDITIONS	V <sub>CC</sub>	T <sub>A</sub> = 25°C			T <sub>A</sub> = -40°C TO 125°C		T <sub>A</sub> = -40°C TO 85°C		UNIT
				MIN	TYP	MAX	MIN	MAX	MIN	MAX	
V <sub>OH</sub>	All outputs	V <sub>I</sub> = V <sub>IH</sub> or V <sub>IL</sub> , I <sub>OH</sub> = -20 μA	2 V	1.9	1.998		1.9		1.9	V	
			4.5 V	4.4	4.499		4.4		4.4		
			6 V	5.9	5.999		5.9		5.9		
	Q outputs	V <sub>I</sub> = V <sub>IH</sub> or V <sub>IL</sub>	I <sub>OH</sub> = -4 mA	4.5 V	3.98	4.3		3.7			3.84
I <sub>OH</sub> = -5.2 mA			6 V	5.48	5.8		5.2		5.34		
V <sub>OL</sub>	All outputs	V <sub>I</sub> = V <sub>IH</sub> or V <sub>IL</sub> , I <sub>OL</sub> = 20 μA	2 V		0.002	0.1		0.1		0.1	V
			4.5 V		0.001	0.1		0.1		0.1	
			6 V		0.001	0.1		0.1		0.1	
	Q outputs	V <sub>I</sub> = V <sub>IH</sub> or V <sub>IL</sub>	I <sub>OL</sub> = 4 mA	4.5 V		0.17	0.26		0.4		
I <sub>OL</sub> = 5.2 mA			6 V		0.15	0.26		0.4		0.33	
I <sub>I</sub>		V <sub>I</sub> = V <sub>CC</sub> or 0	6 V		±0.1	±100		±1000		±1000	nA
I <sub>CC</sub>		V <sub>I</sub> = V <sub>CC</sub> or 0, I <sub>O</sub> = 0	6 V			8		160		80	μA
C <sub>i</sub>			2 V to 6 V		3	10		10		10	pF



# SN74HC4060-Q1

## 14-STAGE ASYNCHRONOUS BINARY COUNTER AND OSCILLATOR

SCLS599 – NOVEMBER 2004

timing requirements over recommended operating free-air temperature range (unless otherwise noted)

		V <sub>CC</sub>	T <sub>A</sub> = 25°C		T <sub>A</sub> = -40°C TO 125°C		T <sub>A</sub> = -40°C TO 85°C		UNIT	
			MIN	MAX	MIN	MAX	MIN	MAX		
f <sub>clock</sub>	Clock frequency	2 V	5.5		3.7		4.3		MHz	
		4.5 V	28		19		22			
		6 V	33		22		25			
t <sub>w</sub>	Pulse duration	CLKI high or low	2 V	90		135		115		ns
			4.5 V	18		27		23		
			6 V	15		23		20		
	CLR high	2 V	90		135		115			
		4.5 V	18		27		23			
		6 V	15		23		20			
t <sub>su</sub>	Setup time, CLR inactive before CLKI↓	2 V	160		240		200		ns	
		4.5 V	32		48		40			
		6 V	27		41		34			

switching characteristics over recommended operating free-air temperature range, C<sub>L</sub> = 50 pF (unless otherwise noted) (see Figure 1)

PARAMETER	FROM (INPUT)	TO (OUTPUT)	V <sub>CC</sub>	T <sub>A</sub> = 25°C			T <sub>A</sub> = -40°C TO 125°C		T <sub>A</sub> = -40°C TO 85°C		UNIT
				MIN	TYP	MAX	MIN	MAX	MIN	MAX	
f <sub>max</sub>			2 V	5.5	10		3.7		4.3	MHz	
			4.5 V	28	45		19		22		
			6 V	33	53		22		25		
t <sub>pd</sub>	CLKI	Q <sub>D</sub>	2 V		240	490		735		615	ns
			4.5 V		58	98		147		123	
			6 V		42	83		125		105	
t <sub>PHL</sub>	CLR	Any Q	2 V		66	140		210		175	ns
			4.5 V		18	28		42		35	
			6 V		14	24		36		30	
t <sub>t</sub>		Any	2 V		28	75		110		95	ns
			4.5 V		8	15		22		19	
			6 V		6	30		19		16	

operating characteristics, T<sub>A</sub> = 25°C

PARAMETER	TEST CONDITIONS	TYP	UNIT
C <sub>pd</sub> Power dissipation capacitance	No load	88	pF



**PARAMETER MEASUREMENT INFORMATION**

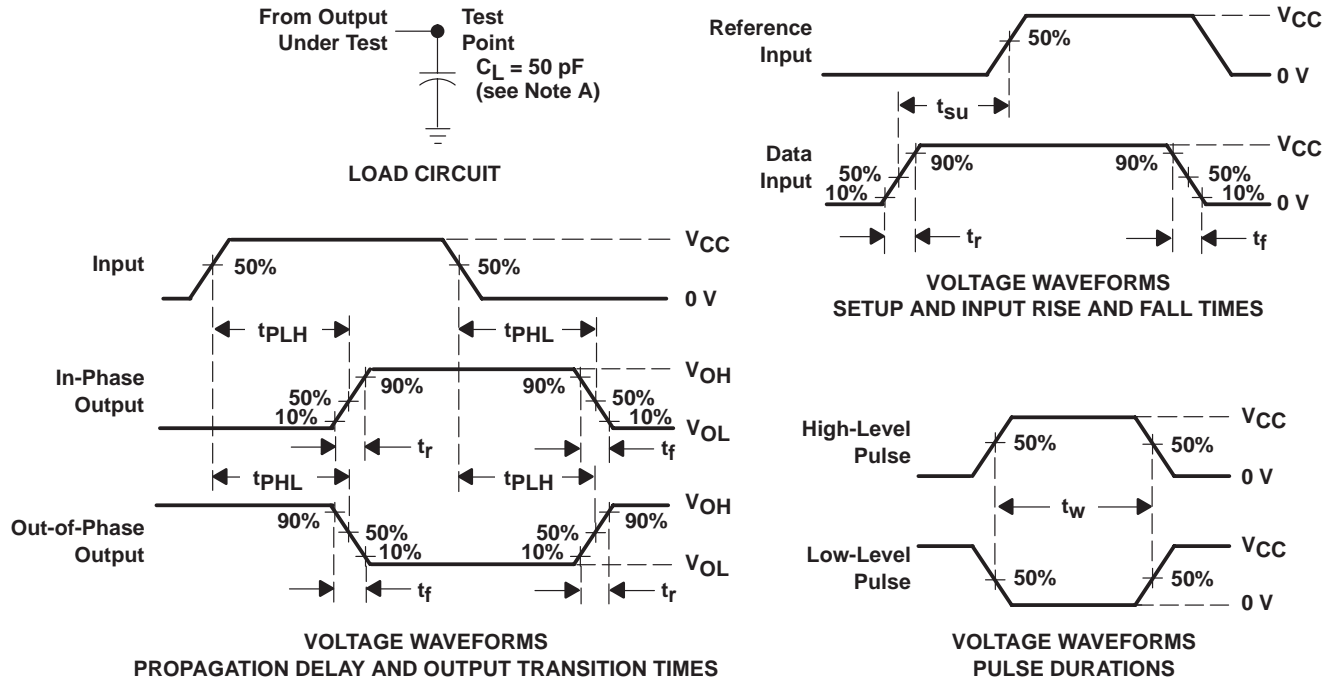

- NOTES: A.  $C_L$  includes probe and test-fixture capacitance.  
 B. Phase relationships between waveforms were chosen arbitrarily. All input pulses are supplied by generators having the following characteristics:  $PRR \leq 1 \text{ MHz}$ ,  $Z_O = 50 \Omega$ ,  $t_r = 6 \text{ ns}$ ,  $t_f = 6 \text{ ns}$ .  
 C. For clock inputs,  $f_{max}$  is measured when the input duty cycle is 50%.  
 D. The outputs are measured one at a time, with one input transition per measurement.  
 E.  $t_{PLH}$  and  $t_{PHL}$  are the same as  $t_{pd}$ .

**Figure 1. Load Circuit and Voltage Waveforms**

# SN74HC4060-Q1

## 14-STAGE ASYNCHRONOUS BINARY COUNTER AND OSCILLATOR

SCLS599 – NOVEMBER 2004

### CONNECTING AN RC-OSCILLATOR CIRCUIT TO THE SN74HC4060 DEVICE

The SN74HC4060 device consists of an oscillator section and 14 ripple-carry binary counter stages. The oscillator configuration allows design of either RC- or crystal-oscillator circuits.

When an RC-oscillator circuit is implemented, two resistors and a capacitor are required. The components are attached to the terminals as shown:

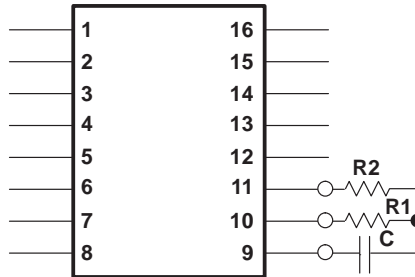

To determine the values of capacitance and resistance necessary to obtain a specific oscillator frequency (f), use this formula:

$$f = \frac{1}{2(R1)(C)\left(\frac{0.405 R2}{R1 + R2} + 0.693\right)}$$

If  $R2 \gg R1$  (i.e.,  $R2 = 10R1$ ), the above formula simplifies to:

$$f = \frac{0.455}{RC}$$

## IMPORTANT NOTICE

Texas Instruments Incorporated and its subsidiaries (TI) reserve the right to make corrections, modifications, enhancements, improvements, and other changes to its products and services at any time and to discontinue any product or service without notice. Customers should obtain the latest relevant information before placing orders and should verify that such information is current and complete. All products are sold subject to TI's terms and conditions of sale supplied at the time of order acknowledgment.

TI warrants performance of its hardware products to the specifications applicable at the time of sale in accordance with TI's standard warranty. Testing and other quality control techniques are used to the extent TI deems necessary to support this warranty. Except where mandated by government requirements, testing of all parameters of each product is not necessarily performed.

TI assumes no liability for applications assistance or customer product design. Customers are responsible for their products and applications using TI components. To minimize the risks associated with customer products and applications, customers should provide adequate design and operating safeguards.

TI does not warrant or represent that any license, either express or implied, is granted under any TI patent right, copyright, mask work right, or other TI intellectual property right relating to any combination, machine, or process in which TI products or services are used. Information published by TI regarding third-party products or services does not constitute a license from TI to use such products or services or a warranty or endorsement thereof. Use of such information may require a license from a third party under the patents or other intellectual property of the third party, or a license from TI under the patents or other intellectual property of TI.

Reproduction of information in TI data books or data sheets is permissible only if reproduction is without alteration and is accompanied by all associated warranties, conditions, limitations, and notices. Reproduction of this information with alteration is an unfair and deceptive business practice. TI is not responsible or liable for such altered documentation.

Resale of TI products or services with statements different from or beyond the parameters stated by TI for that product or service voids all express and any implied warranties for the associated TI product or service and is an unfair and deceptive business practice. TI is not responsible or liable for any such statements.

Following are URLs where you can obtain information on other Texas Instruments products and application solutions:

<b>Products</b>		<b>Applications</b>	
Amplifiers	<a href="http://amplifier.ti.com">amplifier.ti.com</a>	Audio	<a href="http://www.ti.com/audio">www.ti.com/audio</a>
Data Converters	<a href="http://dataconverter.ti.com">dataconverter.ti.com</a>	Automotive	<a href="http://www.ti.com/automotive">www.ti.com/automotive</a>
DSP	<a href="http://dsp.ti.com">dsp.ti.com</a>	Broadband	<a href="http://www.ti.com/broadband">www.ti.com/broadband</a>
Interface	<a href="http://interface.ti.com">interface.ti.com</a>	Digital Control	<a href="http://www.ti.com/digitalcontrol">www.ti.com/digitalcontrol</a>
Logic	<a href="http://logic.ti.com">logic.ti.com</a>	Military	<a href="http://www.ti.com/military">www.ti.com/military</a>
Power Mgmt	<a href="http://power.ti.com">power.ti.com</a>	Optical Networking	<a href="http://www.ti.com/opticalnetwork">www.ti.com/opticalnetwork</a>
Microcontrollers	<a href="http://microcontroller.ti.com">microcontroller.ti.com</a>	Security	<a href="http://www.ti.com/security">www.ti.com/security</a>
		Telephony	<a href="http://www.ti.com/telephony">www.ti.com/telephony</a>
		Video & Imaging	<a href="http://www.ti.com/video">www.ti.com/video</a>
		Wireless	<a href="http://www.ti.com/wireless">www.ti.com/wireless</a>

Mailing Address: Texas Instruments  
Post Office Box 655303 Dallas, Texas 75265