

# TOSHIBA

Leading Innovation >>>

## Motor Control Solutions

### TMPM370FYFG

### Cortex-M3 based Vector Control MCU

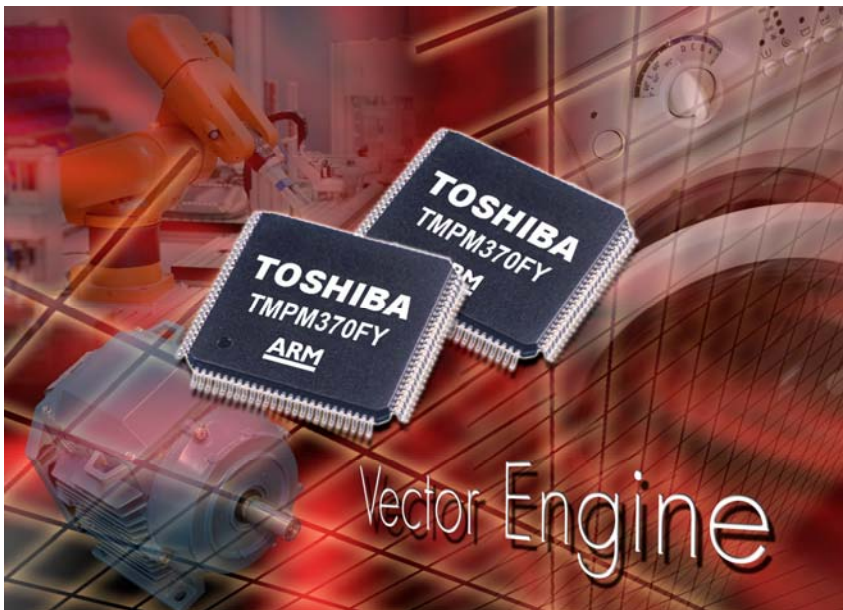

- > Field-Orientated (Vector) Motor Control
- > Sensored and Sensorless Sine Wave
- > Programmable Motor Drive
- > For 3-phase BLDC and AC induction motors
- > Hardware based motor control

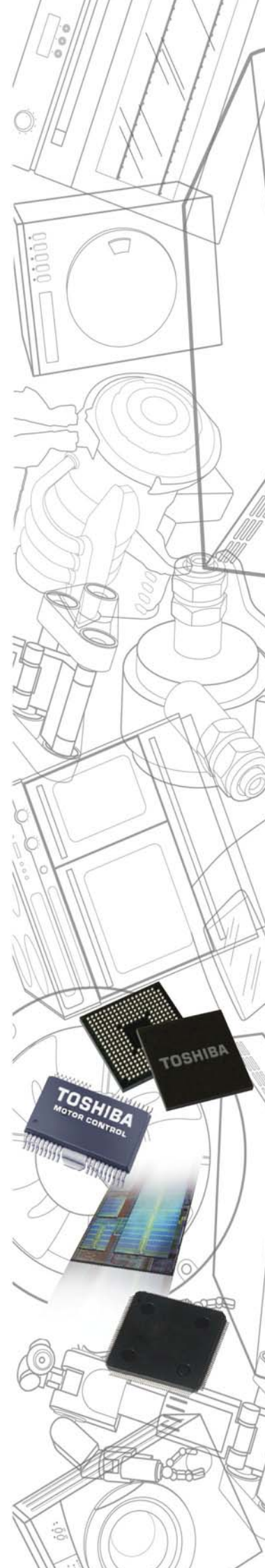

## > Your vector control solution

High Performance Motor Control

The TPM370FYFG is a high-performance ARM Cortex™-M3 based 32-bit microcontrollers that offers accurate, hardware-based vector control of high-end, three-phase motor applications.

Ideal for motion control in home appliances and industrial applications it reduces the need for additional components while providing significant benefits over software-based vector control running on a microcontroller.

It is a compact, highly efficient device that can simplify applications requiring precision control of sensed and sensorless three-phase brushless DC (BLDC) motors or three-phase AC induction motors.

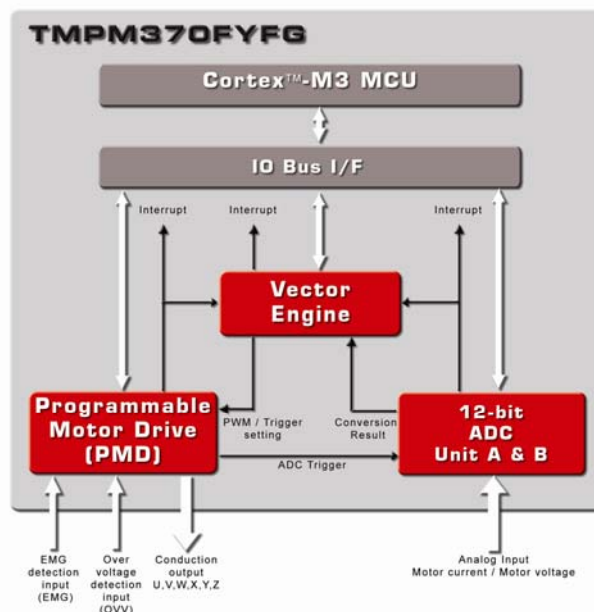

## > TPM370FYFG

**M370**

CPU core (ARM Cortex-M3)

- > Max. operating freq.: 80MHz (PLL x8)
- > Operating voltage: Peripheral I/O = 4.5V ~5.5V
- > Debug circuit: JTAG or SWD
- > Power Saving operation
  - > Clock gear (for dividing clock to 1/2, 1/4, 1/8 or 1/16)
  - > Standby mode (IDLE/STOP)

Built-in functions

- > PMD3+ (Programmable Motor Control)
  - > Timer for motor control: 2 channel
  - > Vector engine: 1 unit
  - > Encoder input: 2 channel
  - > OP-Amplifier: 4 units
  - > Comparator for emergency stop: 2 units
- > 12-bit A/D converter: 2unit (22ch)
- > 16-bit timer counter: 8 channel
- > Serial interface: UART/SIO: 4channel
- > Power On Reset (POR)
- > Voltage Detection (VLTD)
- > Oscillation Frequency detector (OFD)
- > External Interrupt: 16ch

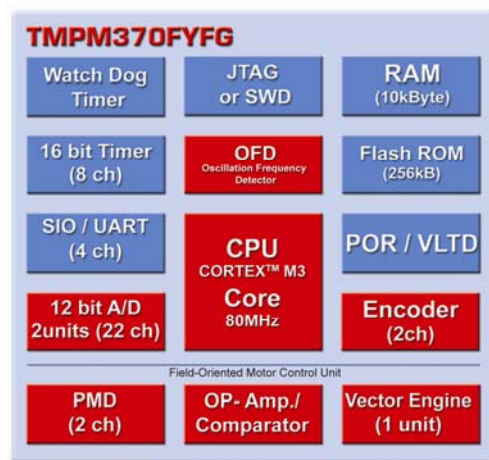

Product	PMD / VE	ROM (kB)	RAM (kB)	Package
TPM370FYFG	2 / 1	256	10	LQFP100 (14x14)
TPM370FYDFG	2 / 1	256	10	QFP100 (14x20)
TPM372FWFG*	1 / 1	128	6	LQFP64 (10x10)
TPM373FWDUG*	1 / 1	128	6	LQFP48 (7x7)
TPM374FWUG*	1 / 1	128	6	LQFP44 (10x10)

\*) Under planning / development

➤ Key Features

FEATURE	CUSTOMERS BENEFIT
Programmable Motor Drive	Hardware based motor control like a co-processor requires less software development and system power. A flexible register control provides automatic settings or a customized control of 3-phase BLDC or induction AC motors. The PMD unit provides a 3phase complementary PWM signal. Up to 150.000 rpm can be supported.
Dual or Single Motor Control	The combination of the 80 MHz CPU with hardware vector calculations and autonomous PWM channels give the M370 MCU the throughput needed to control two motors at the same time.
Vector Engine (FOC)	Field-oriented control of AC motors require extensive mathematical calculations to translate between Id/Iq space and the physical state of the motor. The M370 MCU manages this translation in hardware, freeing up the CPU to run the motor models.
Analogue Circuits	Integrated programmable gain operation amplifier for back EMF detection, comparator for emergency stop and an incremental encoder for rotation direction and position detection, noise filter and three phase sensor input.
Dual 12bit ADC unit	Two A/D converter units with 11 channels each with internal trigger, single/repeat and monitoring function. Fast conversion speed of 2µsec (@40MHz)
Single and three shunt resistor method	For sensorless motor control the motor current has to be measured. TMPM370 is supporting the one shunt and three shunt resistor method.
Oscillation Frequency Detector	Hardware clock monitoring in order to support IEC/EN 60730 classB security standard.
NANO FLASH™	Toshiba's proprietary embedded NANO FLASH™. Quick write/erase and response time; no wait states up to 100MHz.
5V operation voltage	5V single operation voltage supporting industrial and home appliance requirements.
Serial Wire JTAG interface	Debugging interface with an In-Circuit-Emulator (ICE) and the Embedded Trace Macrocell™ (ETM) unit for instruction trace functionality.

TMPM370 integrated hardware motor control

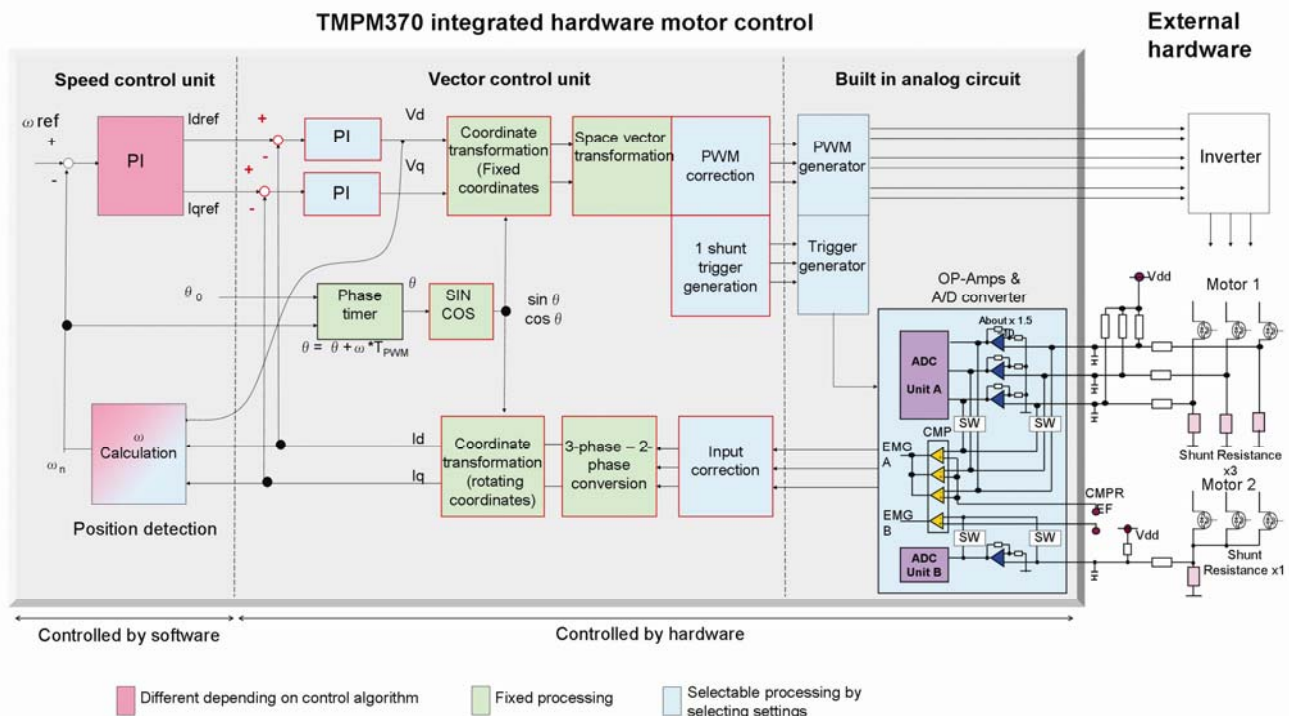



# Optimum Vector Control for Brushless Motors

*Hardware and Software Design for Highest Performance and Lowest Whole-Life Cost*

Field Oriented Control, or Vector Control, is preferred in systems using brushless motors; a number of microcontroller vendors offer FOC software as an aid to motor-control development. A new generation of MCUs that incorporate hardware-based FOC processing now simplifies design challenges as well as achieving higher performance at lower operating frequencies.

## > Brushless Motor Control

Brushless DC motors offer several advantages over traditional brushed AC and DC motors, including lower materials costs, greater reliability, and longer life-time. However, since brushless motors do not self-commutate, torque control, which is fundamental to successful operation of any servo system, presents a more complex challenge. Several strategies have evolved for controlling torque in brushless motors, which perform commutation on the motor's behalf as well as calculating the optimal current for each stator to produce the maximum torque.

Torque control for a brushless motor seeks to maximise torque by adjusting the current in the stator windings to produce a net magnetic field that is orthogonal – or in quadrature – to the rotor field. Any component of the stator field acting parallel to the rotor's field will produce a force that has no turning effect. This direct component wastes energy and places additional stress on the rotor bearings. While maximising the quadrature component, torque control aims to minimise or, ideally, eliminate the direct component to ensure optimal efficiency and reliability. For controlling three-phase brushless motors, having three stator phases positioned at 120-degree intervals around the axis of the

rotor, several commutation techniques are applicable to adjust the current in each phase to produce a net stator field in quadrature with

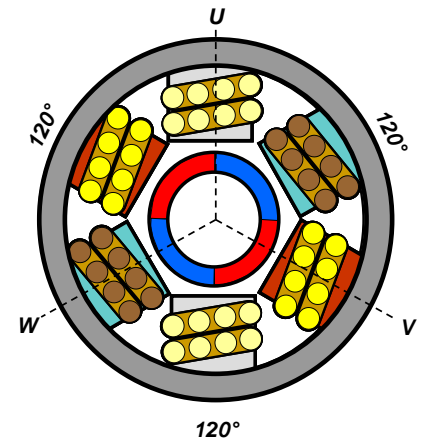

Figure 1: Typical principle of a 3-phase BLDC motor; each phase is positioned on a 120° interval around the axis.

the rotor field. Common to each method of commutation, the motor current is sensed and compared with the desired torque, and a proportional-integral (PI) function then acts on the resulting error signal to generate a correction. This correction signal is subsequently pulse-width modulated and used to control the output bridge of the motor driver.

In trapezoidal motor control, also known as 6-phase motor control, the stator currents have equal magnitude in the two phase pairs either side of the rotor, while the third stator is disconnected from the power source. Rotor-position data from three Hall sensors located in between each pair of stator phases determines which phase is to be disconnected. As the rotor turns the current in each phase is switched between the maximum positive value, zero, and the maximum negative value. The resulting trapezoidal current approximates to a sinusoidal waveform. Although the average stator field in any period is in quadrature

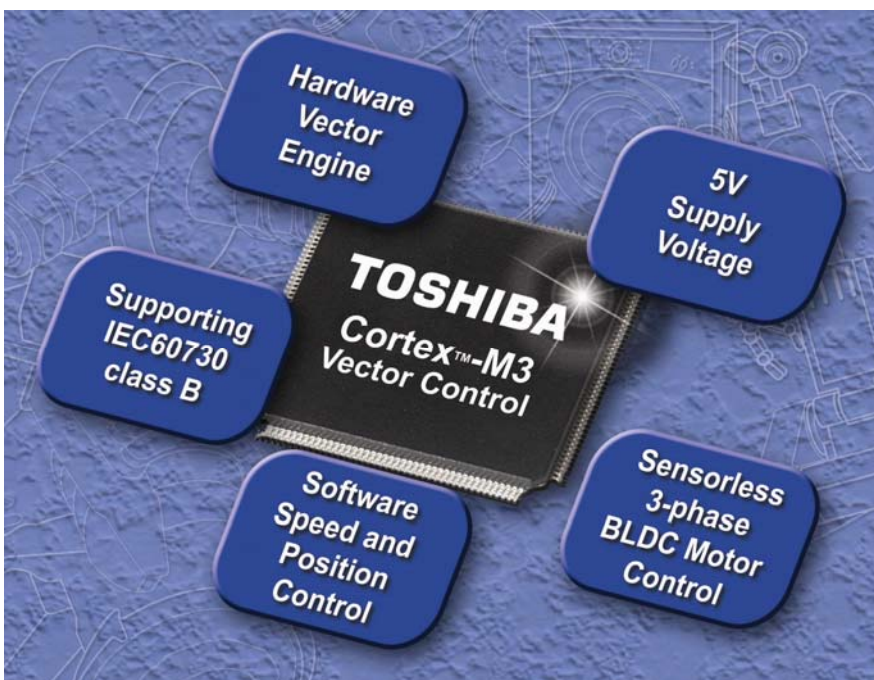

Figure 2: ARM® Cortex™-M3 microcontroller with integrated hardware based vector engine and analog circuit.

with respect to the rotor field, the instantaneous net stator field can lead or lag by up to 30 degrees. At low rotor speeds this results in imprecise control, as well as high levels of audible noise.

> **Sinewave Control**

Sinusoidal control produces smoother torque by applying sinusoidal current waveforms to the stator windings. The currents are mutually phase shifted by 120 degrees, so that the vector sum of the stator field is orthogonal to the rotor field. Compared to trapezoidal control, more accurate rotor position information is required to generate the sinusoidal current waveforms. This may be achieved

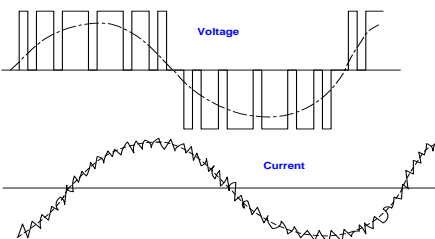

Figure3: PWM motor supply voltage and sinusoidal winding current.

using an angular encoder or, alternatively, using sensorless position detection based on analysis of instantaneous motor current. However, accurate torque control is dependent on rapid computation of the required current value as soon as the rotor position is sensed. At high rotor speeds the limited bandwidth of the PI function results in an increasing lag between the calculated stator current and the actual rotor position, leading to ineffi-

Field Oriented Control (FOC):

Mathematical technique utilized for achieving a separate control (decouple) of the field producing and the torque producing portions of the currents in a three-phase machine. In this scheme Stator current  $I_s$  is decomposed into:

- > Magnetizing current  $I_d$ , producing a magnetic field
- > Quadrature current  $I_q$ , which controls torque.

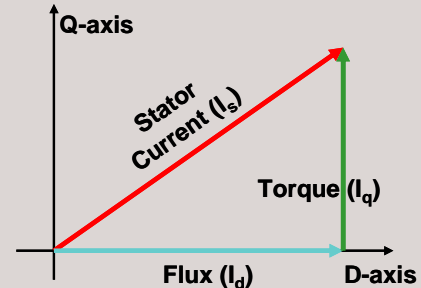

cient operation.

> **Field Oriented Control**

Field Oriented Control (FOC), also known as Vector Control, overcomes the poor low-speed accuracy of trapezoidal control as well as the high-speed inefficiency of sinusoidal control. By manipulating the motor currents and voltages with reference to the rotor's direct and quadrature axes, FOC maintains a constant stator field in quadrature with the rotor field irrespective of any bandwidth limitations of the PI controllers.

In FOC, the sensed stator currents are translated into rotor direct (D) and quadrature (Q) components by a transform function. To achieve maximum torque, the D and Q currents are then compared respectively with zero and the torque requested by the application. The resulting error signals are input to the two PI blocks, which

generate signals in the D-Q reference plane. These must then be transformed into the stator domain to generate the PWM signal for each stator phase. Figure 4 illustrates the functional blocks of a generic FOC function.

Because the inputs to the PI functions are constant, FOC maintains high efficiency at all rotor speeds regardless of any limitations on PI-controller bandwidth. However, to perform FOC in real time requires fast execution of the functions that first transform the sensed stator current signals into the rotor domain and subsequently transform the static PI values into the voltage-control signals for the output bridge. Software-based FOC places maximum demands on CPU performance and operating frequency, to complete the loop within an acceptable time period in relation to rotor speed. Other factors such as integration challenges and any licensing issues must also be borne in mind when developing a motor controller using software-based FOC.

> **Hardware-Based FOC**

Performing time-critical FOC computations in hardware can increase the speed of the control loop, as well as reducing operating frequency and freeing valuable processor cycles to be used for application-level functions. Figure 5 illustrates a re-partitioned FOC function taking advantage of the hardware-based vector-control engine embedded in the Toshiba

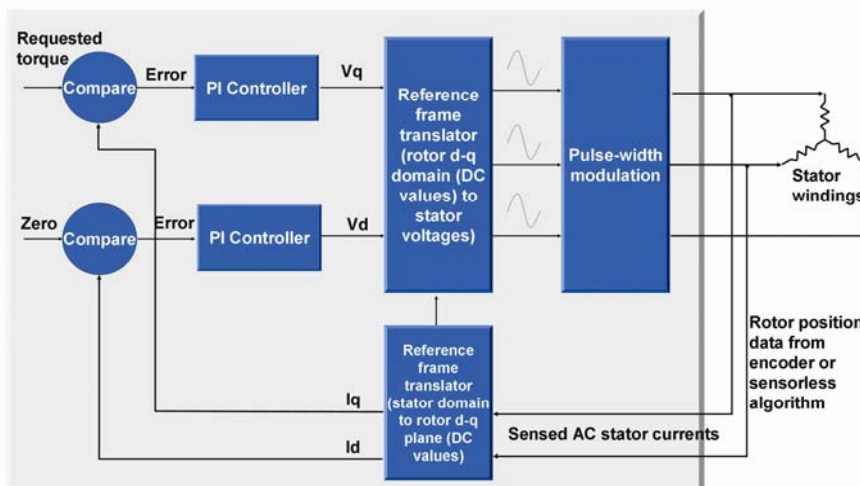

Figure4: Functional block of a generic FOC with sensorless back EMF detection.

TMPM370 and TMPM372 MCU for brushless-motor control. In this scheme, all FOC processing tasks that are fixed and independent of the application are performed in hardware. To perform these functions the MCU's embedded vector engine implements functions including decoding, a scheduler for event and priority control, and calculation resources including a multiply-accumulate (MAC) block for computationally intensive operations. Two vector-control units implement the PI controllers and associated functions.

By offloading the complex and time-critical processing to the vector engine, the TMPM370 restricts the software component of FOC to application-dependent tasks such as  $\omega$  calculation and speed control. These are performed in the device's 32-bit ARM Cortex™-M3 core. With these processing resources, the TMPM370 is able to complete the control loop within each PWM period, resulting in better control stability for PWM frequencies up to 100kHz. Even when operating at 40MHz (max. 80MHz), this MCU is not only capable of controlling two brushless

### Oscillation Frequency Detector (OFD):

TMPM370 group is equipped with an Oscillation Frequency Detector (OFD) which supports IEC60730 class B regulation for Conformity Testing to Standards for Safety of Electrical Equipment. The oscillation frequency detector function is a hardware to monitor CPU clock. This function automatically detects abnormal clock operation without a complex software and secures save operation.

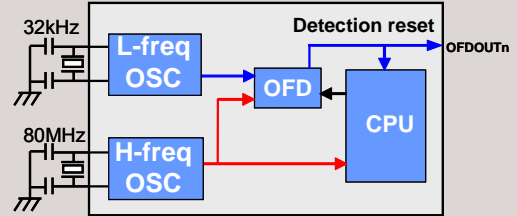

budget and EMI. By complying with the one-MCU-for-one-motor convention, designers can use the TMPM372 operating at 40MHz to take advantage of cost and size savings without affecting performance.

Both M372 and M370 are suitable for high-end motor control applications including next generation of appliances, pumps, industrial machinery, compressors, and HVAC (heating ventilation air-conditioning) systems. Permanent magnet brushless AC/DC, stepper and 3-phase AC induction motors are all suitable for both devices.

grated analogue IP fulfils specific requirements for FOC such as 2x 11-channel 12-bit ADCs for fast current sensing and shutdown capability. An ADC-timing network including op-amp and comparator functions is also integrated, which enables precise measurement over the full positive and negative current range of the motor without requiring an external op-amp to perform level shifting.

### > Conclusion

FOC/VC overcomes the low-speed imprecision of trapezoidal motor control, as well as the high-speed inefficiency experienced with conventional sinusoidal control. In addition to reducing energy consumption, FOC delivers advantages such as lower audible noise, reduced wear, constant torque over the complete speed range including zero-speed operation, and good velocity control under varying load conditions.

Hardware-based execution of the computationally intensive FOC calculations, as well as built-in analogue IP optimised for motor control, avoids the complications and performance limitations experienced when implementing FOC in software.

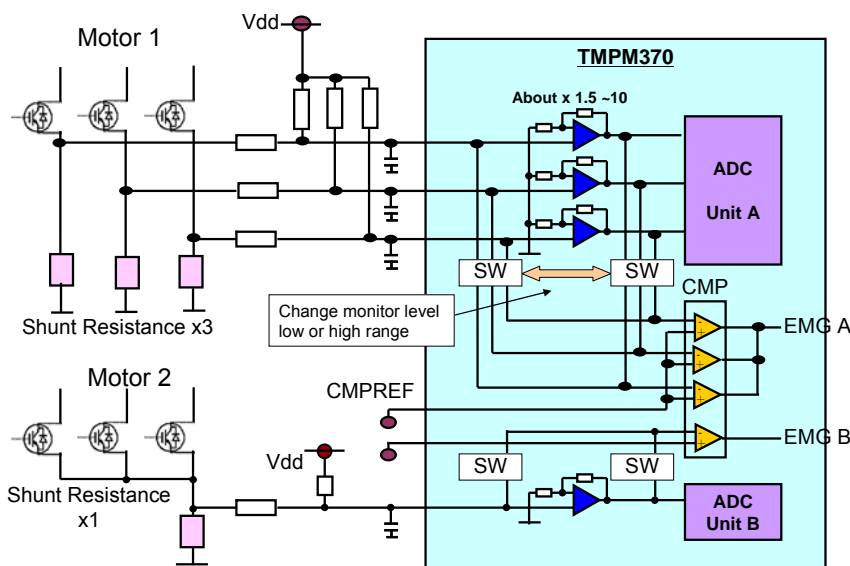

Figure 5: 3-shunt and 1-shunt method supported, integrated op-amps and two separated ADC units.

motors simultaneously, but also has been shown to outperform software-based vector control using a conventional MCU operated at 80MHz, thereby reducing challenges associated with thermal management, system power

Additionally, the TMPM370 and M372 both feature an oscillation frequency detector (OFD), which enables them to meet the IEC60730 class B safety standard.

As well as the vector engine, inte-



**➤ Starter and Evaluation Kit**

The BMSKTOPASM370(HI) is a ready-to-use starter and evaluation kit for motor control solutions requiring field oriented control algorithm. The kit provides an evaluation board, a 18V 3-phase BLDC test-motor, power supply and cables and a comprehensive package of software tools, application samples and documentation.

Key Features:

- Cortex™-M3 core based 32-bit Microcontroller
- Programmable Motor Drive by hardware
- Vector Engine for sensed and sensorless field oriented motor control
- Three shunt and one shunt resistor method supported
- Supporting 3-phase BLDC and AC induction motors
- Low speed vector control
- High torque at zero speed

Kit content:

- TMPM370 Evaluation board
- 18V 3-phase BLDC Motor as test system
- J-Link ARM Lite emulator via USB
- 24V Power Supply (100 to 230V input)
- 18V low voltage motor control provided on board
- Designed for high voltage motor control with available material list
- Safety control functions
- Full isolation to communication circuit
- Small LCD for stand-alone evaluation
- GUI control via PC
- Software package incl. BSP
- Circuit diagram and pcb layout files
- Application notes, documentation and source codes



BMSKTOPASM370(HI) BLDC motor control evaluation kit



Graphical user interface

Application examples:

- |                   |                     |                   |
|-------------------|---------------------|-------------------|
| > Air conditioner | > Water pumps       | > Home appliances |
| > Compressors     | > Kitchen hood      | > Heating pumps   |
| > Fuel pumps      | > Industrial motors | > Robotic         |

In addition to above selection, you can find out more about TOSHIBA's motor control solutions at:  
<http://www.toshiba-components.com/motorcontrol>