



# PCA8565

## Real time clock/calendar

Rev. 02 — 16 June 2009

Product data sheet

## 1. General description

---

The PCA8565 is a CMOS<sup>1</sup> real time clock and calendar optimized for low power consumption. A programmable clock output, interrupt output and voltage-low detector are also provided. All address and data are transferred serially via a two-line bidirectional I<sup>2</sup>C-bus. Maximum bus speed is 400 kbit/s. The built-in word address register is incremented automatically after each written or read data byte.

AEC-Q100 compliant (PCA8565TS) for automotive applications.

## 2. Features

---

- Provides year, month, day, weekday, hours, minutes and seconds based on a 32.768 kHz quartz crystal
- Century flag
- Clock operating voltage: 1.8 V to 5.5 V
- Extended operating temperature range: -40 °C to +125 °C
- Low backup current; typical 0.65 µA at V<sub>DD</sub> = 3.0 V and T<sub>amb</sub> = 25 °C
- 400 kHz two-wire I<sup>2</sup>C-bus interface (at V<sub>DD</sub> = 1.8 V to 5.5 V)
- Programmable clock output for peripheral devices (32.768 kHz, 1.024 kHz, 32 Hz and 1 Hz)
- Alarm and timer functions
- Internal power-on reset
- I<sup>2</sup>C-bus slave address: read A3h and write A2h
- Open-drain interrupt pin
- One integrated oscillator capacitor

## 3. Applications

---

- Automotive
- Industrial
- Other applications that require a wide operating temperature range

---

1. The definition of the abbreviations and acronyms used in this data sheet can be found in [Section 16](#).

## 4. Ordering information

**Table 1. Ordering information**

Type number	Package		
	Name	Description	Version
PCA8565TS	TSSOP8	plastic thin shrink small outline package; 8 leads; body width 3 mm	SOT505-1
PCA8565BS	HVSON10	plastic thermal enhanced very thin small outline package; no leads; 10 terminals; body 3 × 3 × 0.85 mm	SOT650-1

## 5. Marking

**Table 2. Marking codes**

Type number	Marking code
PCA8565TS	8565
PCA8565BS	8565S

6. Block diagram

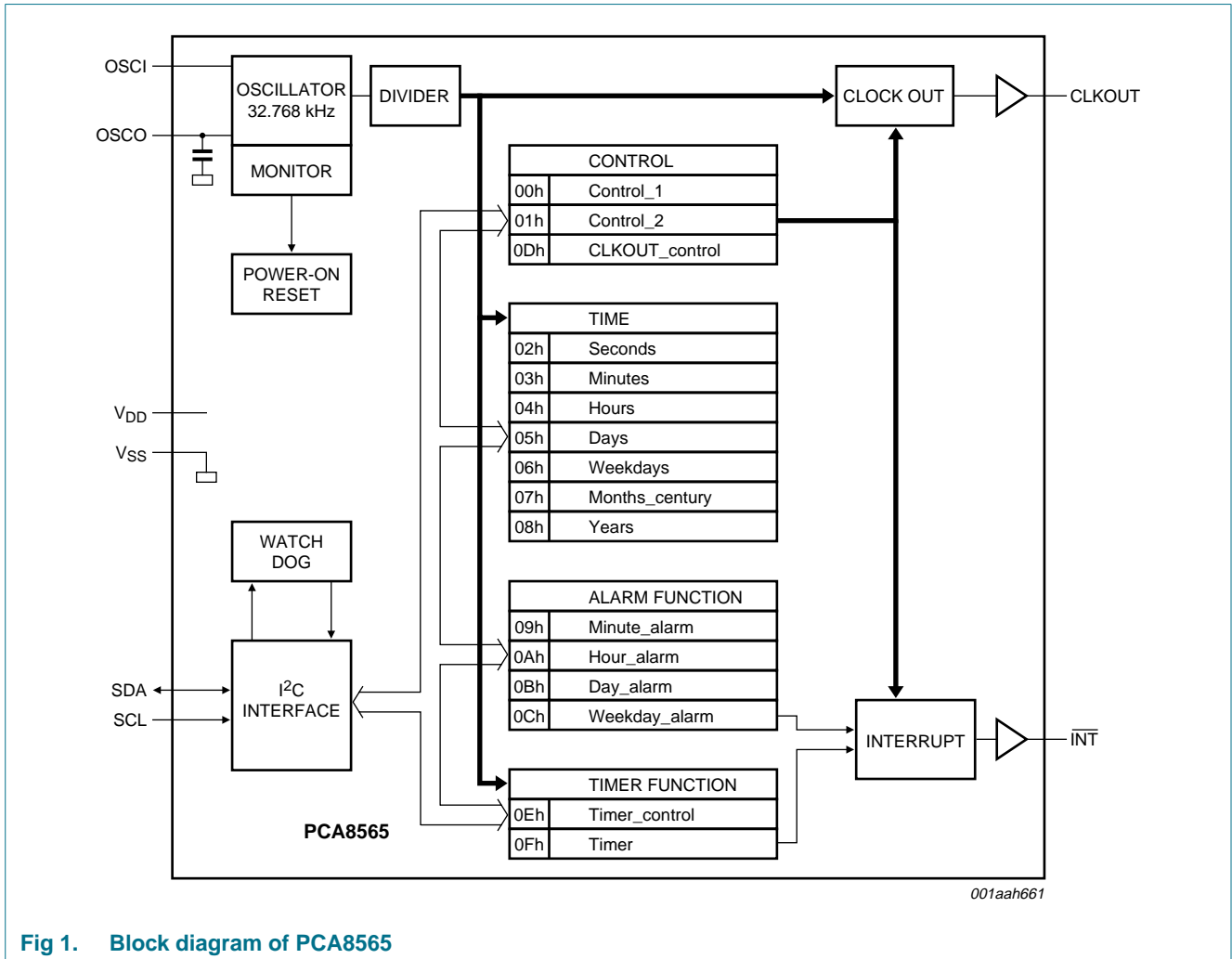
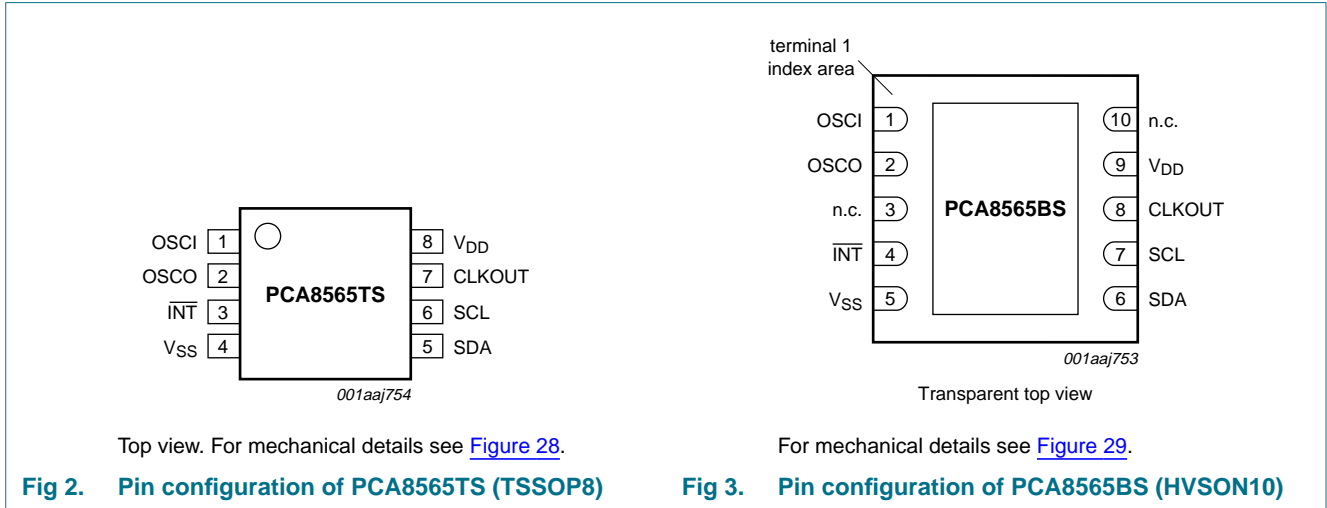

Fig 1. Block diagram of PCA8565

## 7. Pinning information

### 7.1 Pinning



### 7.2 Pin description

Table 3. Pin description

Symbol	Pin		Description
	TSSOP8	HVSON10	
OSCI	1	1	oscillator input
OSCO	2	2	oscillator output
n.c.	-	3, 10	do not connect and do not use as feed through; connect to V <sub>DD</sub> if floating pins are not allowed
INT	3	4	interrupt output (open-drain; active LOW)
V <sub>SS</sub>	4	5 <sup>[1]</sup>	ground
SDA	5	6	serial data I/O
SCL	6	7	serial clock input
CLKOUT	7	8	clock output, open-drain
V <sub>DD</sub>	8	9	positive supply voltage

[1] The die paddle (exposed pad) is wired to V<sub>SS</sub> but should not be electrically connected.

## 8. Device protection diagram

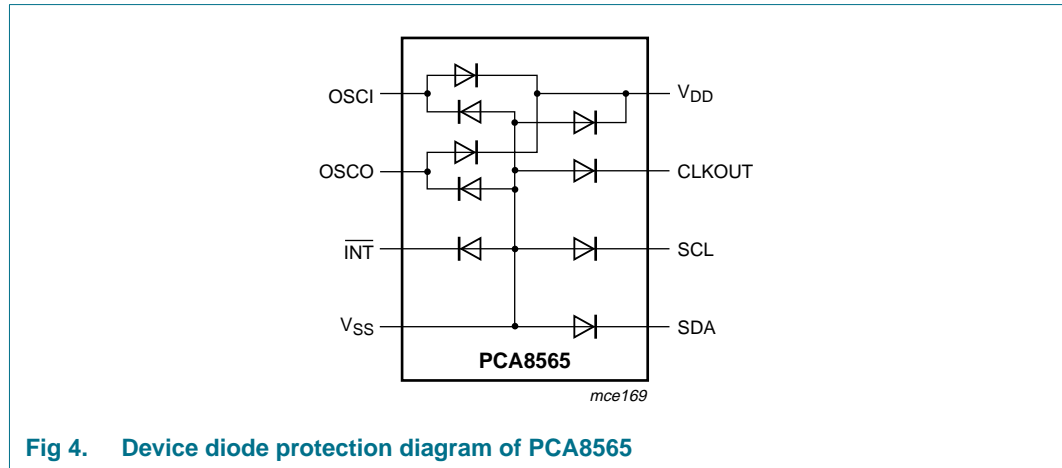

Fig 4. Device diode protection diagram of PCA8565

## 9. Functional description

The PCA8565 contains sixteen 8-bit registers with an auto-incrementing address register, an on-chip 32.768 kHz oscillator with one integrated capacitor, a frequency divider which provides the source clock for the Real Time Clock (RTC), a programmable clock output, a timer, an alarm, a voltage-low detector and a 400 kHz I<sup>2</sup>C-bus interface.

All 16 registers are designed as addressable 8-bit registers although not all bits are implemented:

- The first two registers (memory address 00h and 01h) are used as control and status registers
- The registers at memory addresses 02h through 08h are used as counters for the clock function (seconds up to years counters)
- Address locations 09h through 0Ch contain alarm registers which define the conditions for an alarm
- The register at address 0Dh controls the CLKOUT output frequency
- At address 0Eh is the timer control register and address 0Fh contains the timer value

The arrays SECONDS, MINUTES, HOURS, DAYS, WEEKDAYS, MONTHS, YEARS as well as the bit fields MINUTE\_ALARM, HOUR\_ALARM, DAY\_ALARM and WEEKDAY\_ALARM are all coded in Binary Coded Decimal (BCD) format.

When one of the RTC registers is read the contents of all time counters are frozen. This prevents faulty reading of the clock or calendar during a carry condition (see [Section 10.5.3](#)).

## 9.1 Register overview

**Table 4. Register overview and control bits default values**

Bit positions labeled as - are not implemented. Bit positions labeled as N should always be written with logic 0. Reset values are shown in [Table 7](#).

Address	Register name	Bit							
		7	6	5	4	3	2	1	0
<b>Control registers</b>									
00h	Control_1	TEST1	N	STOP	N	TESTC	N	N	N
01h	Control_2	N	N	N	TL_TP	AF	TF	AIE	TIE
<b>Time and date registers</b>									
02h	Seconds	VL	SECONDS (0 to 59)						
03h	Minutes	-	MINUTES (0 to 59)						
04h	Hours	-	-	HOURS (0 to 23)					
05h	Days	-	-	DAYS (1 to 31)					
06h	Weekdays	-	-	-	-	-	WEEKDAYS (0 to 6)		
07h	Months_century	C	-	-	MONTHS (1 to 12)				
08h	Years	YEARS (0 to 99)							
<b>Alarm registers</b>									
09h	Minute_alarm	AE_M	MINUTE_ALARM (0 to 59)						
0Ah	Hour_alarm	AE_H	-	HOUR_ALARM (0 to 23)					
0Bh	Day_alarm	AE_D	-	DAY_ALARM (1 to 31)					
0Ch	Weekday_alarm	AE_W	-	-	-	-	WEEKDAY_ALARM (0 to 6)		
<b>CLKOUT control register</b>									
0Dh	CLKOUT_control	FE	-	-	-	-	-	FD	
<b>Timer registers</b>									
0Eh	Timer_control	TE	-	-	-	-	-	TD	
0Fh	Timer	COUNTDOWN_TIMER							

## 9.2 Control registers

### 9.2.1 Register Control\_1

Table 5. Register Control\_1 (address 00h) bits description

Bit	Symbol	Value	Description
7	TEST1	0 <sup>[1]</sup>	normal mode
		1	EXT_CLK test mode
6	N	0 <sup>[2]</sup>	default value
5	STOP	0 <sup>[1]</sup>	RTC source clock runs
		1	all RTC divider chain flip-flops are asynchronously set to logic 0; the RTC clock is stopped (CLKOUT at 32.768 kHz is still available)
4	N	0 <sup>[2]</sup>	default value
3	TESTC	0	power-on reset override facility is disabled; set to logic 0 for normal operation
		1 <sup>[1]</sup>	power-on reset override may be enabled
2 to 0	N	000 <sup>[2]</sup>	default value

[1] Default value.

[2] Bits labeled as N should always be written with logic 0.

### 9.2.2 Register Control\_2

Table 6. Register Control\_2 (address 01h) bits description

Bit	Symbol	Value	Description
7 to 5	N	000 <sup>[1]</sup>	default value
4	TI_TP	0 <sup>[2]</sup>	$\overline{\text{INT}}$ is active when TF is active (subject to the status of TIE)
		1	$\overline{\text{INT}}$ pulses active according to <a href="#">Table 26</a> (subject to the status of TIE); <b>Remark:</b> note that if AF and AIE are active then $\overline{\text{INT}}$ will be permanently active
3	AF	0 <sup>[2]</sup>	alarm flag inactive
		1	alarm flag active
2	TF	0 <sup>[2]</sup>	timer flag inactive
		1	timer flag active
1	AIE	0 <sup>[2]</sup>	alarm interrupt disabled
		1	alarm interrupt enabled
0	TIE	0 <sup>[2]</sup>	timer interrupt disabled
		1	timer interrupt enabled

[1] Bits labeled as N should always be written with logic 0.

[2] Default value.

### 9.3 Reset

The PCA8565 includes an internal reset circuit which is active whenever the oscillator is stopped. In the reset state the I<sup>2</sup>C-bus logic is initialized including the address pointer. All other registers are set according to [Table 7](#).

**Table 7. Register reset values<sup>[1]</sup>**

Address	Register name	Bit							
		7	6	5	4	3	2	1	0
00h	Control_1	0	0	0	0	1	0	0	0
01h	Control_2	x	x	0	0	0	0	0	0
02h	Seconds	1	x	x	x	x	x	x	x
03h	Minutes	1	x	x	x	x	x	x	x
04h	Hours	x	x	x	x	x	x	x	x
05h	Days	x	x	x	x	x	x	x	x
06h	Weekdays	x	x	x	x	x	x	x	x
07h	Months_century	x	x	x	x	x	x	x	x
08h	Years	x	x	x	x	x	x	x	x
09h	Minute_alarm	1	x	x	x	x	x	x	x
0Ah	Hour_alarm	1	x	x	x	x	x	x	x
0Bh	Day_alarm	1	x	x	x	x	x	x	x
0Ch	Weekday_alarm	1	x	x	x	x	x	x	x
0Dh	CLKOUT_control	1	x	x	x	x	x	0	0
0Eh	Timer_control	0	x	x	x	x	x	1	1
0Fh	Timer	x	x	x	x	x	x	x	x

[1] Registers labeled 'x' are undefined at power-on and unchanged by subsequent resets.

### 9.4 Time and date registers

The majority of the registers are coded in the BCD format to simplify application use.

**Table 8. Register Seconds (address 02h) bits description**

Bit	Symbol	Value	Place value	Description
7	VL	0	-	clock integrity is guaranteed
		1 <sup>[1]</sup>	-	integrity of the clock information is not guaranteed
6 to 4	SECONDS	0 to 5 <sup>[2]</sup>	ten's place	actual seconds coded in BCD format
3 to 0		0 to 9 <sup>[2]</sup>	unit place	

[1] Start-up value.

[2] Values shown in decimal.



**Table 9. Seconds coded in BCD format**

Seconds value in decimal	Upper-digit (ten's place)			Digit (unit place)			
	Bit 6	Bit 5	Bit 4	Bit 3	Bit 2	Bit 1	Bit 0
00	0	0	0	0	0	0	0
01	0	0	0	0	0	0	1
02	0	0	0	0	0	1	0
:							
09	0	0	0	1	0	0	1
10	0	0	1	0	0	0	0
:							
58	1	0	1	1	0	0	0
59	1	0	1	1	0	0	1

**Table 10. Register Minutes (address 03h) bits description**

Bit	Symbol	Value	Place value	Description
7	-	-	-	unused
6 to 4	MINUTES	0 to 5 <sup>[1]</sup>	ten's place	actual minutes coded in BCD format
3 to 0		0 to 9 <sup>[1]</sup>	unit place	

[1] Values shown in decimal.

**Table 11. Register Hours (address 04h) bits description**

Bit	Symbol	Value	Place value	Description
7 to 6	-	-	-	unused
5 to 4	HOURS	0 to 2 <sup>[1]</sup>	ten's place	actual hours coded in BCD format
3 to 0		0 to 9 <sup>[1]</sup>	unit place	

[1] Values shown in decimal.

**Table 12. Register Days (address 05h) bits description**

Bit	Symbol	Value	Place value	Description
7 to 6	-	-	-	unused
5 to 4	DAYS <sup>[1]</sup>	0 to 3 <sup>[2]</sup>	ten's place	actual day coded in BCD format
3 to 0		0 to 9 <sup>[2]</sup>	unit place	

[1] The PCA8565 compensates for leap years by adding a 29th day to February if the year counter contains a value which is exactly divisible by 4, including the year 00.

[2] Values shown in decimal.

**Table 13. Register Weekdays (address 06h) bits description**

Bit	Symbol	Value	Description
7 to 3	-	-	unused
2 to 0	WEEKDAYS	0 to 6 <sup>[1]</sup>	actual weekday values, see <a href="#">Table 14</a>

[1] Values shown in decimal.

**Table 14. Weekday assignments**

Day <sup>[1]</sup>	Bit		
	2	1	0
Sunday	0	0	0
Monday	0	0	1
Tuesday	0	1	0
Wednesday	0	1	1
Thursday	1	0	0
Friday	1	0	1
Saturday	1	1	0

[1] Definition may be re-assigned by the user.

**Table 15. Register Months\_century (address 07h) bits description**

Bit	Symbol	Value	Place value	Description
7	C <sup>[1]</sup>	0 <sup>[2]</sup>	-	indicates the century is x
		1	-	indicates the century is x + 1
6 to 5	-	-	-	unused
4	MONTHS	0 to 1 <sup>[3]</sup>	ten's place	actual month coded in BCD format, see <a href="#">Table 16</a>
3 to 0		0 to 9 <sup>[3]</sup>	unit place	

[1] This bit may be re-assigned by the user.

[2] This bit is toggled when the years register overflows from 99 to 00.

[3] Values shown in decimal.

**Table 16. Month assignments coded in BCD format**

Month	Upper-digit (ten's place)	Digit (unit place)			
	Bit 4	Bit 3	Bit 2	Bit 1	Bit 0
January	0	0	0	0	1
February	0	0	0	1	0
March	0	0	0	1	1
April	0	0	1	0	0
May	0	0	1	0	1
June	0	0	1	1	0
July	0	0	1	1	1
August	0	1	0	0	0
September	0	1	0	0	1
October	1	0	0	0	0
November	1	0	0	0	1
December	1	0	0	1	0

**Table 17. Register Years (08h) bits description**

Bit	Symbol	Value	Place value	Description
7 to 4	YEARS	0 to 9 <sup>[1]</sup>	ten's place	actual year coded in BCD format
3 to 0		0 to 9 <sup>[1]</sup>	unit place	

[1] Values shown in decimal.

### 9.5 Data flow

Figure 5 shows the data flow and data dependencies starting from the 1 Hz clock tick.

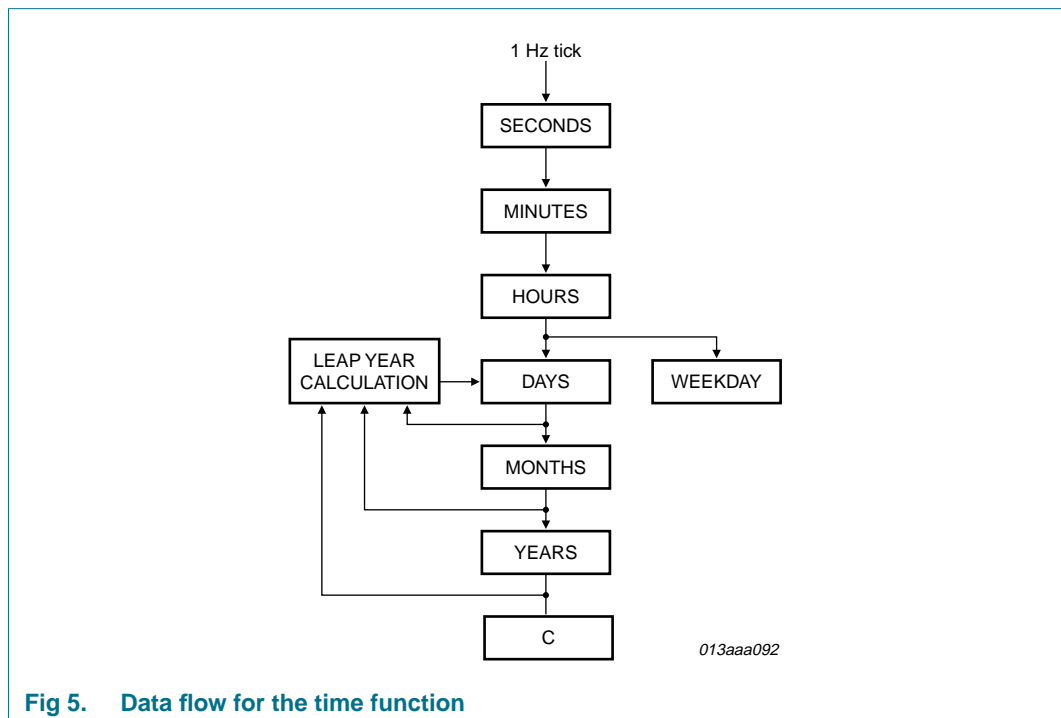

**Fig 5. Data flow for the time function**

If the time registers are written or read by making individual access to the chip, then there is the risk that the time will increment between accesses. This has to be avoided by stopping the increment of the time circuit. After access is completed, the time circuit is allowed to continue running and any request to increment that occurred during the access is initiated.

As a consequence of this method, it is important to read or write all time registers in one access i.e. seconds up to years. Failing to comply with this method could result in the time becoming corrupted.

As an example, if the time (seconds through to hours) are set in one access and then in a second access the date is set, it is possible that the time may increment between the two accesses. A similar problem exists when reading. A roll over may occur between reads thus giving the minutes from one moment and the hours from the next.

Recommended method for reading the time:

1. Send a START condition and the slave address for write (A2h).
2. Set the address pointer to registers Seconds (02h).

3. Send a RESTART condition or STOP followed by START.
4. Send the slave address for read (A3h).
5. Read the register Seconds.
6. Read the register Minutes.
7. Read the register Hours.
8. Read the register Days.
9. Read the register Weekdays.
10. Read the register Months\_century.
11. Read the register Years.
12. Send a STOP condition.

### 9.6 Alarm function

When one or more of the alarm registers are loaded with a valid minute, hour, day or weekday and its corresponding bit alarm enable (AE\_x) is logic 0, then that information is compared with the actual minute, hour, day and weekday.

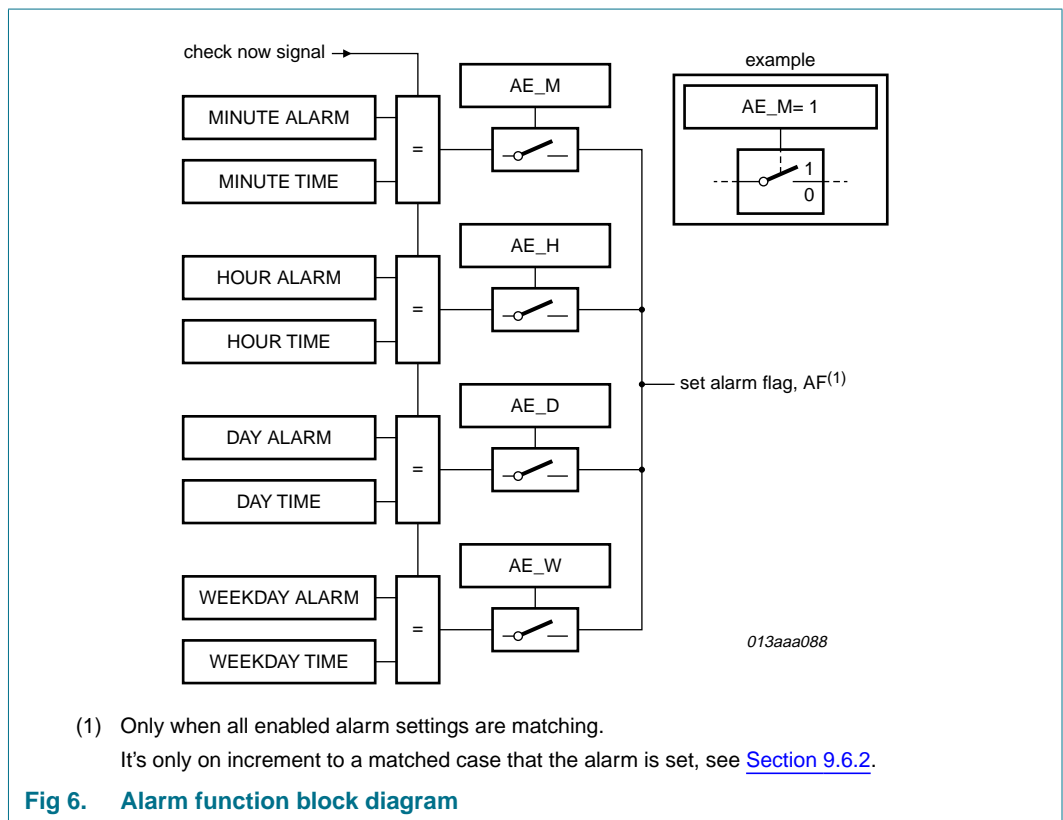

### 9.6.1 Alarm registers

**Table 18. Register Minute\_alarm (address 09h) bits description**

Bit	Symbol	Value	Place value	Description
7	AE_M	0	-	minute alarm is enabled
		1 <sup>[1]</sup>	-	minute alarm is disabled
6 to 4	MINUTE_ALARM	0 to 5 <sup>[2]</sup>	ten's place	minute alarm information coded in BCD format
3 to 0		0 to 9 <sup>[2]</sup>	unit place	

[1] Default value.

[2] Values shown in decimal.

**Table 19. Register Hour\_alarm (address 0Ah) bits description**

Bit	Symbol	Value	Place value	Description
7	AE_H	0	-	hour alarm is enabled
		1 <sup>[1]</sup>	-	hour alarm is disabled
6	-	-	-	unused
5 to 4	HOUR_ALARM	0 to 2 <sup>[2]</sup>	ten's place	hour alarm information coded in BCD format
3 to 0		0 to 9 <sup>[2]</sup>	unit place	

[1] Default value.

[2] Values shown in decimal.

**Table 20. Register Day\_alarm (address 0Bh) bits description**

Bit	Symbol	Value	Place value	Description
7	AE_D	0	-	day alarm is enabled
		1 <sup>[1]</sup>	-	day alarm is disabled
6	-	-	-	unused
5 to 4	DAY_ALARM	0 to 3 <sup>[2]</sup>	ten's place	day alarm information coded in BCD format
3 to 0		0 to 9 <sup>[2]</sup>	unit place	

[1] Default value.

[2] Values shown in decimal.

**Table 21. Register Weekday\_alarm (address 0Ch) bits description**

Bit	Symbol	Value	Description
7	AE_W	0	weekday alarm is enabled
		1 <sup>[1]</sup>	weekday alarm is disabled
6 to 3	-	-	unused
2 to 0	WEEKDAY_ALARM	0 to 6 <sup>[2]</sup>	weekday alarm information coded in BCD format

[1] Default value.

[2] Values shown in decimal.

### 9.6.2 Alarm flag

When all enabled comparisons first match, the Alarm Flag (AF) is set. AF will remain set until cleared using the interface. **Once AF has been cleared it is only set again when the time increments to match the alarm condition once more.**

Alarm registers which have their bit AE\_x at logic 1 are ignored.

Table 23 shows an example for clearing bit AF but leaving bit TF unaffected. Clearing the flags is made by a write command; therefore bits 7, 6, 4, 1 and 0 must be written with their previous values. Repeatedly re-writing these bits has no influence on the functional behavior.

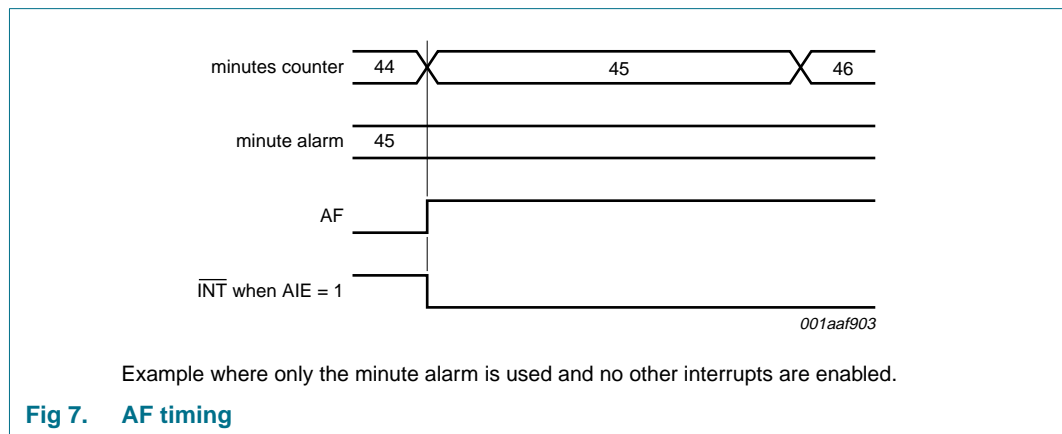

To prevent the timer flags being overwritten while clearing AF, a logical AND is performed during a write access. Writing a logic 1 will cause the flag to maintain its value, whereas writing a logic 0 will cause the flag to be reset.

**Table 22. Flag location in register Control\_2**

Register	Bit							
	7	6	5	4	3	2	1	0
Control_2	-	-	-	-	AF	TF	-	-

The following table shows what instruction must be sent to clear bit AF. In this example bit TF is unaffected.

**Table 23. Example to clear only AF (bit 3) in register Control\_2**

Register	Bit							
	7	6	5	4	3	2	1	0
Control_2	-	-	-	-	0	1	-	-

### 9.7 Timer functions

The 8-bit countdown timer at address 0Fh is controlled by the timer control register at address 0Eh. The timer control register determines one of 4 source clock frequencies for the timer (4.096 kHz, 64 Hz, 1 Hz, or 1/60 Hz) and enables or disables the timer. The timer counts down from a software-loaded 8-bit binary value. At the end of every countdown, the timer sets the timer flag (TF). The TF is cleared using the interface. The asserted TF is used to generate an interrupt (INT). The interrupt is generated as a pulsed signal every countdown period or as a permanently active signal which follows the condition of TF. Bit TI\_TP is used to control this mode selection. When reading the timer, the actual countdown value is returned.

### 9.7.1 Register Timer\_control

Table 24. Register Timer\_control (address 0Eh) bits description

Bit	Symbol	Value	Description
7	TE	0 <sup>[1]</sup>	timer is disabled
		1	timer is enabled
6 to 2	-	-	unused
1 to 0	TD[1:0]		timer source clock frequency select <sup>[2]</sup>
		00	4.096 kHz
		01	64 Hz
		10	1 Hz
		11 <sup>[2]</sup>	1/60 Hz

[1] Default value.

[2] These bits determine the source clock for the countdown timer; when not in use, TD[1:0] should be set to 1/60 Hz for power saving.

The timer register is an 8-bit binary countdown timer. It is enabled and disabled via the bit TE in register Timer\_control. The source clock for the timer is also selected by the TD[1:0] in register Timer\_control. Other timer properties such as interrupt generation are controlled via register Control\_2.

For accurate read back of the countdown value, the I<sup>2</sup>C-bus clock (SCL) must operate at a frequency of at least twice the selected timer clock. Since it is not possible to freeze the countdown timer counter during read back, it is recommended to read the register twice and check for consistent results.

Table 25. Timer (address 0Fh) bits description

Bit	Symbol	Value	Description
7 to 0	COUNTDOWN_TIMER	00h to FFh	countdown value = n;

$$CountdownPeriod = \frac{n}{SourceClockFrequency}$$

## 9.8 Interrupt output

### 9.8.1 Bits TF and AF

When an alarm occurs, AF is set to 1. Similarly, at the end of a timer countdown, TF is set to 1. These bits maintain their value until overwritten using the interface. If both timer and alarm interrupts are required in the application, the source of the interrupt is determined by reading these bits. To prevent one flag being overwritten while clearing another a logic AND is performed during a write access.

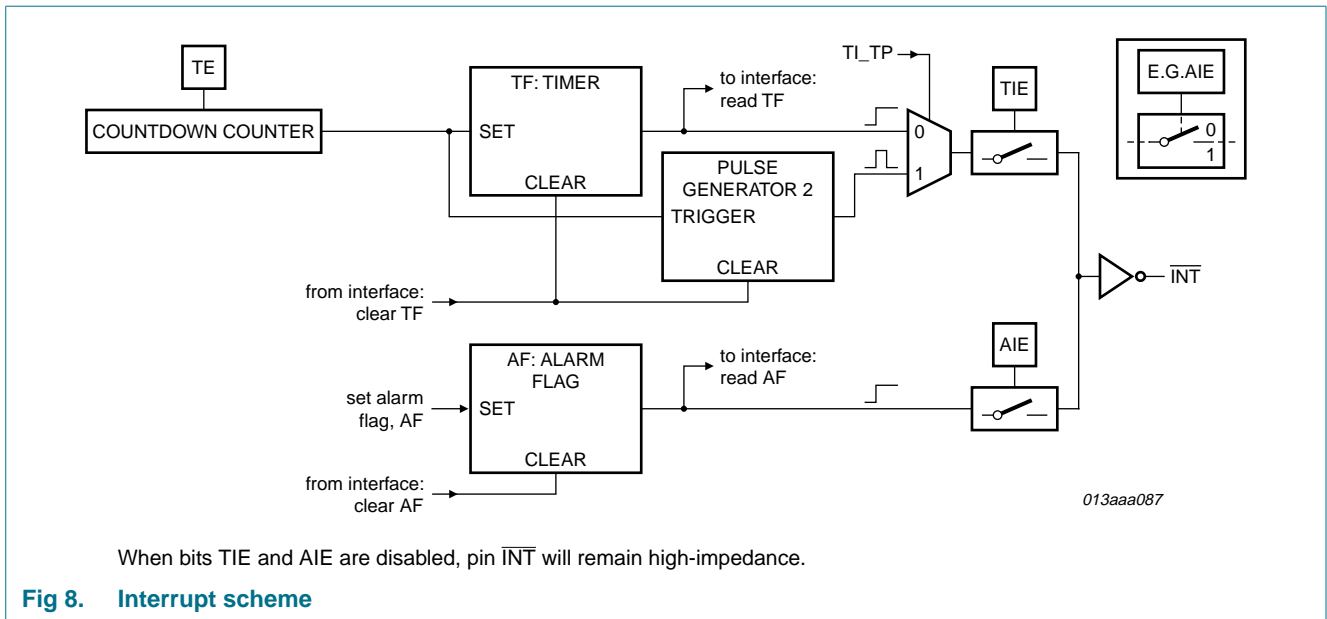

### 9.8.2 Bits TIE and AIE

These bits activate or deactivate the generation of an interrupt when TF or AF is asserted respectively. The interrupt is the logical OR of these two conditions when both AIE and TIE are set.

### 9.8.3 Countdown timer interrupts

The pulse generator for the countdown timer interrupt uses an internal clock and is dependent on the selected source clock for the countdown timer and on the countdown value n. As a consequence, the width of the interrupt pulse varies (see [Table 26](#)).

**Table 26.  $\overline{\text{INT}}$  operation (bit TI\_TP = 1)**

Source clock (Hz)	$\overline{\text{INT}}$ period (s)	
	n = 1 <sup>[1]</sup>	n > 1
4096	$\frac{1}{8192}$	$\frac{1}{4096}$
64	$\frac{1}{128}$	$\frac{1}{64}$
1	$\frac{1}{64}$	$\frac{1}{64}$
$\frac{1}{60}$	$\frac{1}{64}$	$\frac{1}{64}$

[1] n = loaded countdown value. Timer stopped when n = 0.

## 9.9 Clock output

A programmable square wave is available at pin CLKOUT. Operation is controlled by the CLKOUT\_control register at address 0Dh. Frequencies of 32.768 kHz (default), 1.024 kHz, 32 Hz and 1 Hz can be generated for use as a system clock, microcontroller clock, input to a charge pump, or for calibration of the oscillator. CLKOUT is an open-drain output and enabled at power-on. If disabled it becomes high-impedance.



**Table 27. Register CLKOUT\_control (address 0Dh) bits description**

Bit	Symbol	Value	Description
7	FE	0	the CLKOUT output is inhibited and CLKOUT output is set to high-impedance
		1 <sup>[1]</sup>	the CLKOUT output is activated
6 to 2	-	-	unused
1 to 0	FD[1:0]		frequency output at pin CLKOUT
		00 <sup>[1]</sup>	32.768 kHz
		01	1.024 kHz
		10	32 Hz
		11	1 Hz

[1] Default value.

### 9.10 Voltage-low detector

The PCA8565 has an on-chip voltage-low detector. When  $V_{DD}$  drops below  $V_{low}$ , bit VL in the Seconds register is set to indicate that the integrity of the clock information is no longer guaranteed. The VL flag is cleared using the interface.

Bit VL is intended to detect the situation when  $V_{DD}$  is decreasing slowly, for example under battery operation. Should  $V_{DD}$  reach  $V_{low}$  before power is re-asserted then bit VL is set. This indicates that the time may be corrupt (see [Figure 9](#)).

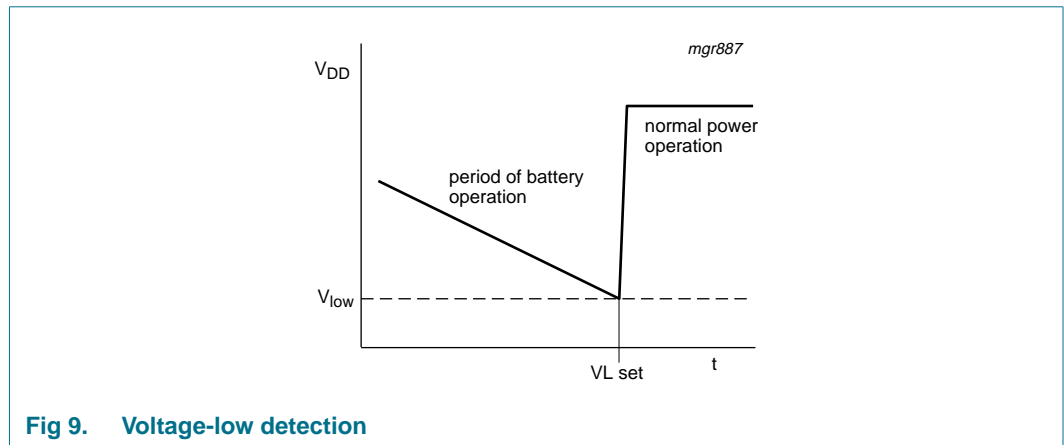

**Fig 9. Voltage-low detection**

### 9.11 External clock (EXT\_CLK) test mode

A test mode is available which allows for on-board testing. In such a mode it is possible to set up test conditions and control the operation of the RTC.

The test mode is entered by setting bit TEST1 in register Control\_1. Then pin CLKOUT becomes an input. The test mode replaces the internal 64 Hz signal with the signal applied to pin CLKOUT. Every 64 positive edges applied to pin CLKOUT will then generate an increment of one second.

The signal applied to pin CLKOUT should have a minimum pulse width of 300 ns and a minimum period of 1000 ns. The internal 64 Hz clock, now sourced from CLKOUT, is divided down to 1 Hz by a 2<sup>6</sup> divide chain called a pre-scaler. The pre-scaler can be set into a known state by using bit STOP. When bit STOP is set, the pre-scaler is reset to 0 (STOP must be cleared before the pre-scaler can operate again).

From a STOP condition, the first 1 second increment will take place after 32 positive edges on CLKOUT. Thereafter, every 64 positive edges will cause a 1 second increment.

**Remark:** Entry into EXT\_CLK test mode is not synchronized to the internal 64 Hz clock. When entering the test mode, no assumption as to the state of the pre-scaler can be made.

Operation example:

1. Set EXT\_CLK test mode (Control\_1, bit TEST1 = 1).
2. Set STOP (Control\_1, bit STOP = 1).
3. Clear STOP (Control\_1, bit STOP = 0).
4. Set time registers to desired value.
5. Apply 32 clock pulses to CLKOUT.
6. Read time registers to see the first change.
7. Apply 64 clock pulses to CLKOUT.
8. Read time registers to see the second change.

Repeat 7 and 8 for additional increments.

### 9.12 STOP bit function

The function of the STOP bit is to allow for accurate starting of the time circuits. The STOP bit function will cause the upper part of the prescaler (F<sub>2</sub> to F<sub>14</sub>) to be held in reset and thus no 1 Hz ticks will be generated (see Figure 10). The time circuits can then be set and will not increment until the STOP bit is released (see Figure 11 and Table 28).

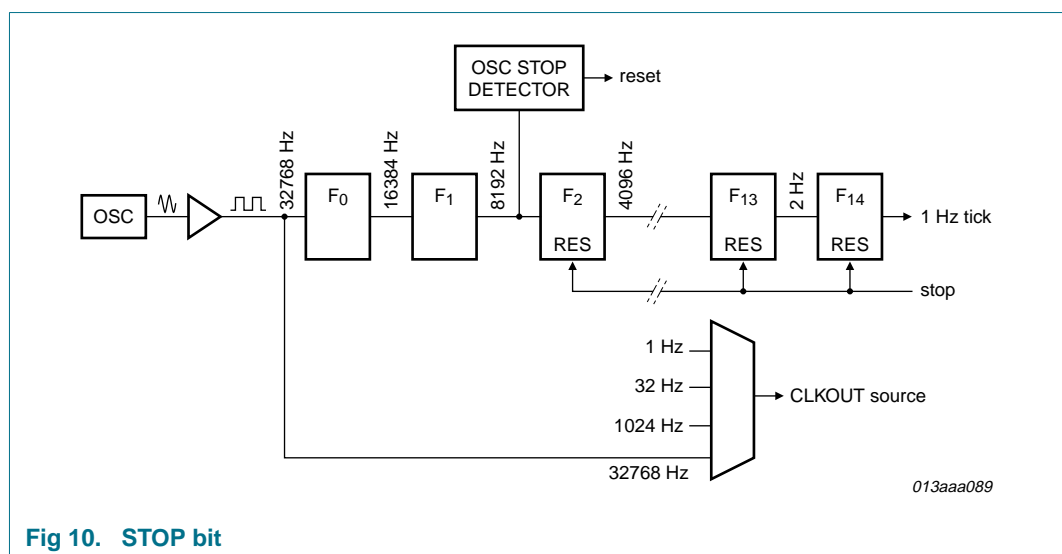

Fig 10. STOP bit

The STOP bit function will not affect the output of 32.768 kHz but will stop 1.024 kHz, 32 Hz and 1 Hz.

The lower two stages of the prescaler ( $F_0$  and  $F_1$ ) are not reset and because the I<sup>2</sup>C-bus is asynchronous to the crystal oscillator, the accuracy of re-starting the time circuits will be between zero and one 8.192 kHz cycle (see [Figure 11](#)).

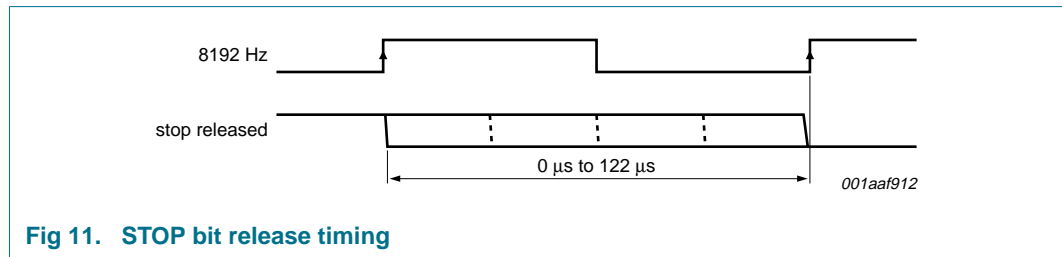

Fig 11. STOP bit release timing

Table 28. First increment of time circuits after STOP bit release

Bit	Prescaler bits	<a href="#">[1]</a>	1 Hz tick	Time	Comment
STOP	$F_0F_1F_2$ to $F_{14}$			hh:mm:ss	
<b>Clock is running normally</b>					
0	01-0	0001 1101 0100		12:45:12	prescaler counting normally
<b>STOP bit is activated by user. <math>F_0F_1</math> are not reset and values cannot be predicted externally</b>					
1	XX-0	0000 0000 0000		12:45:12	prescaler is reset; time circuits are frozen
<b>New time is set by user</b>					
1	XX-0	0000 0000 0000		08:00:00	prescaler is reset; time circuits are frozen
<b>STOP bit is released by user</b>					
0	XX-0	0000 0000 0000		08:00:00	prescaler is now running
	XX-1	0000 0000 0000		08:00:00	-
	XX-0	1000 0000 0000		08:00:00	-
	XX-1	1000 0000 0000		08:00:00	-
	:			:	:
	11-1	1111 1111 1110		08:00:00	-
	00-0	0000 0000 0001		08:00:01	0 to 1 transition of $F_{14}$ increments the time circuits
	10-0	0000 0000 0001		08:00:01	-
	:			:	:
	11-1	1111 1111 1111		08:00:01	-
	00-0	0000 0000 0000		08:00:01	-
	10-0	0000 0000 0000		08:00:01	-
	:			:	-
	11-1	1111 1111 1110		08:00:01	-
	00-0	0000 0000 0001		08:00:02	0 to 1 transition of $F_{14}$ increments the time circuits



[1]  $F_0$  is clocked at 32.768 kHz.

The first increment of the time circuits is between 0.507813 s and 0.507935 s after STOP bit is released. The uncertainty is caused by the prescaler bits  $F_0$  and  $F_1$  not being reset (see [Table 28](#)) and the unknown state of the 32 kHz clock.

### 9.13 Power-On Reset (POR) override

The POR duration is directly related to the crystal oscillator start-up time. Due to the long start-up times experienced by these types of circuits, a mechanism has been built in to disable the POR and hence speed up on-board test of the device. The setting of this mode requires that the I<sup>2</sup>C-bus pins, SDA and SCL, be toggled in a specific order as shown in [Figure 12](#). All timings are required minimums.

Once the override mode has been entered, the device immediately stops being reset and normal operation may commence i.e. entry into the EXT\_CLK test mode via I<sup>2</sup>C-bus access. The override mode may be cleared by writing a logic 0 to TESTC. TESTC must be set to logic 1 before re-entry into the override mode is possible. Setting TESTC to logic 0 during normal operation has no effect except to prevent entry into the POR override mode.

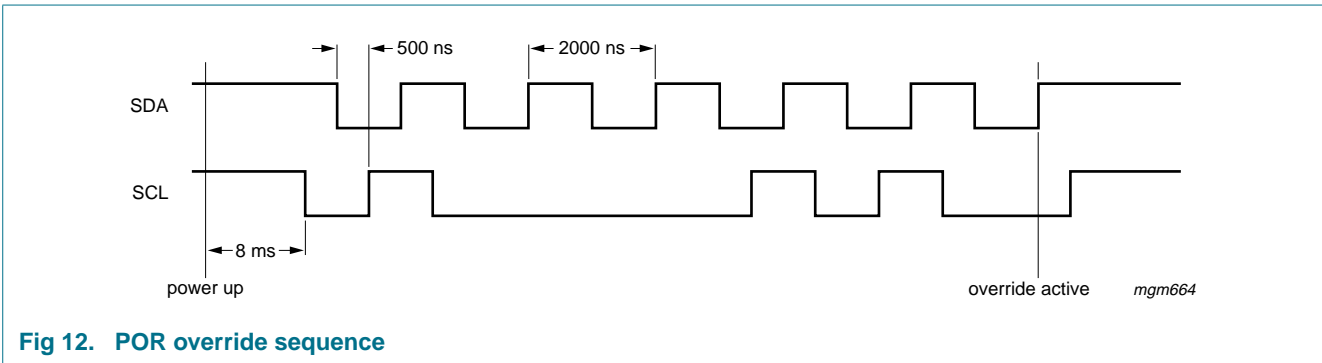

Fig 12. POR override sequence

## 10. Characteristics of the I<sup>2</sup>C-bus

The I<sup>2</sup>C-bus is for bidirectional, two-line communication between different ICs or modules. The two lines are a Serial Data Line (SDA) and a Serial Clock Line (SCL). Both lines must be connected to a positive supply via a pull-up resistor. Data transfer may be initiated only when the bus is not busy.

### 10.1 Bit transfer

One data bit is transferred during each clock pulse. The data on the SDA line must remain stable during the HIGH period of the clock pulse as changes in the data line at this time will be interpreted as a control signal (see [Figure 13](#)).

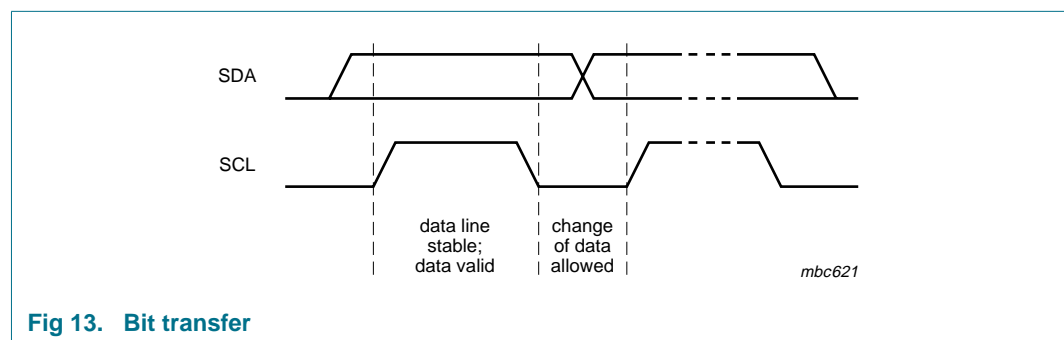

Fig 13. Bit transfer

### 10.2 START and STOP conditions

Both data and clock lines remain HIGH when the bus is not busy. A HIGH-to-LOW transition of the data line, while the clock is HIGH is defined as the START condition (S). A LOW-to-HIGH transition of the data line while the clock is HIGH is defined as the STOP condition (P), see [Figure 14](#).

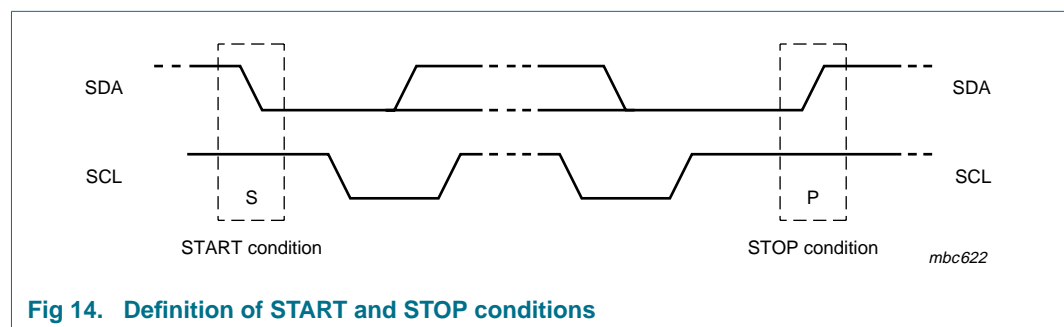

Fig 14. Definition of START and STOP conditions

### 10.3 System configuration

A device generating a message is a transmitter, a device receiving a message is the receiver. The device that controls the message is the master and the devices which are controlled by the master are the slaves (see [Figure 15](#)).

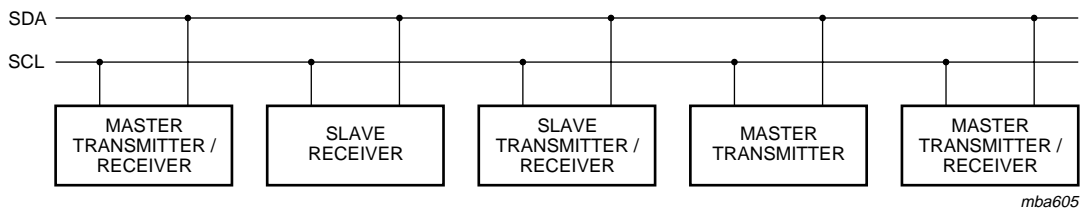

Fig 15. System configuration

### 10.4 Acknowledge

The number of data bytes transferred between the START and STOP conditions from transmitter to receiver is unlimited. Each byte of eight bits is followed by an acknowledge bit. The acknowledge bit is a HIGH-level signal put on the bus by the transmitter during which time the master generates an extra acknowledge related clock pulse. A slave receiver which is addressed must generate an acknowledge after the reception of each byte. Also a master receiver must generate an acknowledge after the reception of each byte that has been clocked out of the slave transmitter.

The device that acknowledges must pull down the SDA line during the acknowledge clock pulse, so that the SDA line is stable LOW during the HIGH period of the acknowledge related clock pulse (set-up and hold times must be taken into consideration). A master receiver must signal an end of data to the transmitter by not generating an acknowledge on the last byte that has been clocked out of the slave. In this event the transmitter must leave the data line HIGH to enable the master to generate a STOP condition.

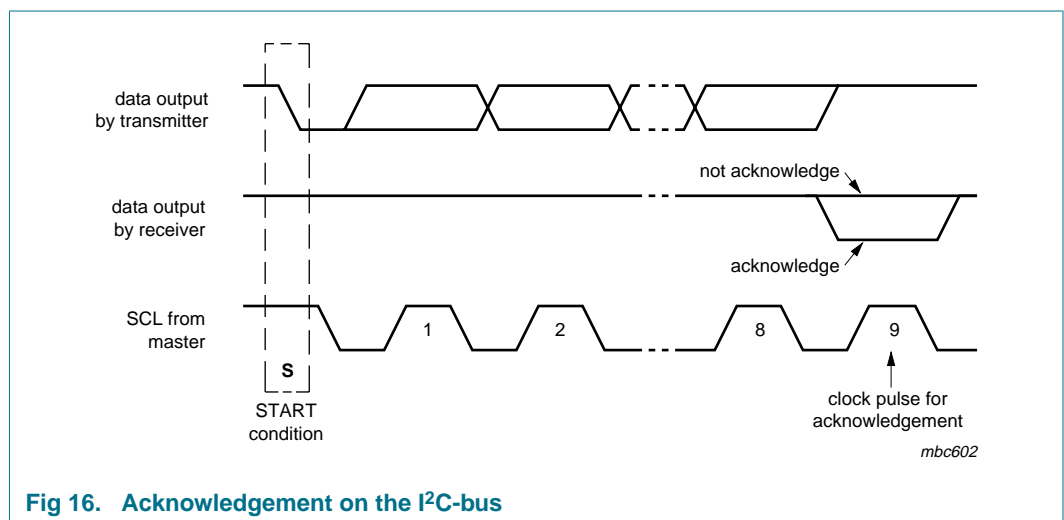

Fig 16. Acknowledgement on the I<sup>2</sup>C-bus

## 10.5 I<sup>2</sup>C-bus protocol

### 10.5.1 Addressing

Before any data is transmitted on the I<sup>2</sup>C-bus, the device which should respond is addressed first. The addressing is always carried out with the first byte transmitted after the start procedure.

The PCA8565 acts as a slave receiver or slave transmitter. Therefore the clock signal SCL is only an input signal, but the data signal SDA is a bidirectional line.

The PCA8565 slave address is shown in [Figure 17](#).

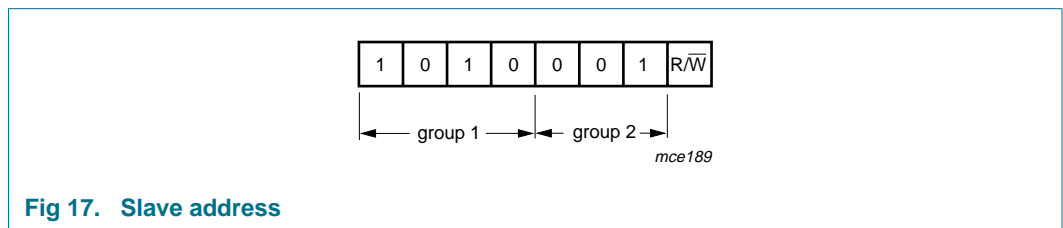

Fig 17. Slave address

### 10.5.2 Clock and calendar read/write cycles

The I<sup>2</sup>C-bus configuration for the different PCA8565 read and write cycles is shown in [Figure 18](#), [Figure 19](#) and [Figure 20](#). The word address is a 4-bit value that defines which register is to be accessed next. The upper four bits of the word address are not used.

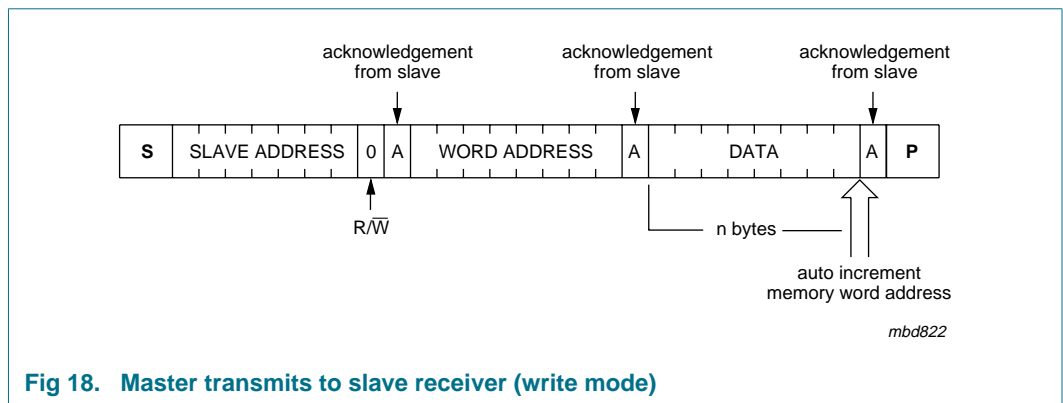

Fig 18. Master transmits to slave receiver (write mode)

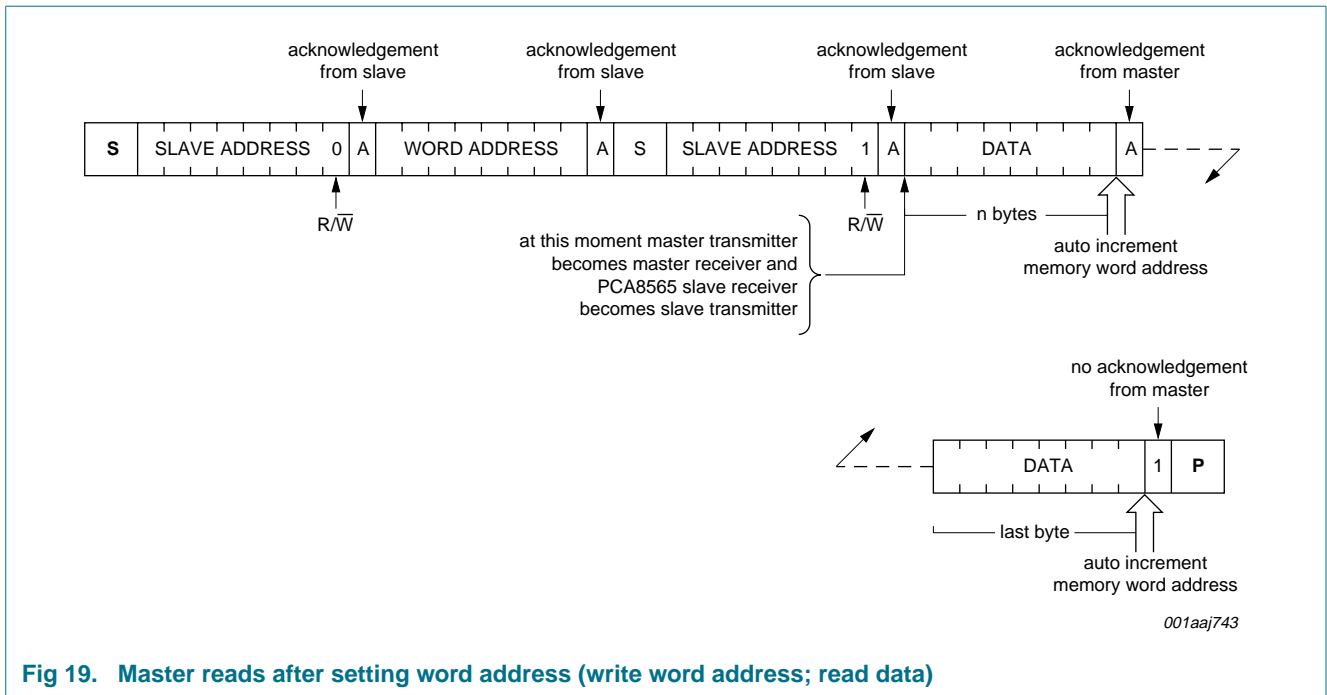

Fig 19. Master reads after setting word address (write word address; read data)

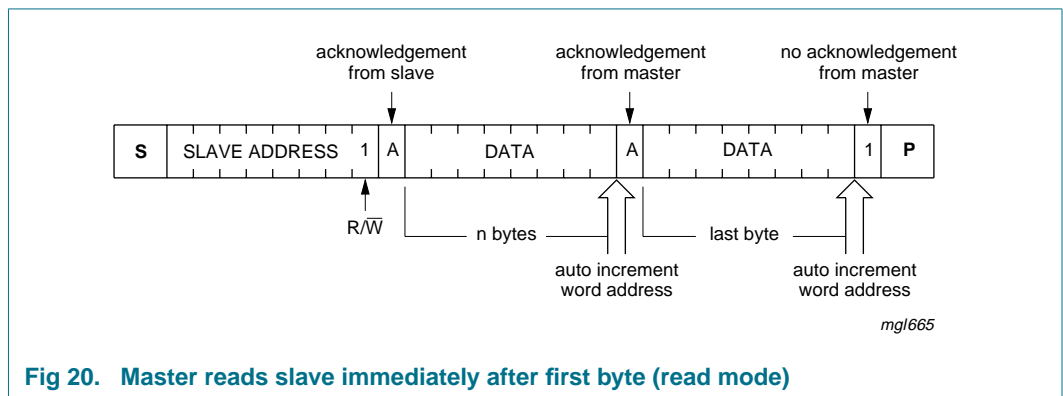

Fig 20. Master reads slave immediately after first byte (read mode)

### 10.5.3 Interface watchdog timer

During read/write operations, the time counting circuits are frozen. To prevent a situation where the accessing device becomes locked and does not clear the interface, the PCA8565 has a built in watchdog timer. Should the interface be active for more than 1 s from the time a valid slave address is transmitted, then the PCA8565 will automatically clear the interface and allow the time counting circuits to continue counting. Under a correct data transfer, the watchdog timer is stopped on receipt of a START or STOP condition.

The watchdog is implemented to prevent the excessive loss of time due to interface access failure e.g. if main power is removed from a battery backed-up system during an interface access.

Each time the watchdog period is exceeded, 1 s will be lost from the time counters. The watchdog will trigger between 1 s and 2 s after receiving a valid slave address.



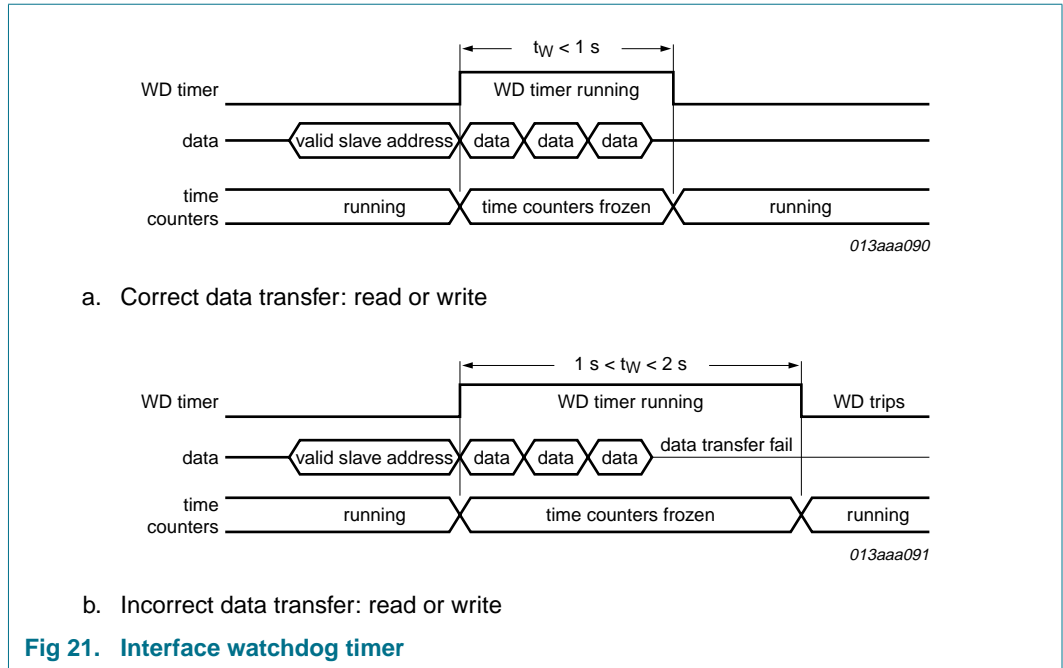

## 11. Limiting values

**Table 29. Limiting values**

*In accordance with the Absolute Maximum Rating System (IEC 60134).*

Symbol	Parameter	Conditions	Min	Max	Unit
$V_{DD}$	supply voltage		-0.5	+6.5	V
$I_{SS}$	ground supply current		-50	+50	mA
$I_{DD}$	supply current		-50	-50	mA
$V_I$	input voltage		-0.5	+6.5	V
$I_I$	input current		-10	+10	mA
$I_O$	output current		-10	+10	mA
$P_{tot}$	total power dissipation		-	300	mW
$T_{amb}$	ambient temperature		-40	+125	°C
$T_{stg}$	storage temperature		[1] -65	+150	°C
$V_{ESD}$	electrostatic discharge voltage	HBM	[2] -	±3000	V
		CDM	[3] -	±1100	V
$I_{lu}$	latch-up current		[4] -	250	mA

[1] According to the NXP store and transport conditions (document *SNW-SQ-623*) the devices have to be stored at a temperature of +5 °C to +45 °C and a humidity of 25 % to 75 %.

[2] Pass level; Human Body Model (HBM) according to JESD22-A114.

[3] Pass level; Charged-Device Model (CDM), according to JESD22-C101.

[4] Pass level; latch-up testing, according to JESD78.

## 12. Characteristics

### 12.1 Static characteristics

**Table 30. Static characteristics**

$V_{DD} = 1.8\text{ V to }5.5\text{ V}$ ;  $V_{SS} = 0\text{ V}$ ;  $T_{amb} = -40\text{ }^{\circ}\text{C to }+125\text{ }^{\circ}\text{C}$ ;  $f_{osc} = 32.768\text{ kHz}$ ; quartz  $R_s = 40\text{ k}\Omega$ ;  $C_L = 8\text{ pF}$ ; unless otherwise specified.

Symbol	Parameter	Conditions	Min	Typ	Max	Unit	
<b>Supplies</b>							
$V_{DD}$	supply voltage		1.8	-	5.5	V	
		for clock data integrity	$V_{low}$	-	5.5	V	
$V_{low}$	low voltage	for low voltage detection	-	0.9	1.7	V	
$I_{DD}$	supply current	interface active					
		$f_{SCL} = 400\text{ kHz}$	-	-	820	$\mu\text{A}$	
		$f_{SCL} = 100\text{ kHz}$	-	-	220	$\mu\text{A}$	
		interface inactive ( $f_{SCL} = 0\text{ Hz}$ ); $T_{amb} = 25\text{ }^{\circ}\text{C}$ [1]					
		CLKOUT disabled					
		$V_{DD} = 5.0\text{ V}$	-	750	1500	nA	
		$V_{DD} = 4.0\text{ V}$	-	700	1400	nA	
		$V_{DD} = 3.0\text{ V}$	-	650	1300	nA	
		$V_{DD} = 2.0\text{ V}$	-	600	1200	nA	
		$V_{DD} = 5.0\text{ V}$ ; $T_{amb} = 125\text{ }^{\circ}\text{C}$	[2] -	750	5000	nA	
		CLKOUT enabled at 32 kHz	[1]				
		$V_{DD} = 5.0\text{ V}$	-	1000	2000	nA	
		$V_{DD} = 4.0\text{ V}$	-	900	1800	nA	
$V_{DD} = 3.0\text{ V}$	-	800	1600	nA			
$V_{DD} = 2.0\text{ V}$	-	700	1400	nA			
$V_{DD} = 5.0\text{ V}$ ; $T_{amb} = 125\text{ }^{\circ}\text{C}$	[2] -	1000	6000	nA			
<b>Inputs</b>							
$V_{IL}$	LOW-level input voltage		$V_{SS} - 0.3$	-	$0.3V_{DD}$	V	
$V_{IH}$	HIGH-level input voltage	on pins SCL and SDA	$0.7V_{DD}$	-	5.5	V	
		on pin OSCI	$0.7V_{DD}$	-	$V_{DD} + 0.3$	V	
$I_{LI}$	input leakage current	on pins SCL and SDA; $V_I = V_{DD}$ or $V_{SS}$	-1	0	+1	$\mu\text{A}$	
$C_i$	input capacitance		[3] -	-	7	pF	
<b>Outputs</b>							
$I_{OL}$	LOW-level output current	$V_{OL} = 0.4\text{ V}$ ; $V_{DD} = 5\text{ V}$					
		on pin SDA	-3	-	-	mA	
		on pin $\overline{\text{INT}}$	-1	-	-	mA	
		$V_O = V_{DD}$ or $V_{SS}$ ; on pin CLKOUT	-1	-	-	mA	
$I_{LO}$	output leakage current		-1	0	+1	$\mu\text{A}$	

[1] Timer source clock =  $\frac{1}{60}$  Hz, level of pins SCL and SDA is  $V_{DD}$  or  $V_{SS}$ .

[2] Worst case is at high temperature and high supply voltage.

[3] Tested on sample basis.

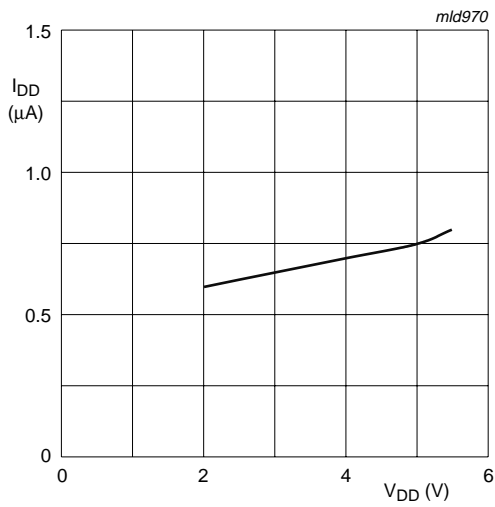

T<sub>amb</sub> = 25 °C; Timer = 1 minute; CLKOUT disabled.

Fig 22. I<sub>DD</sub> as a function of V<sub>DD</sub>

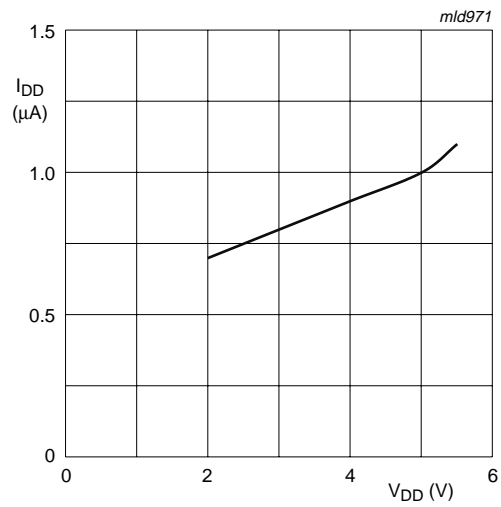

T<sub>amb</sub> = 25 °C; Timer = 1 minute; CLKOUT = 32 kHz.

Fig 23. I<sub>DD</sub> as a function of V<sub>DD</sub>

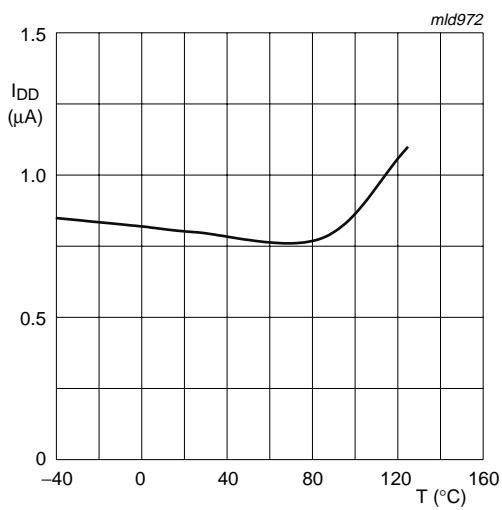

V<sub>DD</sub> = 3 V; Timer = 1 minute; CLKOUT = 32 kHz.

Fig 24. I<sub>DD</sub> as a function of temperature

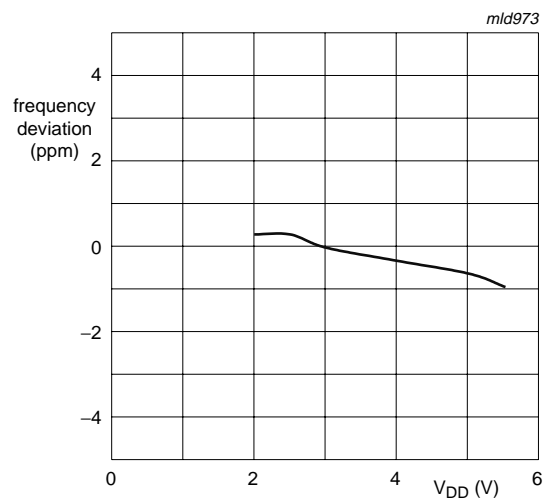

T<sub>amb</sub> = 25 °C; normalized to V<sub>DD</sub> = 3 V.

Fig 25. Frequency deviation as a function of V<sub>DD</sub>

## 12.2 Dynamic characteristics

**Table 31. Dynamic characteristics**

$V_{DD} = 1.8\text{ V to }5.5\text{ V}$ ;  $V_{SS} = 0\text{ V}$ ;  $T_{amb} = -40\text{ }^{\circ}\text{C to }+125\text{ }^{\circ}\text{C}$ ;  $f_{osc} = 32.768\text{ kHz}$ ; quartz  $R_s = 40\text{ k}\Omega$ ;  $C_L = 8\text{ pF}$ ; unless otherwise specified.

Symbol	Parameter	Conditions	Min	Typ	Max	Unit
<b>Oscillator</b>						
$C_{L(itg)}$	integrated load capacitance		[1] 15	25	35	pF
$\Delta f_{osc}/f_{osc}$	relative oscillator frequency variation	$\Delta V_{DD} = 200\text{ mV}$ ; $T_{amb} = 25\text{ }^{\circ}\text{C}$	-	$2 \times 10^{-7}$	-	ppm
<b>Quartz crystal parameters (f = 32.768 kHz)</b>						
$R_s$	series resistance		-	-	40	k $\Omega$
$C_L$	load capacitance		-	10	-	pF
$C_{trim}$	trimmer capacitance		5	-	25	pF
<b>CLKOUT output</b>						
$\delta_{CLKOUT}$	duty cycle on pin CLKOUT		[2] -	50	-	%
<b>I<sup>2</sup>C-bus timing characteristics</b>						
$f_{SCL}$	SCL clock frequency		[5] -	-	400	kHz
$t_{HD;STA}$	hold time (repeated) START condition		0.6	-	-	$\mu\text{s}$
$t_{SU;STA}$	set-up time for a repeated START condition		0.6	-	-	$\mu\text{s}$
$t_{LOW}$	LOW period of the SCL clock		1.3	-	-	$\mu\text{s}$
$t_{HIGH}$	HIGH period of the SCL clock		0.6	-	-	$\mu\text{s}$
$t_r$	rise time of both SDA and SCL signals		-	-	0.3	$\mu\text{s}$
$t_f$	fall time of both SDA and SCL signals		-	-	0.3	$\mu\text{s}$
$t_{SU;DAT}$	data set-up time		100	-	-	ns
$t_{HD;DAT}$	data hold time		0	-	-	ns
$t_{BUF}$	bus free time between a STOP and START condition		4.7	-	-	$\mu\text{s}$
$t_{SU;STO}$	set-up time for STOP condition		0.6	-	-	$\mu\text{s}$
$t_{SP}$	pulse width of spikes that must be suppressed by the input filter		-	-	50	ns
$C_b$	capacitive load for each bus line		-	-	400	pF

[1] Integrated load capacitance,  $C_{L(itg)}$ , is a calculation of  $C_{OSCI}$  and  $C_{OSCO}$  in series. 
$$C_{L(itg)} = \frac{(C_{OSCI} \cdot C_{OSCO})}{(C_{OSCI} + C_{OSCO})}$$

[2] For  $f_{CLKOUT} = 1.024\text{ kHz}$ ,  $32\text{ Hz}$  and  $1\text{ Hz}$ .

[3] All timing values are valid within the operating supply voltage at ambient temperature and referenced to  $V_{IL}$  and  $V_{IH}$  with an input voltage swing of  $V_{SS}$  to  $V_{DD}$ .

[4] A detailed description of the I<sup>2</sup>C-bus specification is given in the document *UM10204*.

[5] I<sup>2</sup>C-bus access time between two STARTs or between a START and a STOP condition to this device must be less than one second.

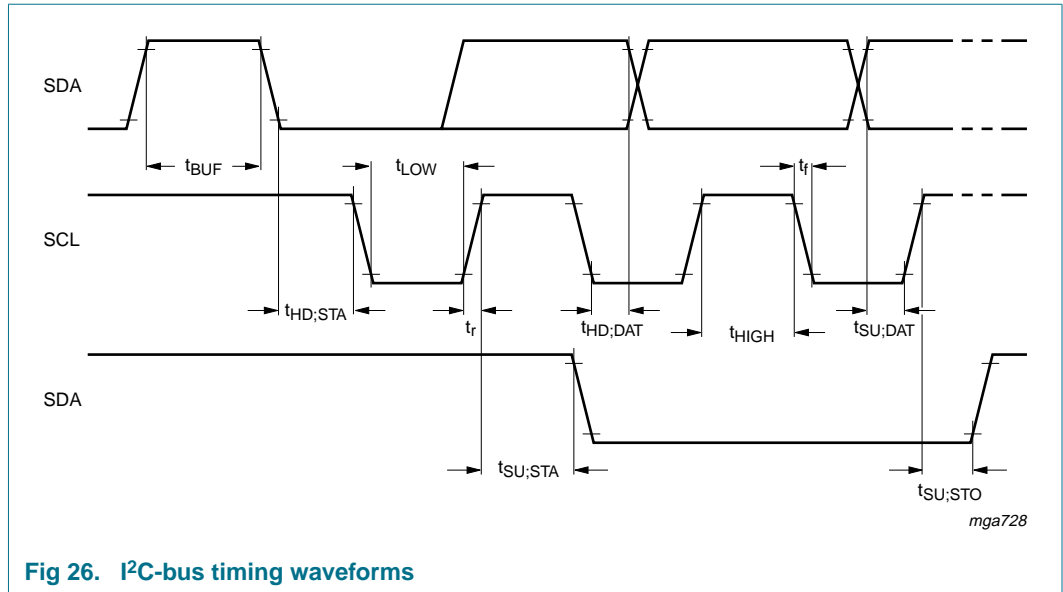

Fig 26. I<sup>2</sup>C-bus timing waveforms

### 13. Application information

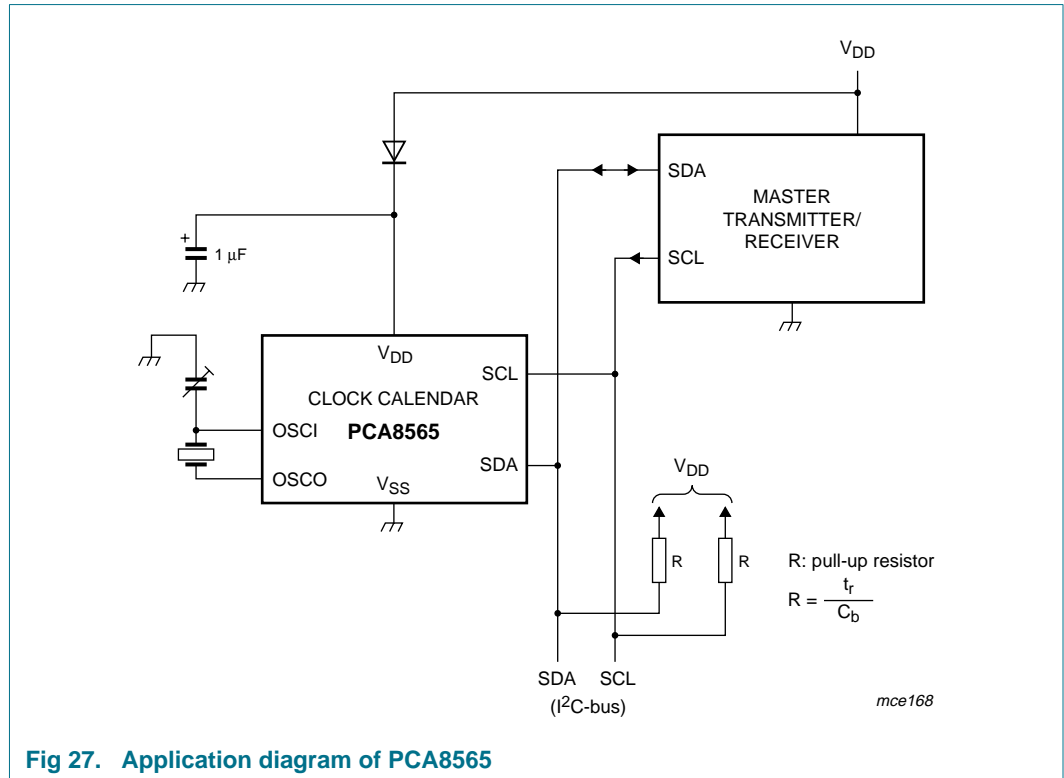

Fig 27. Application diagram of PCA8565

#### 13.1 Quartz frequency adjustment

##### 13.1.1 Method 1: fixed OSCI capacitor

By evaluating the average capacitance necessary for the application layout, a fixed capacitor can be used. The frequency is best measured via the 32.768 kHz signal available after power-on at pin CLKOUT. The frequency tolerance depends on the quartz crystal tolerance, the capacitor tolerance and the device-to-device tolerance (on average  $\Delta f/f = \pm 5 \times 10^{-6}$ ). Average deviations of  $\pm 5$  minutes per year can be easily achieved.

##### 13.1.2 Method 2: OSCI trimmer

Using the 32.768 kHz signal available after power-on at pin CLKOUT, fast setting of a trimmer is possible.

##### 13.1.3 Method 3: OSCO output

Direct measurement of OSCO out (allowing for test probe capacitance).

### 14. Package outline

TSSOP8: plastic thin shrink small outline package; 8 leads; body width 3 mm

SOT505-1

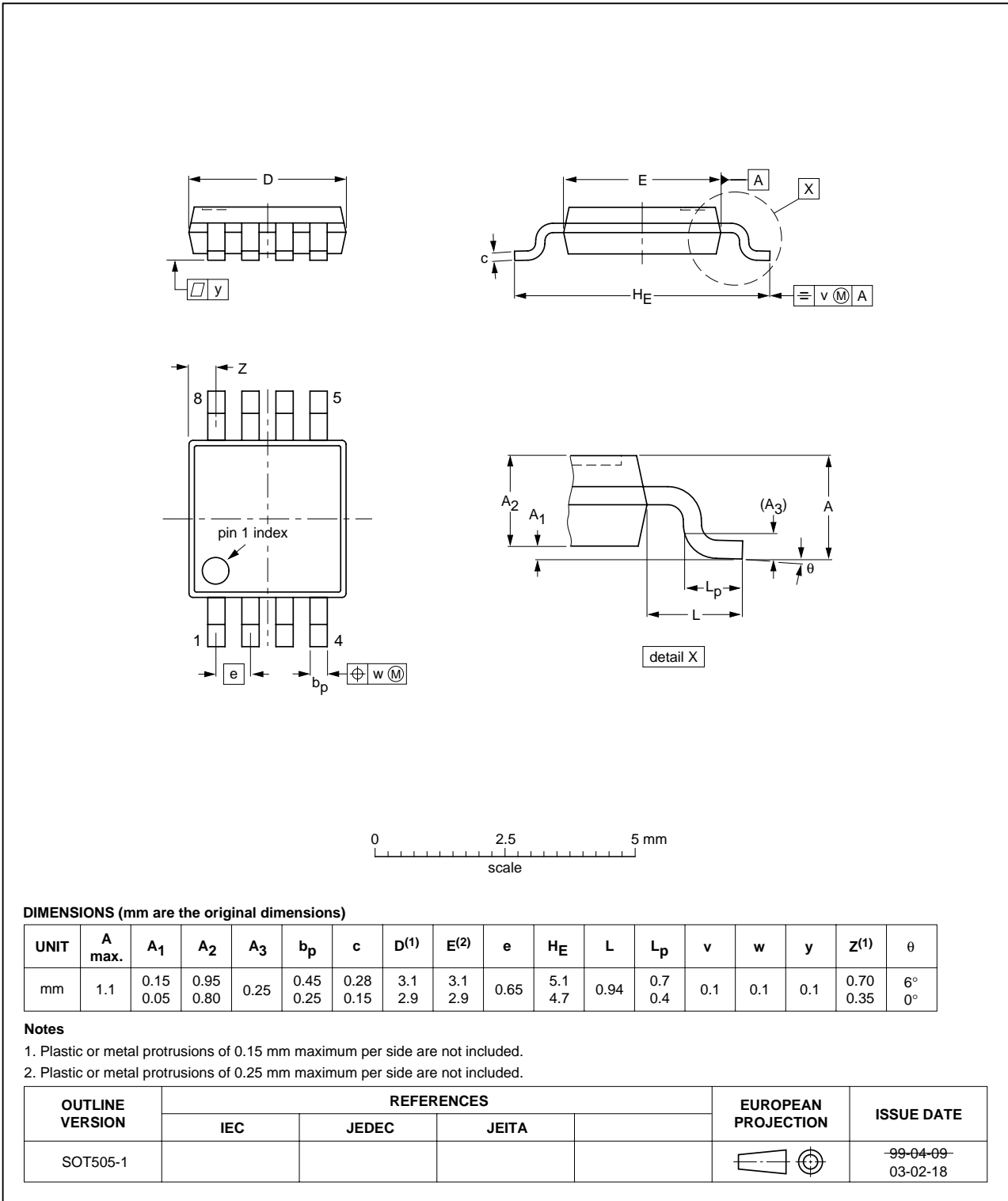
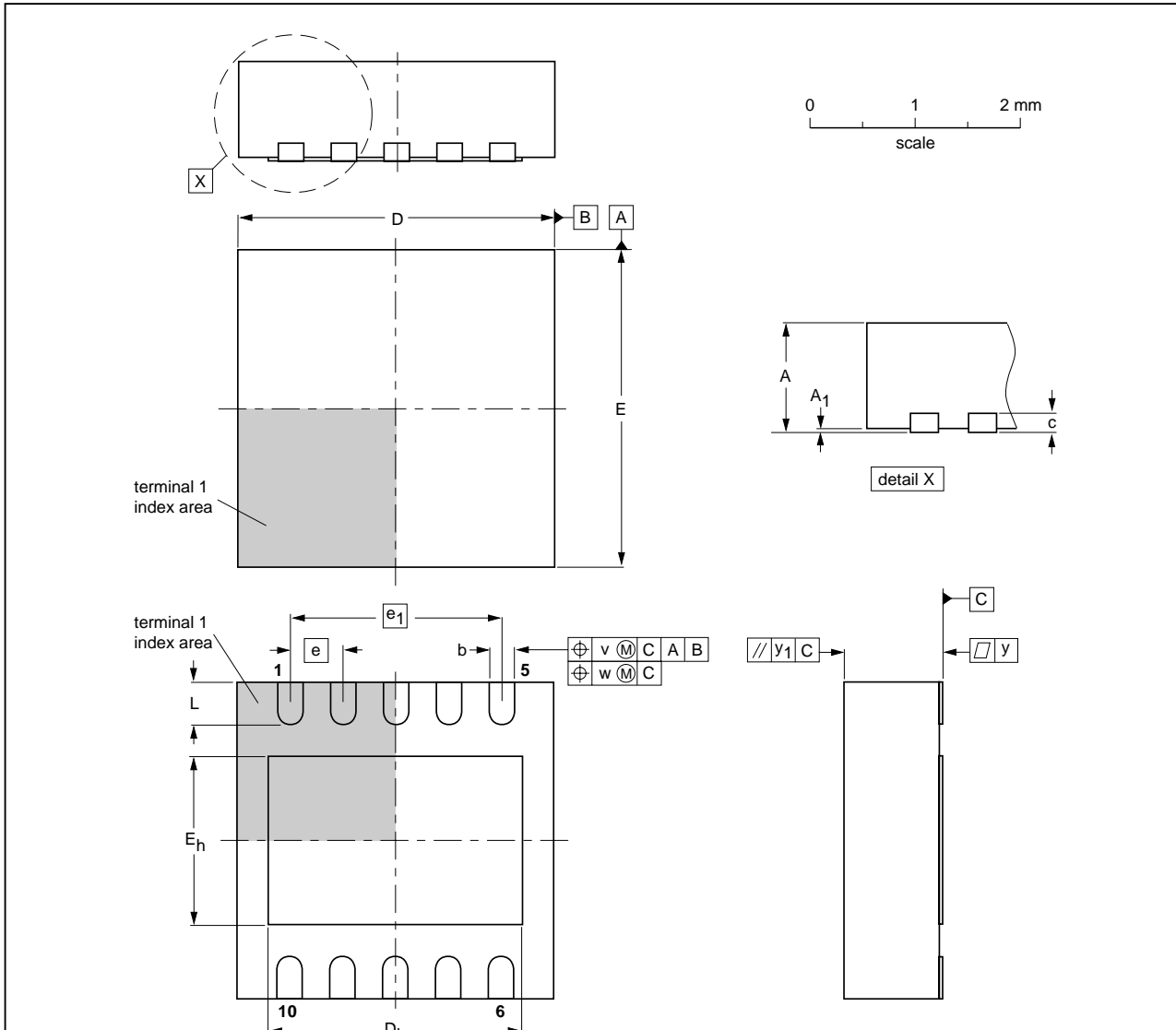

Fig 28. Package outline SOT505-1 (TSSOP8) of PCA8565TS



**HVSON10: plastic thermal enhanced very thin small outline package; no leads;  
10 terminals; body 3 x 3 x 0.85 mm**

**SOT650-1**



**DIMENSIONS (mm are the original dimensions)**

UNIT	A <sup>(1)</sup> max.	A <sub>1</sub>	b	c	D <sup>(1)</sup>	D <sub>h</sub>	E <sup>(1)</sup>	E <sub>h</sub>	e	e <sub>1</sub>	L	v	w	y	y <sub>1</sub>
mm	1	0.05 0.00	0.30 0.18	0.2	3.1 2.9	2.55 2.15	3.1 2.9	1.75 1.45	0.5	2	0.55 0.30	0.1	0.05	0.05	0.1

**Note**

1. Plastic or metal protrusions of 0.075 mm maximum per side are not included.

OUTLINE VERSION	REFERENCES				EUROPEAN PROJECTION	ISSUE DATE
	IEC	JEDEC	JEITA			
SOT650-1	---	MO-229	---			01-01-22- 02-02-08

**Fig 29. Package outline of SOT650-1 (HVSON10) of PCA8565BS**

## 15. Soldering of SMD packages

This text provides a very brief insight into a complex technology. A more in-depth account of soldering ICs can be found in Application Note *AN10365 "Surface mount reflow soldering description"*.

### 15.1 Introduction to soldering

Soldering is one of the most common methods through which packages are attached to Printed Circuit Boards (PCBs), to form electrical circuits. The soldered joint provides both the mechanical and the electrical connection. There is no single soldering method that is ideal for all IC packages. Wave soldering is often preferred when through-hole and Surface Mount Devices (SMDs) are mixed on one printed wiring board; however, it is not suitable for fine pitch SMDs. Reflow soldering is ideal for the small pitches and high densities that come with increased miniaturization.

### 15.2 Wave and reflow soldering

Wave soldering is a joining technology in which the joints are made by solder coming from a standing wave of liquid solder. The wave soldering process is suitable for the following:

- Through-hole components
- Leaded or leadless SMDs, which are glued to the surface of the printed circuit board

Not all SMDs can be wave soldered. Packages with solder balls, and some leadless packages which have solder lands underneath the body, cannot be wave soldered. Also, leaded SMDs with leads having a pitch smaller than ~0.6 mm cannot be wave soldered, due to an increased probability of bridging.

The reflow soldering process involves applying solder paste to a board, followed by component placement and exposure to a temperature profile. Leaded packages, packages with solder balls, and leadless packages are all reflow solderable.

Key characteristics in both wave and reflow soldering are:

- Board specifications, including the board finish, solder masks and vias
- Package footprints, including solder thieves and orientation
- The moisture sensitivity level of the packages
- Package placement
- Inspection and repair
- Lead-free soldering versus SnPb soldering

### 15.3 Wave soldering

Key characteristics in wave soldering are:

- Process issues, such as application of adhesive and flux, clinching of leads, board transport, the solder wave parameters, and the time during which components are exposed to the wave
- Solder bath specifications, including temperature and impurities

### 15.4 Reflow soldering

Key characteristics in reflow soldering are:

- Lead-free versus SnPb soldering; note that a lead-free reflow process usually leads to higher minimum peak temperatures (see [Figure 30](#)) than a SnPb process, thus reducing the process window
- Solder paste printing issues including smearing, release, and adjusting the process window for a mix of large and small components on one board
- Reflow temperature profile; this profile includes preheat, reflow (in which the board is heated to the peak temperature) and cooling down. It is imperative that the peak temperature is high enough for the solder to make reliable solder joints (a solder paste characteristic). In addition, the peak temperature must be low enough that the packages and/or boards are not damaged. The peak temperature of the package depends on package thickness and volume and is classified in accordance with [Table 32](#) and [33](#)

**Table 32. SnPb eutectic process (from J-STD-020C)**

Package thickness (mm)	Package reflow temperature (°C)	
	Volume (mm <sup>3</sup> )	
	< 350	≥ 350
< 2.5	235	220
≥ 2.5	220	220

**Table 33. Lead-free process (from J-STD-020C)**

Package thickness (mm)	Package reflow temperature (°C)		
	Volume (mm <sup>3</sup> )		
	< 350	350 to 2000	> 2000
< 1.6	260	260	260
1.6 to 2.5	260	250	245
> 2.5	250	245	245

Moisture sensitivity precautions, as indicated on the packing, must be respected at all times.

Studies have shown that small packages reach higher temperatures during reflow soldering, see [Figure 30](#).

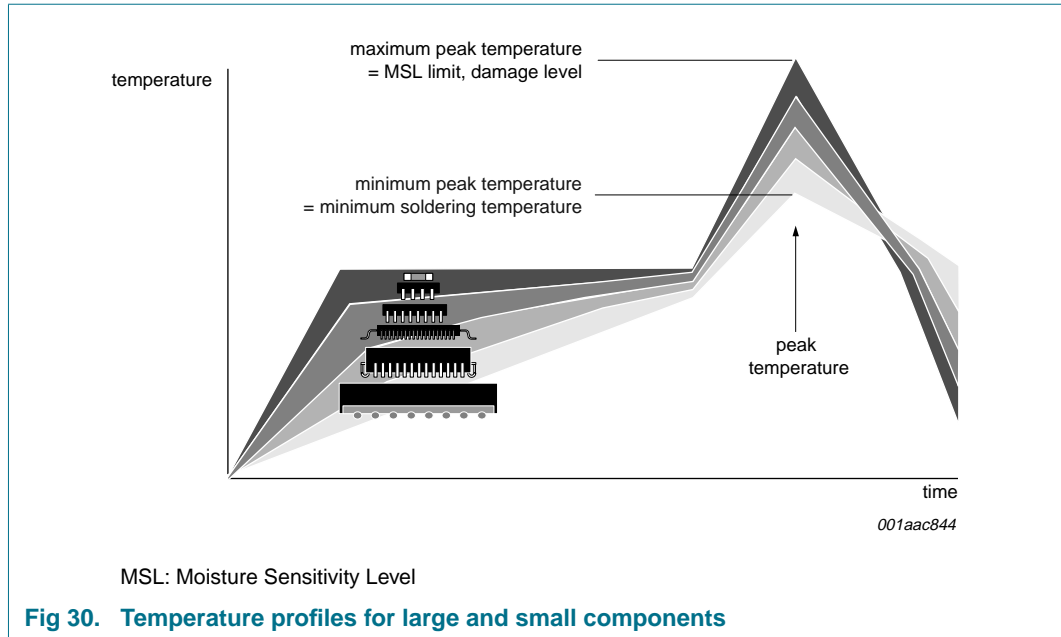

For further information on temperature profiles, refer to Application Note AN10365 “Surface mount reflow soldering description”.

## 16. Abbreviations

**Table 34. Abbreviations**

Acronym	Description
BCD	Binary Coded Decimal
CDM	Charged-Device Model
CMOS	Complementary Metal Oxide Semiconductor
HBM	Human Body Model
I <sup>2</sup> C	Inter-Integrated Circuit
IC	Integrated Circuit
MSB	Most Significant Bit
MSL	Moisture Sensitivity Level
PCB	Printed-Circuit Board
POR	Power-On Reset
RC	Resistance and Capacitance
RTC	Real Time Clock
SMD	Surface Mount Device

## 17. Revision history

**Table 35. Revision history**

Document ID	Release date	Data sheet status	Change notice	Supersedes
PCA8565_2	20090616	Product data sheet	-	PCA8565_1
Modifications		<ul style="list-style-type: none"> <li>• The format of this data sheet has been redesigned to comply with the new identity guidelines of NXP Semiconductors</li> <li>• Legal texts have been adapted to the new company name where appropriate</li> <li>• Added HVSON10 package</li> <li>• Added ESD and latch-up values</li> <li>• Changed values in limiting values table from relative to absolute values</li> <li>• Combined I<sub>DD1</sub> to I<sub>DD3</sub> values to one I<sub>DD</sub> value description with different conditions</li> <li>• Added automotive compliant statement</li> <li>• To gain a better understanding of the device               <ul style="list-style-type: none"> <li>– many parts of the data sheet have been rewritten</li> <li>– many new drawings have been added</li> </ul> </li> </ul>		
PCA8565_1	20030331	Product data	-	-

## 18. Legal information

### 18.1 Data sheet status

Document status <sup>[1][2]</sup>	Product status <sup>[3]</sup>	Definition
Objective [short] data sheet	Development	This document contains data from the objective specification for product development.
Preliminary [short] data sheet	Qualification	This document contains data from the preliminary specification.
Product [short] data sheet	Production	This document contains the product specification.

[1] Please consult the most recently issued document before initiating or completing a design.

[2] The term 'short data sheet' is explained in section "Definitions".

[3] The product status of device(s) described in this document may have changed since this document was published and may differ in case of multiple devices. The latest product status information is available on the Internet at URL <http://www.nxp.com>.

### 18.2 Definitions

**Draft** — The document is a draft version only. The content is still under internal review and subject to formal approval, which may result in modifications or additions. NXP Semiconductors does not give any representations or warranties as to the accuracy or completeness of information included herein and shall have no liability for the consequences of use of such information.

**Short data sheet** — A short data sheet is an extract from a full data sheet with the same product type number(s) and title. A short data sheet is intended for quick reference only and should not be relied upon to contain detailed and full information. For detailed and full information see the relevant full data sheet, which is available on request via the local NXP Semiconductors sales office. In case of any inconsistency or conflict with the short data sheet, the full data sheet shall prevail.

### 18.3 Disclaimers

**General** — Information in this document is believed to be accurate and reliable. However, NXP Semiconductors does not give any representations or warranties, expressed or implied, as to the accuracy or completeness of such information and shall have no liability for the consequences of use of such information.

**Right to make changes** — NXP Semiconductors reserves the right to make changes to information published in this document, including without limitation specifications and product descriptions, at any time and without notice. This document supersedes and replaces all information supplied prior to the publication hereof.

**Suitability for use** — NXP Semiconductors products are not designed, authorized or warranted to be suitable for use in medical, military, aircraft, space or life support equipment, nor in applications where failure or malfunction of an NXP Semiconductors product can reasonably be expected to result in personal injury, death or severe property or environmental

damage. NXP Semiconductors accepts no liability for inclusion and/or use of NXP Semiconductors products in such equipment or applications and therefore such inclusion and/or use is at the customer's own risk.

**Applications** — Applications that are described herein for any of these products are for illustrative purposes only. NXP Semiconductors makes no representation or warranty that such applications will be suitable for the specified use without further testing or modification.

**Limiting values** — Stress above one or more limiting values (as defined in the Absolute Maximum Ratings System of IEC 60134) may cause permanent damage to the device. Limiting values are stress ratings only and operation of the device at these or any other conditions above those given in the Characteristics sections of this document is not implied. Exposure to limiting values for extended periods may affect device reliability.

**Terms and conditions of sale** — NXP Semiconductors products are sold subject to the general terms and conditions of commercial sale, as published at <http://www.nxp.com/profile/terms>, including those pertaining to warranty, intellectual property rights infringement and limitation of liability, unless explicitly otherwise agreed to in writing by NXP Semiconductors. In case of any inconsistency or conflict between information in this document and such terms and conditions, the latter will prevail.

**No offer to sell or license** — Nothing in this document may be interpreted or construed as an offer to sell products that is open for acceptance or the grant, conveyance or implication of any license under any copyrights, patents or other industrial or intellectual property rights.

**Export control** — This document as well as the item(s) described herein may be subject to export control regulations. Export might require a prior authorization from national authorities.

### 18.4 Trademarks

Notice: All referenced brands, product names, service names and trademarks are the property of their respective owners.

**I<sup>2</sup>C-bus** — logo is a trademark of NXP B.V.

## 19. Contact information

For more information, please visit: <http://www.nxp.com>

For sales office addresses, please send an email to: [salesaddresses@nxp.com](mailto:salesaddresses@nxp.com)

20. Contents

<b>1</b>	<b>General description</b> . . . . .	<b>1</b>	<b>13</b>	<b>Application information</b> . . . . .	<b>31</b>
<b>2</b>	<b>Features</b> . . . . .	<b>1</b>	13.1	Quartz frequency adjustment . . . . .	31
<b>3</b>	<b>Applications</b> . . . . .	<b>1</b>	13.1.1	Method 1: fixed OSC1 capacitor . . . . .	31
<b>4</b>	<b>Ordering information</b> . . . . .	<b>2</b>	13.1.2	Method 2: OSC1 trimmer . . . . .	31
<b>5</b>	<b>Marking</b> . . . . .	<b>2</b>	13.1.3	Method 3: OSCO output . . . . .	31
<b>6</b>	<b>Block diagram</b> . . . . .	<b>3</b>	<b>14</b>	<b>Package outline</b> . . . . .	<b>32</b>
<b>7</b>	<b>Pinning information</b> . . . . .	<b>4</b>	<b>15</b>	<b>Soldering of SMD packages</b> . . . . .	<b>34</b>
7.1	Pinning . . . . .	4	15.1	Introduction to soldering . . . . .	34
7.2	Pin description . . . . .	4	15.2	Wave and reflow soldering . . . . .	34
<b>8</b>	<b>Device protection diagram</b> . . . . .	<b>5</b>	15.3	Wave soldering . . . . .	34
<b>9</b>	<b>Functional description</b> . . . . .	<b>5</b>	15.4	Reflow soldering . . . . .	35
9.1	Register overview . . . . .	6	<b>16</b>	<b>Abbreviations</b> . . . . .	<b>36</b>
9.2	Control registers . . . . .	7	<b>17</b>	<b>Revision history</b> . . . . .	<b>37</b>
9.2.1	Register Control_1 . . . . .	7	<b>18</b>	<b>Legal information</b> . . . . .	<b>38</b>
9.2.2	Register Control_2 . . . . .	7	18.1	Data sheet status . . . . .	38
9.3	Reset . . . . .	8	18.2	Definitions . . . . .	38
9.4	Time and date registers . . . . .	8	18.3	Disclaimers . . . . .	38
9.5	Data flow . . . . .	11	18.4	Trademarks . . . . .	38
9.6	Alarm function . . . . .	12	<b>19</b>	<b>Contact information</b> . . . . .	<b>38</b>
9.6.1	Alarm registers . . . . .	13	<b>20</b>	<b>Contents</b> . . . . .	<b>39</b>
9.6.2	Alarm flag . . . . .	13			
9.7	Timer functions . . . . .	14			
9.7.1	Register Timer_control . . . . .	15			
9.8	Interrupt output . . . . .	15			
9.8.1	Bits TF and AF . . . . .	15			
9.8.2	Bits TIE and AIE . . . . .	16			
9.8.3	Countdown timer interrupts . . . . .	16			
9.9	Clock output . . . . .	16			
9.10	Voltage-low detector . . . . .	17			
9.11	External clock (EXT_CLK) test mode . . . . .	17			
9.12	STOP bit function . . . . .	18			
9.13	Power-On Reset (POR) override . . . . .	20			
<b>10</b>	<b>Characteristics of the I<sup>2</sup>C-bus</b> . . . . .	<b>21</b>			
10.1	Bit transfer . . . . .	21			
10.2	START and STOP conditions . . . . .	21			
10.3	System configuration . . . . .	21			
10.4	Acknowledge . . . . .	22			
10.5	I <sup>2</sup> C-bus protocol . . . . .	23			
10.5.1	Addressing . . . . .	23			
10.5.2	Clock and calendar read/write cycles . . . . .	23			
10.5.3	Interface watchdog timer . . . . .	24			
<b>11</b>	<b>Limiting values</b> . . . . .	<b>26</b>			
<b>12</b>	<b>Characteristics</b> . . . . .	<b>27</b>			
12.1	Static characteristics . . . . .	27			
12.2	Dynamic characteristics . . . . .	29			

Please be aware that important notices concerning this document and the product(s) described herein, have been included in section 'Legal information'.

