

Typical Circuit Applications

(1) PLL Spindle Motor Drive Circuit for 3.5-inch HDDs

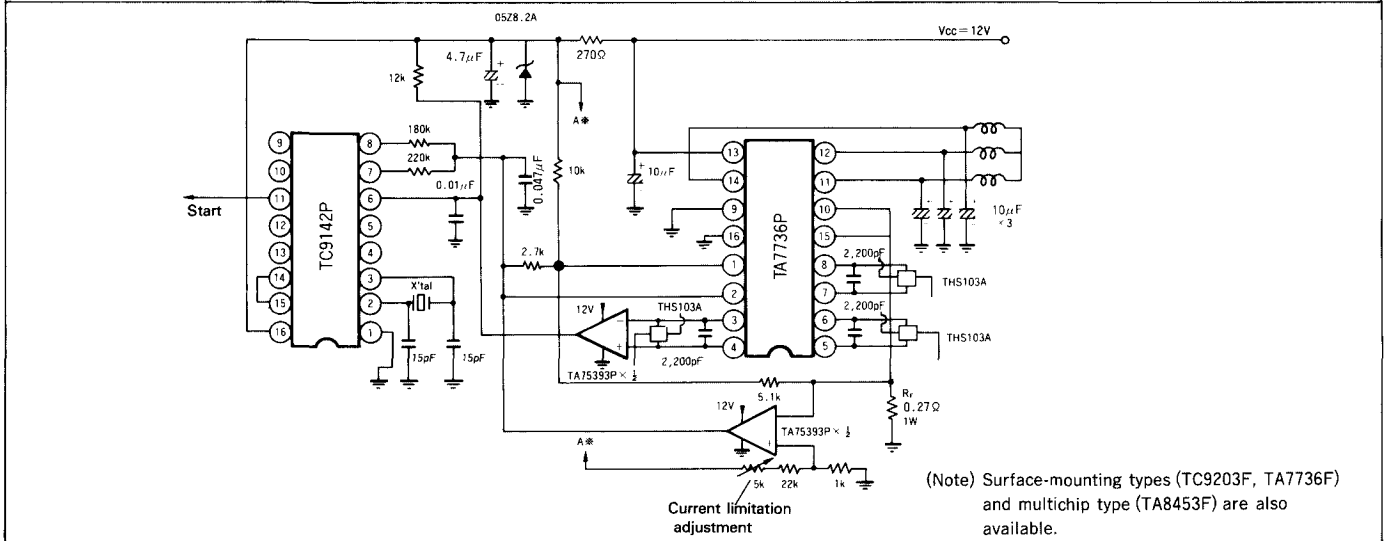

(2) Stepping Motor Drive Circuit for Driving Heads for 5.25-inch and 3.5-inch FDDs

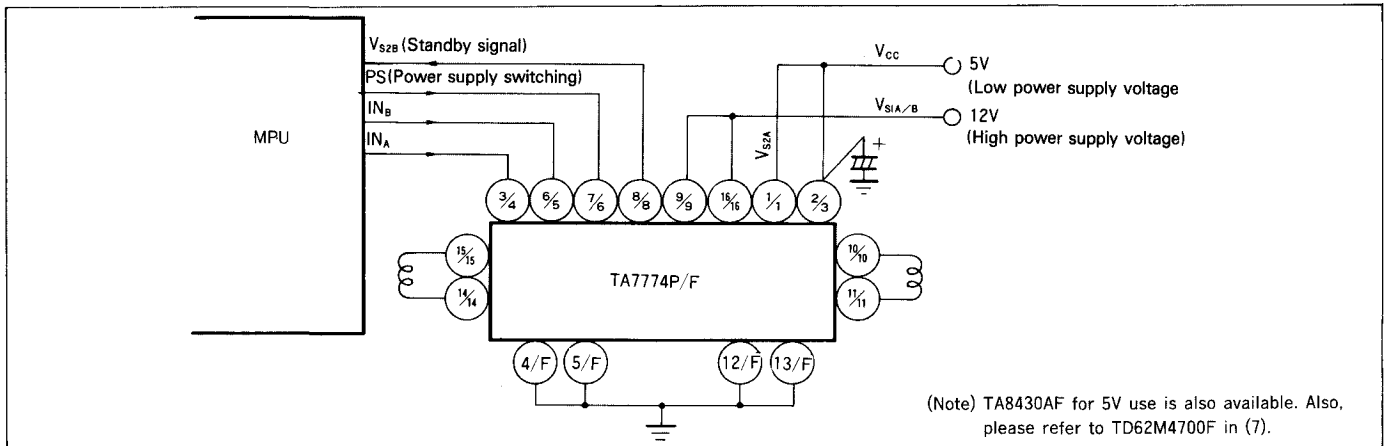

(3) High-Speed Carriage Motor Drive Circuit for PPCs and Printers (Stepping Motor)

