

GENERAL DESCRIPTION:

Amphenol's line of D-Subminiature rack and panel connectors is part of an industry standard for applications requiring reliable, rugged, connectors. These connectors are designed to accommodate rack and panel, cable to panel and cable to cable applications. D-Subminiature connectors are pin and socket devices that employ contacts encased in a molded dielectric insert surrounded by a "D" shaped shell for polarization.

MARKETS:

Amphenol D-Subminiature connectors can be used in commercial, industrial or military markets. We offer a broad selection of dielectric materials and contact styles and configurations to meet all of your design requirements.

APPLICATIONS INCLUDE:

- Business equipment
- Electronic office systems
- Data communications
- Medical equipment
- Mobile communications
- Consumer electronics

AMPHENOL D-SUB FEATURES:

- Industry standard interfacing RS232 and RS449 mating configurations per EIA standards.
- UL Component Recognition File number E64911 (617, 841, 17, 17D, 17HD, ED, 17RR, 17SD, 117DF, 17BH, 17TW)
- Variations available:
 - Solder cup
 - Straight pc mount solder
 - Right angle pc mount solder
 - Solderless wire wrap
 - Crimp
 - High Density Right Angle
 - High Density Straight
 - Stacked Right Angle PC mount
 - Surface mount
- Five shell sizes offer widest choice of contact positions: 9, 15, 25, 37 and 50 in standard density and 15, 26, 44, 62 and 78 positions in high-density.
- Inserts are flame-retardant thermoplastic.
- Accessories for all applications are available including strain reliefs, cable clamps, shielded backshells, mating hardware and connector to pc board mounting hardware.
- Automatic and manual tooling is available for both crimp and IDC versions.
- Contact Amphenol for lease information.

Fixed Machined Contact Connector

- Standards:
- UL File: E119881
 - Connectors according to MIL C24308

SPECIFICATIONS:

MATERIALS AND PLATINGS

| | |
|----------------------------|---|
| Shells | Steel yellow chromated over zinc or tinned steel with or without dimples on plug connector |
| Insulator | Glass-filled thermoplastic, UL 94V-0 |
| Rear Insert | Brass, 118µ" up to 197µ" (3µm up to 5µm) tinned over nickel 78µ" up to 118µ" (2µm up to 3µm) |
| Boardlock | Tin-lead plating 157µ" up to 236µ" (4µm up to 6µm) over nickel 78µ" up to 118µ" (2µm up to 3µm) |
| Screwlock | Brass, 236µ" up to 394µ" (6µm up to 10µm) tinned over nickel 78µ" up to 118µ" (2µm up to 3µm) |
| Contacts | D: brass DF: pin = brass Socket = copper alloy |
| Right Angle Version | Selective gold in mating area over 78µ" up to 118µ" (2µm up to 3µm) nickel; 118µ" up to 197µ" (3µm up to 5µm) tin-lead on termination area over 78µ" up to 118µ" (2µm up to 3µm) nickel |
| Straight Version | Full gold plating over 78µ" up to 118µ" (2µm up to 3µm) nickel |

ELECTRICAL DATA

| | |
|------------------------------|----------------------------------|
| Current Rating | 7.5 A |
| Voltage Rating | 300 V AC/rms 50Hz |
| Withstanding Voltage | 1000V AC/rms 50Hz for one minute |
| Insulation Resistance | 5000MΩ |
| Contact Resistance | D: 8.5mΩ max. DF: 5mΩ max. |

CLIMATIC DATA

| | |
|------------------------------|--|
| Operating Temperature | D: -67°F (-55°C) to +185°F (85°C), peak at 257°F (125°C) DF: -67°F (-55°C) to + 257°F (125°C) |
|------------------------------|--|

MECHANICAL DATA

| No. of Contacts | Mate (max.) | Unmate (min.) |
|-----------------|---------------|---------------|
| 9 (size E) | 6.74 (3.05) | 0.79 (0.36) |
| 15 (size A) | 11.24 (5.09) | 1.01 (0.46) |
| 25 (size B) | 18.66 (8.44) | 1.8 (0.81) |
| 37 (size C) | 27.65 (12.51) | 2.47 (1.1) |
| 50 (size D) | 32.38 (14.65) | 3.56 (1.6) |

INCHES (MM)

D-DF SERIES

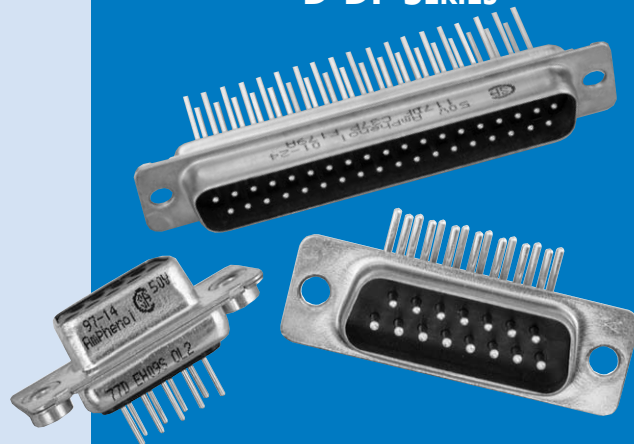

The Amphenol SD series features precision formed contacts, and 4 finger boardlocks.

This series gives you Amphenol's high standards of quality and reliability to meet all of your commercial requirements.

- Industrial
- Telecom
- Any industry standard I / O connections

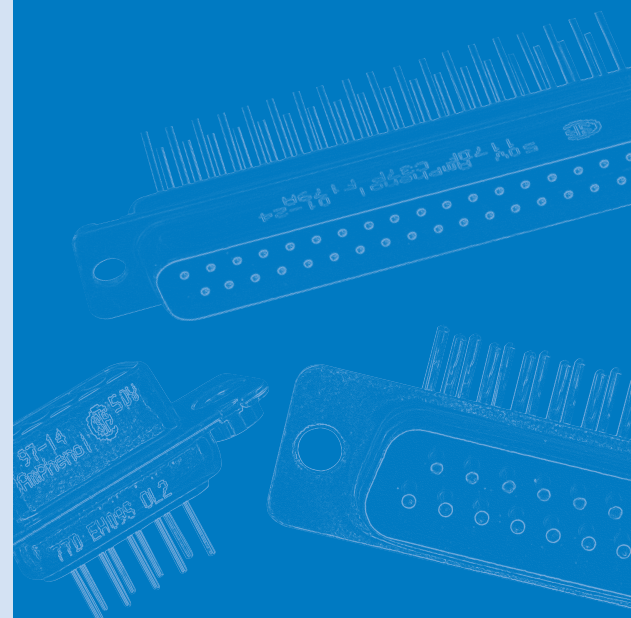

Solder cup

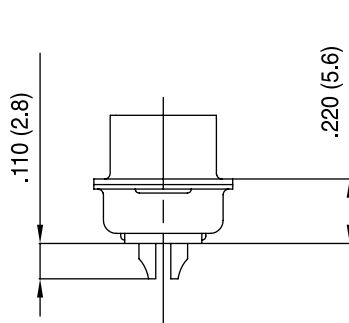

Wire Wrap

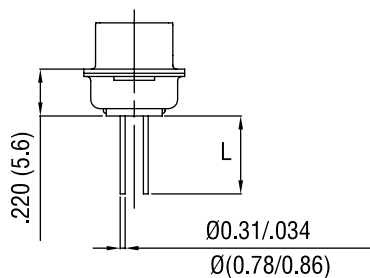

| Termination | Nb of wraps | L |
|-------------|-------------|------------|
| F179 | 2 | .378 (9.6) |
| F179A | 3 | .512 (13) |

Straight PCB

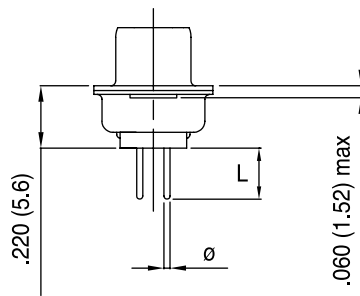

| Termination | Ø | L |
|-------------|-------------|------------|
| U | .024 (0.6) | .126 (3.2) |
| V | .040 (1.02) | .095 (2.4) |
| T | .024 (0.6) | .157 (4) |
| OL2 | .02 (0.6) | .217 (5.5) |

Grounding tabs

For straight termination

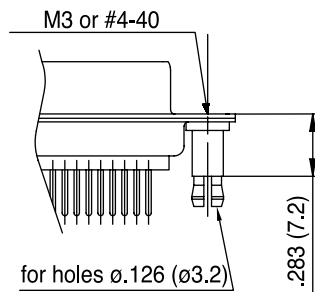

RM5

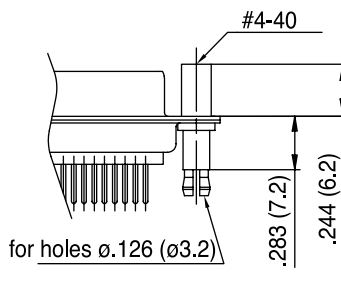

RM8

For R/A termination

FOR PCB .062 (1.6)

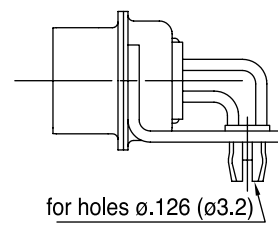

RM6

ORDERING INFORMATION

XXXXX X X XX X XXXXX XXXX X

| | |
|------------------|--|
| 8µ" (0.2µm) | 17D: yellow chromated shell 77D: tinned shell for receptacle 717D: tinned shell + dimples for plug |
| 20µ" (0.5µm) | 17DF: yellow chromated shell 77DF: tinned shell for receptacle 717DF: tinned shell + dimples for plug |
| 30µ" (0.76µm) | 117DF: yellow chromated shell 177DF: tinned shell for receptacle 777DF: tinned shell + dimples for plug |

For specific product

Grounding tabs:

- RM5 for straight PCB mounting*
- RM8 for straight PCB mounting + female lock
- RM6 for right angle PCB mounting
- VF front screwlock 4-40
- VFM front screwlock M3
- VF2 removable screwlock 4-40
- VF2M removable screwlock M3

Termination:

solder cup: no digit

Wire Wrap:

- F179 length .378 (9.6)
- F179A length .512 (13)

Straight PCB:

- U length .126 (3.2) tail ø.024 (ø0.6)
- V length .094 (2.4) tail ø.040 (ø1.02)
- T length .157 (4) tail ø.024 (ø0.6)
- OL2 length .216 (5.5) tail ø.024 (ø0.6)

Right Angle Connector:

- MIL footprint
- without bracket: C tail ø.040 (ø1.02)
 - A4 tail ø.024 (ø0.6)
 - plastic bracket: AJ3 tail ø.040 (ø1.02)
 - AJ4 tail ø.024 (ø0.6)
 - metal bracket: A tail ø.040 (ø1.02)
 - AM4 A ø.519 (13.2)
 - AZ4 A ø.453 (11.5)
 - AM4B footprint ø.590 (14.99)

European footprint

- without bracket: 1AON X .100 (2.54)
- 1BON X .112 (2.84)
- plastic bracket: 1APN X .100 (2.54)
- 1BPN X .112 (2.84)
- 1AUN X .100 (2.54)
- 1BUN X .112 (2.84)
- metal bracket: 1AMN X .100 (2.54)
- 1BMN X .112 (2.84)
- 1ATN X .100 (2.54)
- 1BTN X .112 (2.84)

Shell size: E, A, B, C, D

Mounting Options:

- H rear insert 4-40
- G rear insert M3
- F float mounting
- no digit standard rivet .122 (ø 3.1)
- *H, G must also be used to specify the threading of RM5 grounding tabs.

Configuration: 09, 15, 25, 37, 50

Contact type:

- P pin
- S socket

Standard options

For special request, please consult factory

For Filtered D-Sub, see page 56.

17D-80

DATE DU TIRAGE

N ETUDE

N OUTIL

N CLIENT

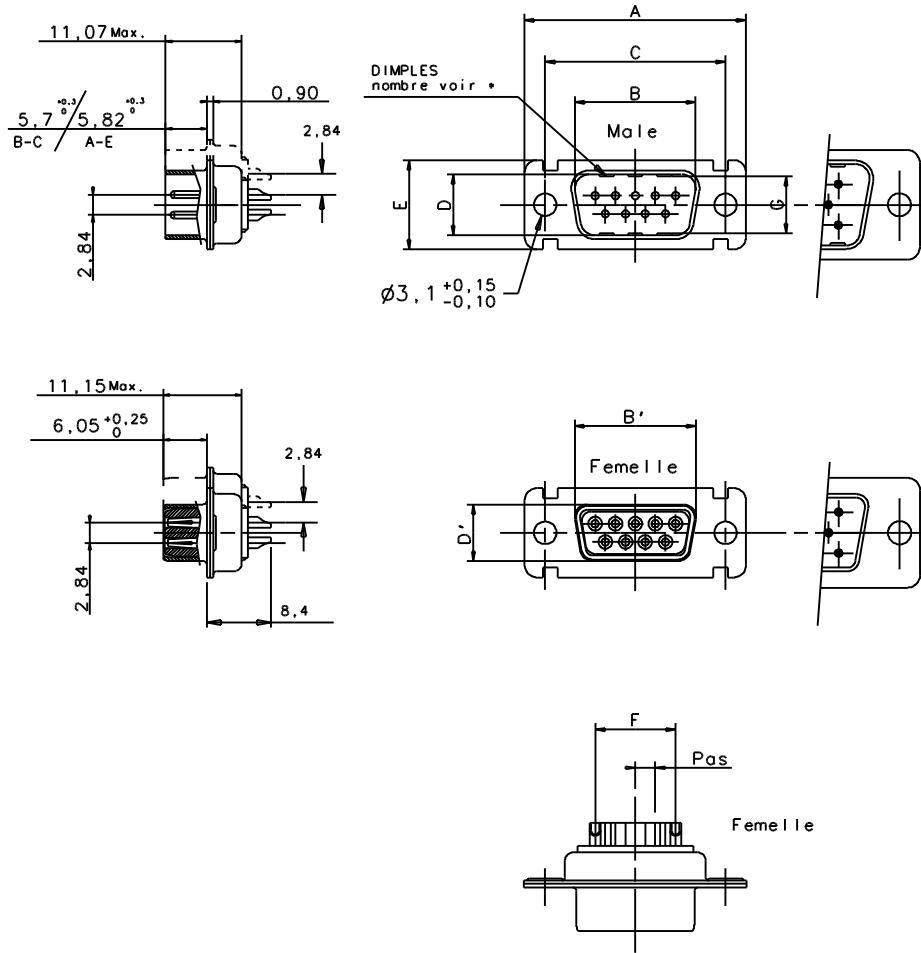

| Taille boîtier | A | B' | B | C | D' | D | E | F ±0,05 | Pas | G | * |
|----------------|-------|-------|-------|-------|-------|-------|-------|---------|------|------|------|
| E | 11,07 | 11,15 | 11,15 | 11,15 | 11,15 | 11,15 | 11,15 | 11,15 | 2,74 | 7,62 | 2x3 |
| A | 19,20 | 19,20 | 19,20 | 19,20 | 19,20 | 19,20 | 19,20 | 19,20 | 2,74 | 7,62 | 2x5 |
| B | 33,12 | 33,12 | 33,12 | 33,12 | 33,12 | 33,12 | 33,12 | 33,12 | 2,76 | 7,62 | 2x8 |
| C | 49,68 | 49,68 | 49,68 | 49,68 | 49,68 | 49,68 | 49,68 | 49,68 | 2,76 | 7,62 | 2x12 |
| D | 44,20 | 44,20 | 44,20 | 44,20 | 44,20 | 44,20 | 44,20 | 44,20 | 2,76 | 10,5 | 2x12 |

TECHNICAL DATA

'' D '' SUBMINIATURE CONNECTORS

SHELL : Material : Steel
Plating : 100µ" Tin over 78µ" Nickel

BODY : Glass filled thermoplastic
Flame retardant to UL 94 V-0
Colour : black

CONTACTS Material for sockets : Brass
Material for pins : Brass
Plating of mating area : 8µ" Gold over 78µ" Nickel

ELECTRICAL Voltage rating 300 V Rms to 50Hz
Nominal current 7.5 A (size20)
Voltage proof >1000 V Rms to 50 Hz
Contact resistance <8.5m Ohms
Insulator resistance >5000 M Ohms

CLIMATIC Temperature range -55°C +85°C
Damp heart 21 days (40°C - 95 % RH)

MECHANICAL Insertion force per contact 1,2N < F <2,5 N
Extraction force per contact 0,4 N mini
Mating and unmating force size E 30N maxi 3.5N mini
A 50N maxi 4.5N mini
B 83N maxi 8.0N mini
C 123N maxi 11N mini
D 166N maxi 14.5N mini

(With or without dimples)

MARKING Amphenol - ... (serie number)
Commercial reference
Manufacturing date

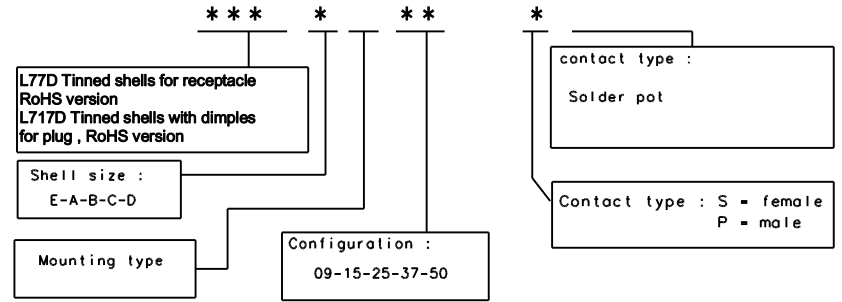

Amphenol Socapex
Usine de Dole

ECHELLE: 1:5

Creation plan 14/01 98
IND. MODIFICATION DATE Execu/Approv

PLAN NOTICE

N SERIE 017F

DESIGNATION a souder / solder pot

17D++++

COMMUNICATION ET UTILISATION INTERDITES SAUF AUTORISATION

17D-80

DATE DU TIRAGE

N ETUDE

N OUTIL

N CLIENT

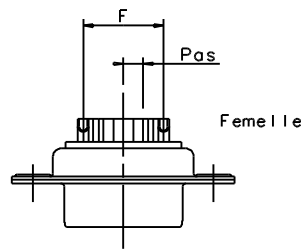
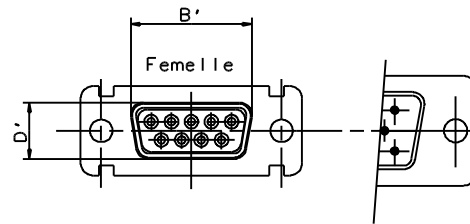
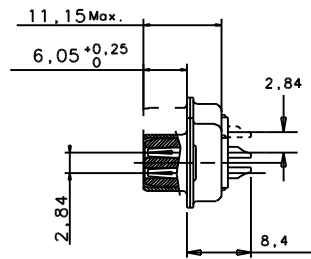
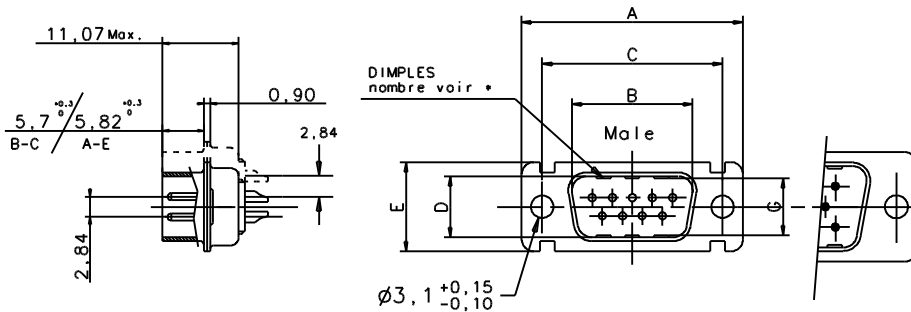

| Taille boîtier | A | B' | B | C | D' | D | E | F ±0,05 | Pas | G | * |
|----------------|-------|------|------|-------|-----|-----|-------|---------|------|------|------|
| E | 11,07 | 6,05 | 5,82 | 11,15 | 3,1 | 3,1 | 12,93 | 10,98 | 2,74 | 7,62 | 2x3 |
| A | 11,07 | 6,05 | 5,82 | 11,15 | 3,1 | 3,1 | 12,93 | 19,20 | 2,74 | 7,62 | 2x5 |
| B | 11,07 | 6,05 | 5,82 | 11,15 | 3,1 | 3,1 | 12,93 | 33,12 | 2,76 | 7,62 | 2x8 |
| C | 11,07 | 6,05 | 5,82 | 11,15 | 3,1 | 3,1 | 12,93 | 49,68 | 2,76 | 7,62 | 2x12 |
| D | 11,07 | 6,05 | 5,82 | 11,15 | 3,1 | 3,1 | 12,93 | 44,20 | 2,76 | 10,5 | 2x12 |

TECHNICAL DATA

'' D '' SUBMINIATURE CONNECTORS

SHELL : Material : Steel
Plating : 100µ" Tin over 78µ" Nickel

BODY : Glass filled thermoplastic
Flame retardant to UL 94 V-0
Colour : black

CONTACTS Material for sockets : Brass
Material for pins : Brass
Plating of mating area : 8µ" minimum Gold over 78µ" Nickel

ELECTRICAL Voltage rating 300 V Rms to 50Hz
Nominal current 7.5 A (size20)
Voltage proof >1000 V Rms to 50 Hz
Contact resistance <8.5m Ohms
Insulator resistance >5000 M Ohms

CLIMATIC Temperature range -55°C +85°C
Damp heart 21 days (40°C - 95 % RH)

MECHANICAL Insertion force per contact 1,2N < F <2,5 N
Extraction force per contact 0,4 N mini
Mating and unmating force size E 30N maxi 3.5N mini
A 50N maxi 4.5N mini
B 83N maxi 8.0N mini
C 123N maxi 11N mini
D 166N maxi 14.5N mini

(With or without dimples)

MARKING Amphenol - ... (serie number)
Commercial reference
Manufacturing date

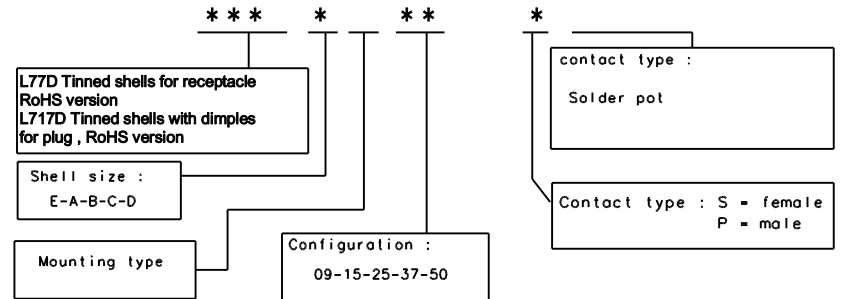

Amphenol Socapex
Usine de Dole

ECHELLE: 1:5

Creation plan 14/01 98
IND. MODIFICATION DATE Execu/Approv

PLAN NOTICE

DOSSIER:

N SERIE

DESIGNATION

a souder / solder pot

17D++++

017F

COMMUNICATION ET UTILISATION INTERDITES SAUF AUTORISATION