

# EV32C6A5A1-24.576M

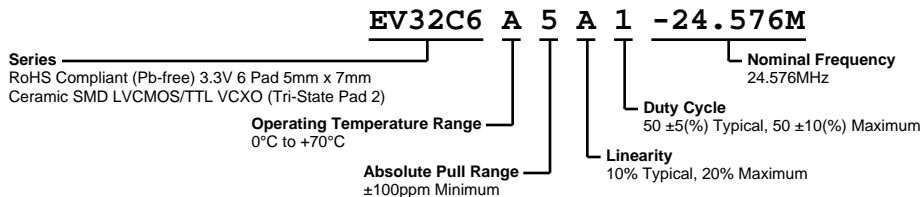

**ECLIPTEK**  
CORPORATION



## ELECTRICAL SPECIFICATIONS

<b>Nominal Frequency</b>	24.576MHz
<b>Frequency Tolerance/Stability</b>	±50ppm Maximum (Inclusive of all conditions: Calibration Tolerance at 25°C, Frequency Stability over the Operating Temperature Range, Supply Voltage Change, Output Load Change, Shock, and Vibration.)
<b>Aging at 25°C</b>	±2ppm/first year Typical, ±10ppm/10 years Maximum
<b>Operating Temperature Range</b>	0°C to +70°C
<b>Supply Voltage</b>	3.3Vdc ±10%
<b>Input Current</b>	15mA Maximum
<b>Output Voltage Logic High (Voh)</b>	90% of Vdd Minimum (IOH = -4mA)
<b>Output Voltage Logic Low (Vol)</b>	10% of Vdd Minimum (IOL = +4mA)
<b>Rise/Fall Time</b>	5nSec Maximum (Measured at 20% to 80% of Waveform)
<b>Duty Cycle</b>	50 ±5(%) Typical, 50 ±10(%) Maximum (Measured at 50% of Waveform)
<b>Load Drive Capability</b>	15pF LVCMOS Load Maximum
<b>Output Logic Type</b>	CMOS
<b>Absolute Pull Range</b>	±100ppm Minimum (Inclusive of all conditions: Calibration Tolerance at 25°C, Frequency Stability over the Operating Temperature Range, Supply Voltage Change, Output Load Change, Shock, Vibration, and Aging over the Control Voltage (Vc).)
<b>Control Voltage</b>	0.3Vdc to 3.0Vdc (Test Condition for Absolute Pull Range)
<b>Control Voltage Range</b>	0.0Vdc to Vdd
<b>Linearity</b>	10% Typical, 20% Maximum
<b>Transfer Function</b>	Positive Transfer Characteristic
<b>Modulation Bandwidth</b>	10kHz Minimum (Measured at -3dB, Vc = 1.65Vdc)
<b>Input Impedance</b>	50kOhms Minimum
<b>Input Leakage Current</b>	10µA Maximum
<b>Phase Noise</b>	-70dBc/Hz at offset of 10Hz, -100dBc/Hz at offset of 100Hz, -130dBc/Hz at offset of 1kHz, -147dBc/Hz at offset of 10kHz, -152dBc/Hz at offset of 100kHz, and -155dBc/Hz at offset of 1MHz (Typical values at Fo = 27MHz)
<b>Tri-State Input Voltage (Vih and Vil)</b>	+0.9Vdd Minimum to Enable Output; +0.1Vdd Maximum to Disable Output (High Impedance); No Connect to Enable Output.
<b>RMS Phase Jitter</b>	1pSec Maximum (Fj = 12kHz to 20MHz)
<b>Start Up Time</b>	10mSec Maximum
<b>Storage Temperature Range</b>	-55°C to +125°C

## ENVIRONMENTAL & MECHANICAL SPECIFICATIONS

<b>ESD Susceptibility</b>	MIL-STD-883, Method 3015, Class 1, HBM: 1500V
<b>Fine Leak Test</b>	MIL-STD-883, Method 1014, Condition A
<b>Flammability</b>	UL94-V0
<b>Gross Leak Test</b>	MIL-STD-883, Method 1014, Condition C
<b>Mechanical Shock</b>	MIL-STD-883, Method 2002, Condition B
<b>Moisture Resistance</b>	MIL-STD-883, Method 1004
<b>Moisture Sensitivity</b>	J-STD-020, MSL 1
<b>Resistance to Soldering Heat</b>	MIL-STD-202, Method 210, Condition K
<b>Resistance to Solvents</b>	MIL-STD-202, Method 215
<b>Solderability</b>	MIL-STD-883, Method 2003
<b>Temperature Cycling</b>	MIL-STD-883, Method 1010, Condition B

# EV32C6A5A1-24.576M

## ENVIRONMENTAL & MECHANICAL SPECIFICATIONS

Vibration MIL-STD-883, Method 2007, Condition A

### MECHANICAL DIMENSIONS (all dimensions in millimeters)

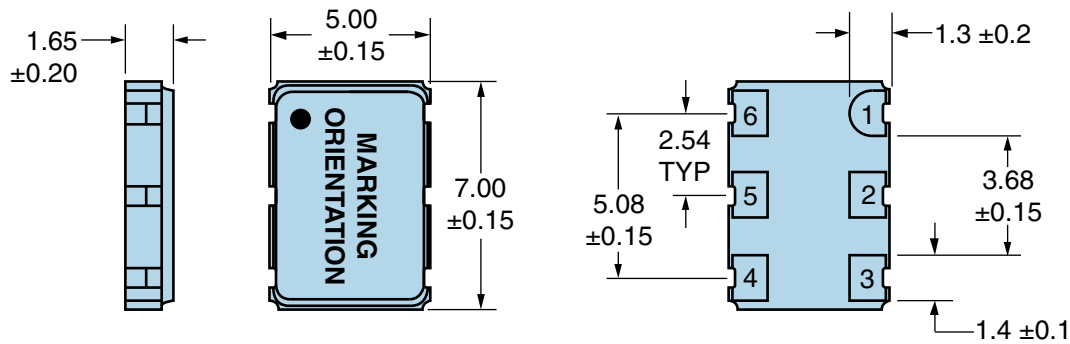

PIN	CONNECTION
1	Control Voltage
2	Tri-State
3	Case Ground
4	Output
5	No Connect
6	Supply Voltage

LINE	MARKING
1	<b>ECLIPTEK</b>
2	<b>24.576M</b>
3	<b>XXYYZ</b> XX=Ecliptek Manufacturing Code Y=Last Digit of Year ZZ=Week of Year

### Suggested Solder Pad Layout

All Dimensions in Millimeters

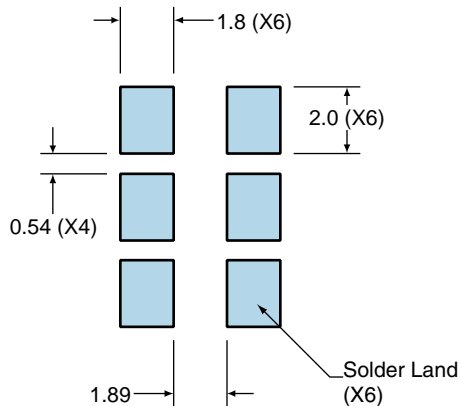

All Tolerances are ±0.1

# EV32C6A5A1-24.576M

## OUTPUT WAVEFORM

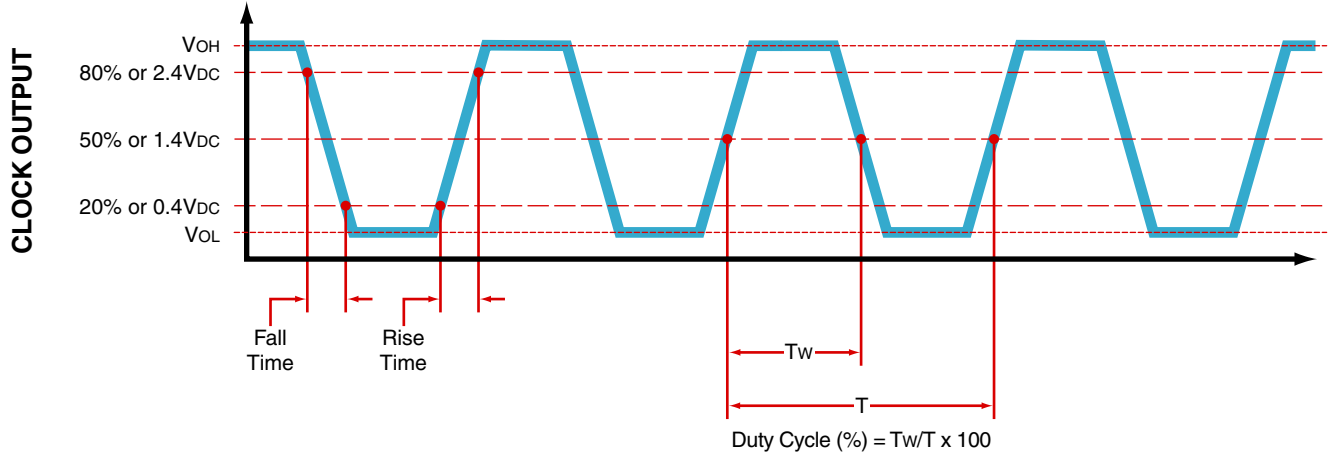

## Test Circuit for CMOS Output

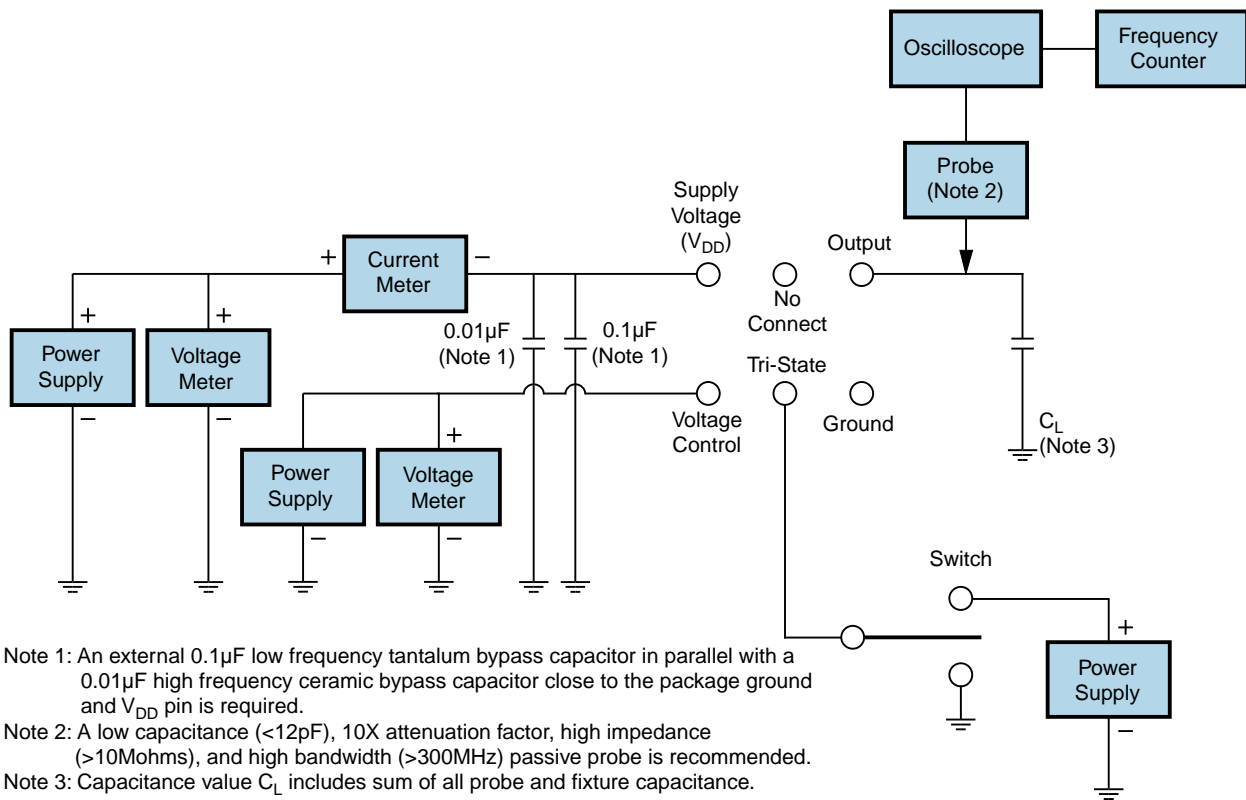

Note 1: An external 0.1  $\mu F$  low frequency tantalum bypass capacitor in parallel with a 0.01  $\mu F$  high frequency ceramic bypass capacitor close to the package ground and  $V_{DD}$  pin is required.

Note 2: A low capacitance (<12pF), 10X attenuation factor, high impedance (>10Mohms), and high bandwidth (>300MHz) passive probe is recommended.

Note 3: Capacitance value  $C_L$  includes sum of all probe and fixture capacitance.

# EV32C6A5A1-24.576M

## Test Circuit for TTL Output

Output Load Drive Capability	R <sub>L</sub> Value (Ohms)	C <sub>L</sub> Value (pF)
10TTL	390	15
5TTL	780	15
2TTL	1100	6
10LSTTL	2000	15
1TTL	2200	3

Table 1: R<sub>L</sub> Resistance Value and C<sub>L</sub> Capacitance Value Vs. Output Load Drive Capability

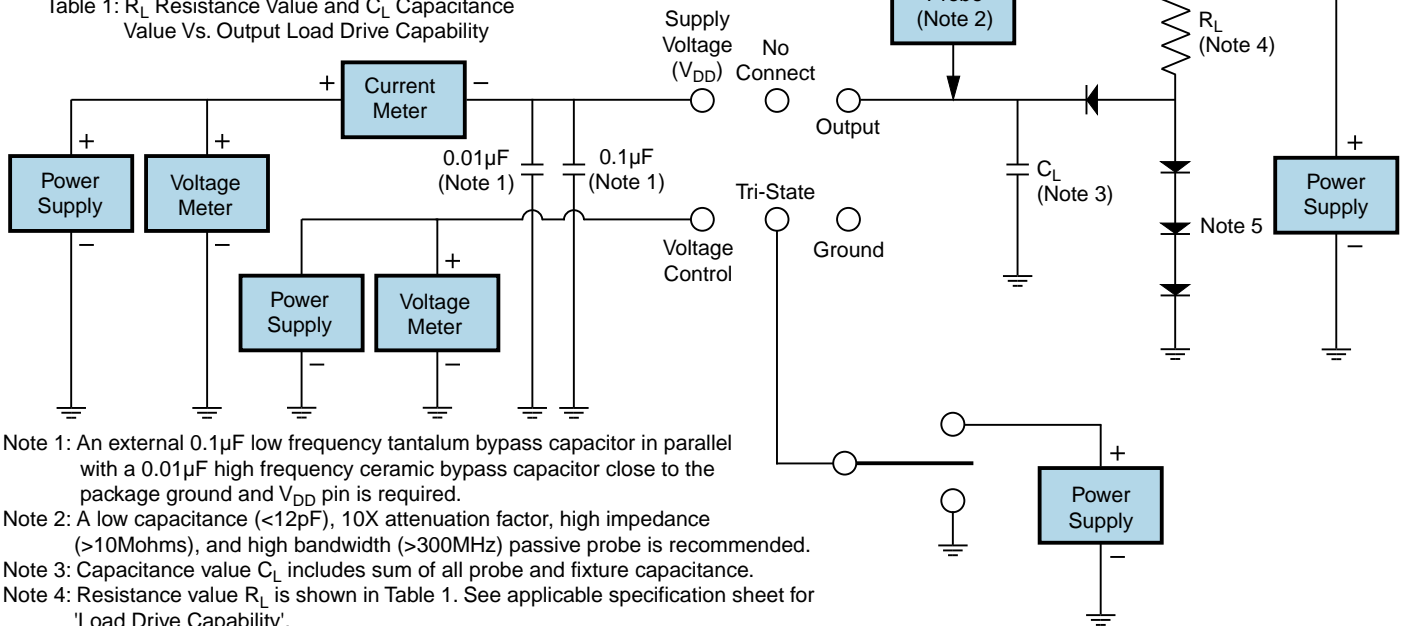

Note 1: An external 0.1µF low frequency tantalum bypass capacitor in parallel with a 0.01µF high frequency ceramic bypass capacitor close to the package ground and V<sub>DD</sub> pin is required.

Note 2: A low capacitance (<12pF), 10X attenuation factor, high impedance (>10Mohms), and high bandwidth (>300MHz) passive probe is recommended.

Note 3: Capacitance value C<sub>L</sub> includes sum of all probe and fixture capacitance.

Note 4: Resistance value R<sub>L</sub> is shown in Table 1. See applicable specification sheet for 'Load Drive Capability'.

Note 5: All diodes are MMBD7000, MMBD914, or equivalent.

## Recommended Solder Reflow Methods



### High Temperature Infrared/Convection

<b><math>T_S</math> MAX to <math>T_L</math> (Ramp-up Rate)</b>	3°C/second Maximum
<b>Preheat</b>	
- Temperature Minimum ( $T_S$ MIN)	150°C
- Temperature Typical ( $T_S$ TYP)	175°C
- Temperature Maximum ( $T_S$ MAX)	200°C
- Time ( $t_s$ MIN)	60 - 180 Seconds
<b>Ramp-up Rate (<math>T_L</math> to <math>T_P</math>)</b>	3°C/second Maximum
<b>Time Maintained Above:</b>	
- Temperature ( $T_L$ )	217°C
- Time ( $t_L$ )	60 - 150 Seconds
<b>Peak Temperature (<math>T_P</math>)</b>	260°C Maximum for 10 Seconds Maximum
<b>Target Peak Temperature (<math>T_P</math> Target)</b>	250°C +0/-5°C
<b>Time within 5°C of actual peak (<math>t_p</math>)</b>	20 - 40 seconds
<b>Ramp-down Rate</b>	6°C/second Maximum
<b>Time 25°C to Peak Temperature (t)</b>	8 minutes Maximum
<b>Moisture Sensitivity Level</b>	Level 1

## Recommended Solder Reflow Methods



### Low Temperature Infrared/Convection 240°C

<b>T<sub>s</sub> MAX to T<sub>L</sub> (Ramp-up Rate)</b>	5°C/second Maximum
<b>Preheat</b>	
- Temperature Minimum (T <sub>s</sub> MIN)	N/A
- Temperature Typical (T <sub>s</sub> TYP)	150°C
- Temperature Maximum (T <sub>s</sub> MAX)	N/A
- Time (t <sub>s</sub> MIN)	60 - 120 Seconds
<b>Ramp-up Rate (T<sub>L</sub> to T<sub>P</sub>)</b>	5°C/second Maximum
<b>Time Maintained Above:</b>	
- Temperature (T <sub>L</sub> )	150°C
- Time (t <sub>L</sub> )	200 Seconds Maximum
<b>Peak Temperature (T<sub>P</sub>)</b>	240°C Maximum
<b>Target Peak Temperature (T<sub>P</sub> Target)</b>	240°C Maximum 1 Time / 230°C Maximum 2 Times
<b>Time within 5°C of actual peak (t<sub>p</sub>)</b>	10 seconds Maximum 2 Times / 80 seconds Maximum 1 Time
<b>Ramp-down Rate</b>	5°C/second Maximum
<b>Time 25°C to Peak Temperature (t)</b>	N/A
<b>Moisture Sensitivity Level</b>	Level 1

### Low Temperature Manual Soldering

185°C Maximum for 10 seconds Maximum, 2 times Maximum.

### High Temperature Manual Soldering

260°C Maximum for 5 seconds Maximum, 2 times Maximum.