

# E13C7D2F-150.000M TR

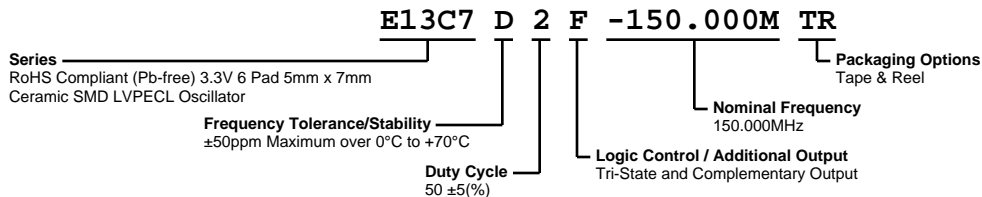

**ECLIPTEK**  
CORPORATION



## ELECTRICAL SPECIFICATIONS

<b>Nominal Frequency</b>	150.000MHz
<b>Frequency Tolerance/Stability</b>	$\pm 50$ ppm Maximum over 0°C to +70°C (Inclusive of all conditions: Calibration Tolerance (at 25°C), Frequency Stability over the Operating Temperature Range, Supply Voltage Change, Output Load Change, First Year Aging at 25°C, Shock, and Vibration)
<b>Supply Voltage</b>	+3.3Vdc $\pm 5$ %
<b>Input Current</b>	75mA Maximum
<b>Output Voltage Logic High (Voh)</b>	Vcc-1.025Vdc Minimum from 0°C to +85°C, Vcc-1.085Vdc Minimum from -40°C to +0°C
<b>Output Voltage Logic Low (Vol)</b>	Vcc-1.620Vdc Maximum from 0°C to +85°C, Vcc-1.555Vdc Maximum from -40°C to +0°C
<b>Rise/Fall Time</b>	300pSec Typical, 700pSec Maximum (Measured at 20% to 80% of Waveform)
<b>Duty Cycle</b>	50 $\pm 5$ (%) (Measured at 50% of Waveform)
<b>Load Drive Capability</b>	50 Ohms into Vcc-2.0Vdc
<b>Output Logic Type</b>	LVPECL
<b>Phase Noise</b>	-60dBc/Hz at 10Hz Offset, -95dBc/Hz at 100Hz Offset, -125dBc/Hz at 1kHz Offset, -143dBc/Hz at 10kHz Offset, -145dBc/Hz at 100kHz Offset, -145dBc/Hz at 1MHz Offset, -146dBc/Hz at 10MHz Offset (All Values are Typical, Fo=156.250MHz)
<b>Logic Control / Additional Output</b>	Tri-State and Complementary Output
<b>Tri-State Input Voltage (Vih and Vil)</b>	Vih of 70% of Vcc Minimum or No Connect to Enable Output and Complementary Output, Vil of 30% of Vcc Maximum to Disable High Impedance Output and Complementary Output
<b>Standby Current</b>	30 $\mu$ A Maximum (Without Load)
<b>RMS Phase Jitter</b>	0.4pSec Typical, 1pSec Maximum (Fj=12kHz to 20MHz)
<b>Start Up Time</b>	10mSec Maximum
<b>Storage Temperature Range</b>	-55°C to +125°C

## ENVIRONMENTAL & MECHANICAL SPECIFICATIONS

<b>ESD Susceptibility</b>	MIL-STD-883, Method 3015, Class 1, HBM: 1500V
<b>Fine Leak Test</b>	MIL-STD-883, Method 1014, Condition A
<b>Flammability</b>	UL94-V0
<b>Gross Leak Test</b>	MIL-STD-883, Method 1014, Condition C
<b>Mechanical Shock</b>	MIL-STD-883, Method 2002, Condition B
<b>Moisture Resistance</b>	MIL-STD-883, Method 1004
<b>Moisture Sensitivity</b>	J-STD-020, MSL 1
<b>Resistance to Soldering Heat</b>	MIL-STD-202, Method 210, Condition K
<b>Resistance to Solvents</b>	MIL-STD-202, Method 215
<b>Solderability</b>	MIL-STD-883, Method 2003
<b>Temperature Cycling</b>	MIL-STD-883, Method 1010, Condition B
<b>Vibration</b>	MIL-STD-883, Method 2007, Condition A

# E13C7D2F-150.000M TR

## MECHANICAL DIMENSIONS (all dimensions in millimeters)

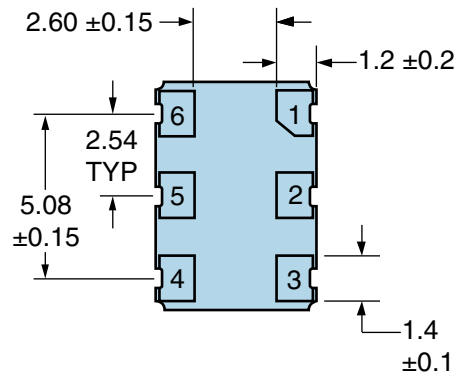
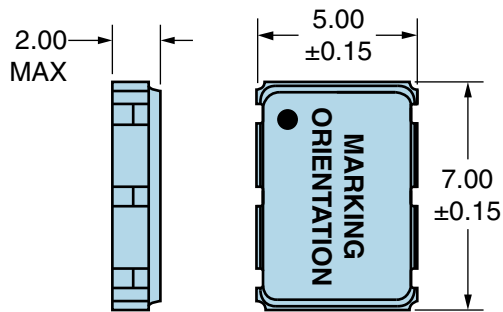

PIN	CONNECTION
1	Tri-State
2	No Connect
3	Case/Ground
4	Output
5	Complementary Output
6	Supply Voltage

LINE	MARKING
1	<b>ECLIPTEK</b>
2	<b>150.00M</b>
3	<b>XXYZZ</b> XX=Ecliptek Manufacturing Code Y=Last Digit of the Year ZZ=Week of the Year

## Suggested Solder Pad Layout

All Dimensions in Millimeters

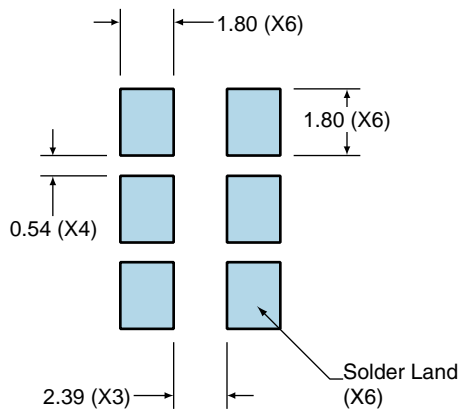

All Tolerances are ±0.1

# E13C7D2F-150.000M TR

## Test Circuit for Tri-State and Complementary Output

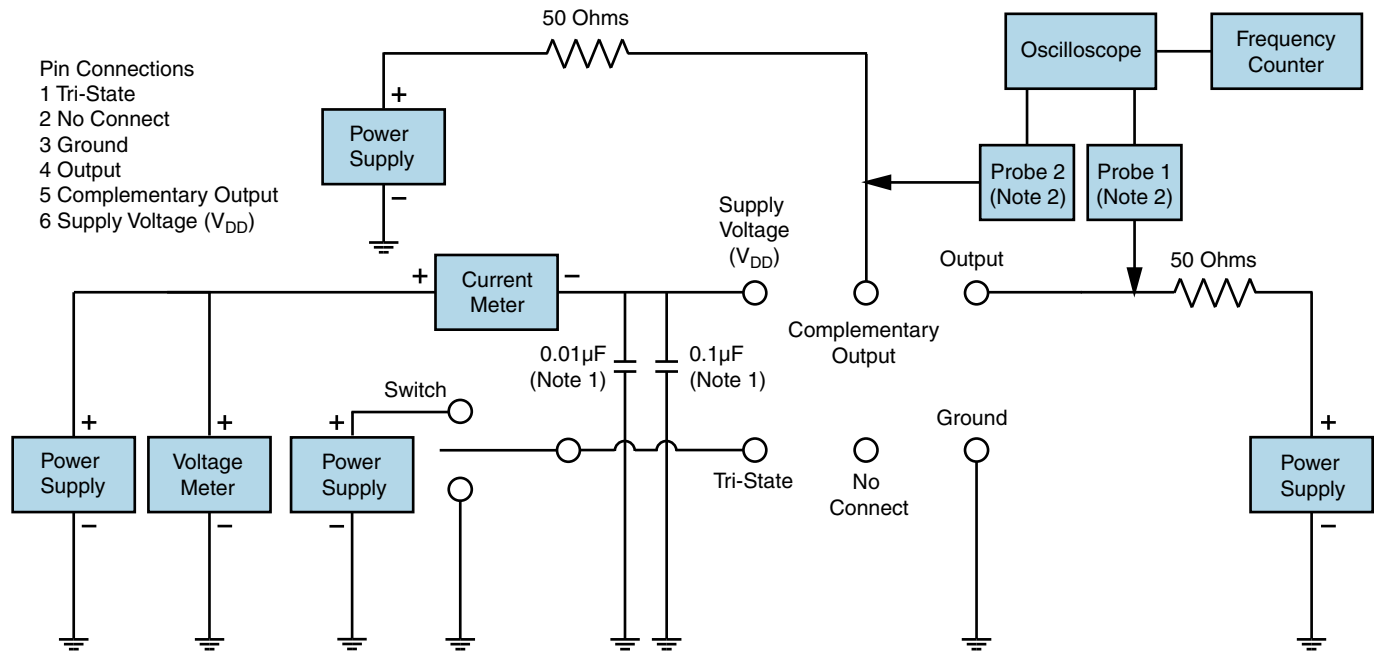

Note 1: An external 0.01  $\mu\text{F}$  ceramic bypass capacitor in parallel with a 0.1  $\mu\text{F}$  high frequency ceramic bypass capacitor close (less than 2mm) to the package ground and supply voltage pin is required.

Note 2: A low capacitance (<12pF), 10X attenuation factor, high impedance (>10Mohms), and high bandwidth (>500MHz) passive probe is recommended.

Note 3: Test circuit PCB traces need to be designed for a characteristic line impedance of 50 ohms.

# E13C7D2F-150.000M TR

## Tape & Reel Dimensions

Quantity Per Reel: 1,000 units

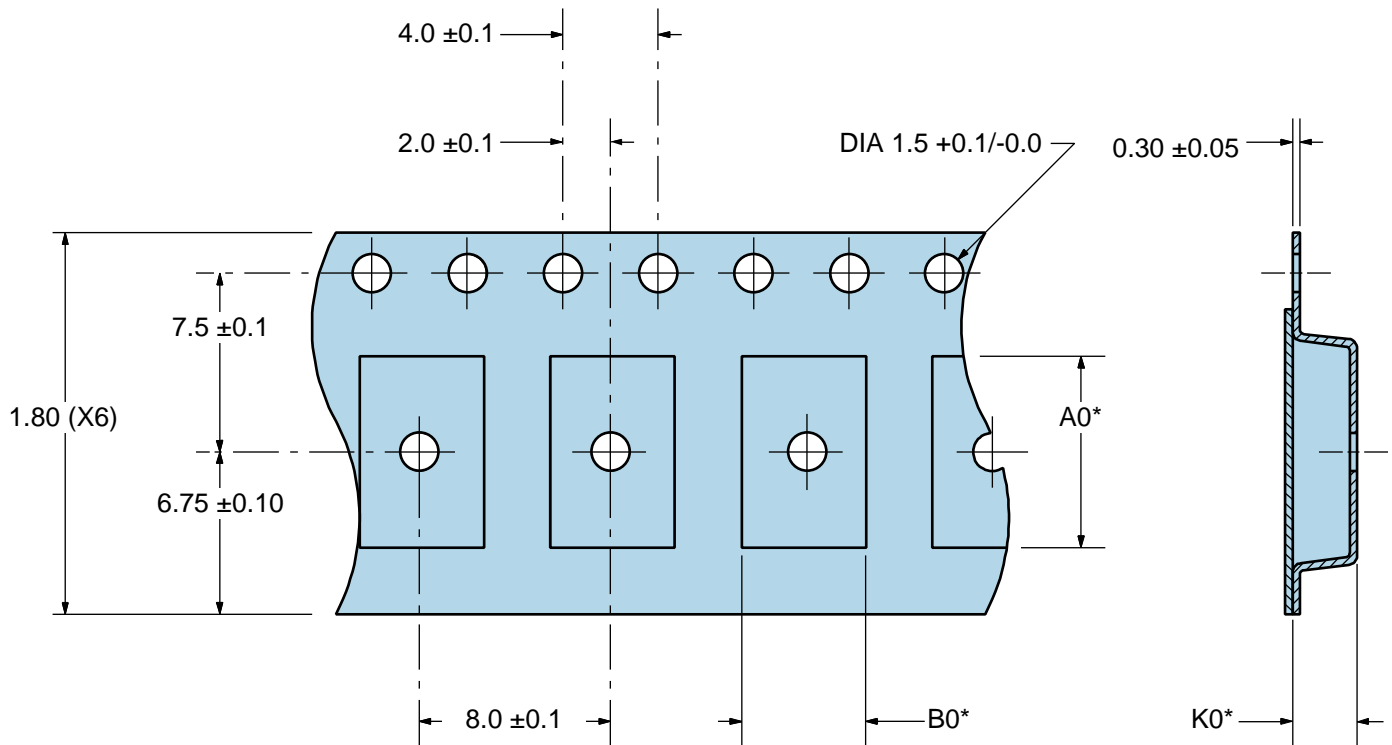

\*Compliant to EIA 481A



## Recommended Solder Reflow Methods



### High Temperature Infrared/Convection

<b><math>T_S\ MAX</math> to <math>T_L</math> (Ramp-up Rate)</b>	3°C/second Maximum
<b>Preheat</b>	
- Temperature Minimum ( $T_S\ MIN$ )	150°C
- Temperature Typical ( $T_S\ TYP$ )	175°C
- Temperature Maximum ( $T_S\ MAX$ )	200°C
- Time ( $t_s\ MIN$ )	60 - 180 Seconds
<b>Ramp-up Rate (<math>T_L</math> to <math>T_P</math>)</b>	3°C/second Maximum
<b>Time Maintained Above:</b>	
- Temperature ( $T_L$ )	217°C
- Time ( $t_L$ )	60 - 150 Seconds
<b>Peak Temperature (<math>T_P</math>)</b>	260°C Maximum for 10 Seconds Maximum
<b>Target Peak Temperature (<math>T_P\ Target</math>)</b>	250°C +0/-5°C
<b>Time within 5°C of actual peak (<math>t_p</math>)</b>	20 - 40 seconds
<b>Ramp-down Rate</b>	6°C/second Maximum
<b>Time 25°C to Peak Temperature (t)</b>	8 minutes Maximum
<b>Moisture Sensitivity Level</b>	Level 1

# E13C7D2F-150.000M TR

## Recommended Solder Reflow Methods



### Low Temperature Infrared/Convection 240°C

<b><math>T_s</math> MAX to <math>T_L</math> (Ramp-up Rate)</b>	5°C/second Maximum
<b>Preheat</b>	
- Temperature Minimum ( $T_s$ MIN)	N/A
- Temperature Typical ( $T_s$ TYP)	150°C
- Temperature Maximum ( $T_s$ MAX)	N/A
- Time ( $t_s$ MIN)	60 - 120 Seconds
<b>Ramp-up Rate (<math>T_L</math> to <math>T_p</math>)</b>	5°C/second Maximum
<b>Time Maintained Above:</b>	
- Temperature ( $T_L$ )	150°C
- Time ( $t_L$ )	200 Seconds Maximum
<b>Peak Temperature (<math>T_p</math>)</b>	240°C Maximum
<b>Target Peak Temperature (<math>T_p</math> Target)</b>	240°C Maximum 1 Time / 230°C Maximum 2 Times
<b>Time within 5°C of actual peak (<math>t_p</math>)</b>	10 seconds Maximum 2 Times / 80 seconds Maximum 1 Time
<b>Ramp-down Rate</b>	5°C/second Maximum
<b>Time 25°C to Peak Temperature (t)</b>	N/A
<b>Moisture Sensitivity Level</b>	Level 1

### Low Temperature Manual Soldering

185°C Maximum for 10 seconds Maximum, 2 times Maximum.

### High Temperature Manual Soldering

260°C Maximum for 5 seconds Maximum, 2 times Maximum.