

E32D1HEA2K-155.520M

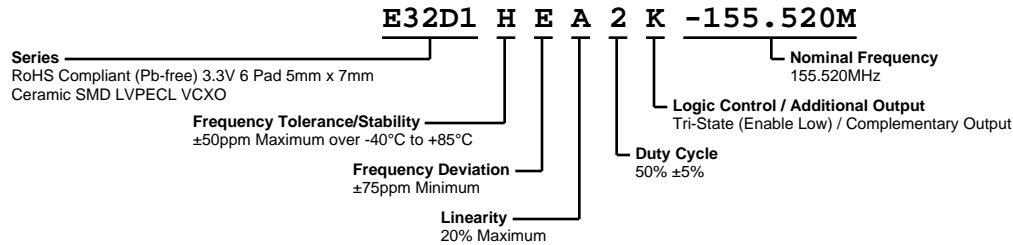

ELECTRICAL SPECIFICATIONS

Nominal Frequency	155.520MHz
Frequency Tolerance/Stability	± 50 ppm Maximum over -40°C to $+85^{\circ}\text{C}$ (Inclusive of all conditions: Calibration Tolerance at 25°C , Frequency Stability over the Operating Temperature Range, Supply Voltage Change, Output Load Change, 1st Year Aging at 25°C , Shock, and Vibration.)
Supply Voltage	3.3Vdc $\pm 5\%$
Input Current	100mA Maximum (with Load)
Output Voltage Logic High (Voh)	Vcc-1.025Vdc Minimum
Output Voltage Logic Low (Vol)	Vcc-1.620Vdc Maximum
Rise/Fall Time	1.5nSec Maximum (Measured over 20% to 80% of waveform)
Duty Cycle	50% $\pm 5\%$ (Measured at 50% of waveform)
Load Drive Capability	50 Ohms into Vcc-2.0Vdc
Output Logic Type	LVPECL
Control Voltage	1.65Vdc ± 1.65 Vdc (Test Conditions for Frequency Deviation)
Control Voltage Range	0.0Vdc to Vcc +0.5Vdc
Frequency Deviation	± 75 ppm Minimum (Inclusive of Operating Temperature Range, Supply Voltage, and Load)
Linearity	20% Maximum
Transfer Function	Positive Transfer Characteristic
Modulation Bandwidth	10kHz Minimum (Measured at -3dB with a control voltage of +1.65Vdc)
Input Impedance	50kOhms Typical
Phase Noise	-55dBc/Hz at 10Hz offset, -90dBc/Hz at 100Hz offset, -120dBc/Hz at 1kHz offset, -140dBc/Hz at 10kHz offset, -145dBc/Hz at 100kHz offset, -148dBc/Hz at 1MHz (Typical Values, Fo=155.520MHz)
Logic Control / Additional Output	Tri-State (Enable Low) / Complementary Output
Tri-State Input Voltage (Vih and Vil)	Vih of 70% of Vcc Minimum to Disable Outputs (High Impedance), Vil of 30% of Vcc Maximum or No Connect to Enable Outputs
RMS Phase Jitter	0.4pSec Typical, 1pSec Maximum (Fj=12kHz to 20MHz)
Accumulated Period Jitter (tacc)	4pSec Typical, 5pSec Maximum Sigma of Total Jitter Distribution
Period Jitter (trj)	3pSec Typical, 5pSec Maximum Sigma of Random Jitter
Period Jitter (trms)	3pSec Typical, 5pSec Maximum Sigma of Total Jitter Distribution
Period Jitter (tdj)	4pSec Typical, 10pSec Maximum Deterministic Jitter
Period Jitter (tp-p)	27pSec Typical, 40pSec Maximum Peak to Peak of Jitter Distribution
Start Up Time	10mSec Maximum
Storage Temperature Range	-55°C to $+125^{\circ}\text{C}$

ENVIRONMENTAL & MECHANICAL SPECIFICATIONS

Fine Leak Test	MIL-STD-883, Method 1014 Condition A
Gross Leak Test	MIL-STD-883, Method 1014 Condition C
Mechanical Shock	MIL-STD-202, Method 213 Condition C
Resistance to Soldering Heat	MIL-STD-202, Method 210
Resistance to Solvents	MIL-STD-202, Method 215
Solderability	MIL-STD-883, Method 2003
Temperature Cycling	MIL-STD-883, Method 1010
Vibration	MIL-STD-883, Method 2007 Condition A

E32D1HEA2K-155.520M

MECHANICAL DIMENSIONS (all dimensions in millimeters)

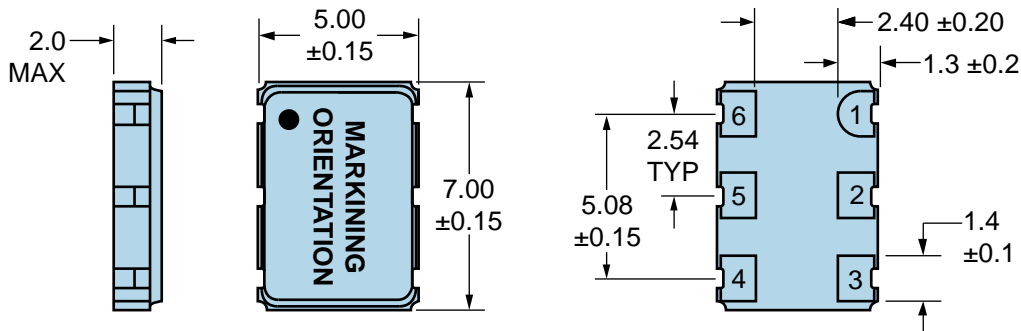

PIN	CONNECTION
1	Voltage Control
2	Tri-State
3	Case/Ground
4	Output
5	Complementary Output
6	Supply Voltage

LINE	MARKING
1	ECLIPTEK
2	155.52M
3	XXYZZ <i>XX=Ecliptek Manufacturing Code</i> <i>Y=Last Digit of the Year</i> <i>ZZ=Week of the Year</i>

Suggested Solder Pad Layout

All Dimensions in Millimeters

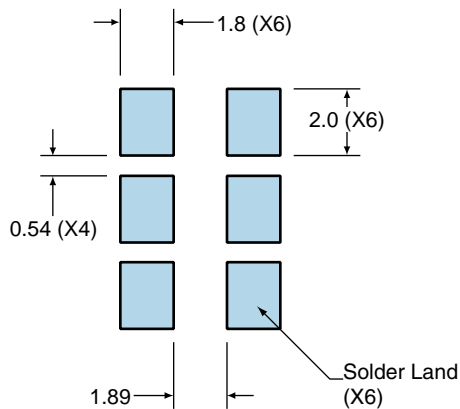

All Tolerances are ±0.1

E32D1HEA2K-155.520M

Test Circuit for Tri-State and Complementary Output

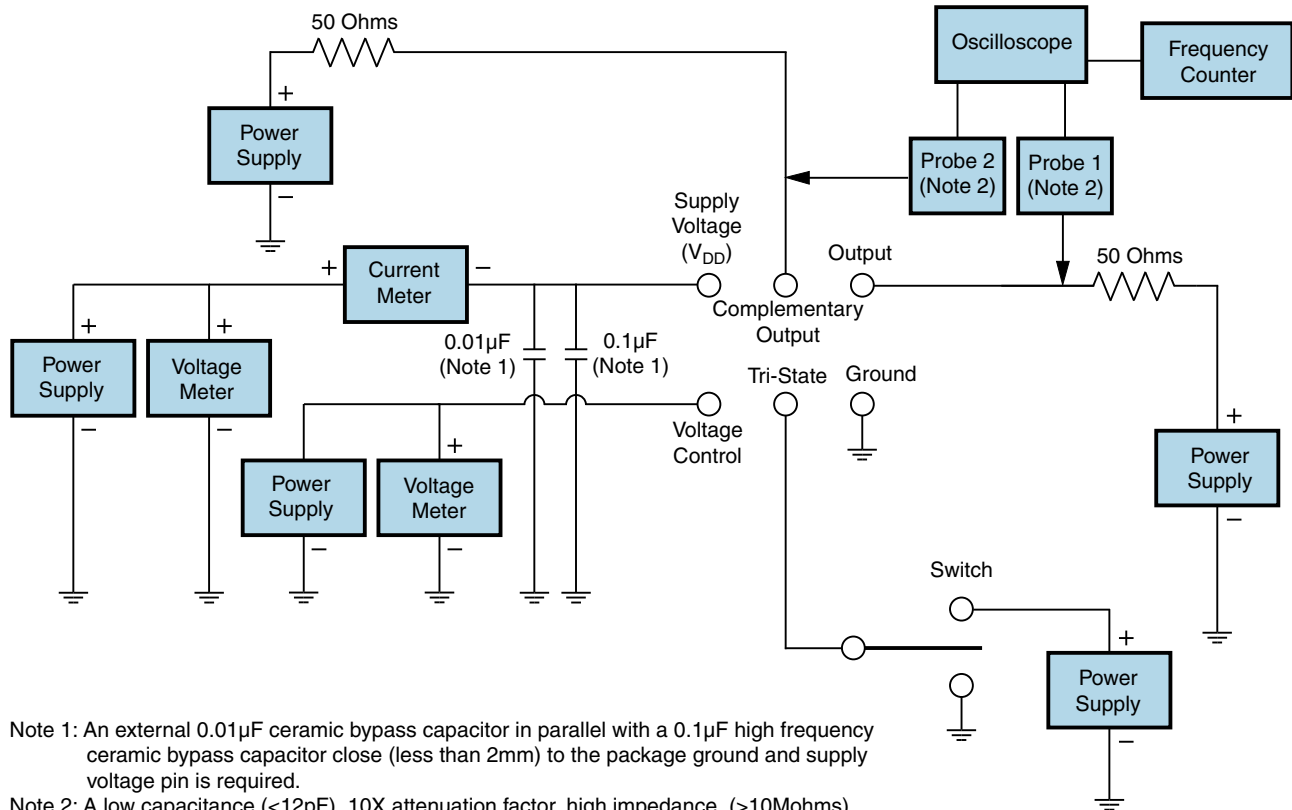

Note 1: An external $0.01\mu\text{F}$ ceramic bypass capacitor in parallel with a $0.1\mu\text{F}$ high frequency ceramic bypass capacitor close (less than 2mm) to the package ground and supply voltage pin is required.

Note 2: A low capacitance ($<12\text{pF}$), 10X attenuation factor, high impedance ($>10\text{Mohms}$), and high bandwidth ($>500\text{MHz}$) passive probe is recommended.

Note 3: Test circuit PCB traces need to be designed for a characteristic line impedance of 50 ohms.

Recommended Solder Reflow Methods



High Temperature Infrared/Convection

T_s MAX to T_L (Ramp-up Rate)	3°C/second Maximum
Preheat	
- Temperature Minimum (T_s MIN)	150°C
- Temperature Typical (T_s TYP)	175°C
- Temperature Maximum (T_s MAX)	200°C
- Time (t_s MIN)	60 - 180 Seconds
Ramp-up Rate (T_L to T_p)	3°C/second Maximum
Time Maintained Above:	
- Temperature (T_L)	217°C
- Time (t_L)	60 - 150 Seconds
Peak Temperature (T_p)	260°C Maximum for 10 Seconds Maximum
Target Peak Temperature (T_p Target)	250°C +0/-5°C
Time within 5°C of actual peak (t_p)	20 - 40 seconds
Ramp-down Rate	6°C/second Maximum
Time 25°C to Peak Temperature (t)	8 minutes Maximum
Moisture Sensitivity Level	Level 1

Recommended Solder Reflow Methods



Low Temperature Infrared/Convection 240°C

T_S MAX to T_L (Ramp-up Rate)	5°C/second Maximum
Preheat	
- Temperature Minimum (T_S MIN)	N/A
- Temperature Typical (T_S TYP)	150°C
- Temperature Maximum (T_S MAX)	N/A
- Time (t_S MIN)	60 - 120 Seconds
Ramp-up Rate (T_L to T_P)	5°C/second Maximum
Time Maintained Above:	
- Temperature (T_L)	150°C
- Time (t_L)	200 Seconds Maximum
Peak Temperature (T_P)	240°C Maximum
Target Peak Temperature (T_P Target)	240°C Maximum 1 Time / 230°C Maximum 2 Times
Time within 5°C of actual peak (t_p)	10 seconds Maximum 2 Times / 80 seconds Maximum 1 Time
Ramp-down Rate	5°C/second Maximum
Time 25°C to Peak Temperature (t)	N/A
Moisture Sensitivity Level	Level 1

Low Temperature Manual Soldering

185°C Maximum for 10 seconds Maximum, 2 times Maximum.

High Temperature Manual Soldering

260°C Maximum for 5 seconds Maximum, 2 times Maximum.