

**0327/0351/0373**

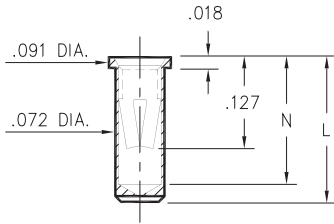

Basic Part Number	Length L	Depth N
0327-0	.206	.180
0351-0	.226	.200
0373-0	.270	.241

**03XX-0-15-XX-34-XX-10-0**

Solder mount in .075 min. mounting hole  
Also available on 12mm wide carrier tape: 1,400 parts per 13" reel.  
Order as: 0327-0-57-XX-34-XX-10-0

**0328**

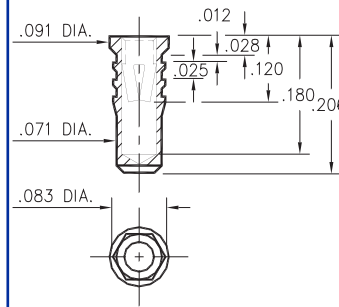

**0328-0-15-XX-34-XX-10-0**

Hex press-fit in .079 plated thru hole

**0334**

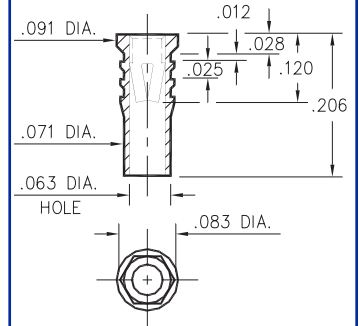

**0334-0-15-XX-34-XX-10-0**

Hex press-fit in .079 plated thru hole

**0312**

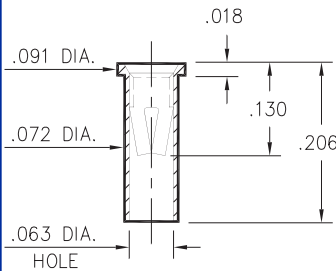

**0312-0-15-XX-34-XX-10-0**

Solder mount in .075 min. mounting hole

**0333**

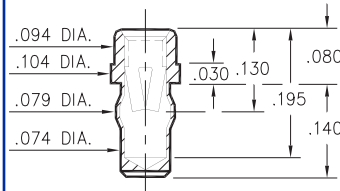

**0333-0-42-XX-34-XX-10-0**

Press-fit in .076 mounting hole

**0357**

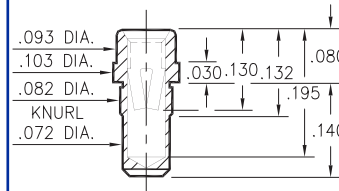

**0357-0-15-XX-34-XX-10-0**

Press-fit in .078 mounting hole

**0317**

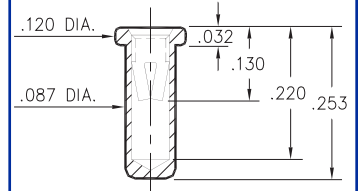

**0317-0-15-XX-34-XX-10-0**

Solder mount in .091 min. mounting hole

**0340**

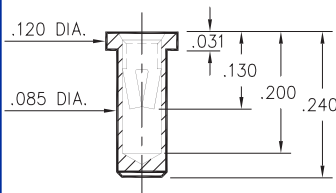

**0340-0-15-XX-34-XX-10-0**

Solder mount in .087 min. mounting hole

**0345**

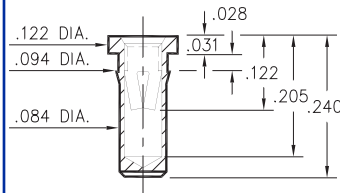

**0345-0-15-XX-34-XX-10-0**

Press-fit in .089 mounting hole

**0316**

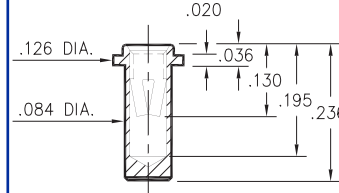

**0316-0-15-XX-34-XX-10-0**

Solder mount in .087 min. mounting hole

**0314**

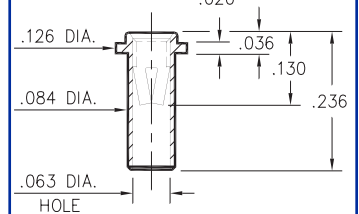

**0314-0-15-XX-34-XX-10-0**

Solder mount in .087 min. mounting hole

**SPECIFICATIONS**

**SHELL MATERIAL:**  
Brass Alloy 360, 1/2 Hard

**CONTACT MATERIAL:**  
Beryllium Copper Alloy 172, HT

**DIMENSION IN INCHES**  
**TOLERANCES ON:**  
LENGTHS: ±.005  
DIAMETERS: ±.002  
ANGLES: ± 2°

**ORDER CODE: XXXX - X - XX - XX - 34 - XX - 10 - 0**

**BASIC PART #**

**SPECIFY SHELL FINISH:**  
01 200µ" TIN/LEAD OVER NICKEL  
80 200µ" TIN OVER NICKEL  
15 10µ" GOLD OVER NICKEL

**SPECIFY CONTACT FINISH:**  
01 200µ" TIN/LEAD OVER NICKEL  
80 200µ" TIN OVER NICKEL  
27 30µ" GOLD OVER NICKEL



**CONTACT**

#34 CONTACT (DATA ON PAGE 222)