**ECONOMATE II Connector Receptacle and Blade Header
Assembly**

1. SCOPE

1.1. Content

This specification covers performance, tests and quality requirements for the Tyco Electronics ECONOMATE II Connector Assembly.

1.2. Qualification

When tests are performed on the subject product line, procedures specified in Figure 1 shall be used. All inspections shall be performed using the applicable inspection plan and product drawing.

2. APPLICABLE DOCUMENTS

The following Government documents form a part of this specification to the extent specified herein. Unless otherwise specified, the latest edition of the document applies. In the event of conflict between the requirements of this specification and the product drawing, the product drawing shall take precedence. In the event of conflict between the requirements of this specification and the referenced documents, this specification shall take precedence.

- ! MIL-C-28754: Connectors, Electrical, Modular, and Component Parts General Specification for
- ! MIL-C-45662: Calibration of Standards
- ! MIL-W-16867: Wire, Electrical, Insulated High Temperature
- ! MIL-STD-105: Sampling Procedures and Tables for Inspection by Attributes
- ! MIL-STD-202: Test Methods for Electronic and Component Parts
- ! MIL-STD-1285: Marking of Electrical and Electronic Parts

3. REQUIREMENTS

3.1. Design and Construction

Product shall be of the design, construction and physical dimensions specified on the applicable product drawing. When required, each connector shall be identified by part number and date coded in accordance with applicable portions of MIL-STD-1285.

3.2. Materials

Materials used in the construction of this product shall be as specified on the applicable product drawing.

3.3. Ratings

- ! Voltage: 800 volts rms
- ! Current: 3 amperes maximum unless otherwise restricted by the PCB or circuit wiring
- ! Temperature: -55 to 105°C

3.4. Performance and Test Description

Product is designed to meet the electrical, mechanical and environmental performance requirements specified in Figure 1. Unless otherwise specified, all tests shall be performed at ambient environmental conditions. Measurements shall be taken using instruments that have been calibrated in accordance with MIL-C-45662.

3.5. Test Requirements and Procedures Summary

Test Description	Requirement	Procedure
Examination of product.	Specimens shall be free of burrs and all contact edges except for the wire-wrap tail shall be free of sharp edges. No evidence of other physical damage or defects that would impair normal function.	Visual inspection.
ELECTRICAL		
Low level contact resistance.	1 ohm maximum.	Subject each pair of mated contacts to 1 milliamperes maximum and 20 millivolts maximum open circuit voltage. See Figure 3.
Contact resistance.	8 milliohms maximum.	MIL-STD-202, Method 307. Measure contact resistance across each pair of mated contacts using a test current of 1 ampere DC. See Figure 3.
Insulation resistance.	25,000 megohms minimum.	MIL-STD-202, Method 302, Test Condition B, 500 volts DC. Test between all contacts and between insulated contacts and conductive mounting plate, if applicable.
Dielectric withstanding voltage.	One minute hold with no breakdown or flashover.	MIL-STD-202, Method 301. 1,000 volts AC at sea level. Test between all contacts and between insulated contacts and conductive mounting plate, if applicable.
Current overload.	See Note.	Subject series wired mated contacts to a DC current overload of 125% of rated current (3.75 amperes) for a period of 2 hours, immediately followed by an increase to 150% of rated current (4.5 amperes) for 5 minutes, then current off.
MECHANICAL		
Vibration.	No discontinuities of 1 microsecond or longer duration. See Note.	MIL-STD-202, Method 204, Test Condition B. Subject specimens to 10 to 2,000 Hz.
Physical shock.	No discontinuities of 1 microsecond or longer duration. See Note.	MIL-STD-202, Method 213, Test Condition B.

Figure 1 (continued)

Test Description	Requirement	Procedure
Durability.	See Note.	Mate and unmate specimens with a corresponding blade header assembly for 100 cycles at a maximum rate of 10 cycles per minute.
Engaging force.	10 ounces maximum average per contact.	Measure force required to mate specimens with a corresponding blade header assembly.
Separating force.	1 ounce minimum average per contact.	Measure force required to withdraw a minimum size gage from each individual contact. See Figure 4.
Contact retention.	Contacts shall not dislodge when a minimum axial force of 15 pounds for soldered contacts and 7 pounds for press-fit contacts is applied in either direction.	Apply specified axial load to contact posts in a direction toward the connector and hold for 5 to 10 seconds.
Torque.	Contacts shall not dislodge when a maximum force of 3 inch-ounces is applied in both directions.	Apply specified force to the base of each contact post in both clockwise and counterclockwise directions and hold for 5 to 15 seconds.
Pin shield retention.	Pin shield shall not separate from the housing nor exhibit damage or defects that would impair normal function when a maximum force of 4 pounds is applied to each end of each pin shield.	MIL-C-28754, paragraph 4.9.6. Apply specified force in a direction normal to a plane passing through the center line of both keying pins midway between the first and second cavities and .062 +.000/-.031 inch from the bottom edge of the shield. See Figure 5.
ENVIRONMENTAL		
Thermal shock.	See Note.	MIL-STD-202, Method 107, Test Condition A. Subject specimens to 5 cycles between -55 and 105°C.
Salt spray.	See Note.	MIL-STD-202, Method 101, Test Condition B. Subject specimens to 5% salt spray solution for 48 hours. After exposure, specimens shall be thoroughly washed using tap water and dried at 100°F for 24 hours before proceeding with additional testing.

Figure 1 (continued)

Test Description	Requirement	Procedure
Humidity.	See Note.	MIL-STD-202, Method 103, Test Condition B. Subject specimens to 90 to 95% RH at 40°C for 96 hours. After exposure, additional measurements shall be taken within 1 to 2 hours after the specimens are removed from the chamber.

NOTE

Shall meet visual requirements, show no physical damage, and meet requirements of additional tests as specified in the Product Qualification and Requalification Test Sequence shown in Figure 2.

Figure 1 (end)

3.6. Product Qualification and Requalification Test Sequence

Test or Examination	Test Group (a)			
	1	2	3	4
	Test Sequence (b)			
Examination of product	1	1	1	1
Low level contact resistance	2	2,10	2	
Contact resistance	3,8	3,7,11	3	
Insulation resistance	10		8	
Dielectric withstanding voltage	9			
Current overload	7			
Vibration	11			
Physical shock			6	
Durability		6		
Engaging and separating force	4	4,8	4	
Contact retention	12	12	9	
Torque	5	5	5	
Pin shield retention				2
Thermal shock	6			
Salt spray		9		
Humidity			7	

NOTE

- (a) See paragraph 4.1.A.
- (b) Numbers indicate sequence in which tests are performed.

Figure 2

4. QUALITY ASSURANCE PROVISIONS

4.1. Qualification Testing

A. Specimen Selection

Specimens shall be prepared in accordance with applicable Instruction Sheets and shall be selected at random from current production. Each test group shall consist of 4 specimens. Four inch lengths of 26 AWG MIL-W-16867 Type E wire shall be terminated to each connector post in such a manner to facilitate the test requirements for each specimen.

B. Test Sequence

Qualification inspection shall be verified by testing specimens as specified in Figure 2.

4.2. Requalification Testing

If changes significantly affecting form, fit or function are made to the product or manufacturing process, product assurance shall coordinate requalification testing, consisting of all or part of the original testing sequence as determined by development/product, quality and reliability engineering.

4.3. Acceptance

Acceptance is based on verification that the product meets the requirements of Figure 1. Failures attributed to equipment, test setup or operator deficiencies shall not disqualify the product. If product failure occurs, corrective action shall be taken and specimens resubmitted for qualification. Testing to confirm corrective action is required before resubmittal.

4.4. Quality Conformance Inspection

MIL-STD-105 shall specify the sampling acceptable quality level to be used. Dimensional and functional requirements shall be in accordance with the applicable product drawing and this specification.

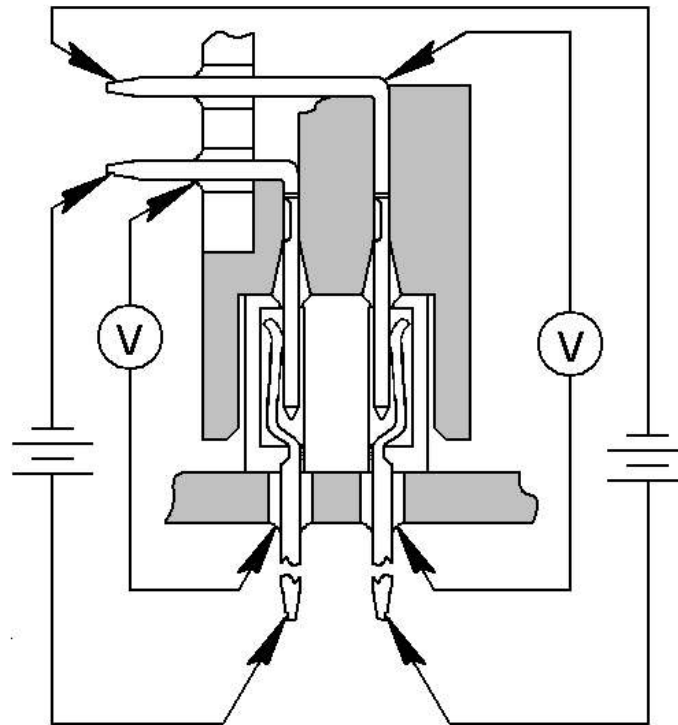

Type Hole	Drill Size (mm)	Drilled Hole Diameter (±.0010)	Plating Thickness		Hole Diameter		Copper Hardness (Knoop)	Minimum Pad Diameter	
			Copper	Tin/Lead	After Plating	After Reflow			
A	1.15	.0453	.001 to .003	.0003 min	.037 to .043	.036 to .043	150 max	.062	
Z	1.15	.0453	Not plated thru						.065

Required Hole Diameter Tolerances For ECONOMATE II .025 inch Square ACTION PIN*

Figure 3
Contact Resistance Measurement Points

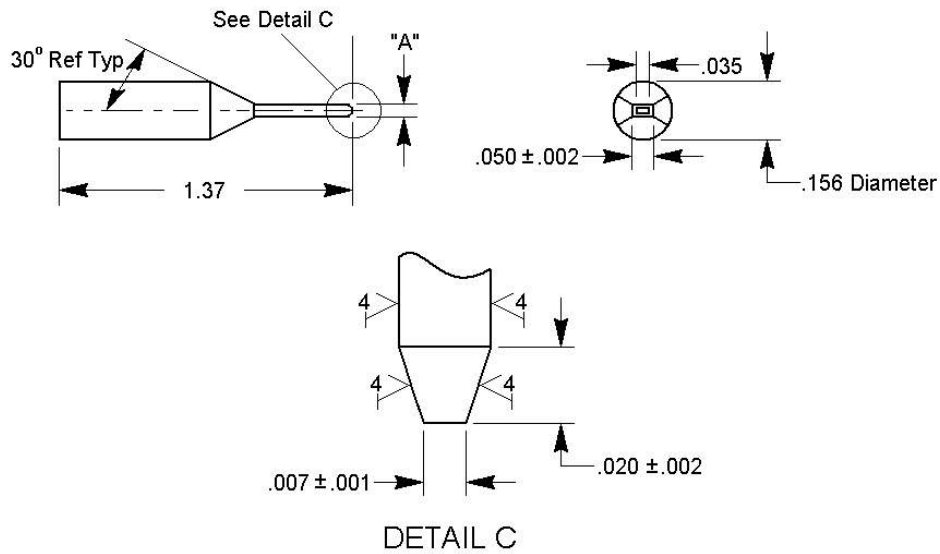

- NOTE**
1. "A" dimension shall be $.0191 \pm .0001$
 2. Only the designated working surfaces shall be finished to 4 microinches to .37 inch from the end.
 3. Unless otherwise specified, tolerances shall be $.00 = \pm .02$; $.000 = \pm .005$. Remove burrs, break sharp edges .015 inch radius maximum.
 4. Material shall be hardened tool steel, Rockwell "C" 63 to 64.

Figure 4
Individual Contact Test Gage

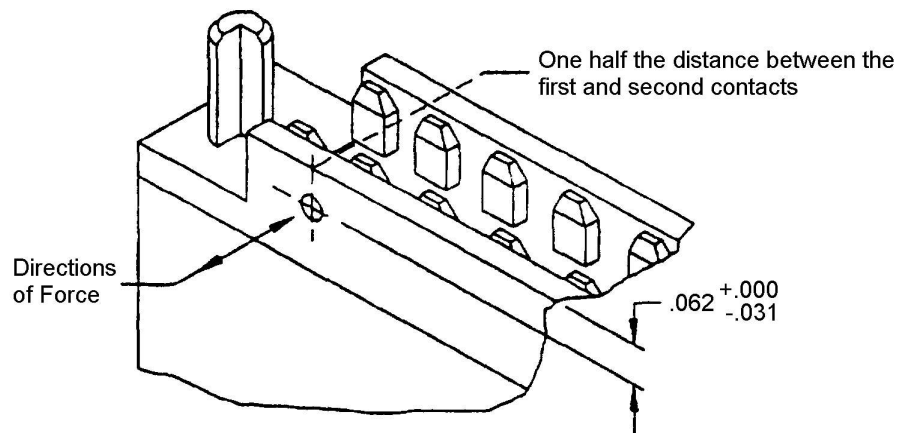

- NOTE** On connectors having rows with 20 contacts, the force is applied at 4 different points for a total of 8 measurements.

Figure 5
Pin Shield Retention