

LOC		DIST		REVISIONS			
DF	ZO	P	LYR	DESCRIPTION	DATE	DMW	APVD
		0	REL PER	0600-2722-94	10-4-94	TA	GG

- △ HOUSING, THERMOSET, COLOR: BLUE
- △ BERYLLIUM COPPER
- △ GOLD FLASH OVER .000050 (0.00127) NICKEL ALL OVER (EXCEPT SHEARED EDGES) .000050 (0.00127) GOLD IN CONTACT AREA, SOLDER TAILS PRE-TINNED WITH 63/37 TIN-LEAD, .020 MAX FROM HOUSING SEATING PLANE.
- △ THESE DIMENSIONS PERTAIN TO CAVITY CENTER LINES—NOT TO CONTACT LOCATIONS.
- △ AMP, DATE CODE, AMP PART NUMBER AND THE WORD 'FRONT'.
- △ SLOT OPTIONAL AT INDICATED AREAS OF HOUSING.

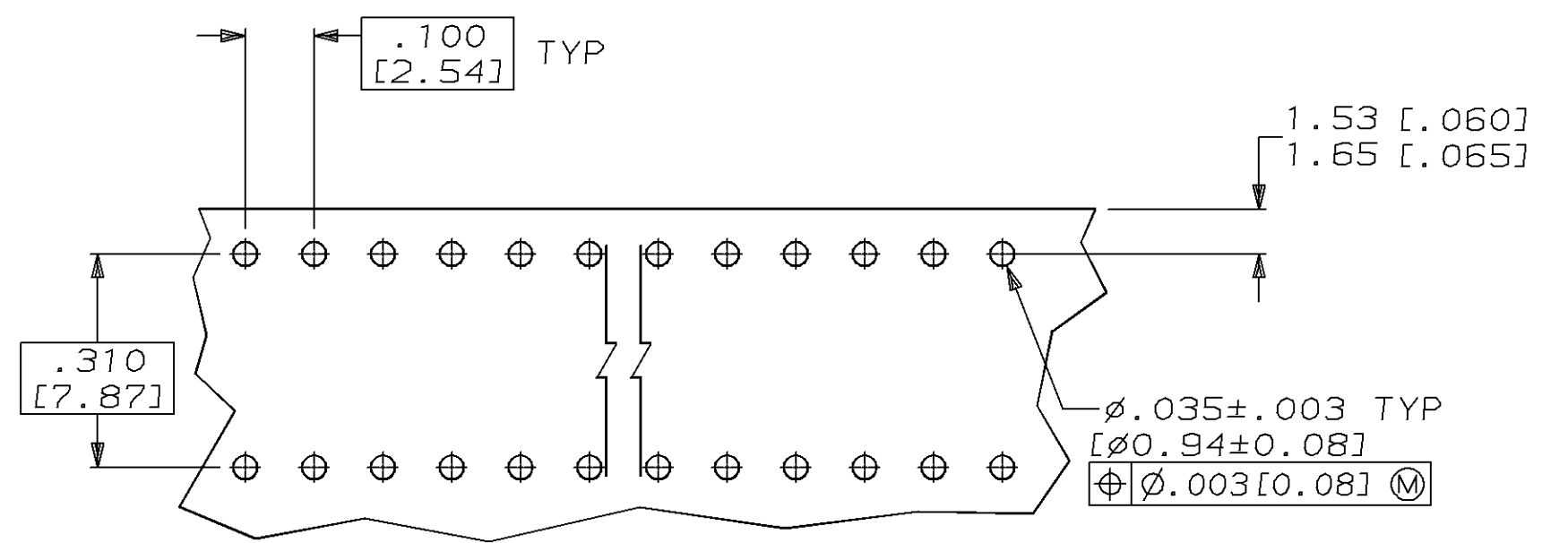
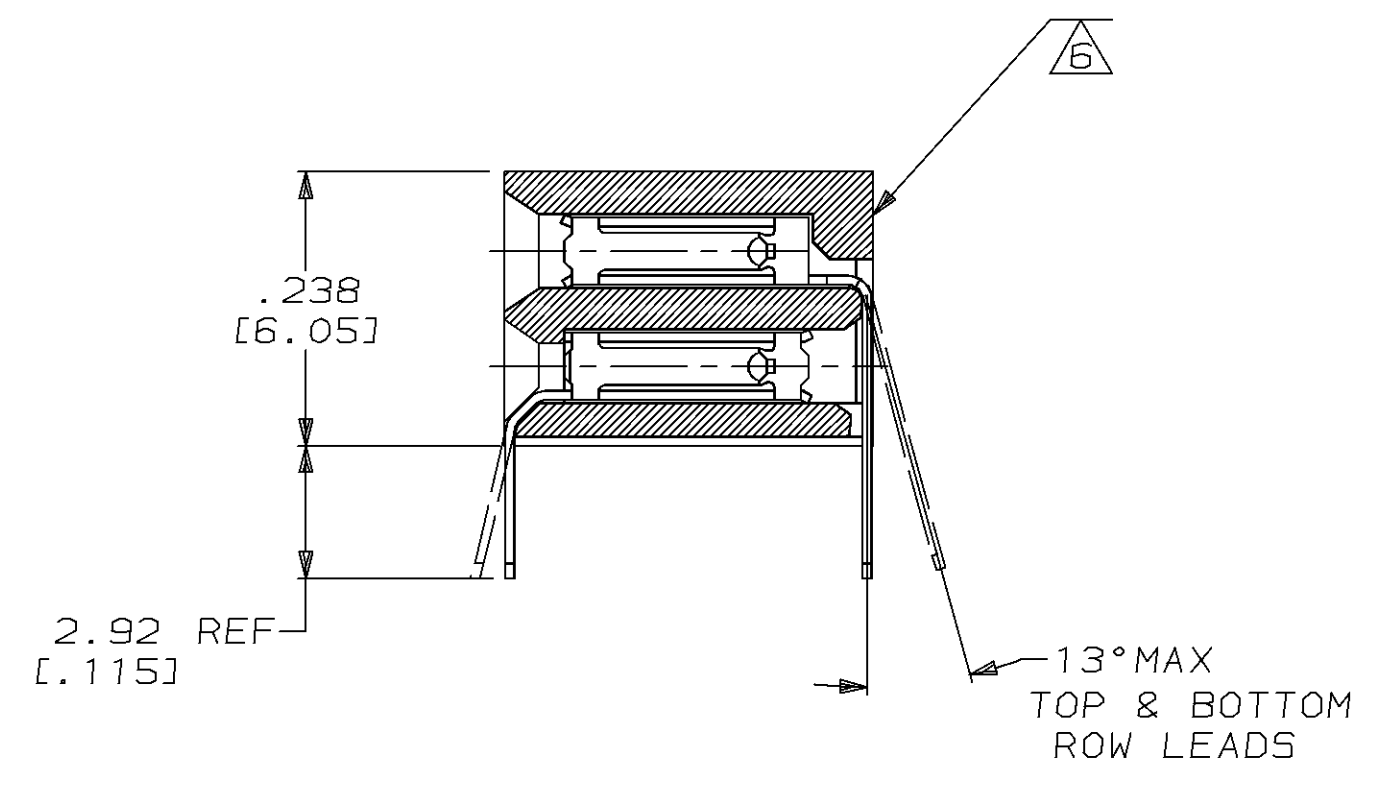
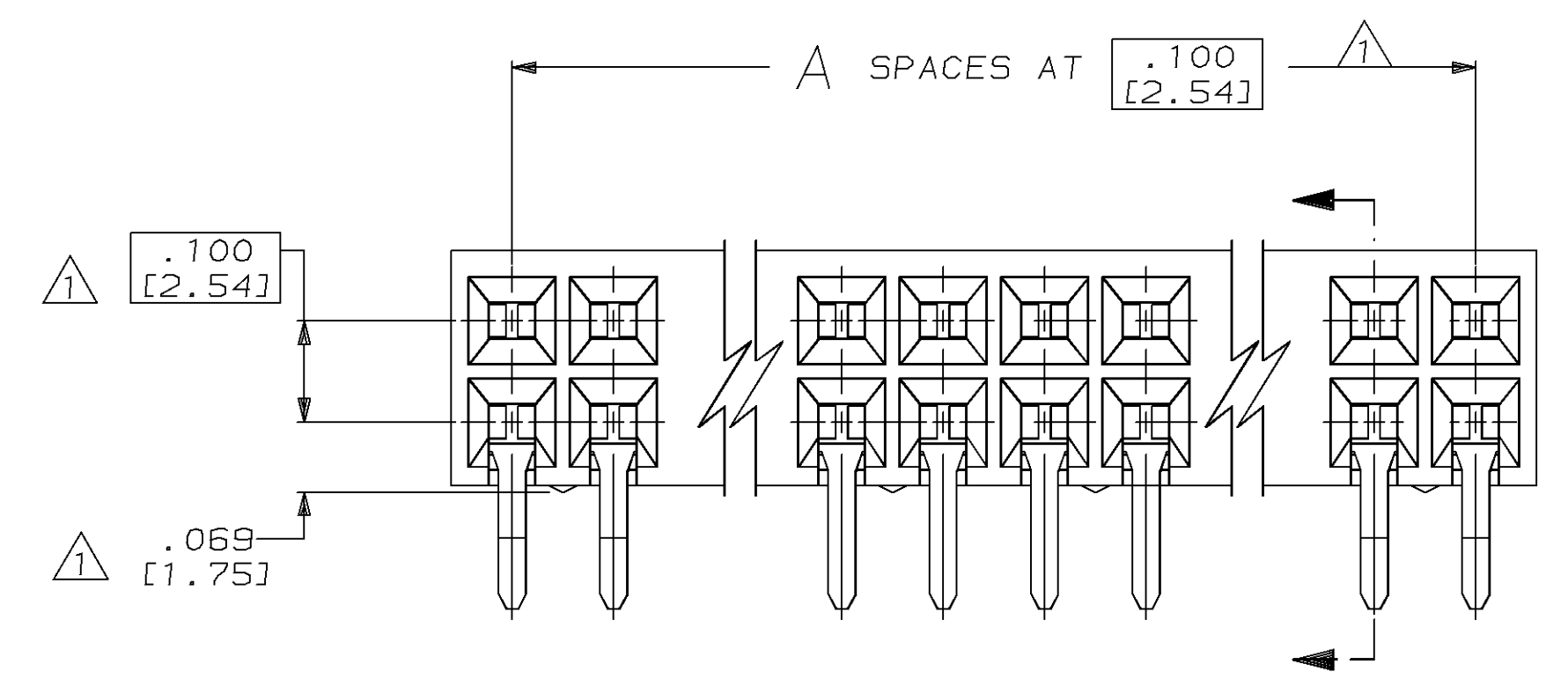
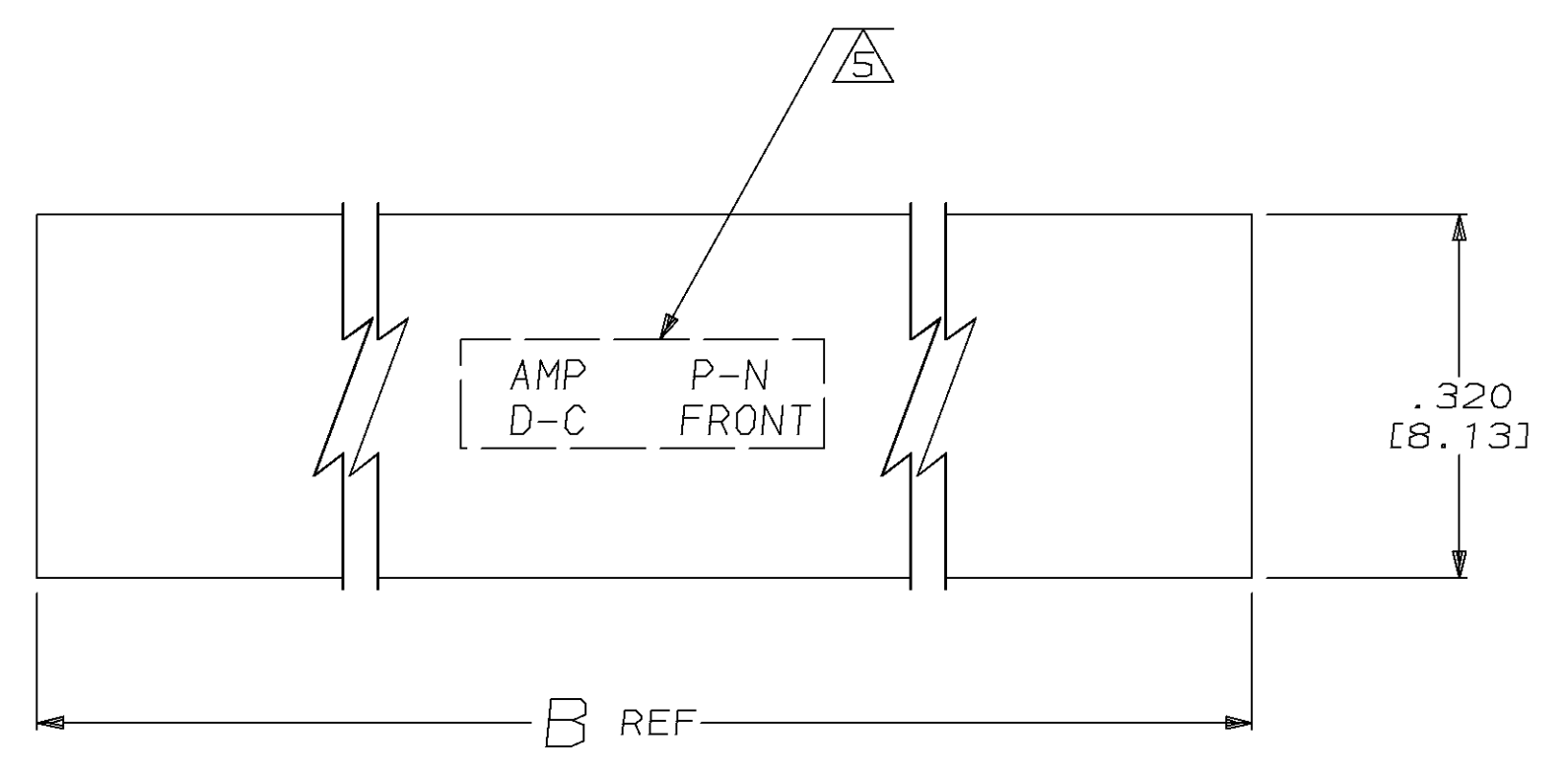

DIMENSIONS		TOLERANCES UNLESS OTHERWISE SPECIFIED		DWN		CHK		APVD		NAME	
0	PLC	±	-	T. ALEXANDER	10-4-94	G. GRIFFITH	10-4-94	G. GRIFFITH	10-4-94	AMP	AMP Incorporated
1	PLC	±	-							Harrisburg, PA 17105-3608	
2	PLC	±	0.005 [0.13]							AMP MOD II RCPT ASSEMBLY	
3	PLC	±	-							DOUBLE ROW, .100¢	
4	PLC	±	-							SIZE	
MATERIAL		FINISH		WEIGHT		CAGE CODE		DRAWING NO		SCALE	
HOUSING: △		CONTACTS: △		.11 GRAM/CONTACT #5X		A1 00779		C-443042		6:1	
CONTACTS: △		CONTACTS: △		CUSTOMER DRAWING						SHEET 1 OF 1 REV 0	