

DESIGN OBJECTIVES

The product described in this document has not been fully tested to ensure conformance to the requirements outlined below. Therefore, Tyco Electronics AMP K.K. makes no representation or warranty, express or implied, that product will comply with these requirements. Further, Tyco Electronics AMP K.K. may change these requirements based on the results of additional testing and evaluation. Contact AMP Engineering for further details.

In case when "product specification" is referred to in this document, it should be read as "design objectives" for all times as applicable.

1. Scope:**1.1 Contents**

This specification covers the requirements for product performance, test methods and quality assurance provisions of SQUIB 11DIA Short Circuit Ring.

Applicable product description and part numbers are as shown in Appendix 1.

2. Applicable Documents:

The following documents form a part of this specification to the extent specified herein. In the event of conflict between the requirements of this specification and the product drawing, the product drawing shall take precedence. In the event of conflict between the requirements of this specification and the referenced documents, this specification shall take precedence.

2.1 AMP Specifications:

- A. 109-5000 : Test Specification, General Requirements for Test Methods
- B. 501- : Qualification Test Report of SQUIB 11DIA Short Circuit Ring

2.2 Commercial Standards and Specifications

- A. JASO D605 : Multi-pole Connector for automobiles
- B. JASO D7101 : Test Methods for Plastic Molded Parts
- C. JIS C3406 : Low-Voltage Wires and Cables for Automobiles
- D. JIS D0204 : Method of High and Low Temperature Test for Automobile Parts

3. Requirements:

3.1 Design and Construction:

Product shall be of the design, construction and physical dimensions specified on the applicable product drawing.

3.2 Material:

A. Contact:

Description	Material	Finish
Shorting Clip	Copper Alloy	Selective Gold plating over Ni under plating

Fig.1

B. Housing : PBT

3.3 Ratings:

A.: Temperature Rating : -30°C to 80°C

3.4 Performance Requirements and Test Descriptions:

The product shall be designed to meet the electrical, mechanical and environmental performance requirements specified in Fig.2 and Fig.3.

All tests shall be performed in the room temperature, unless otherwise specified.

The interface for test shall be met the customer-drawing.

3.5 Test Requirements and Procedures Summary:

Para.	Test Items	Requirements	Procedures
3.5.1	Confirmation of Product	Meet requirements of product drawing.	Visually, dimensionally and functionally inspected per applicable quality inspection plan.
Physical Requirements			
3.5.2	Handling Ergonomics	No abnormalities allowed in manual mating/unmating handling.	Manually operated.
Electrical Requirements			
3.5.3	Termination Resistance (Low Level)	50 mΩ Max.(Initial) 100m Ω Max.(Final)	Between the Squib Pins (Shorting Clip is included) to 20±5mV Max. Open circuit at 10±0.5mA. Fig.4 AMP Spec. 109-5311-1

Fig.2(To be continued)

Para.	Test Items	Requirements	Procedures
Environmental Requirements			
3.5.4	Industrial Gas(SO ₂)	Satisfy requirements of test item on the "3.6 sequence"	Mated connector. SO ₂ Gas: 25ppm, 75%R.H. 20°C, 96 hours
3.5.5	Temperature Life (Heat Aging)	Satisfy requirements of test item on the "3.6 sequence"	Mated connector. 120°C, 300hours

Fig.2(End)

3.6 Product Qualification Test Sequence

Test Examination	Test Group		
	1	2	3
	Test Sequence*		
Examination of Product	1	1,4	1,4
Handling Ergonomics	2		
Termination Resistance (Low Level)	3	2,5	2,5
Industrial SO ₂ Gas		3	
Temperature Life (Heat Aging)			3

* Numbers indicate sequence in which tests are performed.

Fig. 3

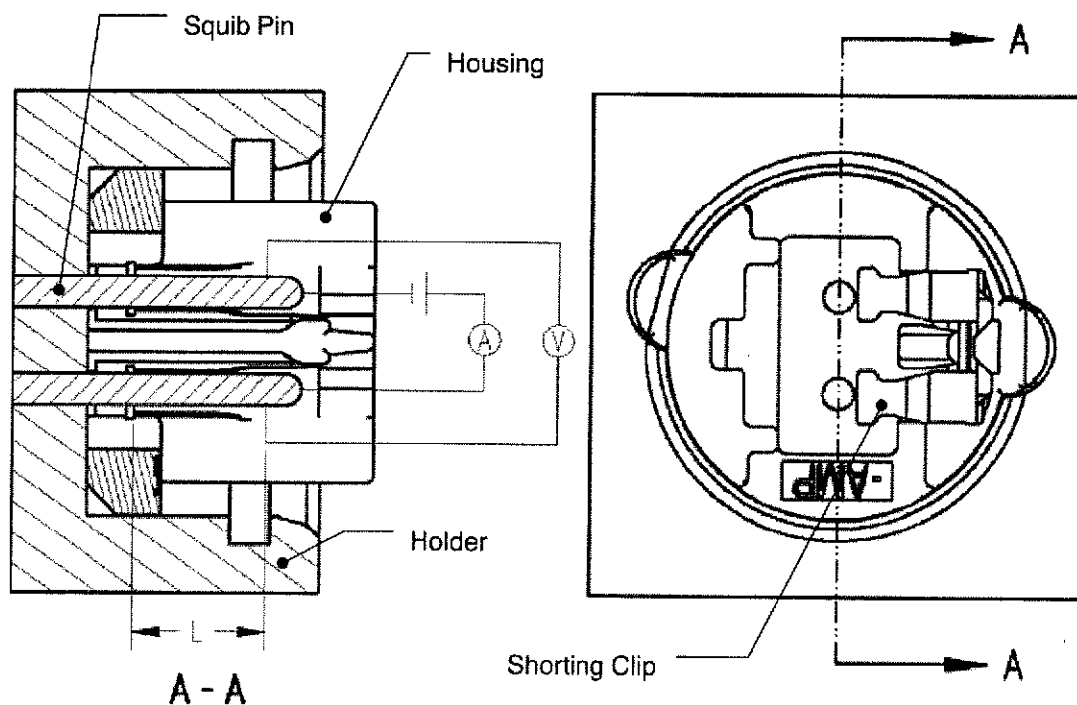

Deduct the resistance of the wire "L" from the measured value.

Fig.4

The applicable product descriptions and part numbers are as shown in Appendix. 1

Product Part No. *	Description
1376766	SQUIB 11DIA SHORT CIRCUIT RING 9.3mm TYPE
1473369	SQUIB 11DIA SHORT CIRCUIT RING 8.8mm TYPE WITH FLANGE
1565765	SQUIB 11DIA SHORT CIRCUIT RING 8.5mm TYPE

Appendix. 1

*Note: Part number is consisted from listed base number and 1 digit numeric prefix and Suffix with dash. Refer to catalog or customer drawing for specific part numbers for each base number. When prefix is zero, zero and dash are omitted.