



Electronics

Tyco Electronics Corporation 300 Constitutional Drive Menlo Park, CA 94025 USA DCR #: T-13866	Raychem	No: D-6021 Rev: A Date: February 12, 1990 Page: 1 of 15
--	----------------	---

MIL-STD-1553B Multiplex DataBus Box Couplers and Terminators Connectorized with D-6025 Connector Interface

1.0 Introduction

1.1 Scope

This specification covers the Raychem D-500-0255 series of MIL-STD-1553B multiplex data bus box couplers and D-621-XXXX series of MIL-STD-1553B terminators.

1.2 Description

Items covered by this specification are non-repairable components installed as parts of a data bus system. They provide intrinsic EMI shielding.

1.3 Classification

These items are classified (solely dependent upon the connector interface type and environmental resistance) as follows:

- a. Connector Type: Threaded connector type
Bayonet connector type
- b. Environmental Resistance of Connector:
General purpose (terminators only)
Environment resistant
Environment resistant, 1000 hour salt spray

1.4 Intended Use

Data bus box couplers covered by this specification provide fault isolation by series resistance and transformer coupling between the bus cables and stub cables in accordance with MIL-STD-1553B. Data bus terminators covered by this specification provide matched impedance bus termination or stub termination with a resistive load simulating a remote terminal (RT). These products may be used in applications within the operating temperature range of -55°C to +125°C.

2.0 Applicable Documents

2.1 Issues of Documents

The following documents, of the issue in effect on date of order or request for proposal, form a part of this specification to the extent specified herein. However, this specification takes precedence over the referenced documents.



Electronics

Tyco Electronics Corporation 300 Constitutional Drive Menlo Park, CA 94025 USA DCR #: T-13866	Raychem	No: D-6021 Rev: A Date: February 12, 1990 Page: 2 of 15
--	----------------	--

2.2 Department of Defense Specifications

Military

- MIL-T-21038 Transformers, Pulse, Low Power
- MIL-R-39007 Resistors, Fixed, Wire-Wound (Power Type), Established Reliability General Specification for
- MIL-R-55182 Resistors, Fixed, Film, Established Reliability
- MIL-C-85485 Cable, Electric, Filter Line, Radio Frequency Absorptive

Federal

- QQ-S-571 Solder: Tin Alloy; Tin-Lead Alloy; and Lead Alloy

Specifications

Military

- MIL-STD-105 Sampling Procedures and Tables for Inspection by Attributes
- MIL-STD-129 Marking for Shipment and Storage

- MIL-STD-130 Identification Marking of U.S. Military Property
- MIL-STD-202 Test Methods for Electronic and Electrical Component Parts
- MIL-STD-454 Standard General Requirements for Electronic Equipment
- MIL-STD-810 Environmental Test Methods and Engineering Guidelines
- MIL-STD-1344 Test Methods for Electrical Connectors
- MIL-STD-1553B Aircraft Internal Time Division Command/Response Multiplex Data Bus
- MIL-STD-45662 Calibration Systems Requirements

(Copies of Department of Defense documents may be obtained from the Naval Publications and Forms Center, 5801 Tabor Avenue, Philadelphia, PA 19120-5099.)

4.5 Raychem Corporation

- D-6025 D-621 Series Connectors for Coaxial, Triaxial and Twinaxial cables

(Copies of Raychem documents may be obtained from Raychem Corporation, 300 Constitution Drive, Menlo Park, CA 94025.)

3.0 Requirements

3.1 Specification Control Drawings

The requirements for individual items under this specification shall be as specified herein and in the applicable specification control drawing. In the event of conflict between the requirements of this specification and those of the specification control drawing (SCD), the latter shall govern.



Electronics

Tyco Electronics Corporation 300 Constitutional Drive Menlo Park, CA 94025 USA DCR #: T-13866	Raychem	No: D-6021 Rev: A Date: February 12, 1990 Page: 3 of 15
--	----------------	---

3.2 Classification of Requirements

The requirements for these products are classified herein as follows:

Requirement	Paragraph
Qualification	3.3
Materials	3.4
Design and Construction	3.5
Performance	3.6
Identification	3.7
Workmanship	3.8

3.3 Qualification

Items furnished under this specification or listed on Qualified Products List D-6021-QPL shall be products which are qualified to this specification.

3.4 Materials Requirements

All materials used in the manufacture of these products shall be of the quality and form best suited for the purpose intended. All materials used shall conform to the requirements specified herein.

3.4.1 Dissimilar Metals

When dissimilar metals are used in intimate contact with each other, protection against electrolytic corrosion shall be provided as specified in MIL-STD-454, Requirement 16.

3.4.2 Component Materials

Materials for specific components of these items shall be as follows:

- a. Isolation transformer--Per MIL-STD-1553B and MIL-T-21038
- b. Resistors--Per MIL-STD-1553B, and MIL-R-55182 or MIL-R-39007
- c. Box coupler housing--Aluminum alloy
- d. Terminator housing--Stainless steel
- e. Solder--QQ-S-571
- f. Connectors--Per Raychem Specification D-6025 and the applicable specification control drawing.



Electronics

Tyco Electronics Corporation 300 Constitutional Drive Menlo Park, CA 94025 USA DCR #: T-13866	Raychem	No: D-6021 Rev: A Date: February 12, 1990 Page: 4 of 15
--	----------------	---

3.5 Design and Construction Requirements

These items are designed to be nonrepairable components which are connectorized for inclusion in data bus harnesses. They shall consist of encapsulated electrical components within an EMI shielded housing. Box couplers consist of encapsulated transformer/resistor modules, and terminators consist of encapsulated resistors.

3.5.1 Weight, Configuration and Dimensions

Weight, configuration and dimensions of couplers and terminators shall be as shown in the applicable specification control drawings.

3.5.2 Interchangeability

All items having the same part number shall be completely interchangeable with each other in regard to installation and performance.

3.6 Performance Requirements

When tested in accordance with the procedures defined in 4.5, couplers and terminators shall conform to the requirements specified herein and in the applicable specification control drawing. Tests marked with an asterisk (*) are not applicable to general, purpose terminators (see 1.3).

3.6.1 Functional Tests

3.6.1.1 Transformer/Resistor Module Requirements. Transformer/resistor modules and their component elements shall meet the requirements of MIL-STD- 1553B.

3.6.1.2 Box Coupler Input Impedance. When box couplers are tested as specified in 4.5.3.1, the input impedance shall be 3000 -* (number of stubs) ohms, minimum over the temperature range specified.

4.5.19.1 Box Coupler Waveform Integrity Test

When single stub box couplers are tested as specified in 4.5.3.2, the droop of the waveform on the bus leads shall not exceed 20 percent. Overshoot and ringing shall be less than ± 1.0 volt peak.

4.5.19.2 Box Coupler Maximum Voltage Test

When a box coupler is tested as specified in 4.5.3.3, the voltage on the coupler's bus cables shall be between 8 and 10 V p-p.

4.5.19.3 Box Coupler Minimum Voltage Test

When a box coupler is tested as specified in 4.5.3.4, the voltage on the coupler's bus cables shall be between 5 and 7 V p-p.



Electronics

Tyco Electronics Corporation 300 Constitutional Drive Menlo Park, CA 94025 USA DCR #: T-13866	Raychem	No: D-6021 Rev: A Date: February 12, 1990 Page: 5 of 15
--	----------------	---

4.5.19.4 Terminator Resistance Test

When a terminator is tested as specified in 4.5.3.5, the measured DC resistance of the resistor shall meet the requirements of the applicable specification control drawing.

4.5.19.5 Transmission Test

When box couplers and terminators are tested as specified in 4.5.3.6, there shall be no word errors detected during functional operation.

4.5.20 Insulation Resistance

When specimens are tested as specified in 4.5.4, the insulation resistance between each conductor and the enclosure shall be 100 megohms minimum.

4.5.21 Dielectric Strength

When specimens are tested as specified in 4.5.5, there shall be no arcing or breakdown between each conductor and the enclosure. The leakage current shall be 2 milliamperes maximum.

4.5.22 Temperature Shock

When tested as specified in 4.5.6, specimens shall function normally during the test, and there shall be no evidence of damage detrimental to performance.

3.6.5 Temperature Altitude

When tested as specified in 4.5.7, specimens shall function normally during the test, and there shall be no evidence of damage detrimental to performance.

3.6.6 Altitude Immersion*

When tested as specified in 4.5.8, specimens shall meet the insulation resistance requirement of 3.6.2, and there shall be no evidence of damage detrimental to performance.

3.6.7 Moisture Resistance*

When tested as specified in 4.5.9, specimens shall meet the insulation resistance requirement of 3.6.2, and there shall be no evidence of damage detrimental to performance.

3.6.8 Rain*

When tested as specified in 4.5.10, specimens shall function normally during the test, and there shall be no evidence of damage detrimental to performance.

3.6.9 Salt Spray*

When tested as specified in 4.5.11, specimens shall function normally during the test, and there shall be no evidence of damage detrimental to performance.



Electronics

Tyco Electronics Corporation 300 Constitutional Drive Menlo Park, CA 94025 USA DCR #: T-13866	Raychem	No: D-6021 Rev: A Date: February 12, 1990 Page: 6 of 15
--	----------------	---

- 3.6.10 Sinusoidal Vibration. When tested as specified in 4.5.12, specimens shall function normally during the test, and there shall be no evidence of damage detrimental to performance.
- 3.6.11 Random Vibration. When tested as specified in 4.5.13, specimens shall function normally during the test, and there shall be no evidence of damage detrimental to performance.
- 3.6.12 Mechanical Shock. When tested as specified in 4.5.14, specimens shall function normally during the test, and there shall be no evidence of damage detrimental to performance.
- 3.6.13 Dust (Fine Sand)*. When tested as specified in 4.5.15, specimens shall function normally during the test, and there shall be no evidence of damage detrimental to performance.
- 3.6.14 Humidity*. When tested as specified in 4.5.16, specimens shall function normally during the test, and there shall be no evidence of damage detrimental to performance.
- 3.6.15 Fluids Resistance*. When tested as specified in 4.5.17, specimens shall meet the insulation resistance requirement of 3.6.2, and there shall be no evidence of damage detrimental to performance.
- 3.6.16 EMI Shielding Effectiveness. When specimens are tested as specified in 4.5.18, the surface transfer impedance shall not exceed 14 milliohms per meter over the frequency range 1 MHz to 30 MHz.
- 3.6.17 Post Test Examination. When visually examined as specified in 4.5.19, specimens shall not show any evidence of damage detrimental to performance.
- 3.7 Product Identification
The minimal information on the label shall be the part number, the description, "Raychem", and the FSCM code. All marking shall be in accordance with MIL-STD-130 and shall remain legible after completion of the tests specified herein.
- 3.8 Workmanship
Box couplers and terminators shall be processed in such a manner as to be consistent in quality; they shall be free from defects that would adversely affect life, performance or appearance.
- 4.0 Quality Assurance Provisions**
 - 4.1 Responsibility for Inspection. The supplier is responsible for the performance of all inspection tests specified herein. The supplier may utilize his own or any other suitable testing facility. Inspection records of the tests shall be kept complete and available to the buyer as specified in the contract or order.



Electronics

Tyco Electronics Corporation 300 Constitutional Drive Menlo Park, CA 94025 USA DCR #: T-13866	Raychem	No: D-6021 Rev: A Date: February 12, 1990 Page: 7 of 15
--	----------------	---

- 4.1.1 Test Equipment and Inspection Facilities. Test and measuring equipment and inspection facilities of sufficient accuracy, quality, and quantity to permit performance of the required inspection shall be established and maintained by the supplier. A calibration system to control the accuracy of the measuring and test equipment shall be maintained in accordance with MIL-STD- 45662.

- 4.2 Classification of Inspections. The examination and testing of items covered by this specification shall be classified as follows:
 - a. Qualification inspection (See para. 4.3)
 - b. Acceptance inspection (See para. 4.4)

- 4.3 Qualification Inspection. Qualification inspection shall consist of all of the tests in Table I performed in the order of listing.

- 4.3.1 Qualification Test Samples. Test samples submitted for qualification shall be produced using equipment and procedures normally used in production. Test samples shall be interconnected with MIL-STD-1553B data bus cable into data bus networks in order that correct function of the components can be verified during environmental exposure. Mating connectors shall be torqued to the specified value and of the same environment resistance and finish as those on the components under test.



Electronics

Tyco Electronics Corporation 300 Constitutional Drive Menlo Park, CA 94025 USA DCR #: T-13866	Raychem	No: D-6021 Rev: A Date: February 12, 1990 Page: 8 of 15
--	----------------	--

Table I. Qualification Inspection

Test Group 1

Test Sequence	Requirement Paragraph	Procedure Paragraph
Visual examination	3.1, 3.4, 3.5, 3.7, 3.8	4.5.2
Functional tests	3.6.1	4.5.3
Insulation resistance	3.6.2	4.5.4
Dielectric strength	3.6.3	4.5.5
EMI shielding effectiveness	3.6.16	4.5.18
Temperature sock	3.6.4	4.5.6
Temperature altitude	3.6.5	4.5.7
Sinusoidal vibration	3.6.10	4.5.12
Random vibration	3.6.11	4.5.13
Mechanical shock	3.6.12	4.5.14
Dust (fine sand)*	3.6.13	4.5.15
Humidity*	3.6.14	4.5.16
Insulation resistance	3.6.2	4.5.4
Dielectric strength	3.6.3	4.5.5
Functional tests	3.6.1	4.5.3
Post test examination	3.6.17	4.5.19

* Environment resistant types only.

Test Group 2

Test Sequence	Requirement Paragraph	Procedure Paragraph
Visual examination	3.1, 3.4, 3.5, 3.7, 3.8	4.5.2
Functional tests	3.6.1	4.5.3
Insulation resistance	3.6.2	4.5.4
Dielectric resistance	3.6.3	4.5.5
EMI shielding effectiveness	3.6.16	4.5.18
Rain*	3.6.8	4.5.10
Salt spray*	3.6.9	4.5.11
Altitude immersion*	3.6.6	4.5.8
Insulation resistance	3.6.2	4.5.4
Dielectric strength	3.6.3	4.5.5
Functional tests	3.6.1	4.5.3
Post test examination	3.6.17	4.5.19

* Environment resistant types only



Electronics

Tyco Electronics Corporation 300 Constitutional Drive Menlo Park, CA 94025 USA DCR #: T-13866	Raychem	No: D-6021 Rev: A Date: February 12, 1990 Page: 9 of 15
--	----------------	--

Test Group 3

Test Sequence	Requirement Paragraph	Procedure Paragraph
Visual examination	3.1, 3.4, 3.5, 3.7, 3.8	4.5.2
Fluids resistance*	3.6.15	4.5.17
Insulation resistance	3.6.2	4.5.4
Dielectric strength	3.6.3	4.5.5
Post test examination	3.6.17	4.5.19

* Environment resistance types only.

4.4 Acceptance Inspection. Lot acceptance inspection shall consist of the tests listed in Table II. Acceptance inspection shall be performed on every lot of items manufactured under this specification. In process examination may be used for acceptance inspection.

Table II Acceptance Inspection

Test	Requirement Paragraph	Procedure Paragraph	Inspection Level*	AQL*
Visual examination	3.1, 3.4, 3.5, 3.7, 3.8	4.5.2	II	1%
Waveform integrity	3.6.1.3	4.5.3.2	100%	--
Coupler maximum voltage	3.6.1.4	4.5.3.3	100%	--
Coupler minimum voltage	3.6.1.5	4.5.3.4	100%	--
Termination resistance	3.6.1.6	4.5.3.5	100%	--
Insulation Resistance	3.6.2	4.5.4	100%	--

* Inspection Level and AQL per MIL-STD-105.

4.4.1 Rejected Lots. If an inspection lot is rejected, the lot shall be replaced, or the defective units shall be reworked to correct the defect or screened out. If the lot is reworked or the defective units are screened out, the lot shall be resubmitted for inspection. Resubmitted lots shall be inspected using tightened inspection in accordance with MIL-STD-105. Before resubmitting, full particulars concerning the rejection and the action taken to correct the defect shall be recorded.

4.4.2 Examination of Preparation for Delivery. Preparation for delivery of material ready for shipment shall be examined to determine compliance with the requirements of Section 5.

4.5 Test Procedures

4.5.1 Test Conditions. Unless otherwise specified, all tests shall be performed at ambient temperature, pressure, and relative humidity as specified in the general requirements of MIL-STD-202. Tolerances for test conditions shall meet the general requirements of MIL-STD-202 and MIL-STD-810.

4.5.2 Visual Examination. Specimens shall be visually examined to ensure conformance with 3.1, 3.4, and 3.5 of this specification.

4.5.3 Functional Tests

4.5.3.1 Box Coupler Input Impedance (see 3.6.1.2). Input impedance shall be measured as described in MIL-STD-1553B at room temperature and at the temperature rating extremes.

4.5.3.2 Box Coupler Waveform Integrity Test (see 3.6.1.3) Box couplers shall be tested using the test configuration shown in Figure 1. The maximum terminal output voltage of 27 V p-p shall be applied at point A using the waveform specified in MIL-STD-1553B, paragraph 4.5.1.5.1.1.2 (250 kHz frequency). Droop, overshoot and ringing shall be measured on the bus leads at point B.

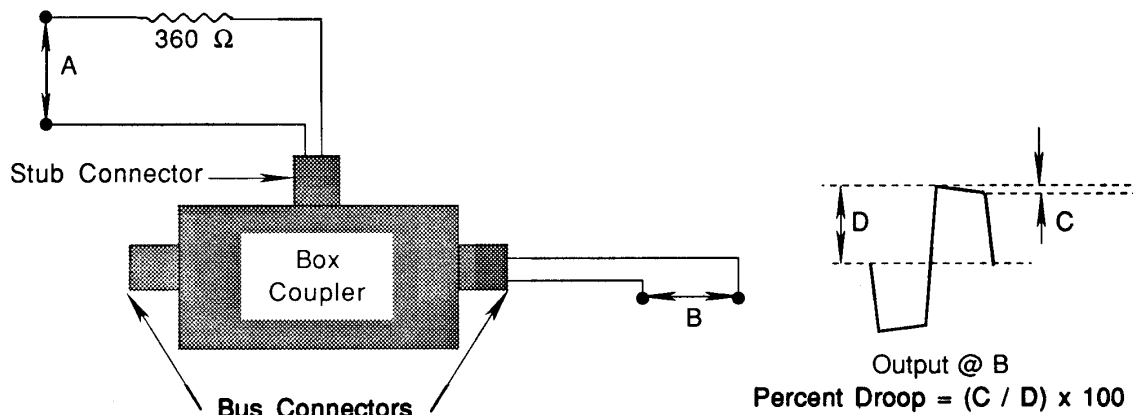

Figure 1 Box Coupler Waveform Integrity Test

4.5.3.3 Box Coupler Maximum Voltage Test (see 3.6.1.4). Box couplers shall be tested using the test configurations shown in Figures 2 and 3, respectively. The maximum terminal output voltage of 27 V p-p shall be applied at V1 using the 250 kHz waveform described in 4.5.3.2. The output voltage shall be measured at V2. This test shall then be repeated using a 1 MHz waveform similar to that described in 4.5.3.2.

Tyco Electronics Corporation 300 Constitutional Drive Menlo Park, CA 94025 USA DCR #: T-13866	Raychem	No: D-6021 Rev: A Date: February 12, 1990 Page: 11 of 15
--	----------------	---

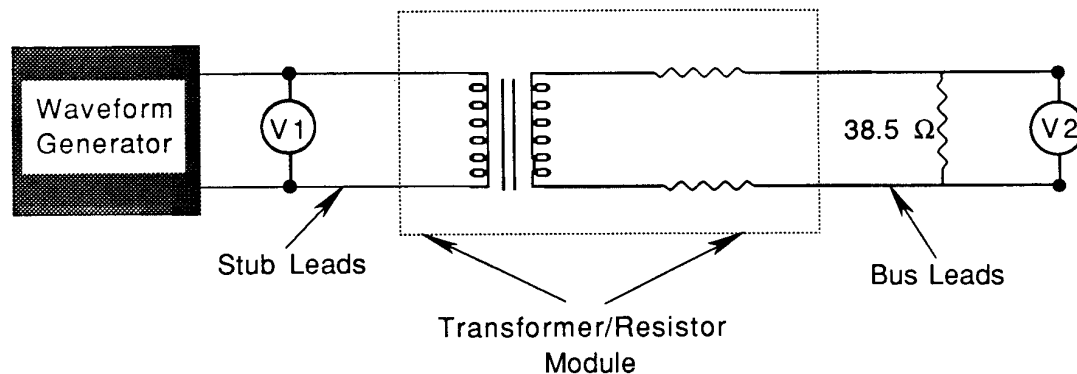

Figure 2. Module Voltage Tests

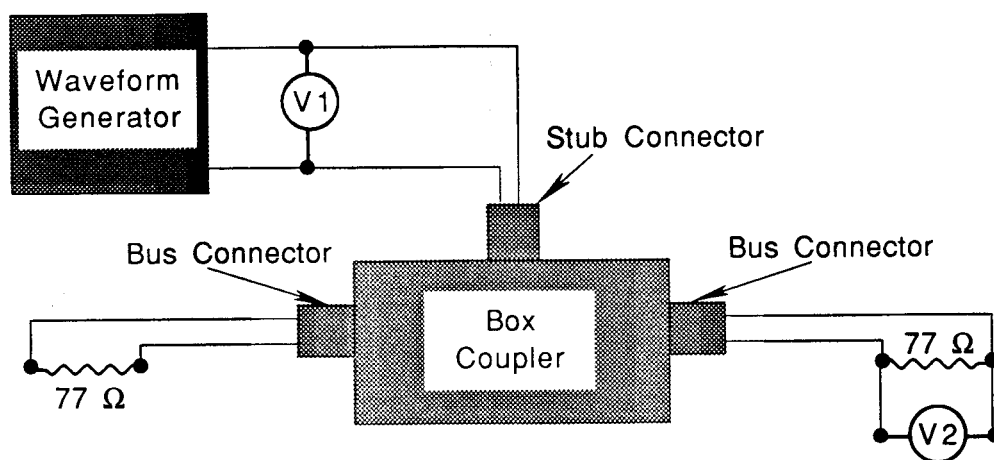

Figure 3. Box Coupler Voltage Tests

- 4.5.3.4 Box Coupler Minimum Voltage Test (see 3.6.1.5). Box couplers shall be tested using the test configurations shown in Figures 2 and 3, respectively. The minimum terminal output voltage of 18 V p-p shall be applied at V1 using the 250 kHz waveform described in 4.5.3.2. The output voltage shall be measured at V2. This test shall then be repeated using a 1 MHz waveform described in 4.5.3.2.
- 4.5.3.5 Terminator Resistance Test (see 3.6.1.6). The DC resistance of the terminator shall be measured in accordance with MIL-STD-202, Method 303.
- 4.5.3.6 Transmission Test (see 3.6.1.7). MIL-STD-1553B words shall be transmitted over a network composed of box couplers and terminators interconnected with suitable data bus cable. The transmitter output shall be 18 V p-p with a 300-nanosecond rise time. A special terminal equipped with counters shall be used to count the number of correct words and error words received during the test.



Electronics

Tyco Electronics Corporation 300 Constitutional Drive Menlo Park, CA 94025 USA DCR #: T-13866	Raychem	No: D-6021 Rev: A Date: February 12, 1990 Page: 12 of 15
--	----------------	--

- 4.5.4 Insulation Resistance (see 3.6.2). Specimens shall be tested in accordance with MIL-STD-202, Method 302, Test Condition B (500 Vdc). Insulation resistance shall be measured between each conductor and shield of attached cables.
- 4.5.5 Dielectric Strength (see 3.6.3). Specimens shall be tested in accordance with MIL-STD-202, Method 301, using 500 Vac, 60 Hz. The test voltage shall be applied for 1 minute between each conductor and shield of attached cables. Leakage current shall be recorded.
- 4.5.6 Temperature Shock (see 3.6.4). Specimens shall be tested in accordance with MIL-STD-202, Method 107, Test Condition B, except that the low temperature shall be -55°C, the dwell time shall be 4 hours and the number of cycles 3. During this test, the specimens shall be subjected to the transmission test of 4.5.3.6.
- 4.5.7 Temperature-Altitude (see 3.6.5). Specimens shall be exposed to the temperature-altitude conditions shown in Table III. During this test, except for Step 1, the specimens shall be subjected to the transmission test of 4.5.3.6.

Table III. Temperature Altitude Conditioning

Step	Temperature (°C)	Altitude (ft)	Duration (hrs)
1	-65	Site	2.0
2	-54	Site	*
3	-54	70,000	*
4	-10	Site	*
5	95	Site	16.0
6	71	Site	4.0
7	95	Site	0.5
8	36	50,000	4.0
9	60	50,000	0.5
10	10	70,000	4.0
11	35	70,000	0.5

* Duration sufficient to allow temperature stabilization.



Electronics

Tyco Electronics Corporation 300 Constitutional Drive Menlo Park, CA 94025 USA DCR #: T-13866	Raychem	No: D-6021 Rev: A Date: February 12, 1990 Page: 13 of 15
--	----------------	--

- 4.5.8 Altitude Immersion (see 3.6.6). The specimens shall be tested in accordance with MIL-STD-1344, Method 1004.1, omitting Paragraph 4.3. At least one foot of cable attached to the mating connectors shall not be immersed in the water bath.
- 4.5.9 Moisture Resistance (see 3.6.7). The specimens shall be tested in accordance with MIL-STD-202, Method 106, omitting Step 7b and Paragraph 3.6. At the end of the test, while the specimens are still in high humidity, they shall be subjected to the transmission test of 4.5.3.6.
- 4.5.10 Rain (see 3.6.8). Specimens shall be tested in accordance with MIL-STD-810, Method 506, Procedure I. The test conditions shall be as shown in Table IV. The test shall be conducted with rain impinging at 45 degrees upon the front, back and end faces of the box couplers. During this test, the specimens shall be subjected to the transmission test of 4.5.3.6.

Table IV. Rain Test Conditions

Step	Step Duration (min)	Wind Velocity (mph)	Rainfall Rate (inch/hr)
1	5	0	2
2	5	40	2
3	5	40	2
4	5	40	2
5	10	0	2

- 4.5.11 Salt Spray (see 3.6.9). Specimens shall be tested in accordance with MIL-STD-26-2, Method 101, except, the exposure time shall be 48 hours for environment resistant components and 1000 hours for components with 1000 hour salt spray finish. During the last day of the test the specimens shall be subjected to the transmission test of 4.5.3.6.
- 4.5.12 Sinusoidal Vibration (see 3.6.10). Specimens shall be tested in accordance with MIL-STD-202, Method 201, except the frequency range shall be 5 to 50 Hz. During this test, the specimens shall be subjected to the transmission test of 4.5.3.6.
- 4.5.13 Random Vibration (see 3.6.11). Specimens shall be tested in accordance with MIL-STD-202, Method 214, Test Condition II, Test Letter G, for 8 hours in each of three mutually perpendicular directions. During this test, the specimens shall be subjected to the transmission test of 4.5.3.6.
- 4.5.14 Mechanical Shock (see 3.6.12). Specimens shall be tested in accordance with MIL-STD-202, Method 213, Test Condition A. During this test the specimens shall be subjected to the transmission test of 4.5.3.6.



Electronics

Tyco Electronics Corporation 300 Constitutional Drive Menlo Park, CA 94025 USA DCR #: T-13866	Raychem	No: D-6021 Rev: A Date: February 12, 1990 Page: 14 of 15
--	----------------	--

- 4.5.15 Dust (Fine Sand) (see 3.6.13). Specimens shall be tested in accordance with MIL-STD-202, Method 110. During this test the specimens shall be subjected to the transmission test of 4.5.3.6.
- 4.5.16 Humidity (see 3.6.14). Specimens shall be tested in accordance with MIL-STD-1344, Method 1002, Type III. The specimens shall be subjected to the transmission test of 4.5.3.6 during the last 3 cycles of the test.
- 4.5.17 Fluids Resistance (see 3.6.15). The specimen shall be subjected to the test fluids in accordance with MIL-STD-1344, Method 1016, except that Steps 4.1 and 4.4 shall be omitted.
- 4.5.18 EMI Shielding Effectiveness (see 3.6.16). Specimens shall be tested in accordance with MIL-C-85485, Paragraph 4.7.24. The box couplers shall be located at approximately the center of the test specimen, and signals shall be measured on the bus conductors. Stub connectors shall have shielded caps. The cable type shall be Raychem 10613 or equivalent.
- 4.5.19 Post Test Examination (see 3.6.17). The tested samples shall be visually examined without magnification for any evidence of damage which could impair proper functioning.
- 5.0 Preparation For Delivery**
 - 5.1 Packaging and Packing. Unless otherwise specified in the procurement document, packaging and packing shall be in accordance with commercial practice.
 - 5.2 Marking. Unless otherwise specified, packages shall be marked in accordance with MIL-STD-129.