

NOTE

All numerical values are in metric units [with U.S. customary units in brackets]. Dimensions are in millimeters [and inches]. Unless otherwise specified, dimensions have a tolerance of ± 0.13 [$\pm .005$] and angles have a tolerance of $\pm 2^\circ$. Figures and illustrations are for identification only and are not drawn to scale.

1. INTRODUCTION

This specification covers the application of Miniature Spring Socket Contacts. These requirements are applicable to the product with hand or automatic application tooling.

When corresponding with Tyco Electronics Personnel, use the terminology provided on this specification to help facilitate your inquiry for information. Basic terms and features of the socket is provided in Figure 1.

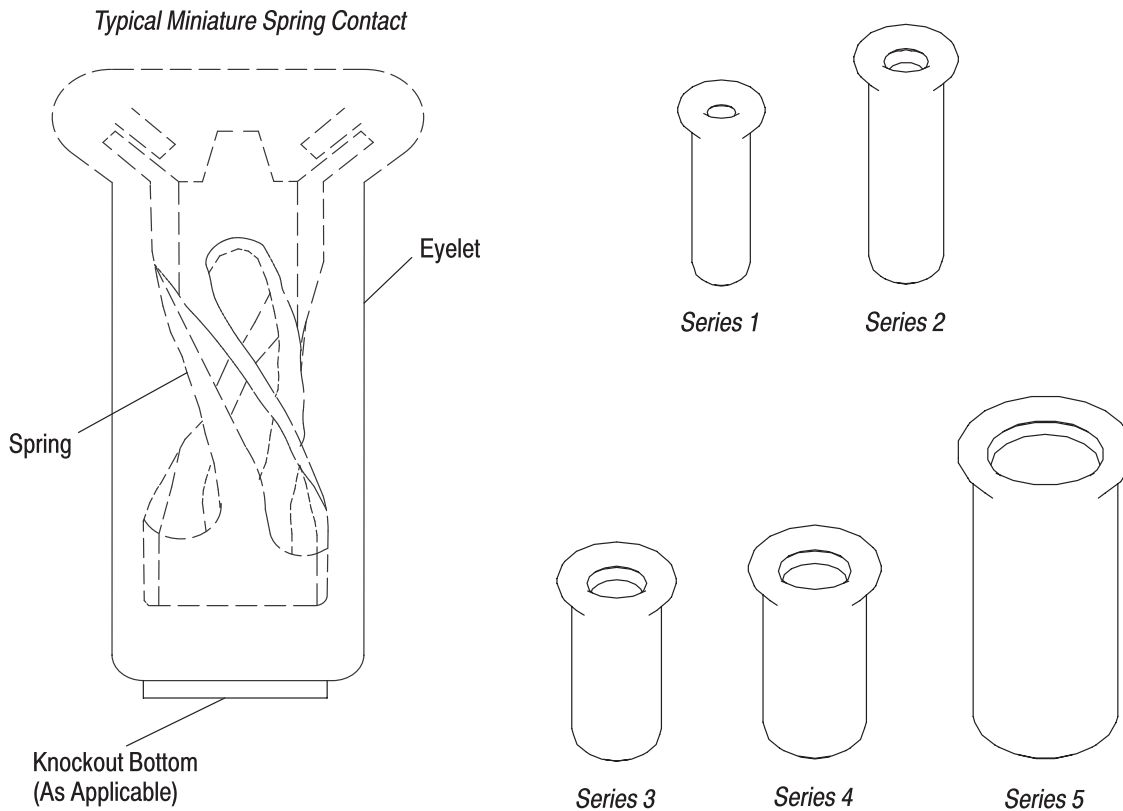

Figure 1

2. REFERENCE MATERIAL

2.1. Revision Summary

- Initial release of document

2.2. Customer Assistance

Reference Product Base Part Number 330808 and Product Code 3076 are representative numbers of Miniature Spring Socket Contacts. Use of these numbers will identify the product line and expedite your inquiries through a service network established to help you obtain product and tooling information. Such information can be obtained through a local Tyco Electronics Representative (Field Sales Engineer, Field Applications Engineer, etc) or, after purchase, by calling the Tooling Assistance Center or Product Information number at the bottom of this page.

2.3. Drawings

Customer Drawings for specific products are available from the service network. The information contained in Customer Drawings takes priority if there is a conflict with this specification or with any other technical documentation supplied by Tyco Electronics.

2.4. Manuals

Manual 402-40 is available upon request and can be used as a guide to soldering. This manual provides information on various flux types and characteristics with the commercial designation and flux removal procedures. A checklist is included in the manual as a guide for information on soldering problems.

2.5. Instructional Material

The following list includes available instruction sheets (408-series) that provide assembly procedures for operation, maintenance and repair of tooling; and customer manuals (409-series) that provide setup, operation, and maintenance of machines.

<u>Document Number</u>	<u>Document Title</u>
408-3280	Miniature Spring Socket Insertion Tool 382378-1
409-5449	Miniature Spring Socket Insertion Machines (MSSIM & SCSIM) No. 682127-[]

2.6. Specifications

Product Specification 108-14008 provides information about performance, test results, and quality requirements for the Miniature Spring Socket Contacts.

3. REQUIREMENTS

3.1. Safety

Do not stack socket contact packages so high that the shipping containers buckle or deform.

3.2. Material

The eyelet is made of copper and the spring is made of beryllium-copper. The socket contacts are available in tin or gold plate.

3.3. Storage

A. Shelf Life

The sockets should remain in the shipping containers until ready for use to prevent deformation to the contacts. The sockets should be used on a first in, first out basis to avoid storage contamination that could adversely affect performance.

B. Chemical Exposure

Do not store sockets near any chemical listed below as they may cause stress corrosion cracking in the contacts.

Alkalies	Ammonia	Citrates	Phosphates	Citrates	Sulfur Compounds
Amines	Carbonates	Nitrites	Sulfur	Nitrites	Tartrates

3.4. PC Board Requirements

A. Material and Thickness

The pc board material must be glass epoxy (FR-4 or G-10). The pc board thickness shall be 0.79-3.18 [.031-.125] thick.

NOTE

Contact the Product Information Center at the number listed at the bottom of page 1 for suitability of other board materials and thicknesses.

B. Hole Dimensions

The pc board may be single-sided or double-sided, with or without plated-thru holes. See Figure 2.

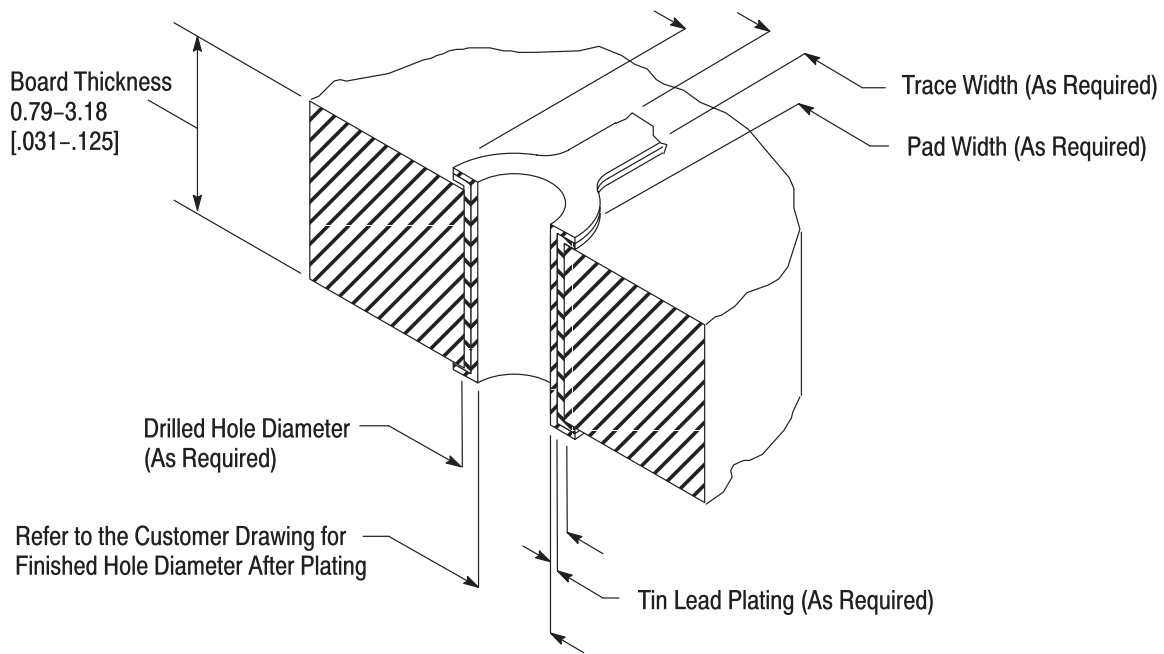

Figure 2

C. Layout (Figure 3)

For components other than Miniature Spring Socket Contacts mounted on the pc board, the clearance envelope for application tooling shall be 5.03 [.198] minimum diameter on the head side of the pc board and 2.90 [.114] minimum diameter on the other side.

For plated through holes, tin or tin-lead plating shall not exceed 0.03 [.001] to ensure minimum retention.

NOTE The pc board should be supported around the hole when inserting sockets. Refer to Instruction Sheet 408-6927.

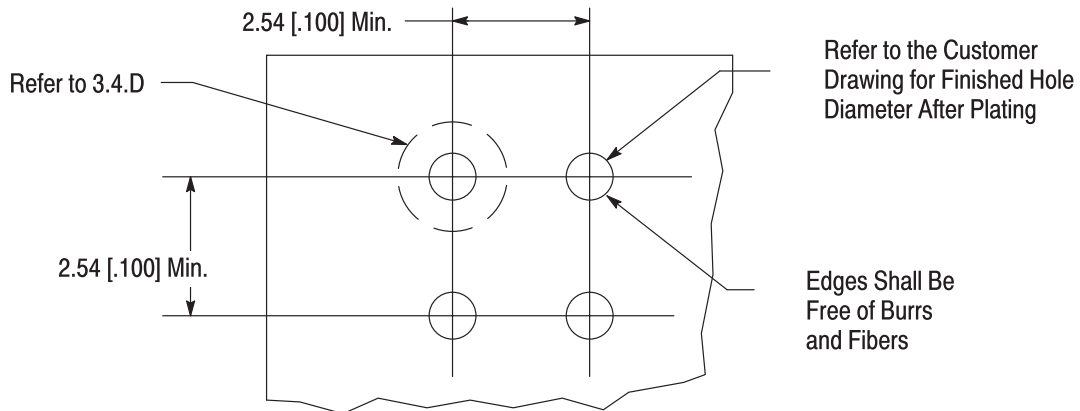

Figure 3

3.5. Insertion

Using the recommended tooling and related documentation provided in Section 5, TOOLING, insert the socket contacts into the pc board.

3.6. Soldering Socket Contacts

The Miniature Spring Socket Contacts can be soldered with wave, vapor phase, or infrared reflow processes, provided the temperatures and exposure time are within the ranges specified in Figure 4. Tyco Electronics recommends the use of SN60 or SN62 solder for the socket contacts. Refer to Paragraph 2.4 for instructional material that is available for establishing soldering guidelines.

SOLDERING PROCESS	TEMPERATURE		TIME (At Max Temperature)
	CELSIUS	FAHRENHEIT	
Wave Soldering	265°●	509°●	12 Seconds
Vapor Phase Soldering	260°	500°	3 Minutes
Infrared Reflow Soldering	260°	500°	3 Minutes

● Wave Temperature

Figure 4

A. Flux Selection

The socket contact must be fluxed prior to soldering with a mildly active, rosin base flux. Selection of the flux will depend on the type of pc board and other components mounted on the board. Additionally, the flux must be compatible with the wave solder line, manufacturing, health, and safety requirements. Call the Product Information phone number at the bottom of page 1 for consideration of other types of flux. Some fluxes that are compatible with these contacts are provided in Figure 5.

FLUX TYPE	ACTIVITY	RESIDUE	COMMERCIAL DESIGNATION	
			KESTER	ALPHA
Type RMA (Mildly Activated)	Mild	Noncorrosive	186	611

Figure 5

B. Cleaning

After soldering, removal of fluxes, residues, and activators is necessary. Consult with the supplier of the solder and flux for recommended cleaning solvents. The following is a listing of common cleaning solvents that will not affect the contacts for the time and temperature specified. See Figure 6.

DANGER

Consideration must be given to toxicity and other safety requirements recommended by the solvent manufacturer. Refer to the manufacturer's Material Safety Data Sheet (MSDS) for characteristics and handling of cleaners. Trichloroethylene and Methylene Chloride can be used with no harmful affect to the contacts; however Tyco Electronics does not recommend them because of the harmful occupational and environmental effects. Both are carcinogenic (cancer-causing) and Trichloroethylene is harmful to the earth's ozone layer.

NOTE

If you have a particular solvent that is not listed, contact the Tooling Assistance Center or Product Information number at the bottom of page 1.

CLEANER		TIME (Minutes)	TEMPERATURES (Maximum)	
NAME	TYPE		CELSIUS	FAHRENHEIT
ALPHA 2110	Aqueous	1	132	270
BIOACT EC-7	Solvent	5	100	212
Butyl CARBITOL	Solvent	1	Room Ambient	
Isopropyl Alcohol	Solvent	5	100	212
KESTER 5778	Aqueous	5	100	212
KESTER 5779	Aqueous	5	100	212
LONCOTERGE 520	Aqueous	5	100	212
LONCOTERGE 530	Aqueous	5	100	212
Terpene Solvent	Solvent	5	100	212

Figure 6

C. Drying

When drying cleaned socket contacts, make certain that temperature limitations are not exceeded: -65° to 125°C [-85° to 257°F]. Excessive temperatures may cause degradation.

3.7. Checking Installed Socket Contact

All solder joints should conform to those specified in Workmanship Specification 101-21. The socket contact must seat on the pc board to within the tolerance shown in Figure 7. There shall be no deformation of the socket contact during the insertion operation that will affect the performance.

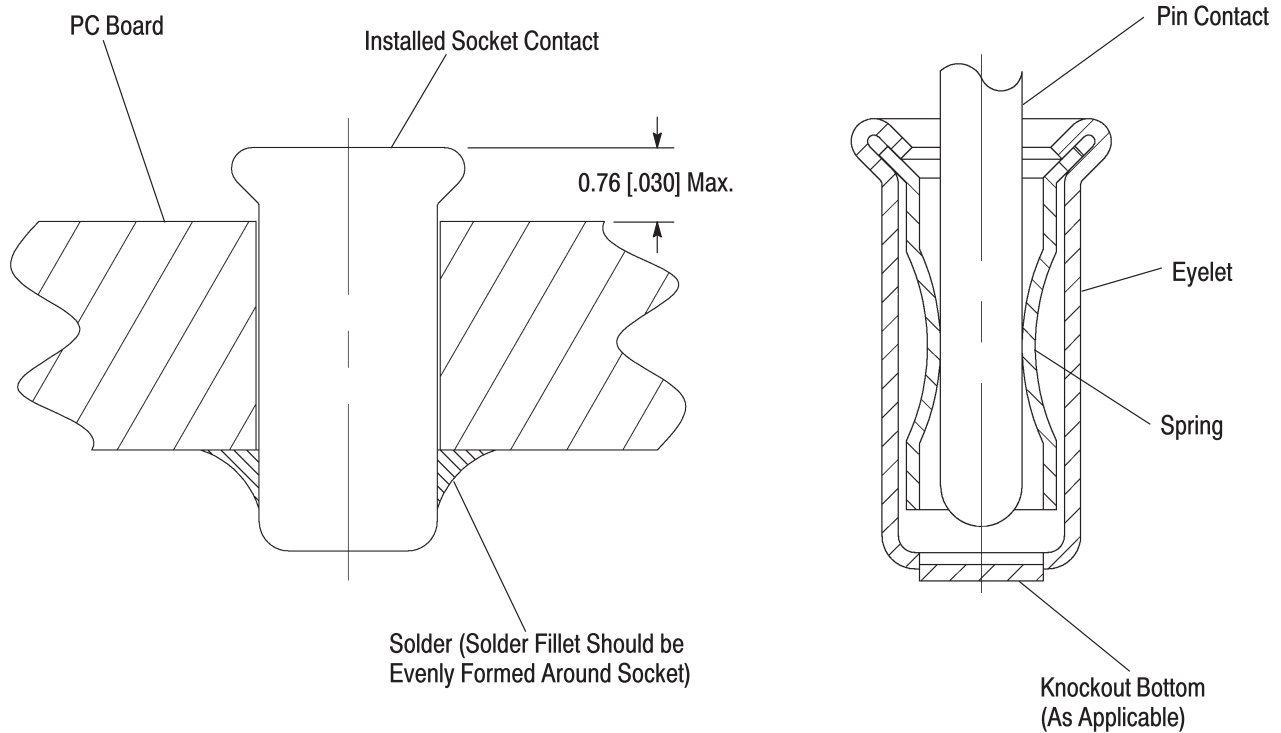

Figure 7

3.8. Repair/Replacement

Socket contacts are not repairable if damaged. Damaged socket contacts must be removed and replaced. The socket contact can be removed from the pc board by standard de-soldering methods.

4. QUALIFICATIONS

Miniature Spring Socket Contacts are not required to be agency approved.

5. TOOLING

Tyco Electronics has existing tooling for applying these socket contacts. Part numbers of available tooling and the applicable instructional material is provided in Figure 8. A customer supplied support fixture should be used in conjunction with the application of the Miniature Spring Socket Contacts.

MINIATURE SPRING SOCKETS		MINIATURE SPRING SOCKET TOOLING (DOCUMENT)	
SERIES SIZE	PIN DIAMETER ±0.025 [.001]	INSERTION MACHINE (409-5449)	HAND INSERTION TOOL (408-3280)
1	0.305 [.012]	682127-2	382378-1
2	0.355 [.014]	682127-3	
3	0.635 [.025]	682127-4	
4	0.889 [.035]	682127-5	
5	1.066 [.042]	682127-6	

Figure 8 (cont'd)



*Miniature Spring Socket
Insertion Tool
382378-1*

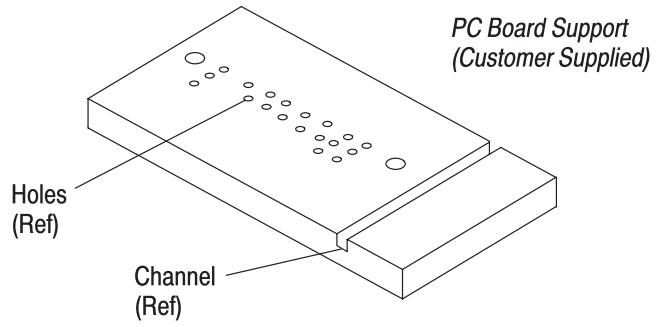

*Miniature Spring Socket Insertion Machine
(MSSIM & SCSIM) 682127-[]*

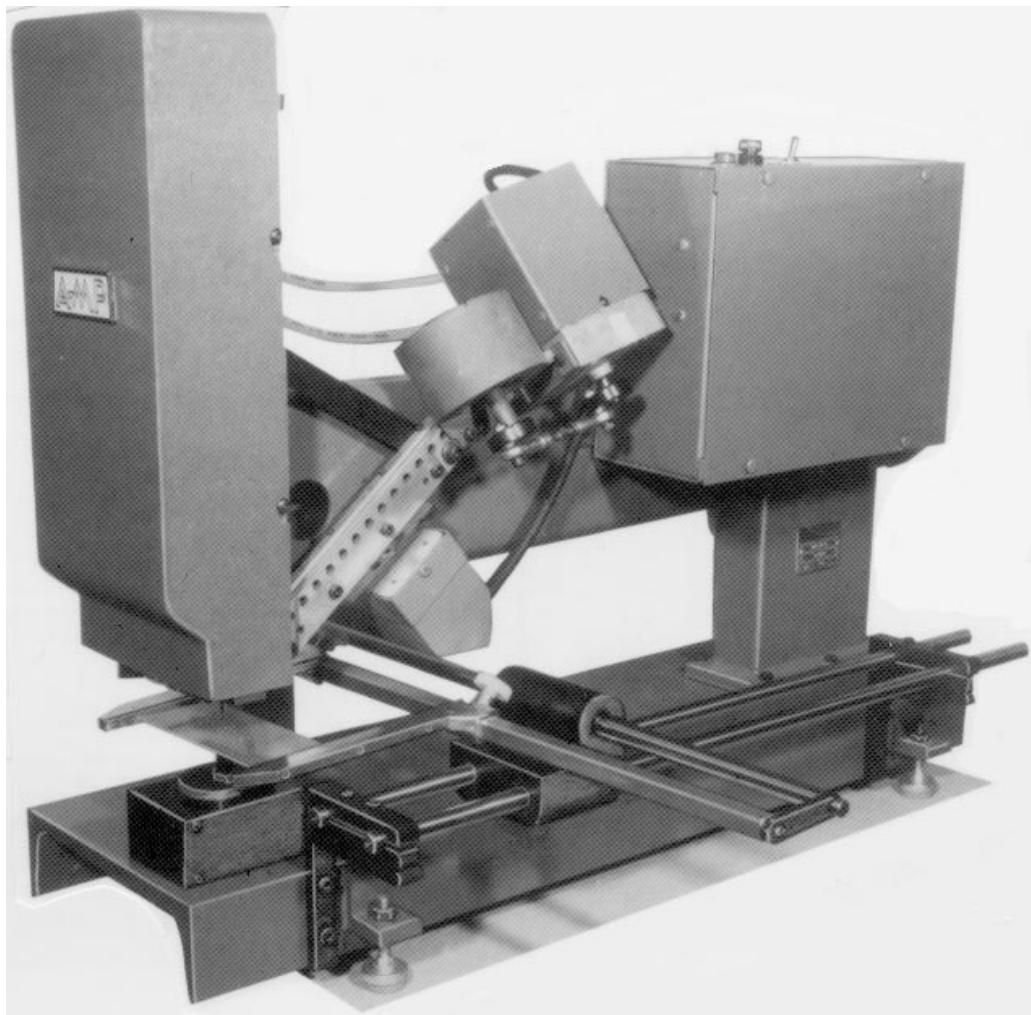

Figure 8 (end)

6. VISUAL AID

Figure 9 shows a typical application of a Miniature Spring Socket Contact. This illustration should be used by production personnel to ensure a correctly applied product. Applications which DO NOT appear correct should be inspected using the information in the preceding pages of this specification.

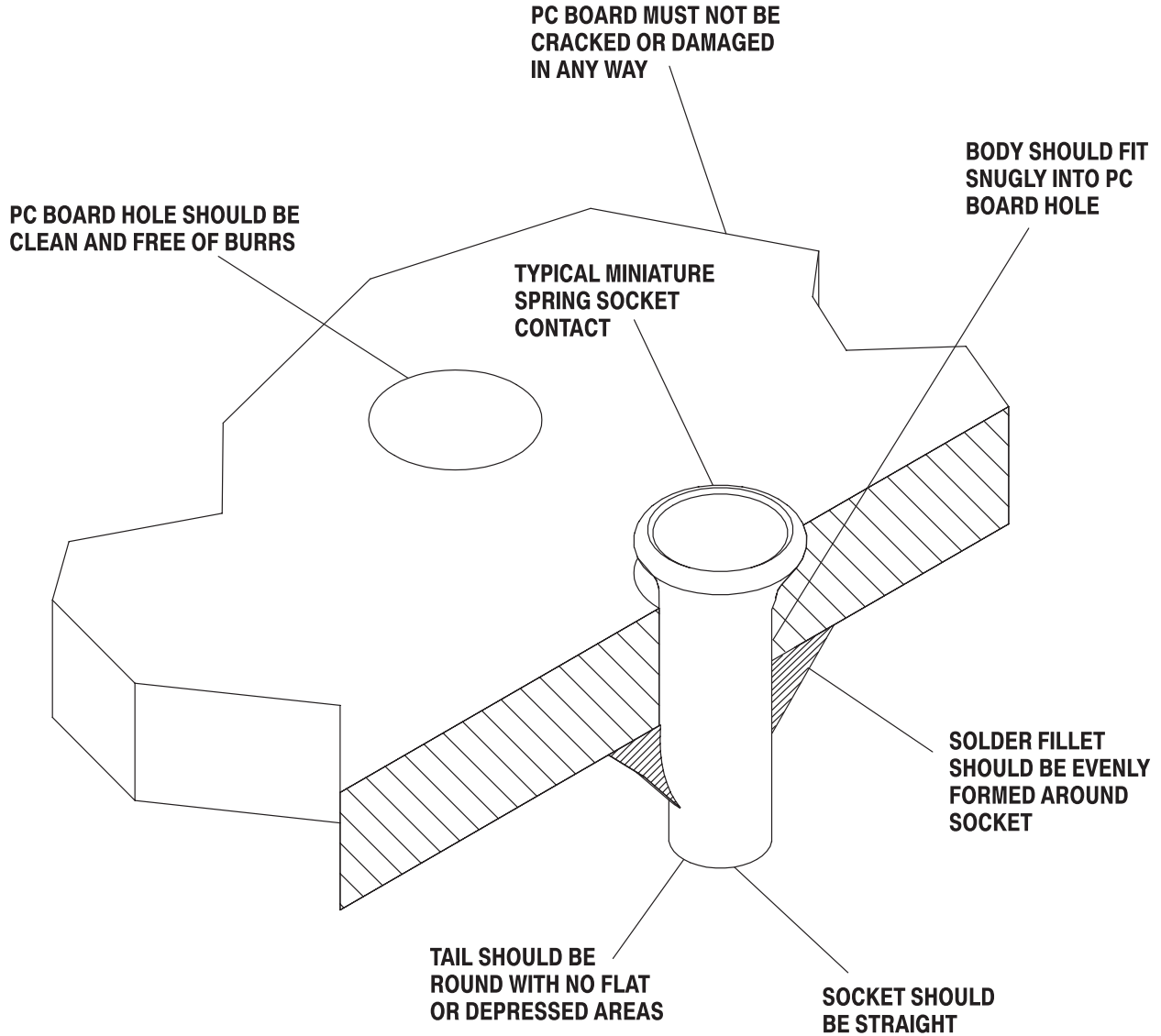

FIGURE 9. VISUAL AID