

NOTE



All numerical values are in metric units [with U.S. customary units in brackets]. Dimensions are in millimeters [and inches]. Unless otherwise specified, dimensions have a tolerance of ± 0.13 [$\pm .005$] and angles have a tolerance of $\pm 2^\circ$. Figures and illustrations are for identification only and are not drawn to scale.

1. INTRODUCTION

This specification covers requirements for the application of FASTON Flag Receptacles with Tab-Lok Feature. This special wire barrel crimp feature provides reliable electrical and mechanical performance. The characteristic feature of the crimp is a tab which is inserted through a slot in the terminal, then crimped between the bottom of the terminal and a pair of locking lances. Receptacles are available in a variety of mating configurations, and in three series sizes: 250, 205, and 187. The series designates the width of the mating tab. Also, most receptacles are made in two standard tab thicknesses: 0.51 and 0.81 mm [.020 and .032 in.]. Available types are shown in Figure 1.

When corresponding with Tyco Electronics Personnel, use the terminology provided in this specification to help facilitate your inquiry for information. Basic terms and features of components are provided in Figure 1.

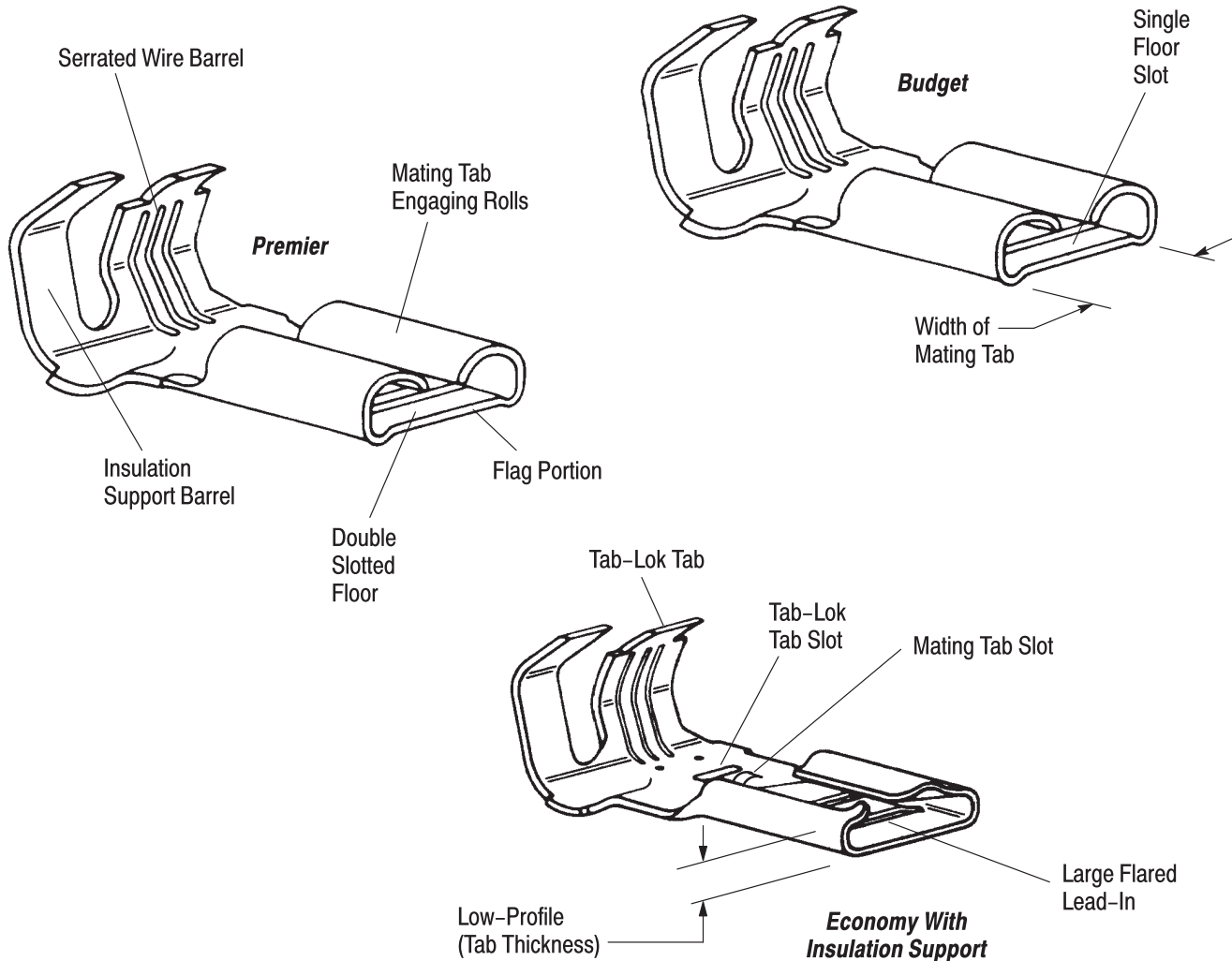

Figure 1 (cont'd)

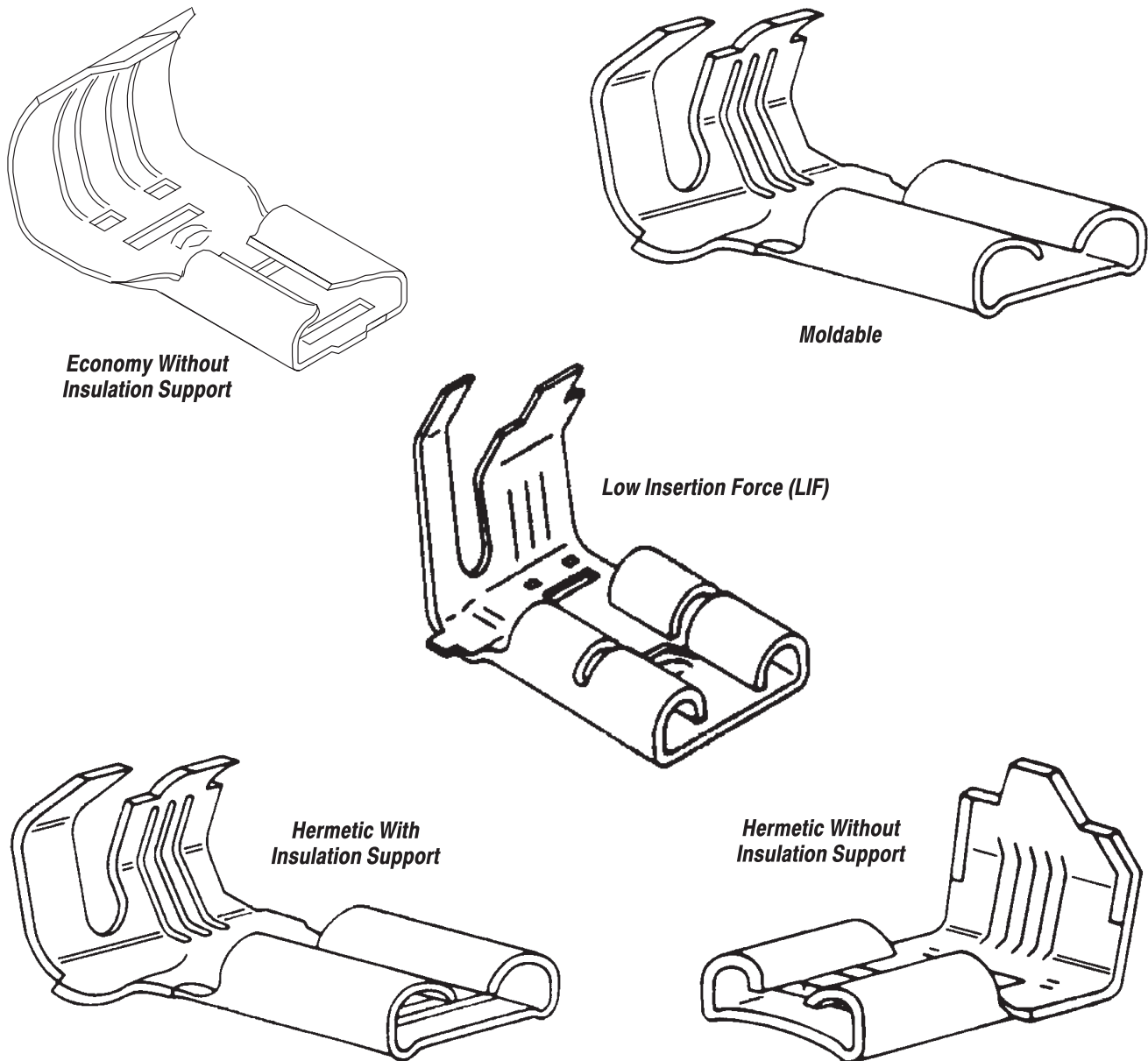

Figure 1 (end)

2. REFERENCE MATERIAL

2.1. Revision Summary

This paragraph is reserved for a revision summary of changes and additions made to this specification. The following changes were made for this revision.

- Updated document to corporate requirements
- New format

2.2. Customer Assistance

Reference Base Part Number 41531 and Product Code 1091 are representative numbers of FASTON Flag Receptacle with Tab-Lok Feature. Use of these numbers will identify the product line and expedite your inquiries through a service network established to help you obtain product and tooling information. Such information can be obtained through a local Tyco Electronics Representative or, after purchase, by calling the Tooling Assistance Center or Product Information number at the bottom of page 1.

2.3. Drawings

Customer Drawings for specific products are available from the service network. The information contained in Customer Drawings takes priority if there is a conflict with this specification or with any other technical documentation supplied by Tyco Electronics.

2.4. Specifications

These terminals are designed to perform to the test described by Underwriters Laboratories Inc. Specification UL 310.

2.5. Instructional Material

The following available Instruction Sheets (408-series) and Customer Manuals (409-series) are customer documents that provide application tooling information.

- 408-1601 Hand Crimping Tool 47417
- 408-8011 Standard Hinge Bar Applicators
- 408-8031 Miniature Quick-Change Applicators for Tab-Lok Terminals
- 409-5128 AMP-O-ELECTRIC* Model "K" Terminating Machine 1-471273-3
- 409-5842 AMP-O-ELECTRIC Model "G" Terminating Machines 354500-[]
- 409-5852 AMPOMATOR* CLS III-G Lead-Making Machine 122500-[]
- 409-5878 AMPOMATOR CLS IV+ Lead-Making Machine 356500-[]

3. REQUIREMENTS

3.1. Storage and Chemical Exposure Limitations

The chemicals listed below can cause stress corrosion cracking in brass receptacles.

- Alkalies
- Ammonia
- Citrates
- Phosphates
- Sulfur Compounds
- Amines
- Carbonates
- Nitrites
- Sulfides
- Tartrates



Where above environmental conditions exist, use phosphor-bronze receptacles instead of brass.

3.2. Product Selection

These receptacles have been designed to accommodate specific design requirements. The mating tab thickness and width for each are provided in Figure 2.

RECEPTACLE TYPE		MATING TAB THICKNESS AND WIDTH (SERIES)				
		250 SERIES 0.81 [.032] (Only Thickness Available)	205 SERIES		187 SERIES	
			0.81 [.032]	0.51 [.020]	0.81 [.032]	0.51 [.020]
Premier		X	X	X	X	
Budget		X		X	X	
Economy	w/Insulation Support	X	X	X	X	
	w/o Insulation Support	X				
Moldable		X			X	
Hermetic	w/Insulation Support	X				
	w/o Insulation Support	X				
LIF		X		X	X	

Figure 2

Terminals are divided into 6 types:

A. Premier

Resilient rolls and a double slotted floor allow maximum compliance toward mating tabs. Each receptacle is thermally stress-relieved to help resist the effects of overstressing, often caused by production situations. Premier receptacles also are further processed to clean and lubricate the surface prior to shipping.

B. Budget

Construction and characteristics are much the same as the Premier, but the Budget receptacles have only one floor slot, and do not receive special processing.

C. Economy

Distinguishable by a large, flared lead-in and relatively low profile of the mating end rolls.

D. Moldable

Available with no floor slots or openings, allowing over-mold processing.

E. Hermetic

Designed specifically to mate with posted header tabs in hermetic motor applications. Provides all the features and benefits of the Premier line.

F. LIF

A cantilevered floor design, a generous lead-in, and a two-stage roll (split-roll) feature provide reduced insertion forces for this line of receptacles. Minimum withdrawal forces are maintained by the design.

3.3. Wire Selection and Preparation

A. Selection

There are receptacle designs to accommodate a wire size range of 20 through 10 AWG and an insulation diameter range of 1.32 through 5.08 mm [.052 through .200 in.]. Selection is based on the application requirements (i.e., electric or signal carrying parameters).

B. Preparation

Strip the wire insulation according to the dimension provided in Figure 3.



The applied crimp dimension (within the functional range of the product) is dependent on the termination tooling being used. Refer to the documentation (applicator logs and instruction sheets) supplied with the termination tooling for the applied crimp height. See Section 5, TOOLING.



Do NOT nick, scrape, or cut the wire conductor during the stripping operation.

RECEPTACLE SERIES	STRIP LENGTHS (± 0.38 [$\pm .015$])	
	WITH INSULATION SUPPORT	WITHOUT INSULATION SUPPORT
250	5.59 [.220]	9.60 [.378]
205	5.59 [.220]	---
187	4.78 [.188]	---

Figure 3

3.4. Crimped Requirements

Locate the receptacle to be crimped in the appropriate tooling and perform the crimping operation according to the instructions packaged with that tooling. Check the appearance and crimping dimensions of the crimped terminal as follows.

A. Appearance

The center of the indent made by the tooling anvil should be in visual alignment with the center of the locking lances. Also the Tab-Lok tab should be compressed into the terminal. These and other special features of crimped terminals are shown in Figure 4.



Wire insulation shall NOT be cut or broken during the crimping operation. Reasonable care and handling by tooling operators should prevent this type of damage.

B. Crimp Dimensions

When checking crimp height, the measurement must be taken perpendicular to the flag portion of the receptacle with a micrometer. The anvil and spindle must be centered and in line with the tooling anvil indent as shown in Figure 4.

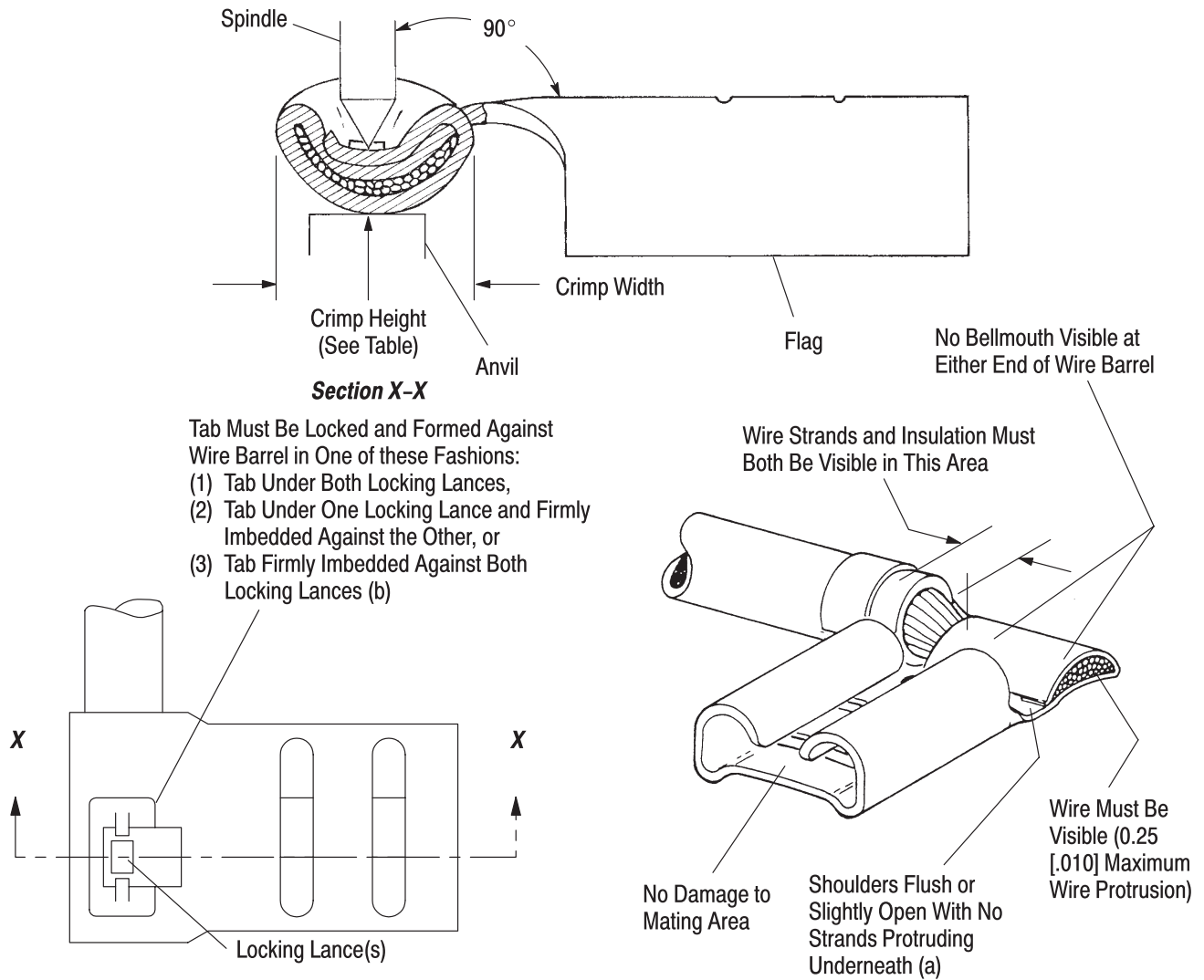

- NOTES:** (a) Hairline fracture allowable on floor at slot a *maximum* of half the distance from slot to terminal edge.
 (b) Fractures on locking lances are NOT permitted. The lances may, however, be slightly extruded or flattened without affecting crimp reliability.

Figure 4

3.5. Crimp Pull-Out Test

Crimped receptacles shall not separate from wires when subjected to forces specified in Figure 5.



Adjust tensile testing machine for head travel of 24.5 mm [1.00 in.] per minute. Directly and gradually apply force for 1 minute. (Hold the receptacle so that the force is applied straight-parallel to the crimp).

WIRE SIZE (AWG)	MINIMUM FORCE		WIRE SIZE (AWG)	MINIMUM FORCE	
	NEWTONS (N)	POUNDS (LBS)		NEWTONS (N)	POUNDS (LBS)
22	36	8	14	222	50
20	58	13	12	311	70
18	89	20	10	356	80
16	133	30	---	---	---

Figure 5

3.6. Mating Tab Dimensions

Features and dimensional requirements for tab terminals to be mated with FASTON Flag Receptacles are shown in Figure 6.

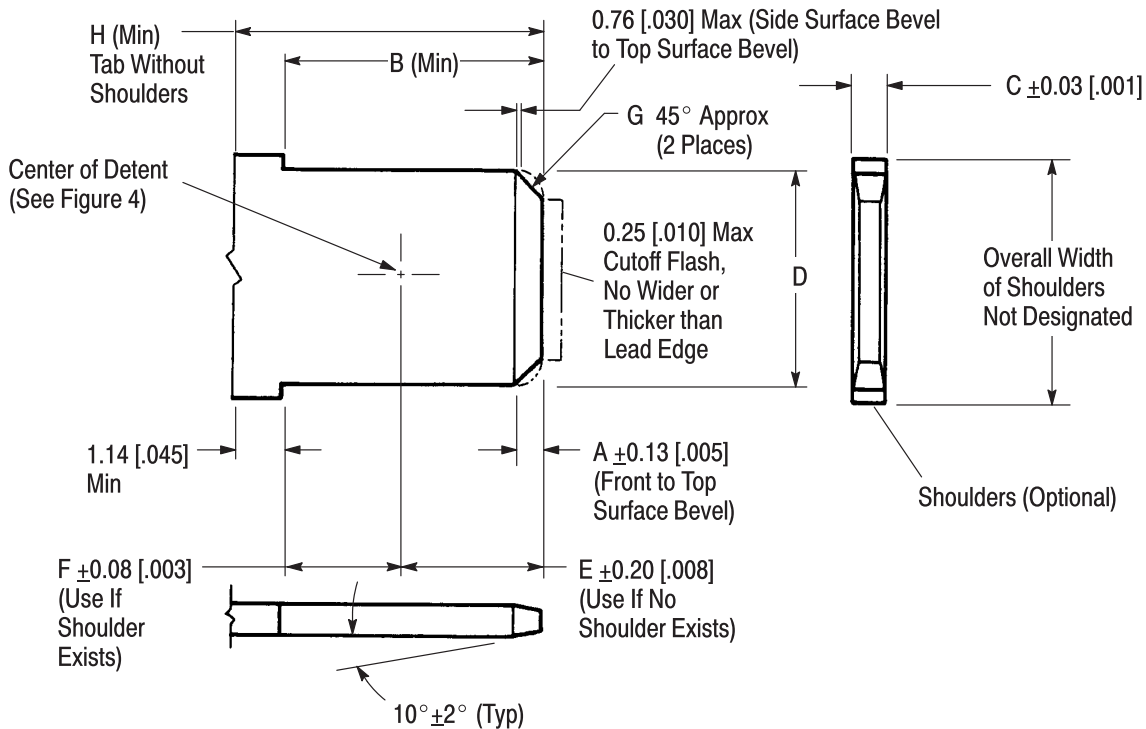

TAB SIZE (Nominal)	DIMENSION							
	A	B	C	D	E	F	G	H
6.35 x 0.81 [.250 x .032] w/Dimple	0.89 [.035]	7.80 [.307]	0.81 [.032]	6.35 [.250]	3.86 [.152]	4.06 [.160]	1.27 [.050]	8.94 [.352]
6.35 x 0.81 [.250 x .032] w/Hole	0.89 [.035]	7.80 [.307]	0.81 [.032]	6.35 [.250]	4.52 [.178]	3.40 [.134]	1.27 [.050]	8.94 [.352]
5.21 x 0.81 [.205 x .032] w/Dimple	0.89 [.035]	6.22 [.245]	0.81 [.032]	5.26 [.207]	2.54 [.100]	3.81 [.150]	1.27 [.050]	7.37 [.290]
5.21 x 0.81 [.205 x .032] w/Hole	0.89 [.035]	6.22 [.245]	0.81 [.032]	5.26 [.207]	3.17 [.125]	3.17 [.125]	1.27 [.050]	7.37 [.290]
5.21 x 0.51 [.205 x .020] w/Hole	0.89 [.035]	6.22 [.245]	0.51 [.020]	5.26 [.207]	3.17 [.125]	3.17 [.125]	1.14 [.045]	7.37 [.290]
4.75 x 0.81 [.187 x .032] w/Dimple	0.89 [.035]	6.22 [.245]	0.81 [.032]	4.75 [.187]	2.54 [.100]	3.81 [.150]	1.27 [.050]	7.37 [.290]
4.75 x 0.81 [.187 x .032] w/Hole	0.89 [.035]	6.22 [.245]	0.81 [.032]	4.75 [.187]	3.17 [.125]	3.17 [.125]	1.27 [.050]	7.37 [.290]
4.75 x 0.51 [.187 x .020] w/Dimple	0.76 [.030]	6.22 [.245]	0.51 [.020]	4.75 [.187]	2.54 [.100]	3.81 [.150]	1.14 [.045]	7.37 [.290]
4.75 x 0.51 [.187 x .020] w/Hole	0.76 [.030]	6.22 [.245]	0.51 [.020]	4.75 [.187]	3.17 [.125]	3.17 [.125]	1.14 [.045]	7.37 [.290]

NOTES: (1) Bevel may be a straight line or a radius within G ±0.51 mm [±.020 in.]. (2) Tab shall be flat (.001 inch/inch); and free from burrs greater than 10% of tab thickness, or raised plateaus, except as noted in Paragraph 3.8. (3) Measurements shall not include plating, burrs, or flatness tolerance.

Figure 6

3.7. Tab Retention and Detent Configurations

A tab configuration having no locking feature may be used for applications where low mating retention forces are desirable. Where higher forces are sought, a tab with a detent meeting specific requirements should be used. Hole detents provide the greatest retention forces, while dimples provide acceptable medium-range forces. Requirements are shown in Figure 7.

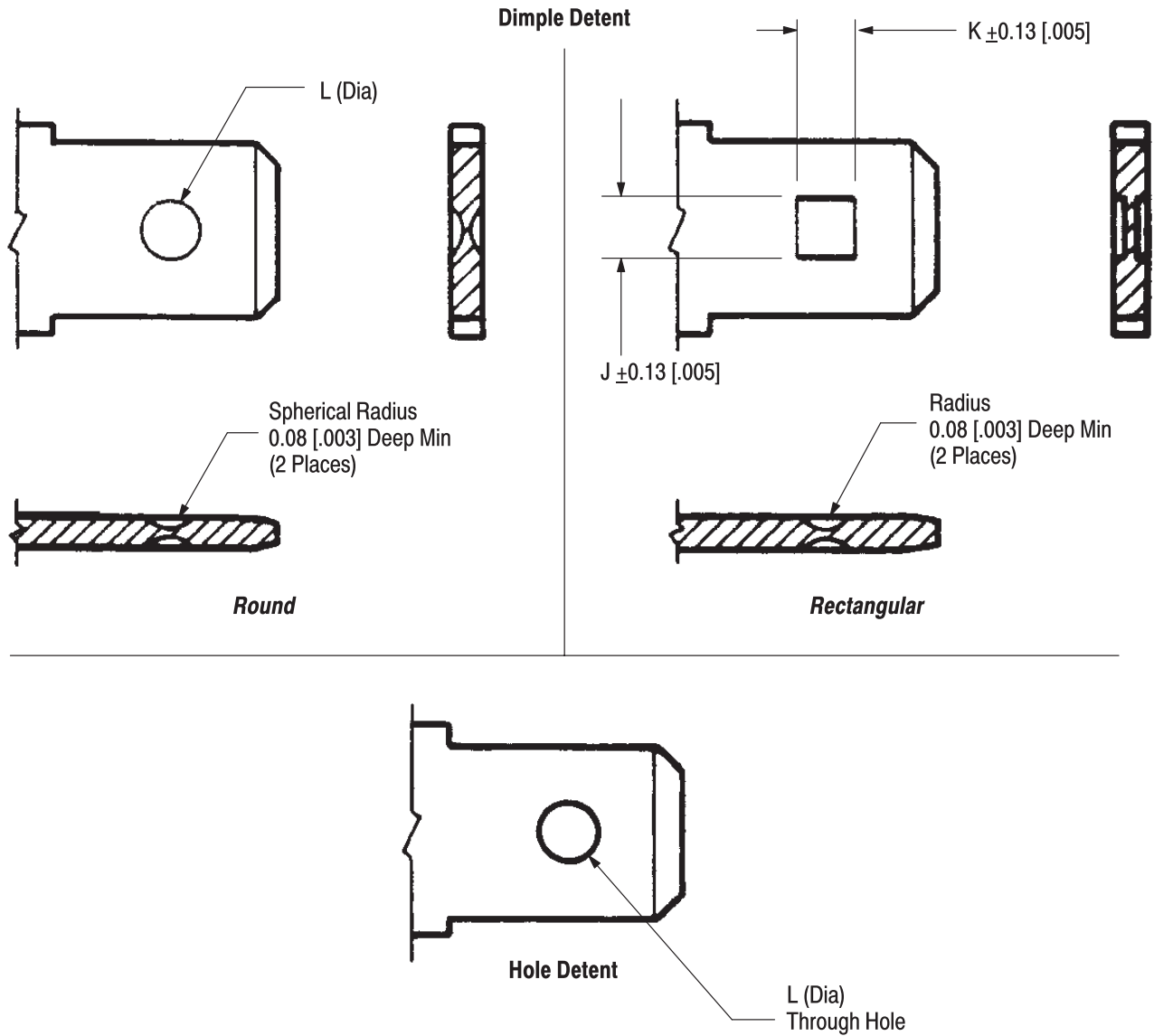

TAB WIDTH (Nominal)	DIMENSION		
	J (See Note 1)	K (See Note 1)	L
6.35 [.250]	2.36 [.093]	1.90 [.075]	$1.78 +0.25/-0.13$ [.070 +0.10/-0.005]
5.21 [.205]	2.36 [.093]	1.90 [.075]	1.78 ± 0.13 [.070 \pm .005]
4.75 [.187]	1.57 [.062]	1.37 [.054]	1.40 ± 0.13 [.055 \pm .005]

Figure 7

3.8. Mating Over-Cycle and Testing (Figure 8)

The forces required to mate and unmate test mating tabs and receptacles shall be as specified in the following table. Measure the force using a testing device capable of holding the reading. It must also provide accurate alignment with slow and steady mating and unmating of the test tab and receptacle.



Testing may be done using a gage as described in Residential Controls—Quick-Connect Terminals, ANSI/NEMA DC2—1982. Test tabs shall be dimensioned as shown in Figures 6 and 7 of this specification, except that the “C” dimension shall have a tolerance of 0.008 mm [.0003 in.] for brass tabs and 0.013 mm [.0005 in.] for steel; and raised plateaus around detents shall be limited to a total of 0.025 mm [.001 in.] for both sides. Test tabs meeting these requirement and assuring accurate test results can be purchased from Tyco Electronics.

TAB SIZE	FORCE (N [lb])				
	FIRST MATING (Maximum) INDIVIDUAL	FIRST UNMATING (Minimum)		SIXTH UNMATING (Minimum)	
		AVERAGE	INDIVIDUAL	AVERAGE	INDIVIDUAL
TEST TAB AND UNPLATED RECEPTACLE					
6.35 [.250]	80 [18]	27 [6]	18 [4]	22 [5]	18 [4]
5.21 [.205]	67 [15]	22 [5]	13 [3]	13 [3]	9 [2]
4.75 [.187]					
TEST TAB AND TIN-PLATED RECEPTACLE					
6.35 [.250]	76 [17]	22 [5]	13 [3]	18 [4]	13 [3]
5.21 [.205]	67 [15]	22 [5]	13 [3]	13 [3]	9 [2]
4.75 [.187]					

Figure 8

3.9. Repair

These receptacles are not repairable once termination has been made. Any defective receptacles should be removed and replaced with a new one.

4. QUALIFICATION

4.1. Underwriters Laboratories, Inc (UL)

Products meet UL-310 specification for quick-connect terminals and are Listed in UL Component Listing Program—Electrical File E-66717.



UL does not qualify this type of terminal for application to 24 AWG or smaller wire.

4.2. CSA International

CSA Certified in File LR7189.

4.3. National Electrical Manufacturers Association (NEMA)

These receptacles meet NEMA DC-2 mechanical requirements standard for quick-connect terminals.

5. TOOLING

Although hand crimping tooling is available for FASTON Flag Receptacles with the Tab-Lok feature, applicators and automatic machines are recommended for all applications. Applicators contain the tooling for feeding and crimping strip-form terminals. Automatic machines provide the power to operate the applicator. The receptacle size, type, wire load capacity, and the applicator and machines for applying the receptacles are provided in Figure 9.

Explanations for tooling and codes appearing in the table are:

Applicators = Standard Hinge Bar Applicator used in bench mounted AMP-O-ELECTRIC machine and Miniature Quick-Change Applicator used in AMPOMATOR machines.

K = AMP-O-ELECTRIC Model "K" Terminating Machine 1-471273-3

C = AMPOMATOR "CLS" Lead-Making Machines 122500-[], 356500-[]

G = AMP-O-ELECTRIC Model "G" Terminating Machines 354500-[]

Figure 9 provides information on specific tooling for crimping the FASTON Flag Receptacles with Tab-Lok Feature.

SIZE AND TAB THICKNESS	RECEPTACLE TYPE(S)	WIRE SIZE (INSUL DIA RANGE)	APPLICATOR TOOLING (DOCUMENT)		HAND TOOL
			"K" (409-5128)	"C" (409-5852) (409-5878) or "G" (409-5842)	
6.35 x 0.81 [.250 x .032]	Premier, Budget, Moldable, LIF, Economy w/Insulation Support, and Hermetic w/Insulation Support	22-12 (1.78-5.33 [.110-.210])	565504-1 (408-8011)	687395-1 (408-8031)	47417◆
	Right-Hand Economy w/o Insulation Support		565892-1 (408-8011)	686961-8 (408-8031)	
	Left-Hand Hermetic w/Insulation Support		566237-1 (408-8011)	---	
	Right-Hand/Left-Hand/Through-Splice Hermetic w/o Insulation Support and Right-Hand/Left-Hand/Through-Splice Economy w/o Insulation Support		566104-2● (408-8011)	---	
	Right-Hand Hermetic w/o Insulation Support		566092-1 (408-8011)	687638-5 (408-8031)	
	Left-Hand Hermetic w/o Insulation Support		566154-1 (408-8011)	687638-7 (408-8031)	
	FASTIN-FASTON* w/Insulation Support	16-14 (1.78-5.33 [.110-.210])	567303-2 (408-8011)	---	---
	Hermetic w/Insulation Support	12-10 (1.78-5.33 [.110-.210])	565505-2 (408-8011)	687389-1 (408-8031)	
	Right-Hand Hermetic w/o Insulation Support		566093-1 (408-8011)	687748-1 (408-8031)	
	Left-Hand Hermetic w/o Insulation Support		566276-1 (408-8011)	687748-3 (408-8031)	
Economy and Right-Hand/Left-Hand/Through-Splice Hermetic w/o Insulation Support	566071-3● (408-8011)		---		
5.21 x 0.51 [.205 x .020] 5.21 x 0.81 [.205 x .032]	Premier 0.30 [.012] Thick	20-16 (1.78-4.32 [.110-.170])	565501-1 (408-8011)	687392-1 (408-8031)	---
	Premier 0.41 [.016] Thick	20-14 (1.78-4.32 [.110-.170])	565501-1 (408-8011)	687391-1 (408-8031)	
4.75 x 0.51 [.187 x .020]	LIF	20-16 (1.78-4.32 [.110-.170])	565501-1 (408-8011)	687391-1 (408-8031)	
	Premier	20-16 (4.32-5.71 [.170-.225])	566281-1 (408-8011)	466799-1 (408-8031)	
4.75 x 0.51 [.187 x .020] 4.75 x 0.81 [.187 x .032]	Premier and Budget	20-16 (1.78-4.32 [.110-.170])	565501-1 (408-8011)	687392-1 (408-8031)	
	Moldable and Economy		565508-1 (408-8011)	687394-1 (408-8031)	

●May be powered by AMP-O-ELECTRIC Model "K" Terminating Machine 1-471273-2.

◆16 Gage only.

Figure 9 (cont'd)

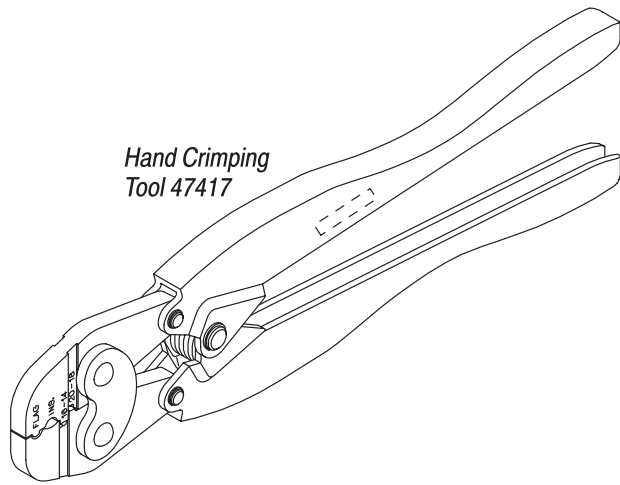

Hand Crimping
Tool 47417

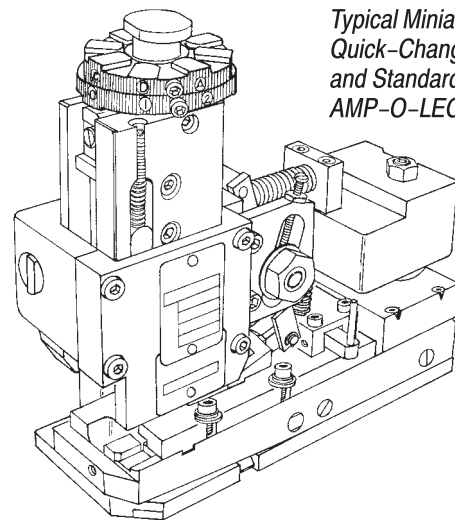

Typical Miniature
Quick-Change Applicator
and Standard Hinge Bar for
AMP-O-LECTRIC Machine

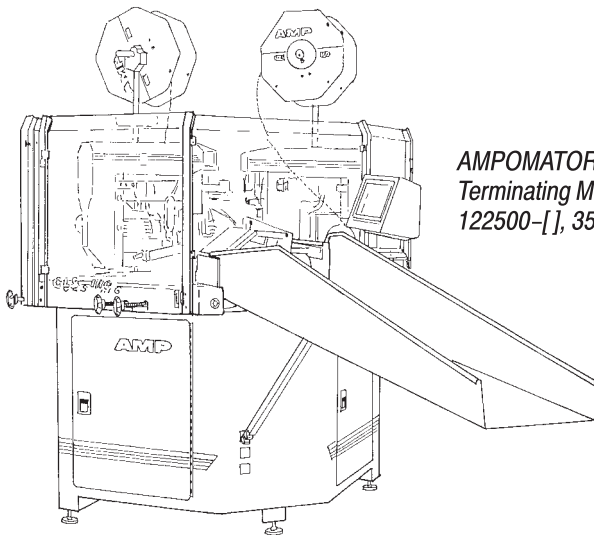

AMPOMATOR CLS
Terminating Machines
122500-[], 356500-[]

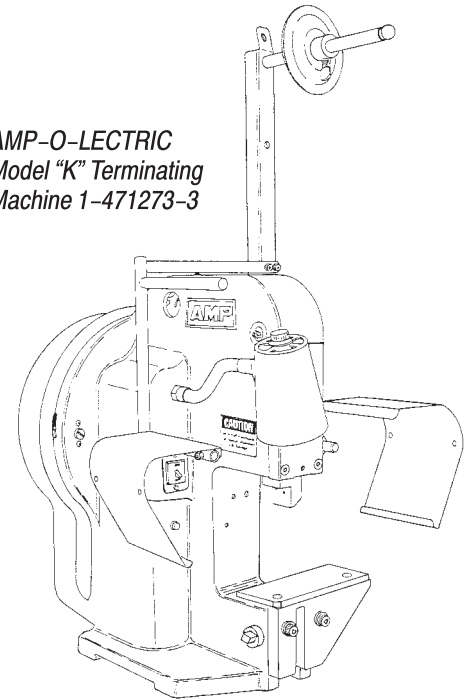

AMP-O-LECTRIC
Model "K" Terminating
Machine 1-471273-3

AMP-O-LECTRIC
Model "G" Terminating
Machine 354500-[]

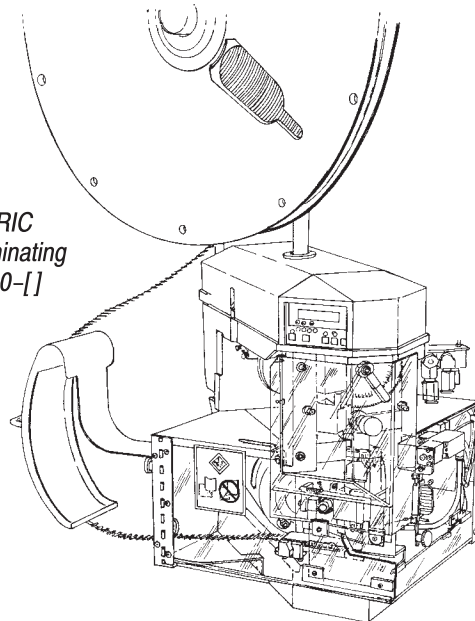

Figure 9 (end)

6. VISUAL AID

Figure 10 shows typical applications of FASTON Flag Receptacles with Tab-Lok Features. These illustrations should be used by production personnel to ensure a correctly applied product. Applications which DO NOT appear correct should be inspected using the information in the preceding pages of this specification and in the instructional material shipped with the product or tooling.

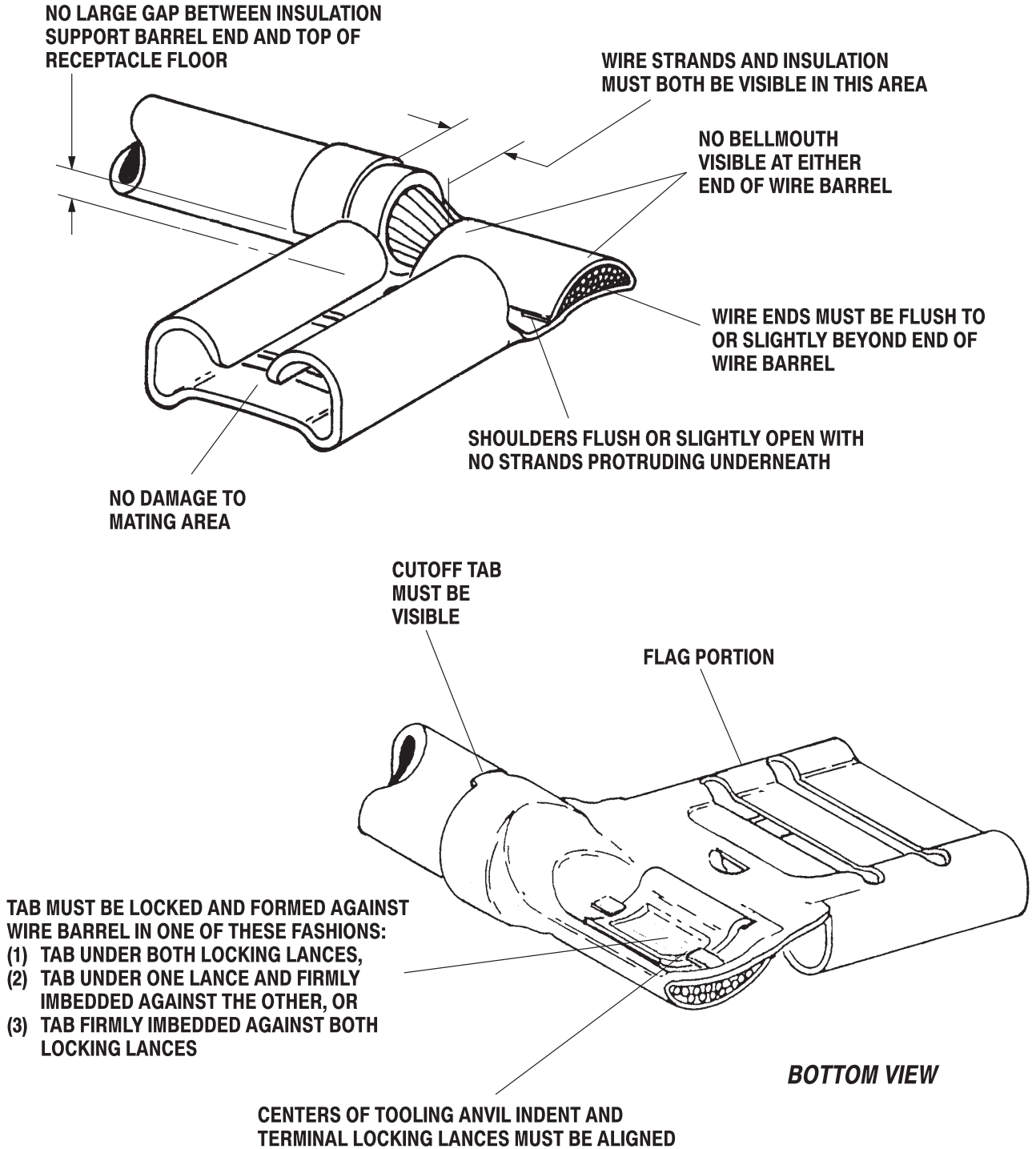

FIGURE 10. VISUAL AID