

**NOTE**



All numerical values are in metric units [with U.S. customary units in brackets]. Dimensions are in millimeters [and inches]. Unless otherwise specified, dimensions have a tolerance of  $\pm 0.13$  [ $\pm 0.005$ ] and angles have a tolerance of  $\pm 2^\circ$ . Figures and illustrations are for identification only and are not drawn to scale.

**1. INTRODUCTION**

This specification covers the requirements for application of the FFC (Flexible Flat Cable) Round Wire Pin and Receptacle Contacts. These requirements are applicable to hand or automatic machine crimping tools.

When corresponding with Tyco Electronics Personnel, use the terminology provided in this specification to help facilitate your inquiry for information. Basic terms and features of components are provided in Figure 1.

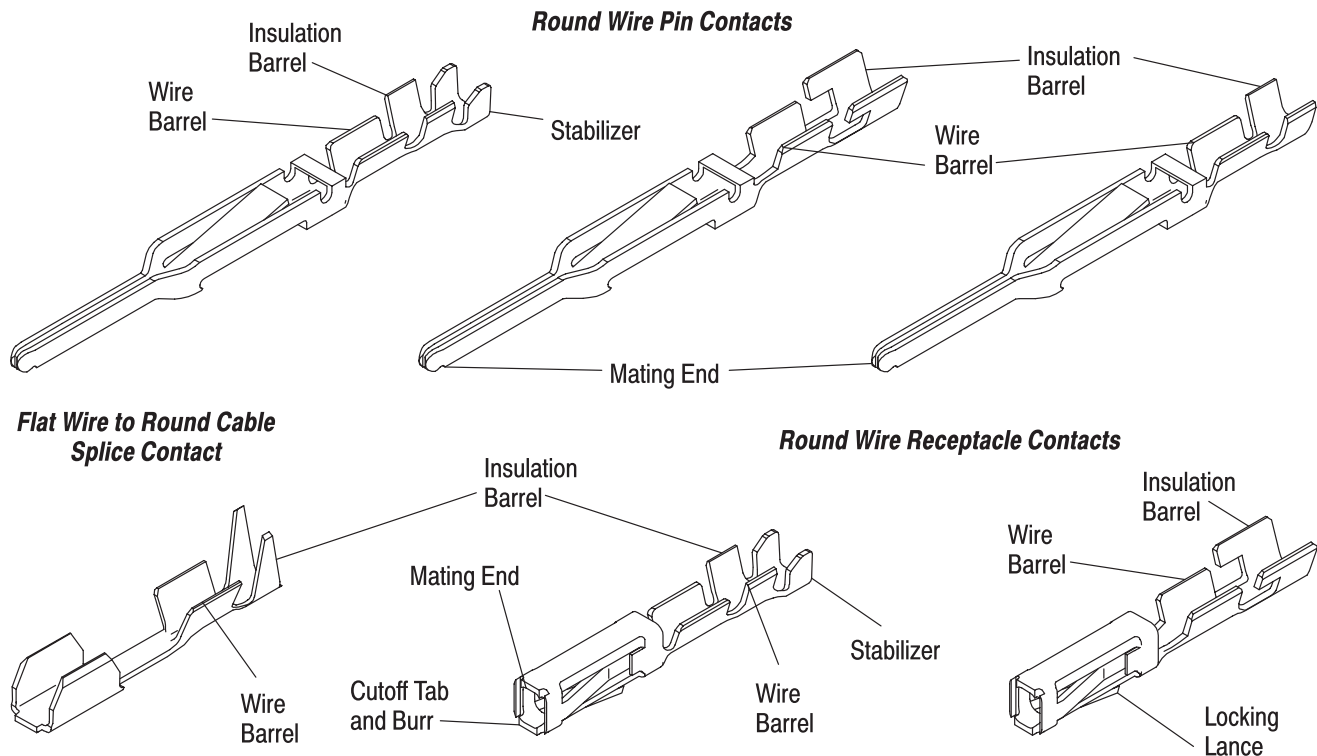

Figure 1

**2. REFERENCE MATERIAL**

**2.1. Revision Summary**

- Updated document to corporate requirements
- New format

**2.2. Customer Assistance**

Reference Part Number 88017 and Product Code 5176 are representative numbers of the FFC Round Wire Pin and Receptacle Contacts. Use of these numbers will identify the product line and expedite your inquiries through a service network established to help you obtain product and tooling information. Such information can be obtained through a local Tyco Electronics Representative or, after purchase, by calling the Product Information Center at the number at the bottom of this page.

**2.3. Drawings**

Customer Drawings for product part numbers are available from the service network. If there is a conflict between the information contained in the Customer Drawings and this specification or with any other technical documentation supplied, call the Product Information Center at the number at the bottom of this page.

## 2.4. Specifications

Product Specification 108-9024 provides product performance requirements and test results.

## 2.5. Instructional Material

The following list includes available instruction sheets (408-series) that provide assembly procedures for operation, maintenance and repair of tooling; and customer manuals (409-series) that provide setup, operation, and maintenance of machines.

<u>Document Number</u>	<u>Document Title</u>
408-3295	Preparing Reel of Contacts for Application Tooling
408-4021	PRO-CRIMPER* II Hand Tool Assembly 58535-1 with Die Assembly 58535-2
408-7424	Checking Terminal Crimp Height or Gaging Die Closure
408-7973	Hand Crimping Tool 90313-2
408-7974	Hand Crimping Tool 90222-6
408-8025	Miniature Quick-Change Applicator (Side-Feed Type)
408-8040	Heavy Duty Miniature Quick-Change Applicators (Side-Feed Type)
408-8053	Miniature (Mini) Quick-Change Applicators
408-8059	General Preventive Maintenance for Applicators
408-9640	Crimp Quality Monitor Applicators for Side-feed and End-Feed Applications
408-9816	Handling of Reeled Products
408-9930	PRO-CRIMPER II Frame Without Dies
409-5128	Basic AMP-O-LECTRIC* Model "K" Terminating Machine 565435-5
409-5842	AMP-O-LECTRIC Model "G" Terminating Machines 354500-[ ]
409-5852	AMPOMATOR* CLS III-G Lead Making Machine 122500-[ ]
409-5866	AMPOMATOR CLS IV Lead-Making Machine 217500-[ ]
409-5878	AMPOMATOR CLS IV+ Lead-making Machine 356500-[ ]
409-10012	AMP-O-MATIC* Side-Feed Stripper-Crimper III Machine No. 1320895-[ ]
409-10016	Entry Level Terminator (ELT) Machine 1338600-[ ]
409-10027	Stripping Module 1490502-[ ] and 1490500-[ ]
409-10029	Stripping Module 1490503-[ ] and 1490501-[ ]

## 3. REQUIREMENTS

### 3.1. Storage

#### A. Ultraviolet Light

Prolonged exposure to ultraviolet light may deteriorate the chemical composition used in the contact materials.

#### B. Reeled Contacts

When using reeled contacts, store coil wound reels horizontally and traverse wound reels vertically.

#### C. Shelf Life

The contacts should remain in the shipping containers until ready for use to prevent deformation to the contacts. The contacts should be used on a first in, first out basis to avoid storage contamination that could adversely affect signal transmissions.

#### D. Chemical Exposure

Do not store contacts near any chemicals listed below, as they may cause stress corrosion cracking in the contacts.

Alkalies	Ammonia	Citrates	Phosphates	Citrates	Sulfur Compounds
Amines	Carbonates	Nitrites	Sulfur	Nitrites	Tartrates

### 3.2. Materials

The pin and receptacle contacts are made of phosphor bronze. Both contacts are available in gold or bright-tin lead plating.

### 3.3. Wire Size and Preparation

The contacts will accept a wire size range of 32 to 22 AWG and may be terminated to either stranded or solid wire.



The applied crimp dimension (within the functional range of the product) is dependent on the termination tooling being used. Refer to the documentation (applicator logs and instruction sheets) supplied with the termination tooling for the applied crimp height. See Section 5, TOOLING.



DO NOT nick, scrape, or cut the wire conductor during the stripping operation.

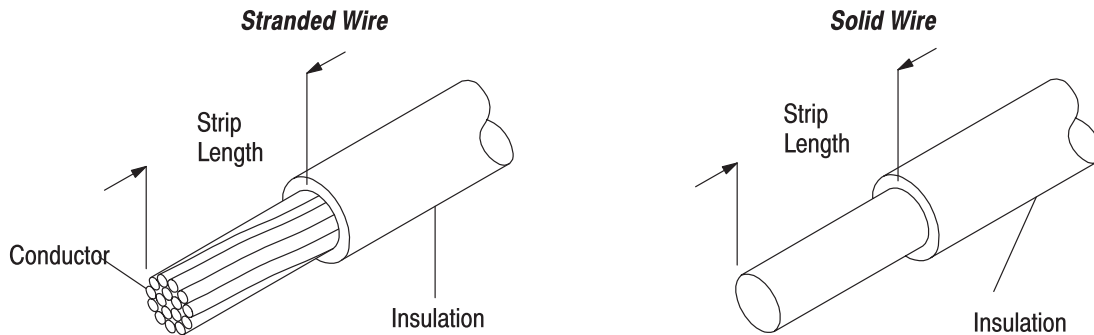

Note: Not to Scale

**AUTOMATIC MACHINE WIRE CRIMP DIMENSIONS**

WIRE SIZE RANGE	WIRE SIZE, AWG	INSULATION DIAMETER RANGE	STRIP LENGTH	WIRE BARREL CRIMP		INSULATION BARREL CRIMP	
				HEIGHT (RANGE)	WIDTH (NOM)	HEIGHT (MAX)	WIDTH (NOM)
32-26	32	0.64-1.22 [.025-.048]	3.56-2.79 [.140-.110]	0.61-0.56 [.024-.022]	1.07 [.042]	1.73 [.068]	1.57 [.062]
	30			0.64-0.56 [.025-.022]			
	28			0.64-0.56 [.025-.022]			
	26			1.63-0.64 [.028-.025]			
26-22	26	1.02-1.42 [.040-.056]	3.56-2.79 [.140-.110]	0.66-0.58 [.026-.023]	1.40 [.055]	1.73 [.068]	1.57 [.062]
	24			0.66-0.58 [.026-.023]			
	22			0.76-0.66 [.030-.026]			
24-22	24	1.02-1.42 [.040-.056]	3.56-2.79 [.140-.110]	0.69-0.58 [.027-.023]	1.40 [.055]	1.73 [.068]	1.78 [.070]
	22			0.76-0.66 [.030-.026]			

**HAND TOOL WIRE CRIMP DIMENSIONS**

WIRE SIZE RANGE	WIRE SIZE, AWG	INSULATION DIAMETER RANGE	STRIP LENGTH	WIRE BARREL CRIMP		INSULATION BARREL CRIMP	
				HEIGHT (RANGE)	WIDTH (NOM)	HEIGHT (MAX)	WIDTH (NOM)
32-26	32	0.64-1.22 [.025-.048]	3.56-2.79 [.140-.110]	0.61-0.56 [.024-.022]	1.07 [.042]	1.12 [.044]	1.57 [.062]
	30			0.61-0.56 [.024-.022]			
	28			0.61-0.56 [.024-.022]			
	26			0.71-0.64 [.028-.025]			
26-22	26	1.02-1.42 [.040-.056] or 0.89-1.52 [.035-.060]	3.56-2.79 [.140-.110]	0.69-0.58 [.027-.023]	1.40 [.055]	1.52 [.060]	1.57 [.062]
	24			0.69-0.58 [.027-.023]			
	22			0.76-0.66 [.030-.026]			
24-22	24	1.02-1.42 [.040-.056]	3.56-2.79 [.140-.110]	0.69-0.58 [.027-.023]	1.40 [.055]	1.52 [.060]	1.57 [.062]
	22			0.76-0.66 [.030-.026]			

Figure 2

### 3.4. Crimped Contact Requirements

The contact shall be located in desired tooling and crimped according to the instructions packaged with that tooling. See Section 5, TOOLING, of this document for details on tooling options and instructional materials.



*Wire insulation shall NOT be cut or broken during the crimping operation, nor shall the insulation be crimped into the contact wire barrel. Reasonable care should be taken by tooling operators to provide undamaged wire terminations.*

#### A. Wire Barrel Crimp

The crimp applied to the wire portion of the contact is the most compressed area and is most critical in ensuring optimum electrical and mechanical performance of the crimped contact. The contact wire barrel crimp height must be within the dimension provided in Figure 2.

#### B. Effective Crimp Length

For optimum crimp effectiveness, the crimp must be within the area shown and must meet the crimp dimensions provided in Figure 3. Effective crimp length shall be defined as that portion of the wire barrel, excluding bellmouth(s), fully formed by the crimping tool. Instructions for adjusting, repairing, and inspecting tools are packaged with the tools. See Section 5, TOOLING.

#### C. Bellmouths

Front and rear bellmouths shall be evident and conform to the dimensions given in Figure 3.

#### D. Cutoff Tabs

The cutoff tab shall be cut to the dimensions shown in Figure 3.

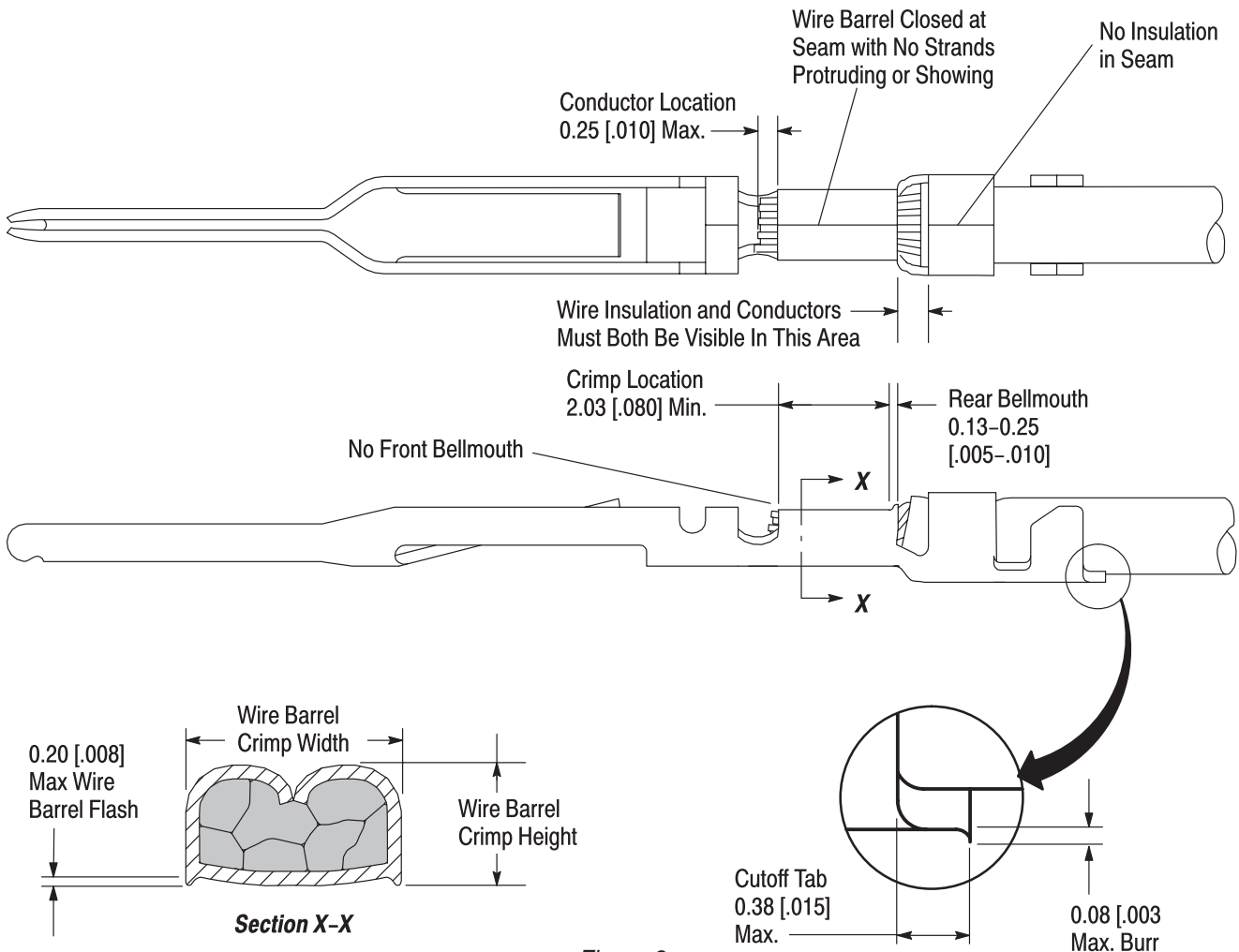

Figure 3

**E. Burrs**

The cutoff burr shall not exceed the dimensions shown in Figure 3.

**F. Wire Barrel Flash**

The wire barrel flash shall not exceed the dimensions shown in Figure 3, Section X-X.

**G. Insulation Barrel Crimp**

The insulation barrel shall grip the insulation firmly without cutting into it. Care must be taken to prevent cutting, nicking, or scraping of the insulation. Insulation crimp shall comply to width and height provided in Figure 3.

**H. Wire Location**

The wire conductor and insulation must be visible in the transition area between the wire and insulation barrels.

**I. Conductor Extension**

The conductor may extend beyond the wire barrel to the maximum shown.

**J. Wire Barrel Seam**

The wire barrel seam must be closed with no evidence of loose wire strands visible in the seam.

**K. Twist and Roll**

There shall be no twist, roll, deformation or other damage to the mating portion of the crimped contact that will impair usage of the contact. See Figure 4.

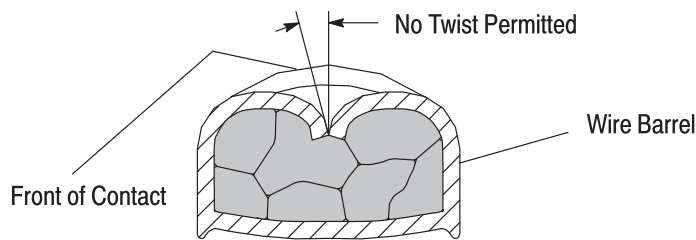

Figure 4

**L. Straightness**

The force applied during crimping may cause some bending between the crimped wire barrel and the mating portion of the contact. Such deformation is acceptable within the limits provided in Figure 5.

1. The side-to-side bend of the contact may not exceed the limits provided.
2. The up and down bend of the crimped contact, including cutoff tab and burr, shall not be bent above or below the datum line more than the amount shown.



Periodic inspections must be made to ensure crimped contact formation is consistent as shown.

**Side-to-Side Bend**

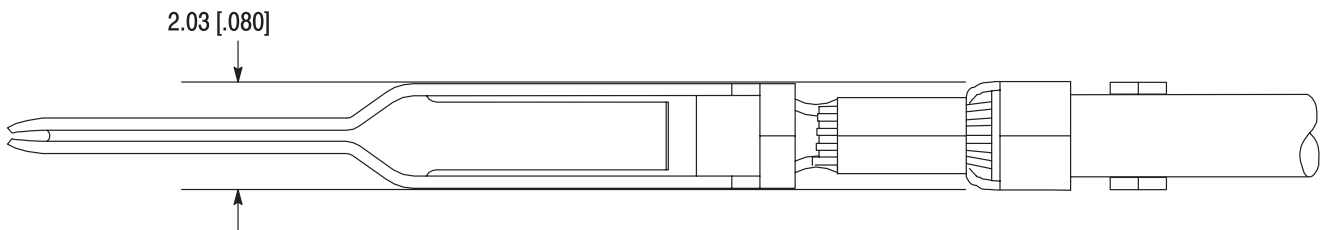

**NOTE:** Pin contact shown, socket contact has the same requirements.

Figure 5 (cont'd)

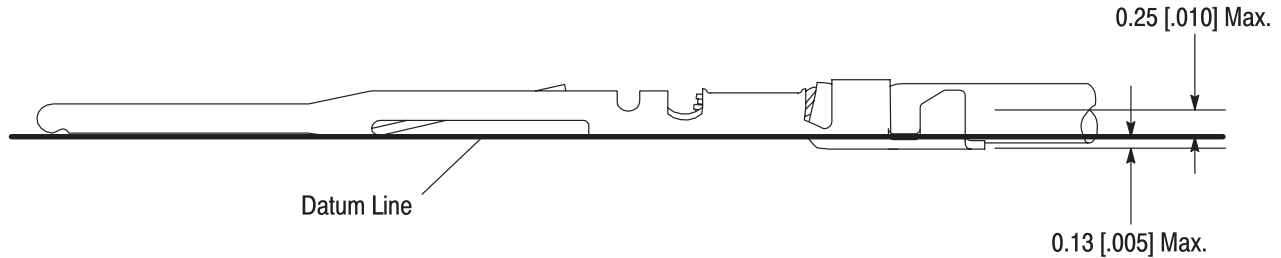
**Up and Down Bend**

**NOTE:** Pin contact shown, socket contact has the same requirements.

Figure 5 (end)

### 3.5. Contact Repair/Replacement

Once a contact has been damaged, it can not be used. It must be cut from the wire and replaced with a new contact.

## 4. QUALIFICATIONS

The FFC Round Wire Pin and Receptacle Contacts are not required to be agency approved.

## 5. TOOLING

This section provides a selection of tools for various application requirements. Modified designs and additional tooling concepts may be available to meet other application requirements. A list of tooling recommendations and instructional material packaged with the tooling covering the full wire size range is provided in Figure 6.

### NOTE



*Tool Engineers have designed machines for a variety of application requirements. For assistance in setting up prototype and production line equipment, contact Tool Engineering through your local Tyco Electronics Representative or call the Tooling Assistance Center number at the bottom of page 1.*

- **Applicators**

Applicators are designed for the full wire size range of strip-fed, precision formed contacts, and provide for high volume, heavy duty production requirements. The applicators can be used in bench or floor model power units.

### NOTE



*Each applicator is shipped with a metal identification tag attached. DO NOT remove this tag or disregard the information on it. Also, a packet of associated paperwork is included in each applicator shipment. This information should be read before using the applicator; then it should be stored in a clean, dry area near the applicator for future reference. Some changes may have to be made to the applicators to run in all related power units. Contact the Tooling Assistance Center number at the bottom of page 1 for specific changes.*

- **Power Units**

A power unit is an automatic or semi-automatic device used to assist in the application of a product. Power unit includes the power source used to supply the force or power to an applicator.

- **Hand Tools**

Hand crimping tools are designed for prototype, low-volume applications, and repair.

WIRE SIZE RANGE, AWG	INSULATION DIAMETER RANGE	APPLICATORS (DOCUMENT)	POWER UNIT (DOCUMENT)	HAND TOOL (DOCUMENT)
32-26	0.64-1.22 [.025-.048]	466242-1 (408-8040)	354500-1 (409-5842)	90313-2 (408-7973)
			565435-5 (409-5128)	
			1338600-3, -4 (409-10016)	
		466933-1 (N/A)	1320895-1, -3 (409-10012)	
26-22	1.02-1.42 [.040-.056]	466572-1 (408-8040)	122500-2, -3 (409-5852)	58535-1 (408-4021) or 90222-6 (408-7974) or 91537-1
			217500-1, -2 (409-5866)	
			356500-1, -2 (409-5878)	
		466572-2 (408-8040)	354500-1 (409-5842)	
			565435-5 (409-5128)	
			1338600-3, -4 (409-10016)	
		466572-3 (408-8040)	354500-[ ] (409-5842)	
			1338600-[ ] (409-10016)	
		466909-1 (N/A)	1320895-1, -3 (409-10012)	
	567651-2 (408-8040)	354500-1 (409-5842)		
	567884-1 (N/A)	1320895-1, -3 (409-10012)		
	0.89-1.52 [.035-.060]	567097-2 (408-8040)	354500-1 (409-5842)	
			565435-5 (409-5128)	
1338600-3, -4 (409-10016)				
24-22	1.02-1.42 [.040-.056]	567308-1 (408-8040)	122500-2, -3 (409-5852)	58535-1 (408-4021) or 90222-6 (408-7974)
			217500-1, -2 (409-5866)	
			356500-1, -2 (409-5878)	
		567308-2 (408-8040)	354500-1 (409-5842)	
			565435-5 (409-5128)	
			1338600-3, -4 (409-10016)	
		567308-3 (408-8040)	354500-[ ] (409-5842)	
			1338600-[ ] (409-10016)	
		687620-2 (408-8025)	354500-[ ] (409-5842)	
			1338600-[ ] (409-10016)	

Figure 6 (cont'd)



Typical Single Action Hand Tool with Certi-Crimp

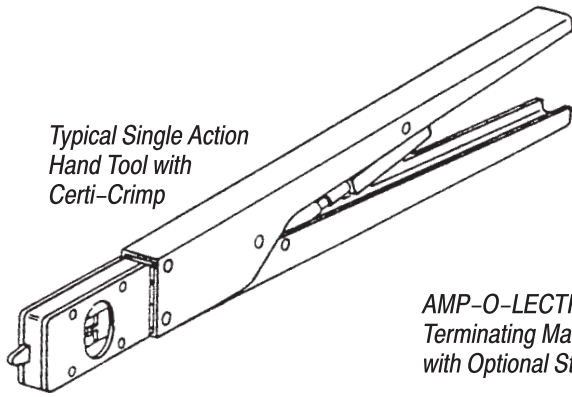

Typical PRO-CRIMPER Hand Tool with Dies

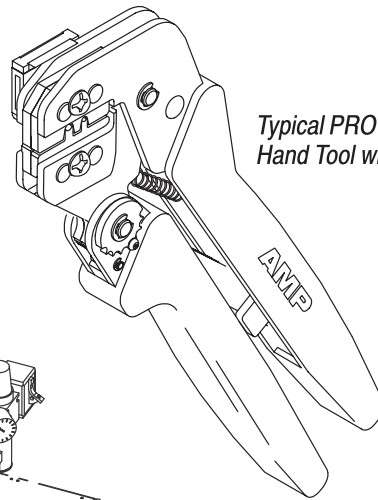

AMP-O-LECTRIC Model "G" Terminating Machine 354500-[] with Optional Stripping Module

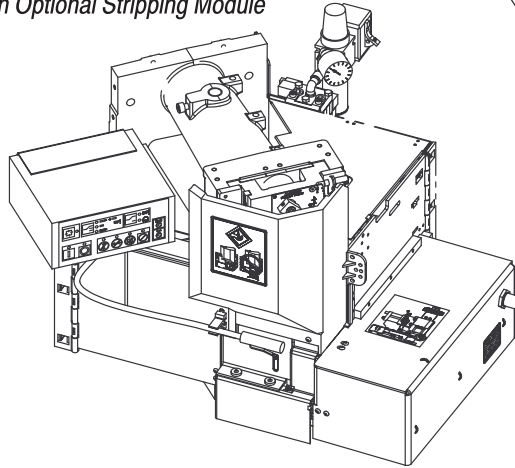

AMP-O-MATIC Side Feed Stripper-Crimper II Machine 1320895-[]

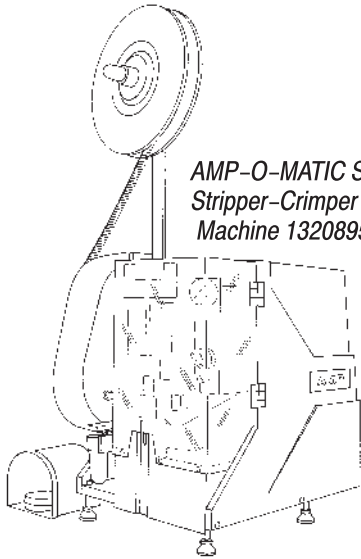

Typical Miniature Quick-Change Applicator

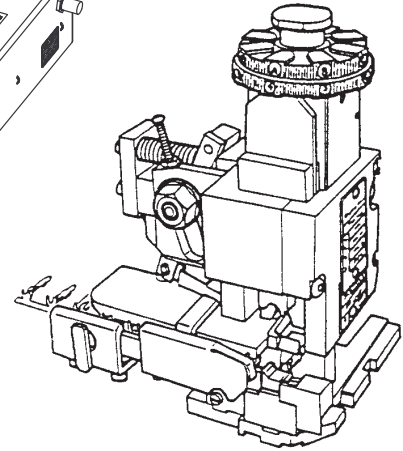

ELT Machine 1338600-[] with Optional Stripping Module

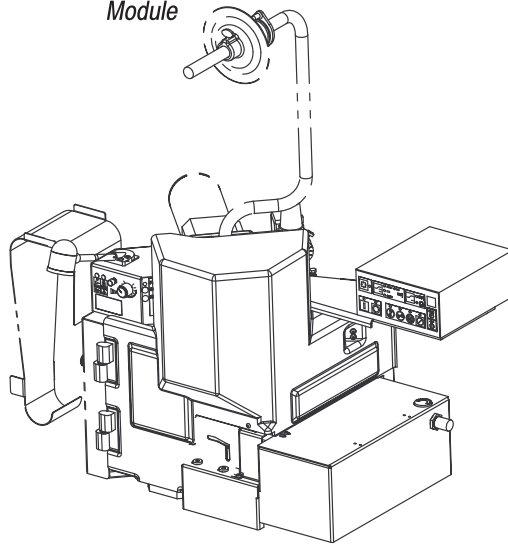

AMPOMATOR CLS Lead-Making Machines 122500-[]; 217500-[]; 356500-[]

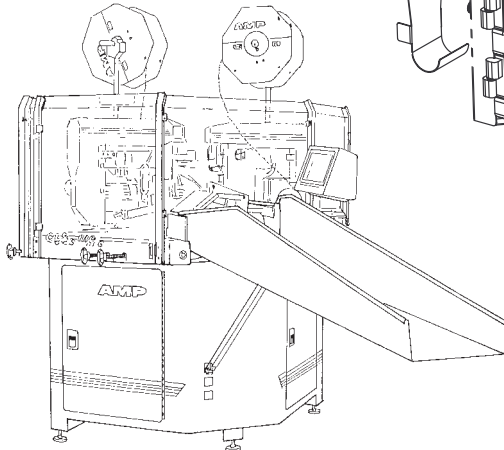

AMP-O-LECTRIC Model "K" Terminating Machine 565435-5

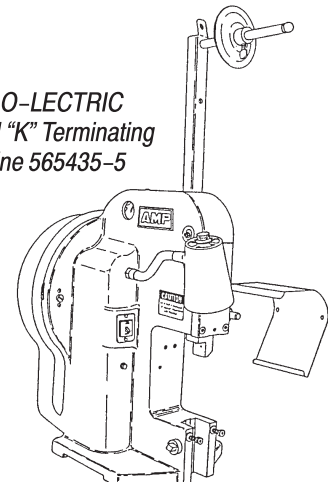
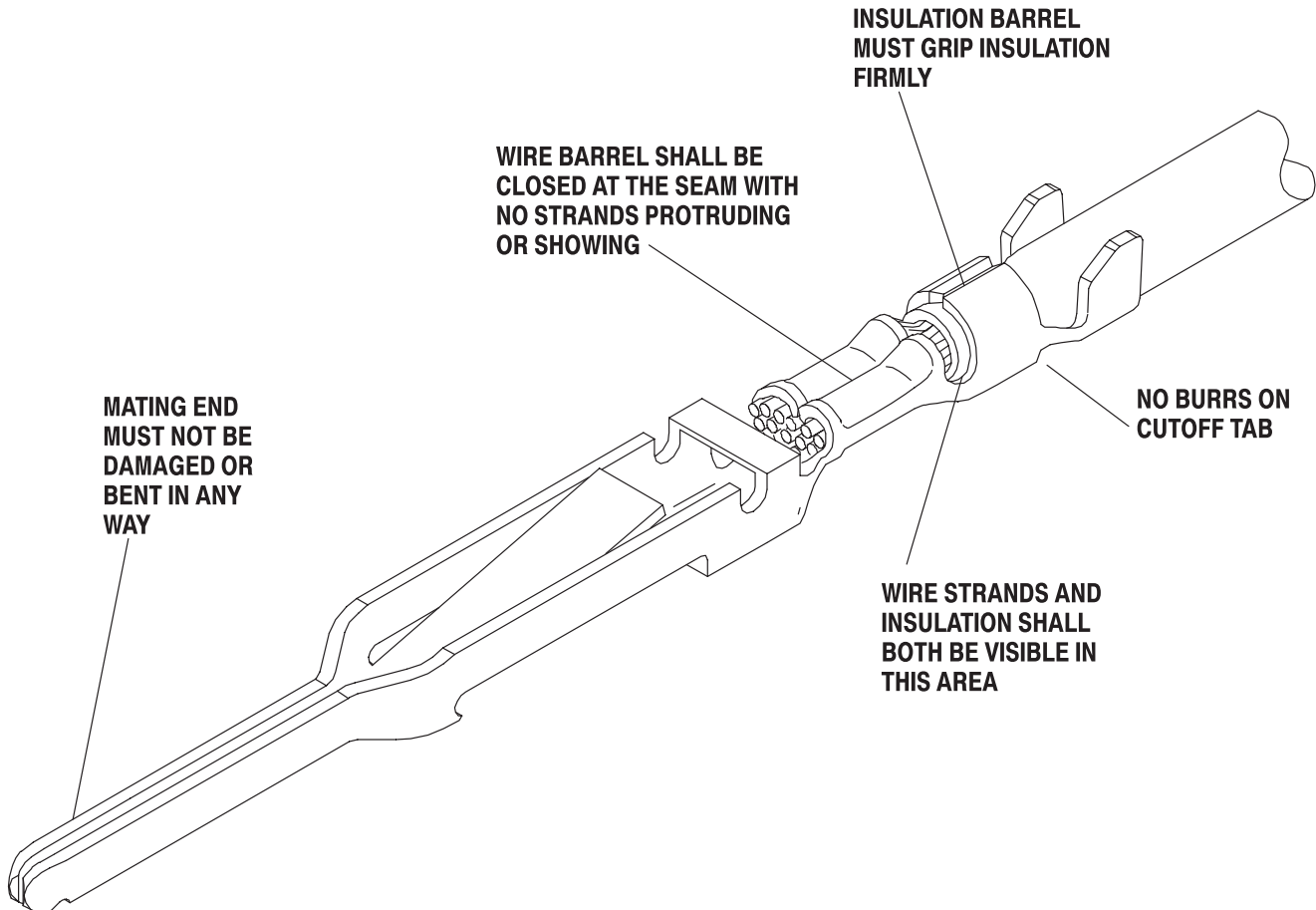

Figure 6 (end)



## 6. VISUAL AID

Figure 7 shows a typical application of FFC Round Wire Pin and Receptacle Contacts. This illustration should be used by production personnel to ensure a correctly applied product. Applications which DO NOT appear correct should be inspected using the information in the preceding pages of this specification and in the instructional material shipped with the product or tooling.



**FIGURE 7. VISUAL AID**