

THIS DRAWING IS UNPUBLISHED. RELEASED FOR PUBLICATION
 © COPYRIGHT BY TYCO ELECTRONICS CORPORATION. ALL RIGHTS RESERVED.

LOC	DIST	REVISIONS			
P	LTR	DESCRIPTION	DATE	DWN	APVD
DW	—	RELEASED	12JAN06	OH	WK

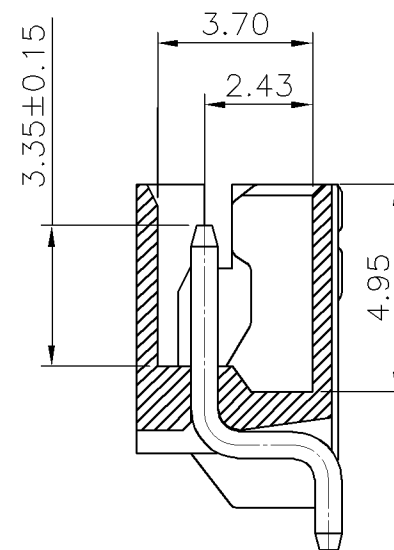
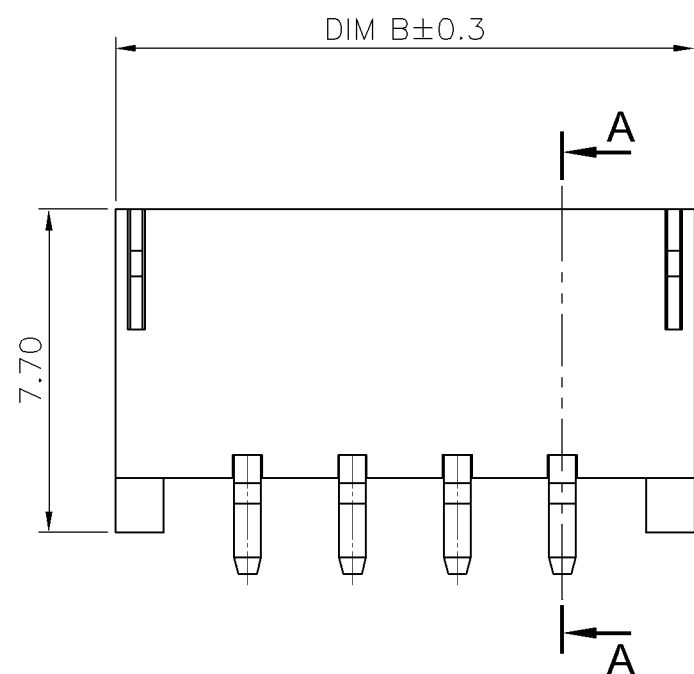
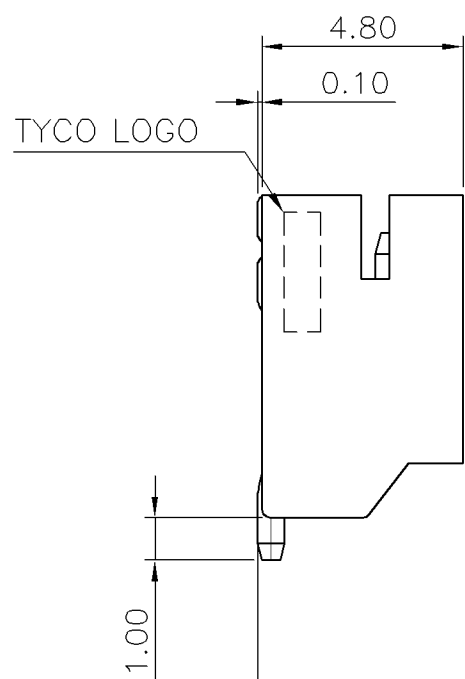
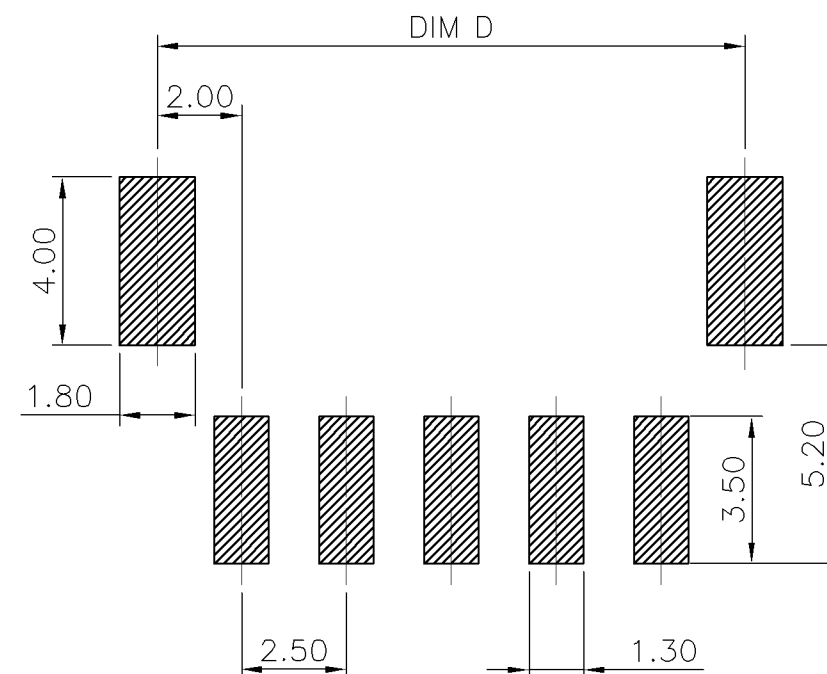
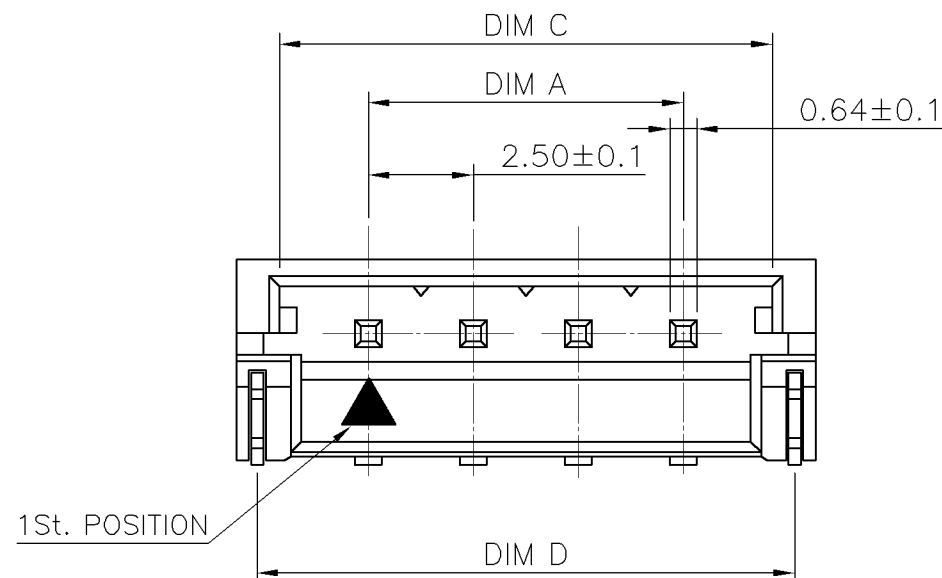

RECOMMENDED PCB LAYOUT

DIM D	DIM C	DIM B	DIM A	POS.	PART NUMBER
40.3	39.2	41.3	35.00	15	1-1775316-5
37.8	36.7	38.8	32.50	14	1-1775316-4
35.3	34.2	36.3	30.00	13	1-1775316-3
32.8	31.7	33.8	27.50	12	1-1775316-2
30.3	29.2	31.3	25.00	11	1-1775316-1
27.8	26.7	28.8	22.50	10	1-1775316-0
25.3	24.2	26.3	20.00	9	1775316-9
22.8	21.7	23.8	17.50	8	1775316-8
20.3	19.2	21.3	15.00	7	1775316-7
17.8	16.7	18.8	12.50	6	1775316-6
15.3	14.2	16.3	10.00	5	1775316-5
12.8	11.7	13.8	7.50	4	1775316-4
10.3	9.2	11.3	5.00	3	1775316-3
7.8	6.7	8.8	2.50	2	1775316-2

- NOTE:
- MATERIAL:
HOUSING: PA9T, VIRGIN, UL 94V-0, COLOR: NATURAL.
CONTACTS: BRASS.
 - FINISH:
CONTACTS: 2.0µm [80µ"] MIN. MATTE-TIN OVER 1.27µm [50µ"] MIN.
NICKEL ON ENTIRE CONTACT.
 - REFLOW SOLDER CAPABLE TO 260°C PER TYCO TEST SPEC.
109-201, CONDITION B.

0.10
ALL SOLDER TAILS AND PEGS

THIS DRAWING IS A CONTROLLED DOCUMENT.		DWN O. HU 10JAN2006	Tyco Holdings (Bermuda) VII Ltd. Taiwan Branch		
DIMENSIONS: MM		CHK S. HOU 10JAN2006			
TOLERANCES UNLESS OTHERWISE SPECIFIED:		APVD W.J. KE 10JAN2006	NAME		
0 PLC ± - 1 PLC ± 0.25 2 PLC ± 0.15 3 PLC ± 0.05 4 PLC ± - ANGLES ± 3°		PRODUCT SPEC 108-57099	HPI CONN., 2.5MM PITCH R/A, SMT TYPE		
MATERIAL SEE NOTE		QUALIFICATION TEST REPORT 501-57057	SIZE A3	CAGE CODE 00779	DRAWING NO C-1775316
FINISH SEE NOTE		WEIGHT --	RESTRICTED TO --		SCALE --
CUSTOMER DRAWING			SHEET 1 OF 2	REV A	

THIS DRAWING IS UNPUBLISHED. RELEASED FOR PUBLICATION
 © COPYRIGHT BY TYCO ELECTRONICS CORPORATION. ALL RIGHTS RESERVED.

LOC	DIST	REVISIONS					
DW	—	P	LTR	DESCRIPTION	DATE	DWN	APVD
				SEE SHEET 1.			

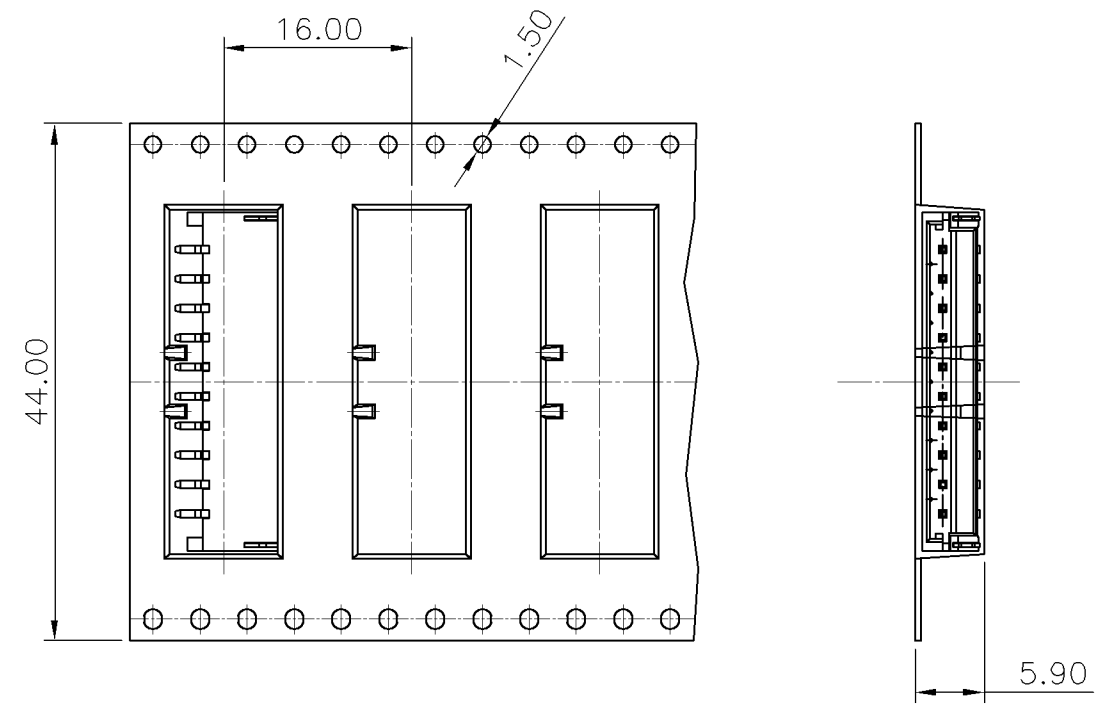
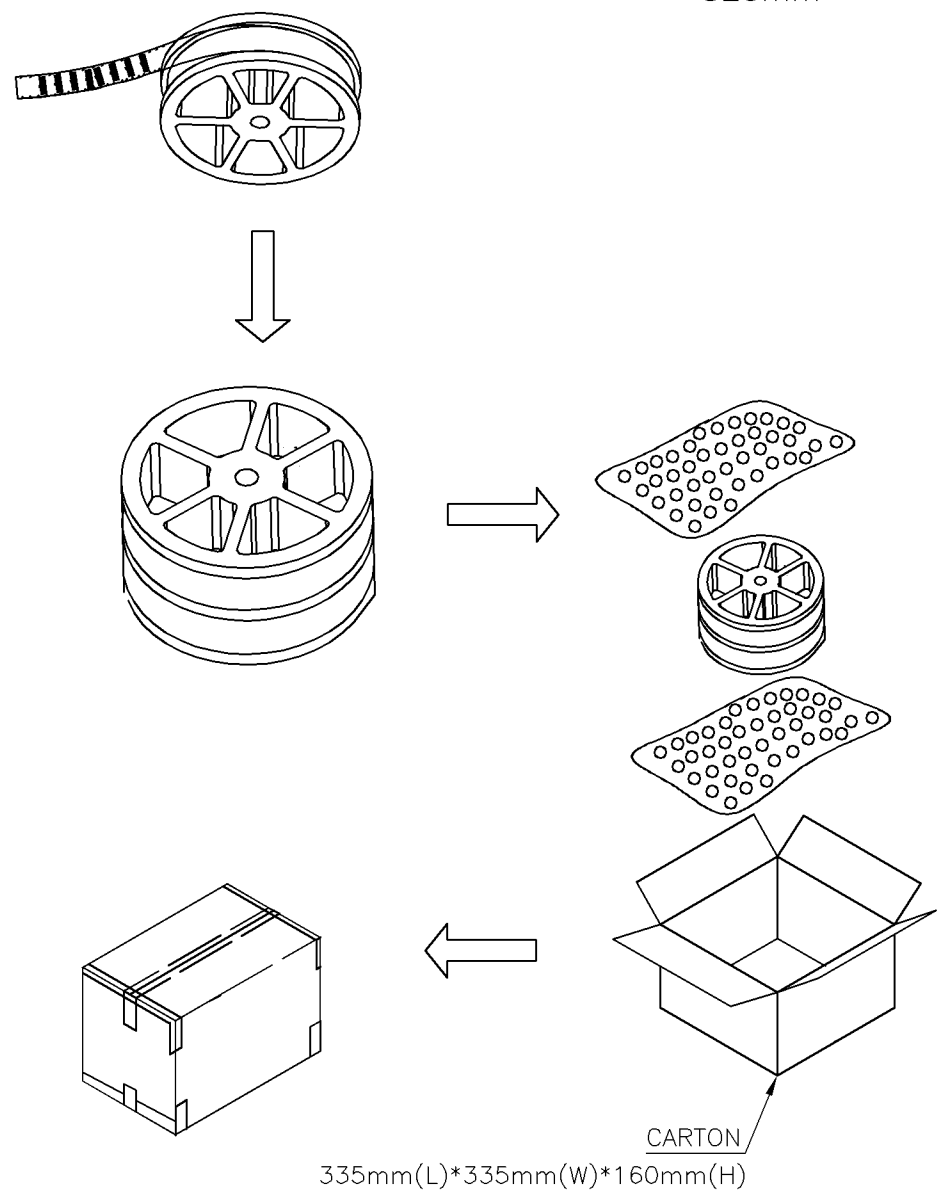
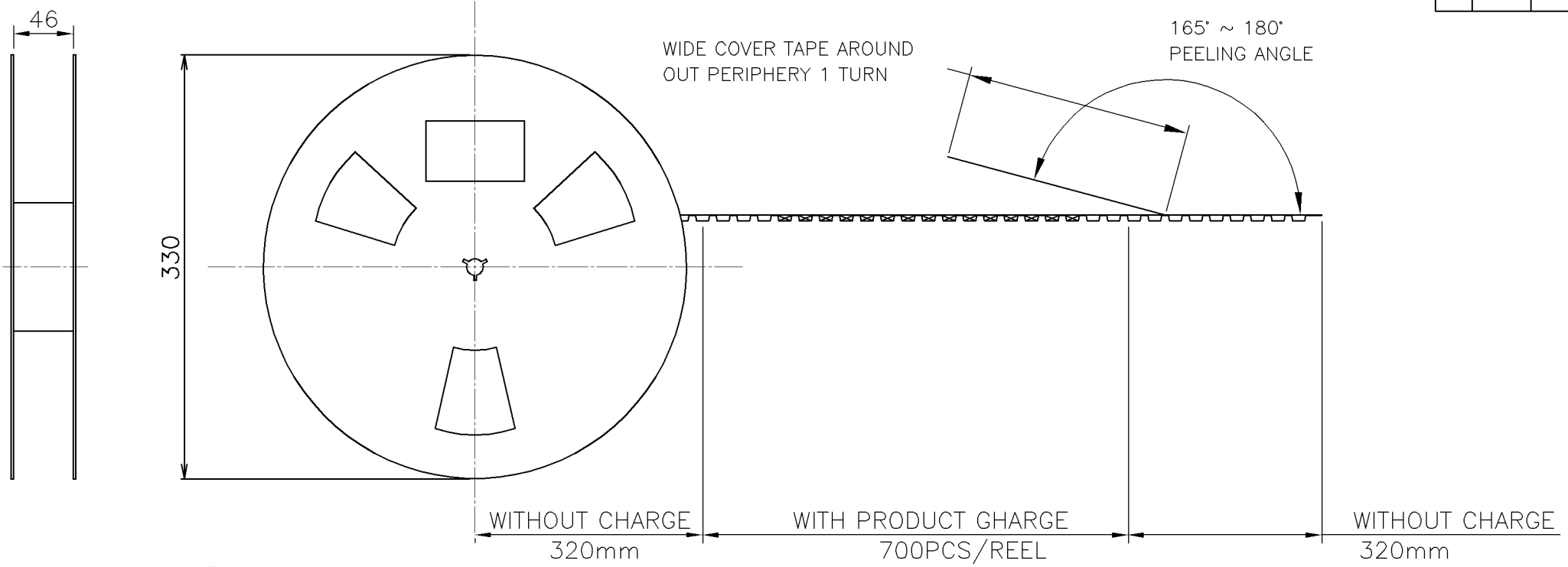

2,100	700	15	1-1775316-5
2,100	700	14	1-1775316-4
2,100	700	13	1-1775316-3
2,100	700	12	1-1775316-2
2,100	700	11	1-1775316-1
2,800	700	10	1-1775316-0
2,800	700	9	1775316-9
2,800	700	8	1775316-8
2,800	700	7	1775316-7
3,500	700	6	1775316-6
3,500	700	5	1775316-5
3,500	700	4	1775316-4
3,500	700	3	1775316-3
3,500	700	2	1775316-2
PCS/CARTON	PCS/REEL	POS.	PART NUMBER

THIS DRAWING IS A CONTROLLED DOCUMENT.

DWN	O. HU	10JAN2006	 Tyco Holdings (Bermuda) VII Ltd. Taiwan Branch
CHK	S. HOU	10JAN2006	
APVD	W.J. KE	10JAN2006	
PRODUCT SPEC	NAME		
APPLICATION SPEC			HPI CONN., 2.5MM PITCH R/A, SMT TYPE
WEIGHT			RESTRICTED TO
CUSTOMER DRAWING			SCALE — SHEET 2 OF 2 REV A

DIMENSIONS: MM	TOLERANCES UNLESS OTHERWISE SPECIFIED:	SIZE	CAGE CODE	DRAWING NO	RESTRICTED TO
0 PLC ± -	1 PLC ± -	A3		C-1775316	—
2 PLC ± -	3 PLC ± -				
4 PLC ± -	ANGLES ± -				
MATERIAL	FINISH				
—	—				