

4

3

2

1

THIS DRAWING IS UNPUBLISHED. RELEASED FOR PUBLICATION

© COPYRIGHT BY TYCO ELECTRONICS CORPORATION. ALL INTERNATIONAL RIGHTS RESERVED.

LOC

DIST

REVISIONS

HB

—

P

LTR

DESCRIPTION

DATE

DWN

APVD

E1

CHANGE PART STATUS

03-AUG-09

D.L

BH.Y

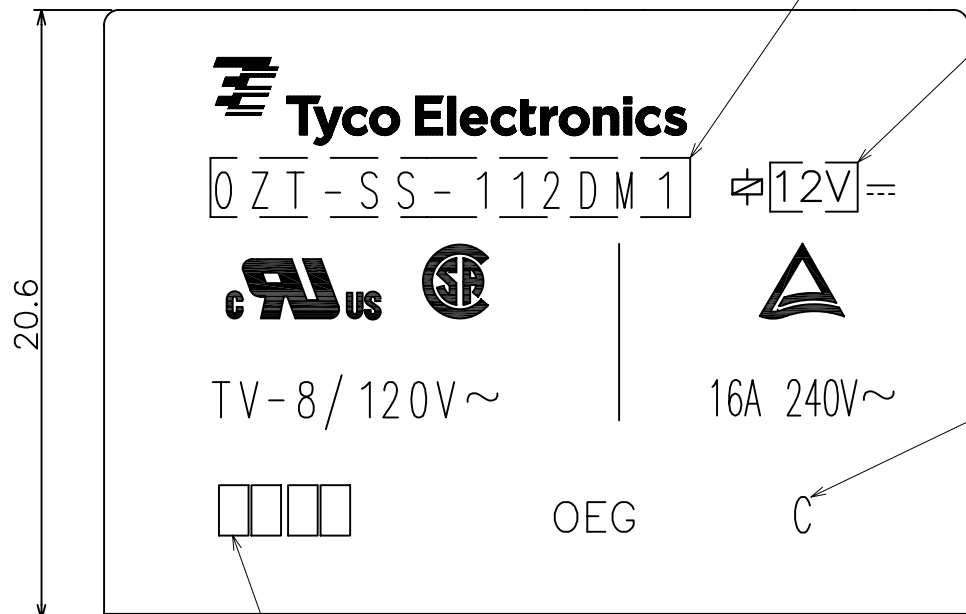
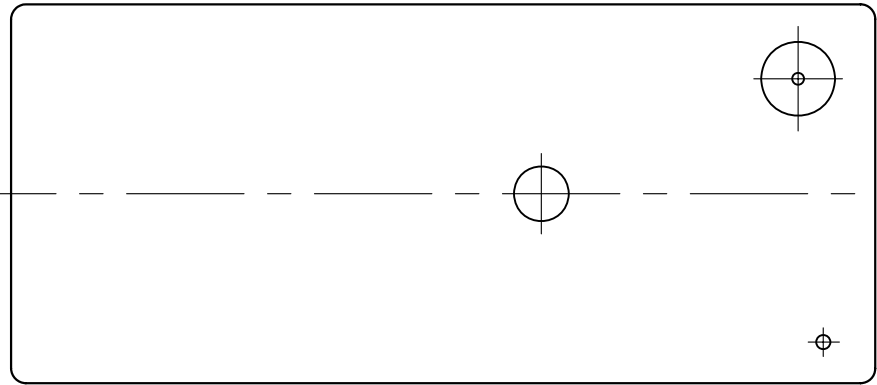

PART A

PART B

LOT NO.

C:MADE IN CHINA

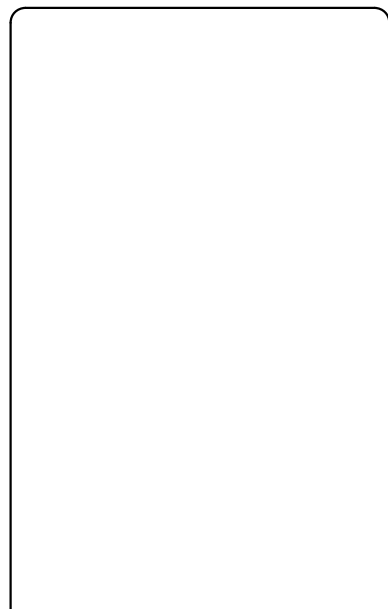

NOTES:

1. TERMINAL DIMENSION IS NOT INCLUDING SOLDER TIP.

2. LOT NO. SYSTEM AS FOLLOWING:

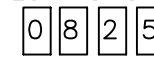

WEEK YEAR

3. GENERAL TOLERANCE AS FOLLOW:

TOLERANCE	
0~0.99mm	±0.1
1mm~2.99mm	±0.2
3mm MIN.	±0.3

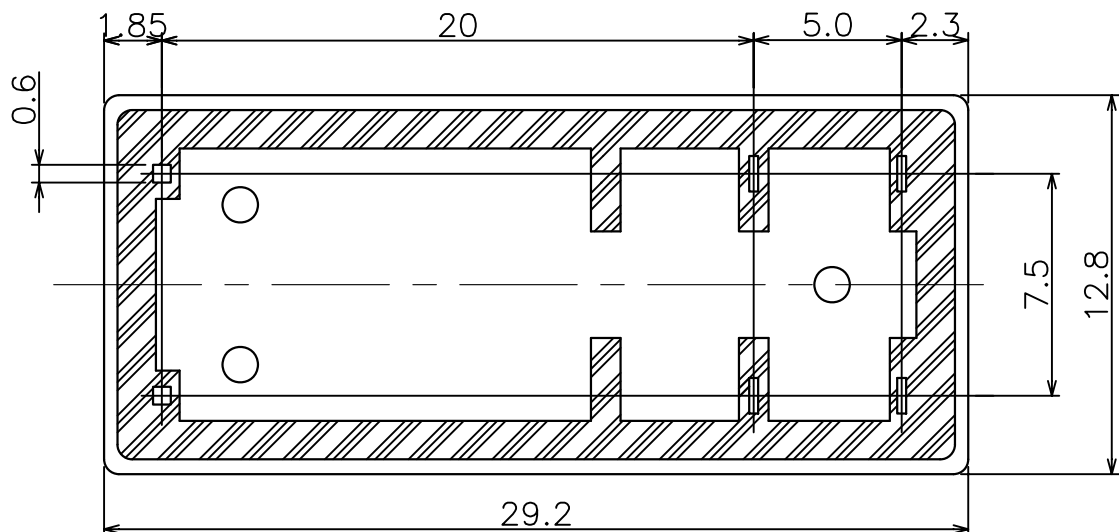

THIS DRAWING IS A CONTROLLED DOCUMENT.

DWN LIU, DAVEY 13MAY2009

CHK BANGHUA, YU

APVD SUNNY, ZHANG

PRODUCT SPEC

APPLICATION SPEC

WEIGHT

CUSTOMER DRAWING

Tyco Electronics Corporation



NAME

OZT-D/LM1 CUSTOMER DRAWING

SIZE

CAGE CODE

DRAWING NO

RESTRICTED TO

A3

00779

C=1461254-2

SCALE 4:1

SHEET 1 OF 2

REV E1

THIS DRAWING IS UNPUBLISHED. RELEASED FOR PUBLICATION
 © COPYRIGHT BY TYCO ELECTRONICS CORPORATION. ALL INTERNATIONAL RIGHTS RESERVED.

LOC	DIST	REVISIONS					
HB	-	P	LTR	DESCRIPTION	DATE	DWN	APVD
		A	-		-	-	-

107-79006	SUPERCED BY 1461392-8	9-1419145-2	OZT-SH-112LM1	OZT-SH-112LM1	12V	32
	ACTIVE	2-1419124-7	OZT-SH-124LM1	OZT-SH-124LM1	24V	31
	SUPERCED BY 3-1440002-8	3-1419124-4	OZT-SS-148LM1	OZT-SS-148LM1	48V	30
	OBSOLETE	3-1419124-3	OZT-SS-124LM1	OZT-SS-124LM1	24V	29
	OBSOLETE	3-1419124-1	OZT-SS-112LM1	OZT-SS-112LM1	12V	28
	ACTIVE	1-1461392-2	OZT-SH-148LM1	OZT-SH-148LM1	48V	27
	ACTIVE	1-1461392-1	OZT-SH-148DM1	OZT-SH-148DM1	48V	26
	ACTIVE	1-1461392-0	OZT-SH-124LM1	OZT-SH-124LM1	24V	25
	ACTIVE	1461392-9	OZT-SH-124DM1	OZT-SH-124DM1	24V	24
	ACTIVE	1461392-8	OZT-SH-112LM1	OZT-SH-112LM1	12V	23
	ACTIVE	1461392-7	OZT-SH-112DM1	OZT-SH-112DM1	12V	22
	ACTIVE	1461392-6	OZT-SH-109LM1	OZT-SH-109LM1	9V	21
	ACTIVE	1461392-5	OZT-SH-109DM1	OZT-SH-109DM1	9V	20
	ACTIVE	1461392-4	OZT-SH-106LM1	OZT-SH-106LM1	6V	19
	ACTIVE	1461392-3	OZT-SH-106DM1	OZT-SH-106DM1	6V	18
	ACTIVE	1461392-2	OZT-SH-105LM1	OZT-SH-105LM1	5V	17
	ACTIVE	1461392-1	OZT-SH-105DM1	OZT-SH-105DM1	5V	16
	ACTIVE	1-1461254-0	OZT-SS-148DM1	OZT-SS-148DM1	48V	15
	ACTIVE	1461254-9	OZT-SS-124DM1	OZT-SS-124DM1	24V	14
	ACTIVE	1461254-8	OZT-SS-109LM1	OZT-SS-109LM1	9V	13
	ACTIVE	1461254-7	OZT-SS-109DM1	OZT-SS-109DM1	9V	12
	ACTIVE	1461254-6	OZT-SS-106LM1	OZT-SS-106LM1	6V	11
	ACTIVE	1461254-5	OZT-SS-106DM1	OZT-SS-106DM1	6V	10
	ACTIVE	1461254-4	OZT-SS-105LM1	OZT-SS-105LM1	5V	9
	ACTIVE	1461254-3	OZT-SS-105DM1	OZT-SS-105DM1	5V	8
	ACTIVE	1461254-2	OZT-SS-112DM1	OZT-SS-112DM1	12V	7
	ACTIVE	1461254-1	OZT-SS-103DM1	OZT-SS-103DM1	3V	6
	ACTIVE	3-1440002-8	OZT-SS-148LM1	OZT-SS-148LM1	48V	5
ACTIVE	3-1440002-7	OZT-SS-124LM1	OZT-SS-124LM1	24V	4	
ACTIVE	3-1440002-6	OZT-SS-112LM1	OZT-SS-112LM1	12V	3	
SUPERCED BY 1-1461392-0	3-1440002-5	OZT-SH-124LM1	OZT-SH-124LM1	24V	2	
SUPERCED BY 1461392-8	3-1440002-4	OZT-SH-112LM1	OZT-SH-112LM1	12V	1	
PACKING SPEC.	PART STATUS	TE PART NO	DESCRIPTION	PART A	PART B	ITEM

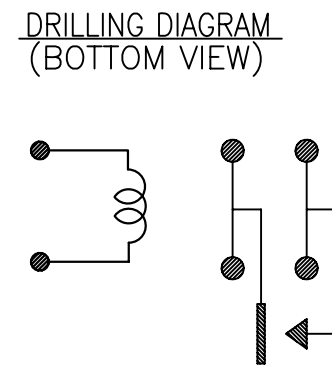
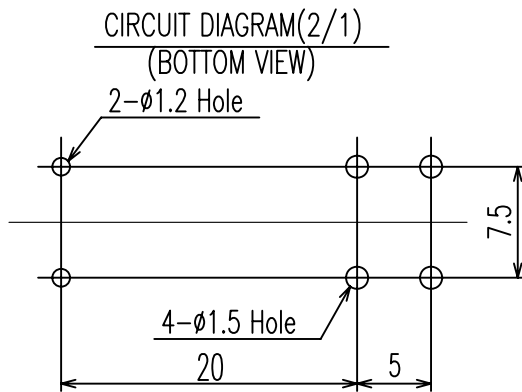

		UV RESIN	UV SEAL	16
		EPOXY RESIN	SEAL	15
		Cu ALLOY	HINGE SPRING	14
		PBT	CASE	13
		MW79	MAGNETIC WIRE	12
UL94V-0		PET	BASE	11
UL94HB		PBT	BOBBIN	10
	SOLDER DIP	Cu ALLOY	COIL TERMINAL	9
UL94V-0		PPS	CARD	8
		Ag ALLOY	MOVABLE CONTACT	7
		Ag ALLOY	STATIONARY CONTACT	6
	SOLDER DIP	Cu ALLOY	MOVABLE SPRING	5
	SOLDER DIP	Cu ALLOY	NO-TERMINAL	4
	Ni PLATED	STEEL	CORE	3
	Ni PLATED	STEEL	ARMATURE	2
	Ni PLATED	STEEL	YOKE	1
INCOMBUSTIBILITY	TREATMENT	MATERIAL	DESCRIPTION	ITEM

(E1) RELAY TYPE

THIS DRAWING IS A CONTROLLED DOCUMENT.

DWN	13MAY2009	Tyco Electronics Corporation	
CHK	-	Tyco Electronics	
APVD	-	NAME	
PRODUCT SPEC	-	OZT-D/LM1 CUSTOMER DRAWING	
APPLICATION SPEC	-	SIZE	RESTRICTED TO
WEIGHT	-	A3	-
CUSTOMER DRAWING	SCALE	CAGE CODE	DRAWING NO
	4:1	00779	1461254-2
	SHEET	REV	
	2 of 2	E1	