

PROD 4092 CODE	LOC DF	DIST SO	P	F	REVISIONS				
					ZONE	LTR	DESCRIPTION	DATE	APPD
					H		REV PER 0600-7522-98 CT	5-98	SS

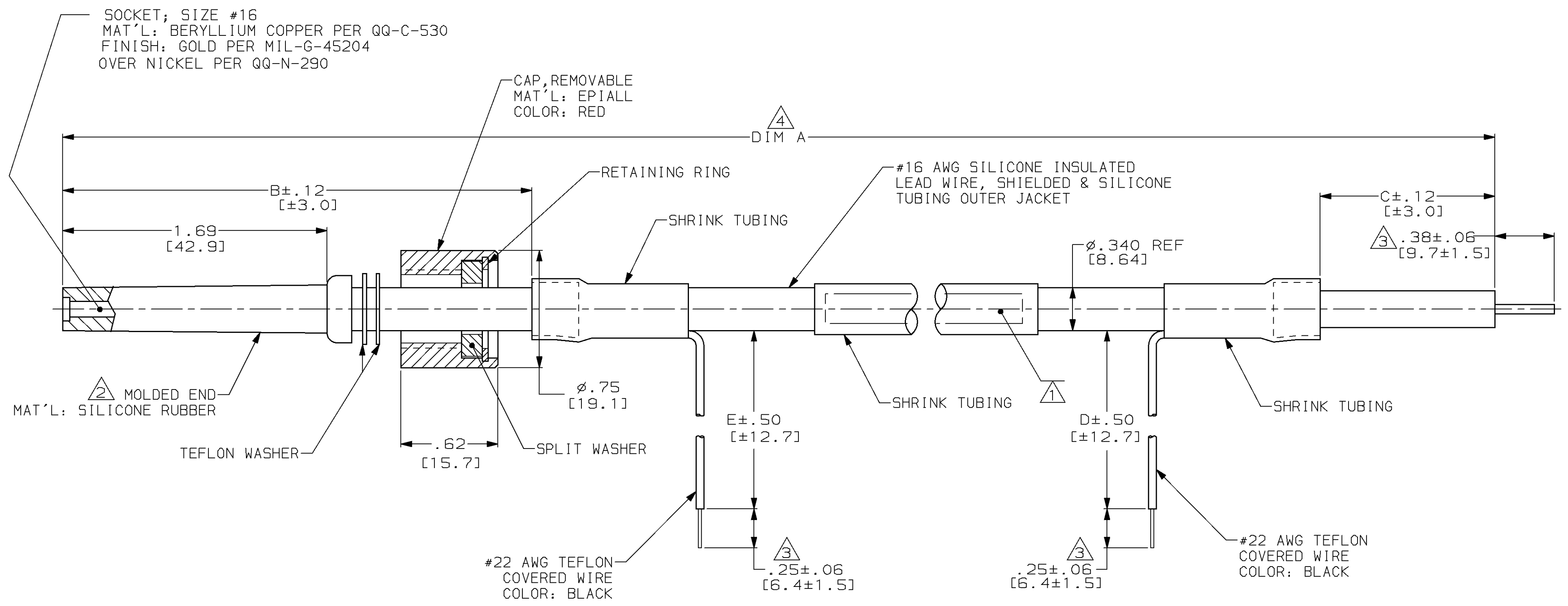

- 1 MARKED PER MIL-STD-130.
- 2 TO MATE WITH ANY AMP LGH-1L RECEPTACLE WITH A 1.69 [43.0] BARREL DEPTH.
- 3 PIG TAIL IS SOLDER DIPPED.
- 4 TOLERANCE: UP TO 24.00 [609.6] = ±.12 [±3.0]  
 24.00 [606.6] & UP = ±1%

6.00 [152.4]	-	6.00 [152.4]	3.00 [76.2]	130.00 [3302.0]	860446-9
6.00 [152.4]	-	13.00 [330.2]	3.00 [76.2]	150.00 [3810.0]	860446-8
6.00 [152.4]	-	10.00 [254.0]	3.00 [76.2]	157.00 [3987.8]	860446-7
6.00 [152.4]	-	35.00 [889.0]	3.00 [76.2]	128.00 [3251.2]	860446-6
6.00 [152.4]	-	24.00 [609.6]	3.00 [76.2]	50.00 [1270.0]	860446-5
6.00 [152.4]	-	13.00 [330.2]	3.00 [76.2]	36.00 [914.4]	860446-4
6.00 [152.4]	-	13.00 [330.2]	3.00 [76.2]	41.00 [1041.4]	860446-3
6.00 [152.4]	-	8.00 [203.2]	3.00 [76.2]	51.00 [1295.4]	860446-2
-	6.00 [152.4]	3.00 [76.2]	3.50 [88.9]	29.00 [736.6]	860446-1
DIM E	DIM D	DIM C	DIM B	DIM A	PART NUMBER

DO NOT SCALE PRINT. UNLESS SPECIFIED DIMENSIONS IN INCHES [mm] TOLERANCES ON: 2 PLC DEC ± .02 [0.5] 3 PLC DEC ± .015 [0.38] ANGLES ± -	DR 10-29-96 C.C. THOMAS	AMP Incorporated Harrisburg, PA 17105-3608		
MATERIAL SEE CALLOUTS	CHK 10-31-96 S. GLATFELTER			
FINISH SEE CALLOUTS	RLSE 10-31-96 C.C. THOMAS	PRODUCT SPEC	LEAD ASSY, SGL. END, LGH-1L WITH REMOVABLE CAP	
	APPLICATION SPEC	SIZE	CAGE CODE	DRAWING NO
		C	00779	C=860446
	WEIGHT -	SCALE	2:1	SHEET 1 OF 1

THIS DRAWING IS A CONTROLLED DOCUMENT FOR AMP INCORPORATED. IT IS SUBJECT TO CHANGE AND THE CONTROLLING ENGINEERING ORGANIZATION SHOULD BE CONTACTED FOR THE LATEST REVISION.