

THIS DRAWING IS UNPUBLISHED. RELEASED FOR PUBLICATION
 BY AMP INCORPORATED. ALL RIGHTS RESERVED.

LOC		DIST		REVISIONS			
P	LTR	DESCRIPTION	DATE	OWN	APVD		
BD	36	E	15 SEP 95	-	-		
		REDRAWN PER EC 0020-1178-94					

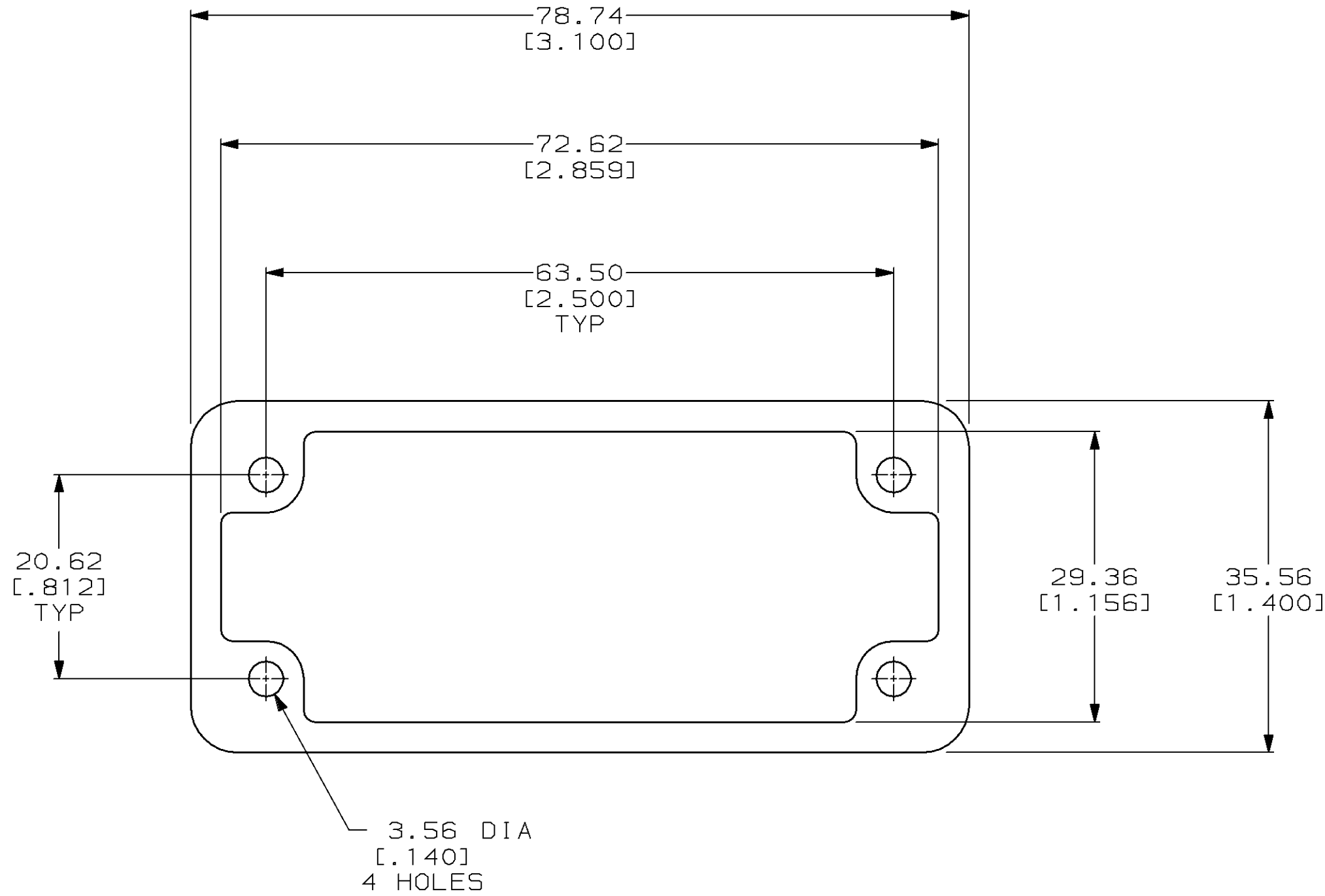

- ① 22 GA CARBON STEEL.
- ② 5.08µm [.000200] MIN NICKEL.

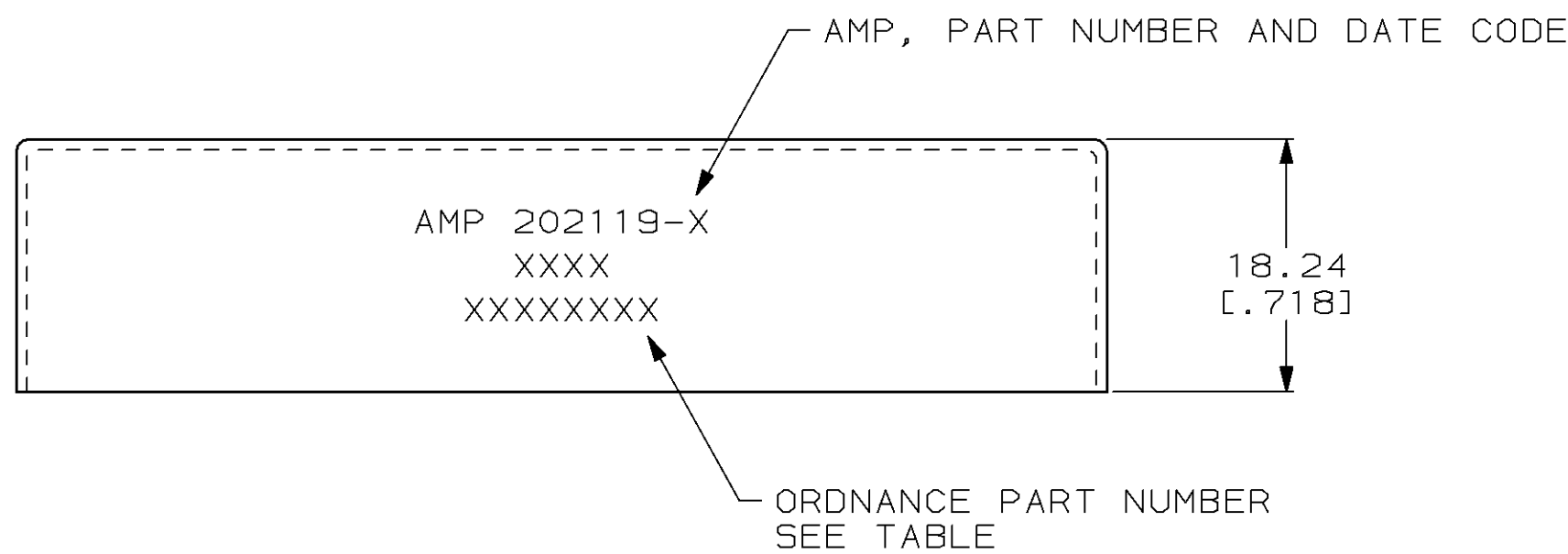

10187774	202119-3
-	202119-2
ORDNANCE PART NUMBER	PART NUMBER

<small>THIS DRAWING IS A CONTROLLED DOCUMENT FOR AMP INCORPORATED. IT IS SUBJECT TO CHANGE AND THE CONTROLLING ENGINEERING ORGANIZATION SHOULD BE CONTACTED FOR THE LATEST REVISION.</small>		DWN C. DORWART 15 SEP 95 CHK R. STONE 19 SEP 95 APVD G. STEINHAUER 05 OCT 95	AMP AMP Incorporated Harrisburg, PA 17105-3608
DIMENSIONS: mm [INCHES]	TOLERANCES UNLESS OTHERWISE SPECIFIED: 0 PLC ±- 1 PLC ±- 2 PLC ±0.38 [.015] 3 PLC ±- 4 PLC ±- ANGLES ±1°	PRODUCT SPEC APPLICATION SPEC	PIN HOOD, M SERIES
MATERIAL ①	FINISH ②	WEIGHT - CUSTOMER DRAWING	SIZE A2 CAGE CODE 00779 DRAWING NO C=202119 SCALE 2:1 SHEET 1 OF 1 REV E

202119

A