

THIS DRAWING IS UNPUBLISHED. RELEASED FOR PUBLICATION
 © COPYRIGHT - BY TYCO ELECTRONICS CORPORATION. ALL RIGHTS RESERVED.

LOC DW	DIST -	REVISIONS			
P	LTR	DESCRIPTION	DATE	DWN	APVD
	C	ECR-10-006310	23MAR10	AW	WK

NOTES:

- MATERIAL:
HOUSING: LCP WITH 30% GF, UL94 V-0, BLACK COLOR.
CONTACTS: PHOSPHOR BRONZE.
PEGS: BRASS.
- FINISH:
CONTACTS: GOLD PLATED (SEE TABLE) OVER 1.27µm [50µ"] MIN. NICKEL ON ENTIRE CONTACT.
PEGS: 2.54µm [100µ"] MIN. MATTE-TIN OVER 1.27µm [50µ"] MIN. NICKEL PLATED.
- REFLOW SOLDER CAPABLE TO 260°C PER TEC-109-201, CONDITION B.
- LATCH PART NUMBER: 1775338-1

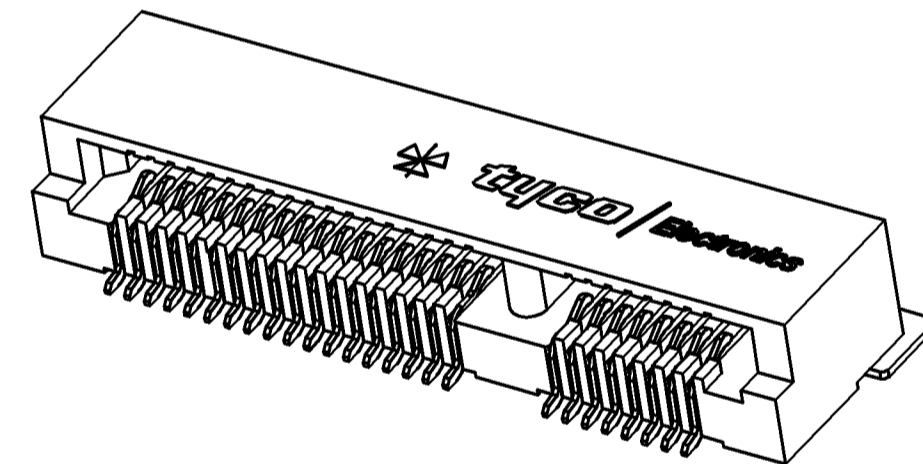
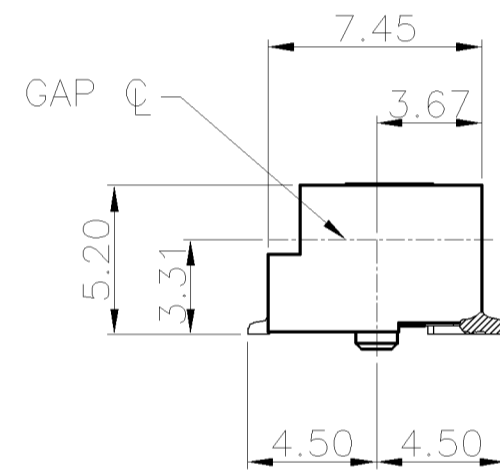
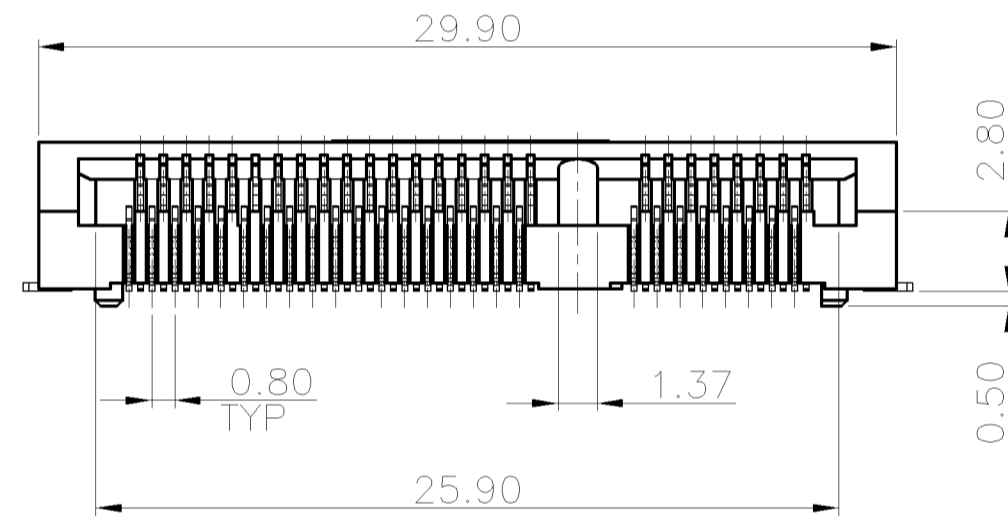
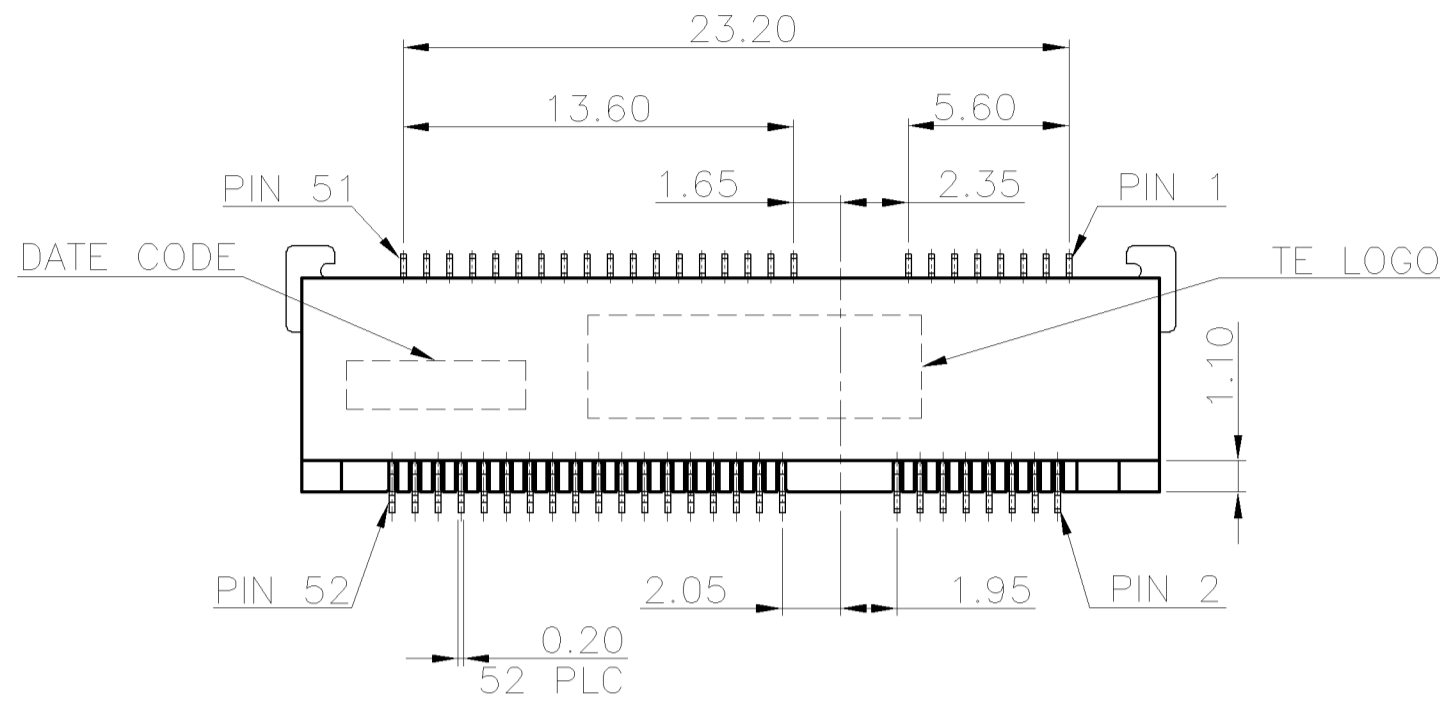

0.762µm [30µ"]	1775337-4
0.381µm [15µ"]	1775337-3
0.254µm [10µ"]	1775337-2
GOLD FLASH	1775337-1
MIN. GOLD THICKNESS	PART NUMBER

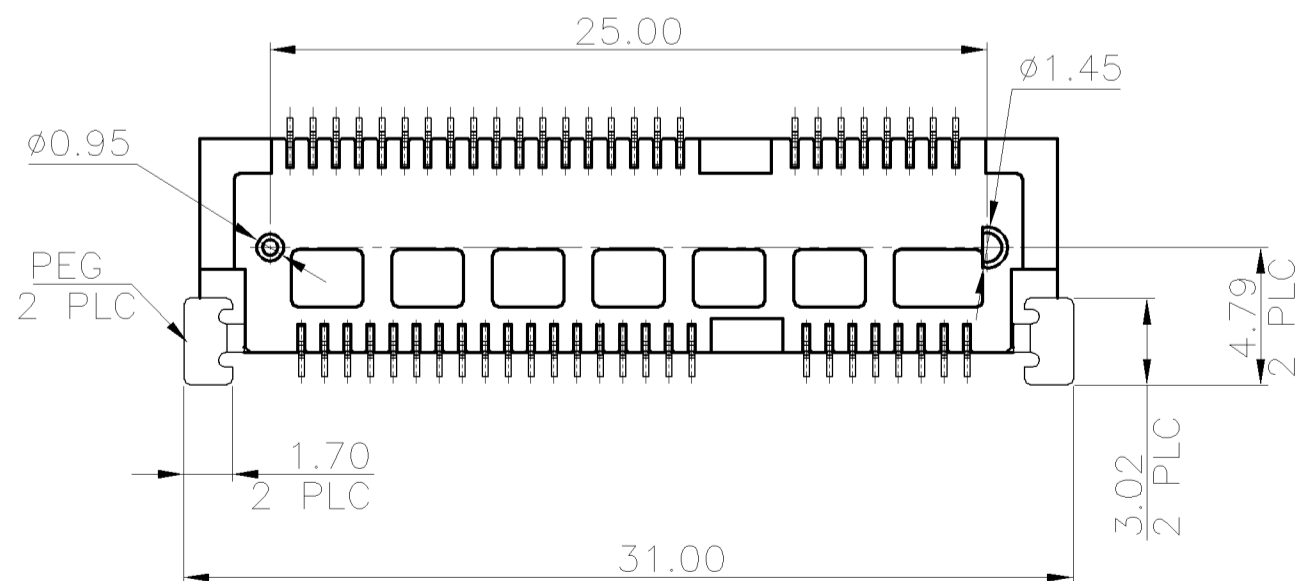

THIS DRAWING IS A CONTROLLED DOCUMENT.		DWN A. WU	30SEP2009	Tyco Electronics Corporation Taipei, Taiwan	
DIMENSIONS: MM		CHK S. CHIEN	30SEP2009	NAME	
TOLERANCES UNLESS OTHERWISE SPECIFIED:		APVD W. KODAMA	30SEP2009	PRODUCT SPEC	
0 PLC ± -		108-57508		APPLICATION SPEC	
1 PLC ± 0.3		-		SIZE	
2 PLC ± 0.2		-		CAGE CODE	
3 PLC ± 0.15		-		DRAWING NO	
4 PLC ± -		-		RESTRICTED TO	
ANGLES ± 3°		WEIGHT 1.67 GARMS		A300779	
MATERIAL SEE NOTE		FINISH SEE NOTE		G=1775337	
		CUSTOMER DRAWING		SCALE -	
				SHEET 1 OF 4	
				REV C	

THIS DRAWING IS UNPUBLISHED. RELEASED FOR PUBLICATION
 © COPYRIGHT BY TYCO ELECTRONICS CORPORATION. ALL RIGHTS RESERVED.

LOC	DIST	REVISIONS			
P	LTR	DESCRIPTION	DATE	DWN	APVD
		SEE SHEET 1.			

 SOLDERING AREA

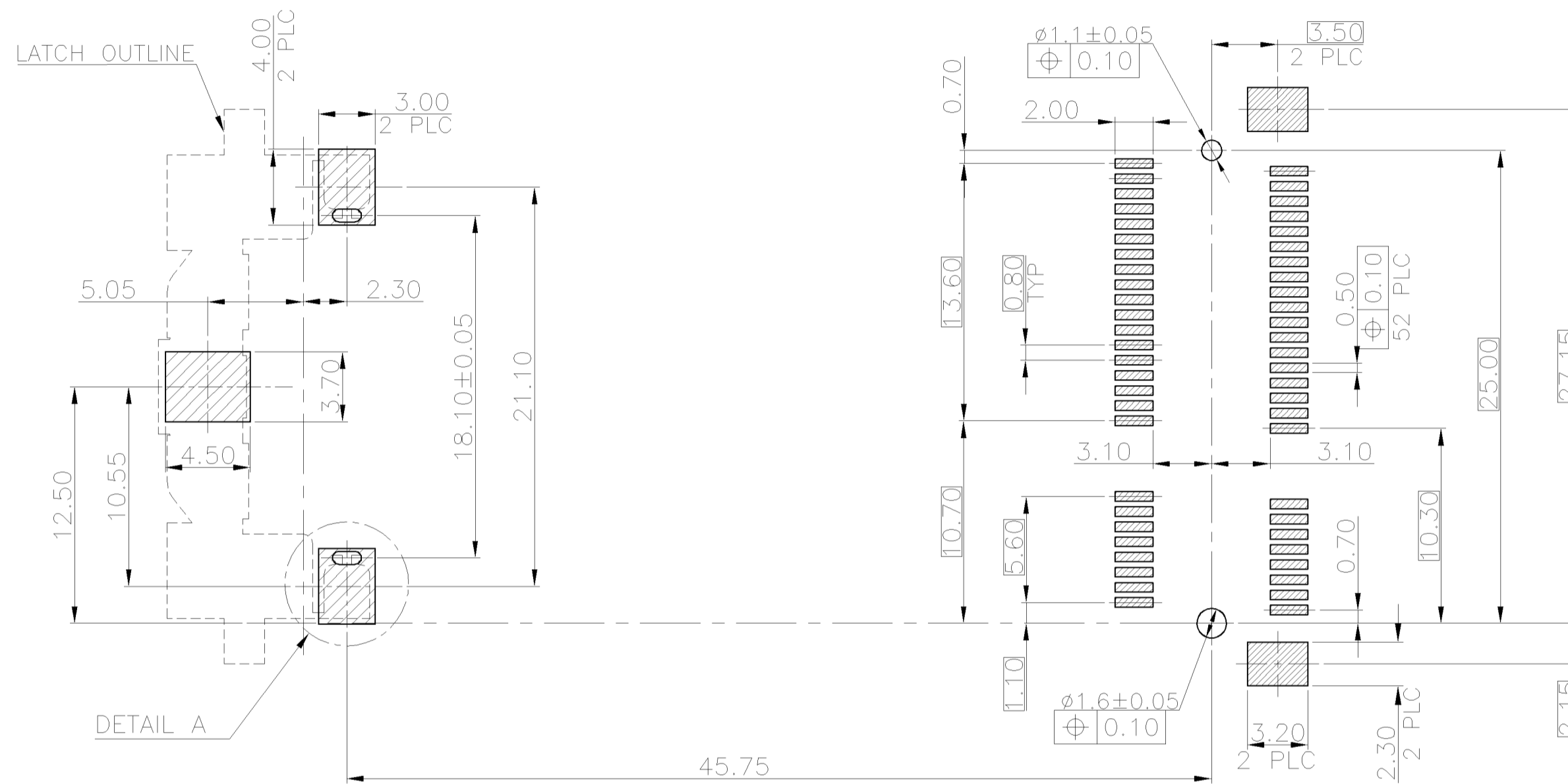

LATCH

CONNECTOR

TOLERANCE: ±0.05, THICKNESS: 1.0
RECOMMENDED ASSEMBLY PCB LAYOUT

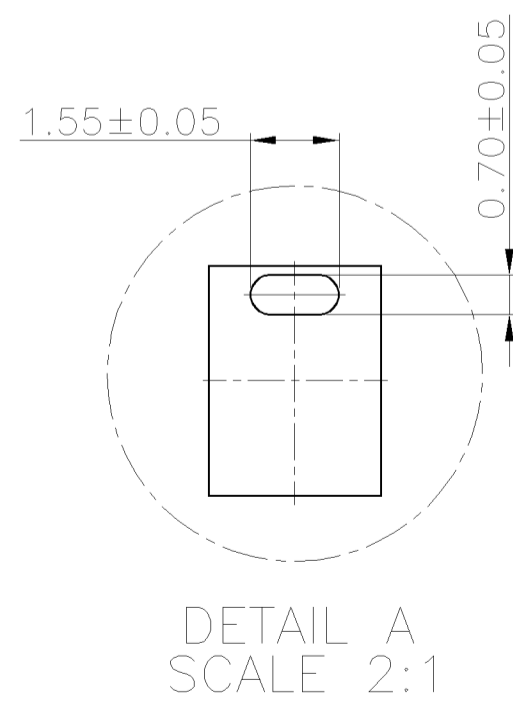

THIS DRAWING IS A CONTROLLED DOCUMENT.		DWN A. WU	30SEP2009	 Tyco Electronics Corporation Taipei, Taiwan	
DIMENSIONS: MM		CHK S. CHIEN	30SEP2009		
TOLERANCES UNLESS OTHERWISE SPECIFIED:		APVD W. KODAMA	30SEP2009	NAME	
0 PLC ± - 1 PLC ± - 2 PLC ± - 3 PLC ± - 4 PLC ± - ANGLES ± -		PRODUCT SPEC		MINI PCI EXPRESS, 52 POSITION, STANDARD TYPE, 5.2 HEIGHT	
MATERIAL		APPLICATION SPEC		SIZE	RESTRICTED TO
FINISH		WEIGHT		A3	—
CUSTOMER DRAWING				CAGE CODE	DRAWING NO
				00779	C=1775337
				SCALE	SHEET
				—	2 OF 4
				REV	C

4

3

2

1

THIS DRAWING IS UNPUBLISHED. RELEASED FOR PUBLICATION
© COPYRIGHT BY TYCO ELECTRONICS CORPORATION. ALL RIGHTS RESERVED.

LOC DW	DIST —	REVISIONS		
P	LTR	DESCRIPTION	DATE	DWN APVD
		SEE SHEET 1.		

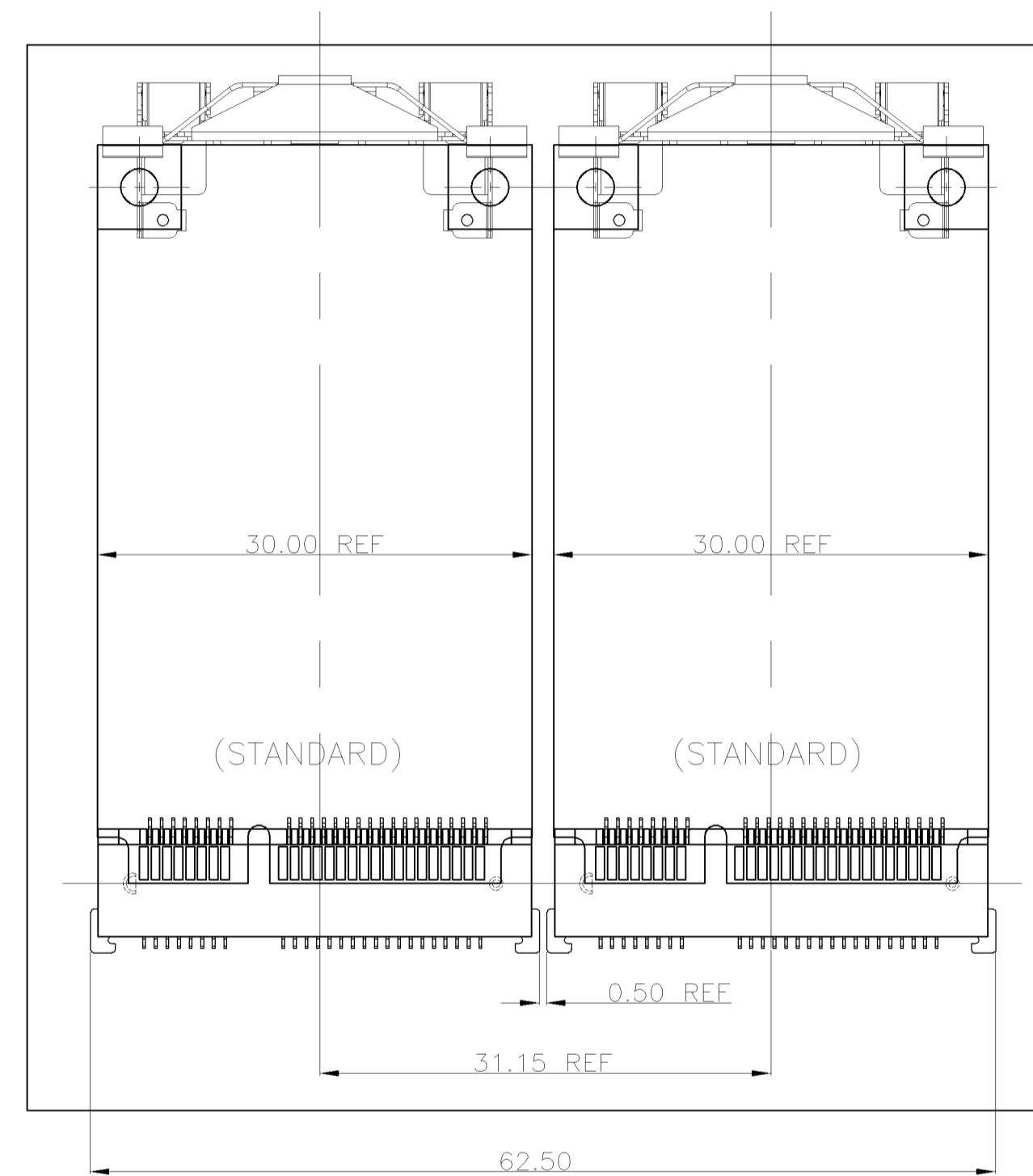
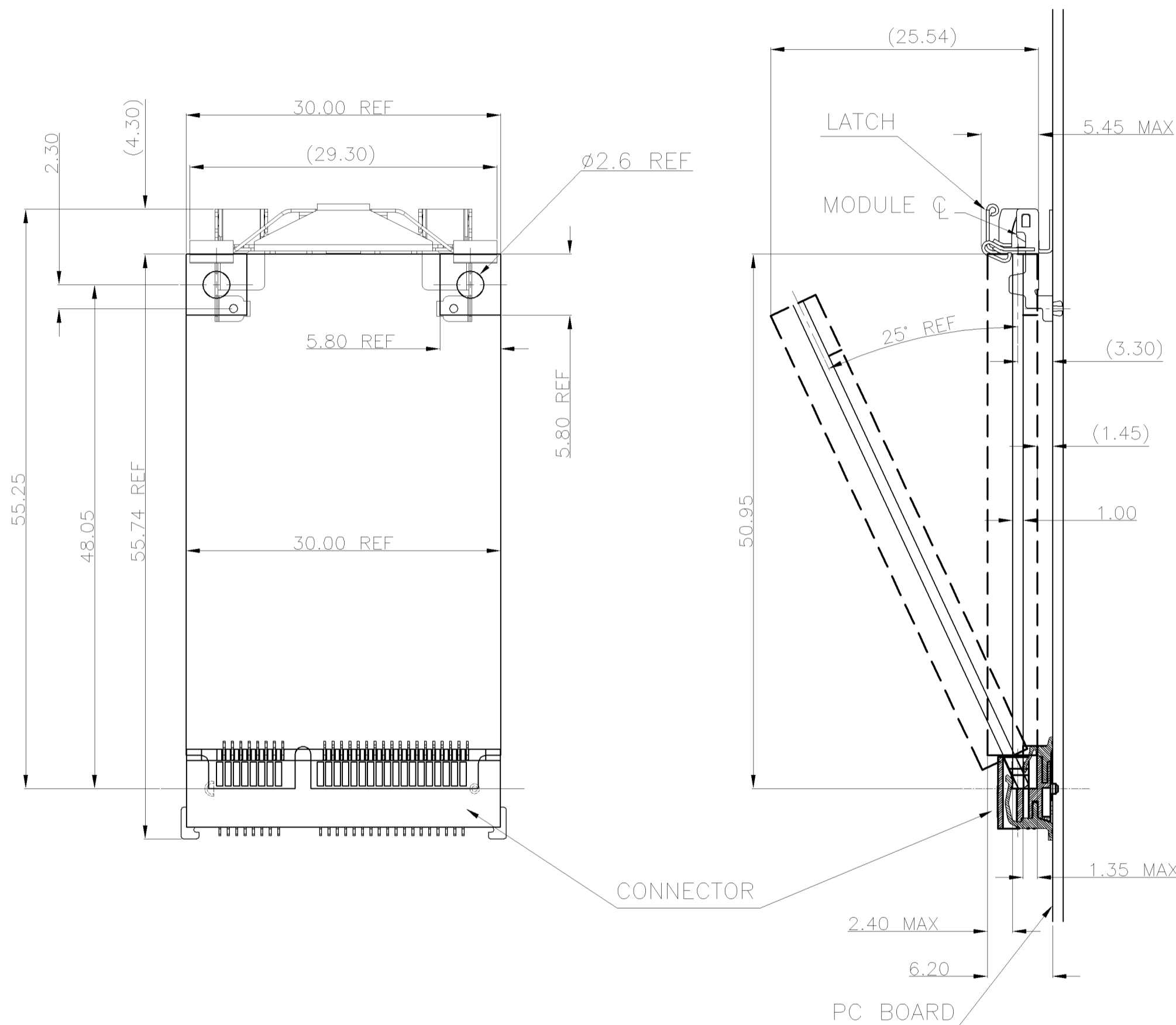

THIS DRAWING IS A CONTROLLED DOCUMENT.		DWN A. WU	30SEP2009	Tyco Electronics	Tyco Electronics Corporation	
DIMENSIONS: MM		CHK S. CHIEN	30SEP2009		Taipei, Taiwan	
TOLERANCES UNLESS OTHERWISE SPECIFIED:		APVD W. KODAMA	30SEP2009	NAME		
0 PLC ± -		PRODUCT SPEC		MINI PCI EXPRESS, 52 POSITION, STANDARD TYPE, 5.2 HEIGHT		
1 PLC ± -		APPLICATION SPEC				
2 PLC ± -		WEIGHT		SIZE	CAGE CODE	DRAWING NO
3 PLC ± -		CUSTOMER DRAWING		A3	00779	C=1775337
4 PLC ± -		SCALE		SHEET		RESTRICTED TO
ANGLES ± -		—		3 OF 4		REV C
FINISH		—				

4

3

2

1

THIS DRAWING IS UNPUBLISHED. RELEASED FOR PUBLICATION
 © COPYRIGHT BY TYCO ELECTRONICS CORPORATION. ALL RIGHTS RESERVED.

LOC	DIST	REVISIONS					
DW	—	P	LTR	DESCRIPTION	DATE	DWN	APVD
				SEE SHEET 1.			

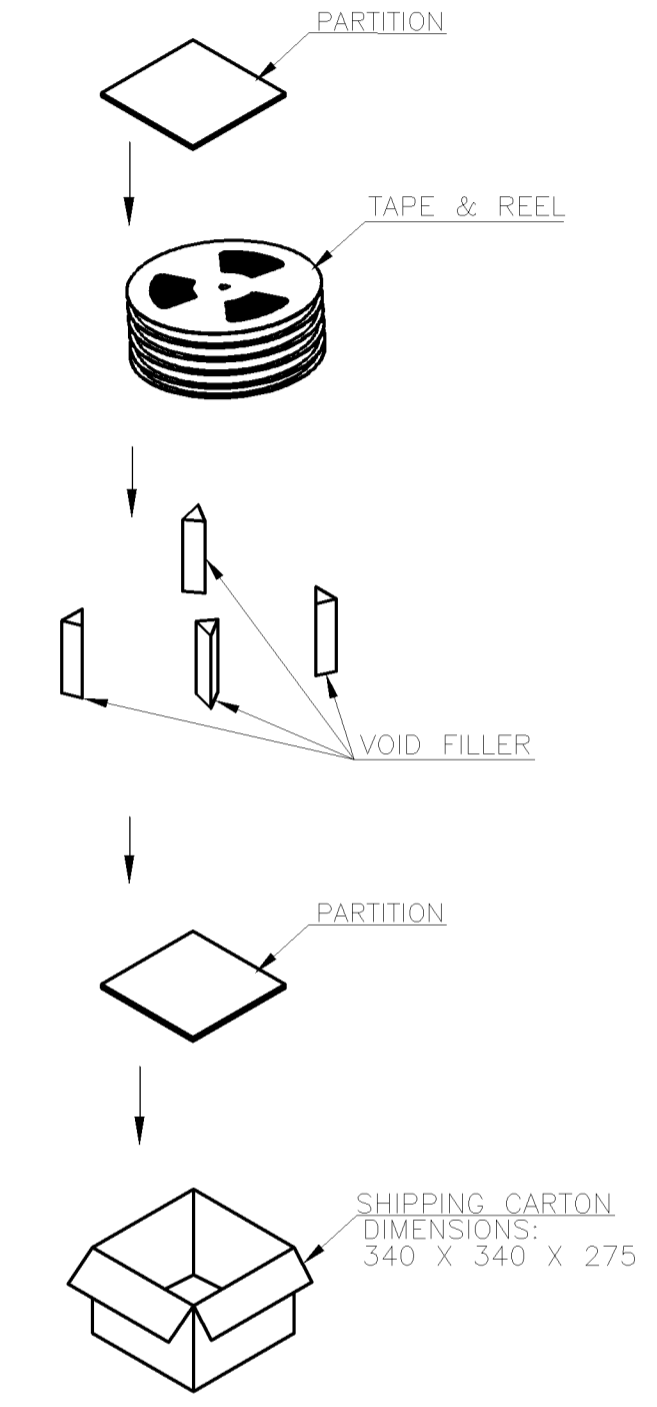
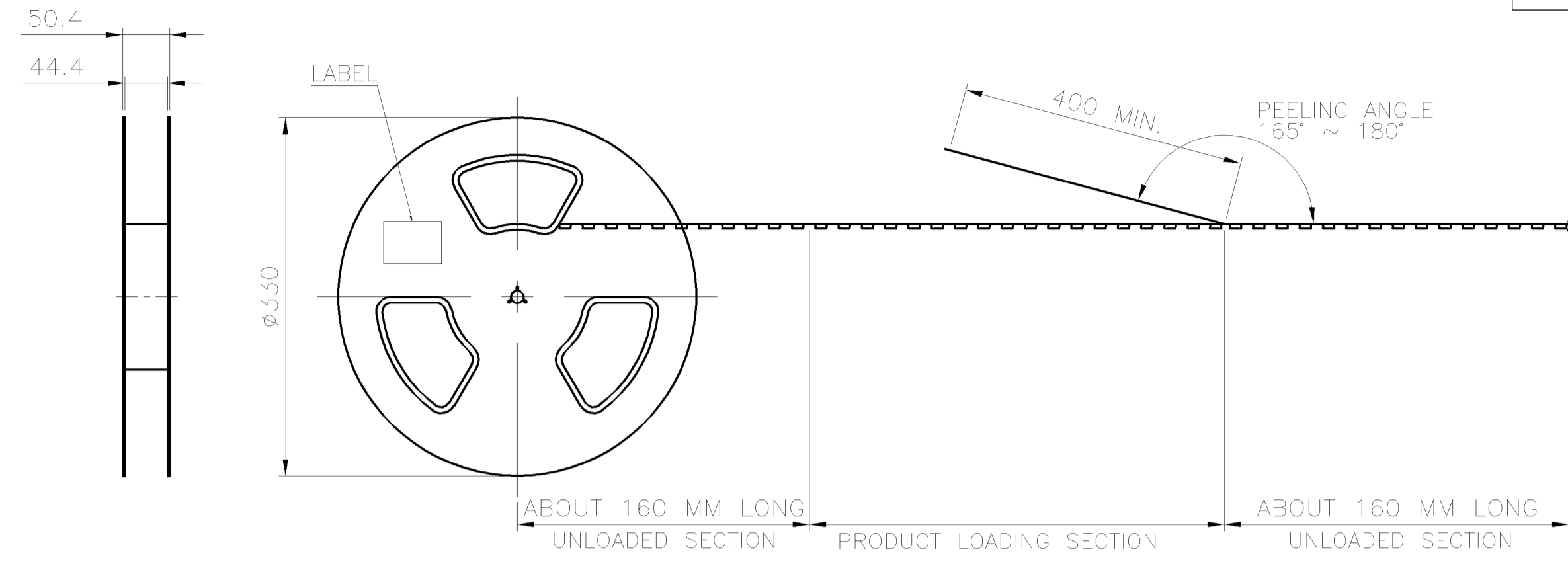

USER DIRECTION OF UNREELING →

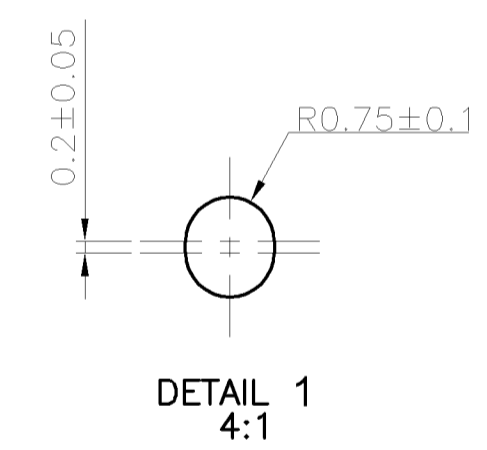
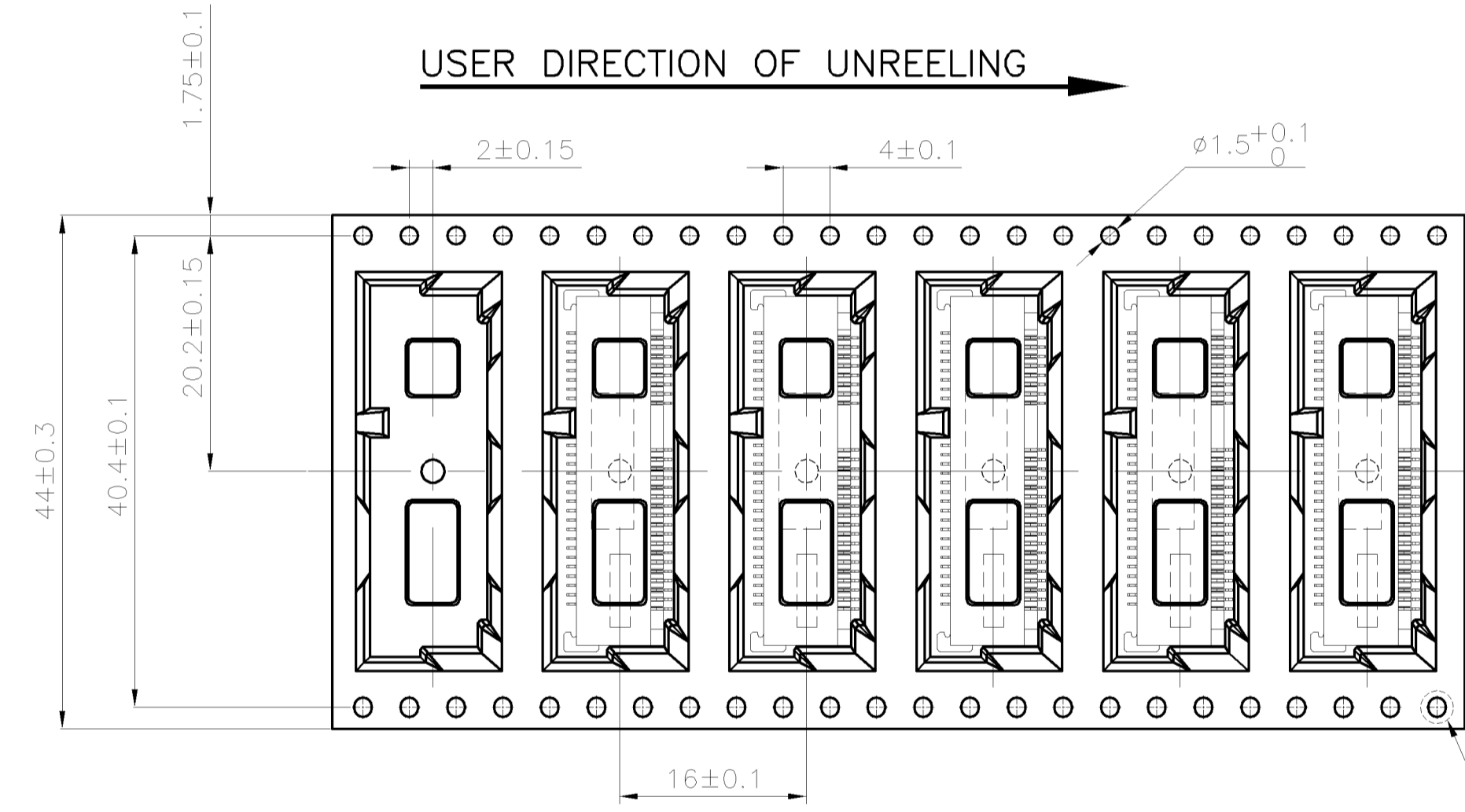

- NOTE:
- MATERIAL:
 BOX: FIBREBOARD, CORRUGATED, DOUBLE WALL.
 COVER TAPE: PET, HEAT-RESISTANT TEMPERATURE: 100°C, TRANSPARENT COLOR.
 CARRIER TAPE: POLYSTYRENES, HEAT-RESISTANT TEMPERATURE: 120°C, BLACK COLOR.
 REEL: POLYSTYRENES, HEAT-RESISTANT TEMPERATURE: 70°C, BLUE COLOR.
 BAG: POLYETHYLENE, HEAT-RESISTANT TEMPERATURE: 100°C.
 - PEELING STRENGTH: 0.1 ~ 1.3 N (10 ~ 130 GRAMS)
 - PEELING SPEED: 300 mm/min.
 - EACH BAG SHALL BE INCLUDED DESICCANT.

9.73 KG	5.02 KG	600	5	3000
GROSS WEIGHT	NET WEIGHT	PCS/TAPE	REELS/BOX	PCS/BOX

THIS DRAWING IS A CONTROLLED DOCUMENT.		DWN	A. WU	30SEP2009	Tyco Electronics Corporation Taipei, Taiwan			
		CHK	S. CHIEN	30SEP2009				
		APVD	W. KODAMA	30SEP2009	NAME			
		PRODUCT SPEC			MINI PCI EXPRESS, 52 POSITION, STANDARD TYPE, 5.2 HEIGHT			
		APPLICATION SPEC			SIZE	CAGE CODE	DRAWING NO	RESTRICTED TO
		WEIGHT			A3	00779	C=1775337	—
		CUSTOMER DRAWING			SCALE	SHEET	REV	
					—	4 OF 4	C	