

**MATERIALS**

SMA MALE BODY	PASSIVATED STAINLESS STEEL
SMA FEMALE	WHITE BRONZE PLATED BRASS
COUPLING NUT	WHITE BRONZE PLATED BRASS
INSULATOR	PTFE

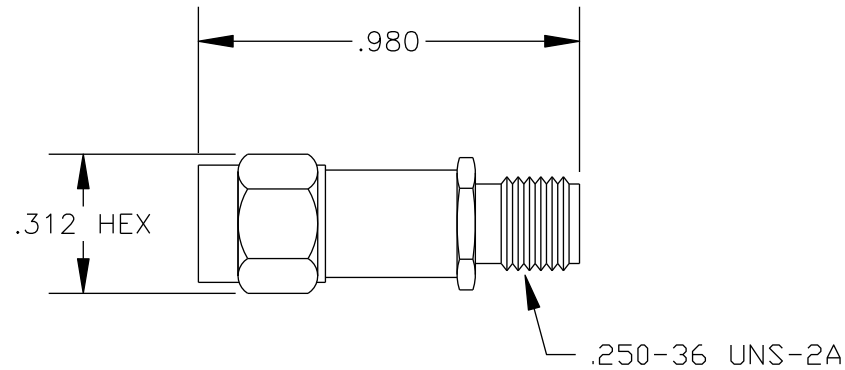

**SPECIFICATIONS**

FREQUENCY RANGE: DC TO 2 GHz  
 ATTENUATION: 40 dB  
 IMPEDANCE: 50 OHMS  
 ACCURACY: ±1.50 dB  
 VSWR: 1.20:1 MAXIMUM  
 AVG. POWER HANDLING CAPABILITY: 1 WATT



**PASTERNAK ENTERPRISES, INC.**  
 P.O BOX 16759, IRVINE, CA 92623  
 PHONE (949) 261-1920 FAX (949) 261-7451  
 WEB ADDRESS: [www.pasternack.com](http://www.pasternack.com)  
 E-MAIL ADDRESS: [sales@pasternack.com](mailto:sales@pasternack.com)  
**COAXIAL & FIBER OPTICS**

DWG TITLE		DES. SMA ATTENUATOR			
<b>PE7161-40</b>					
REV. -	<b>FSCM NO. 53919</b>	CAD FILE	112107	SCALE	N/A
		SIZE	A		127

- NOTES:**
- UNLESS OTHERWISE SPECIFIED ALL DIMENSIONS ARE NOMINAL.
  - ALL SPECIFICATIONS ARE SUBJECT TO CHANGE WITHOUT NOTICE AT ANY TIME.
  - DIMENSIONS ARE IN INCHES.