

MATERIALS	
BODY	PASSIVATED STAINLESS STEEL
CONTACT	GOLD PLATED
INSULATOR	PTFE

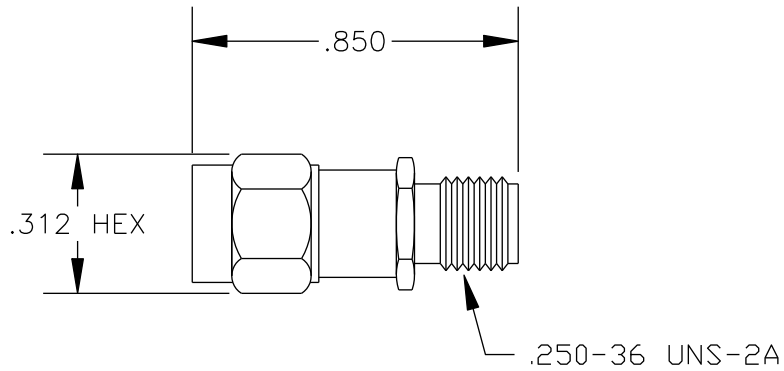

SPECIFICATIONS

FREQUENCY RANGE: DC TO 6 GHz
 ATTENUATION: 3 dB
 IMPEDANCE: 50 OHMS
 ACCURACY: ± 0.6 dB
 VSWR: 1.20:1 MAXIMUM
 AVG. POWER HANDLING CAPABILITY: 2 WATT



PASTERNAK ENTERPRISES, INC.

P.O BOX 16759, IRVINE, CA 92623
 PHONE (949) 261-1920 FAX (949) 261-7451

WEB ADDRESS: www.pasternack.com
 E-MAIL ADDRESS: sales@pasternack.com

COAXIAL & FIBER OPTICS

DWG TITLE

PE7162-3

DES. SMA ATTENUATOR

REV. - **FSCM NO. 53919**

CAD FILE 012308

SCALE N/A

SIZE A 127

NOTES:

1. UNLESS OTHERWISE SPECIFIED ALL DIMENSIONS ARE NOMINAL.
2. ALL SPECIFICATIONS ARE SUBJECT TO CHANGE WITHOUT NOTICE AT ANY TIME.
3. DIMENSIONS ARE IN INCHES.