

THIS DRAWING IS UNPUBLISHED. RELEASED FOR PUBLICATION
 © COPYRIGHT BY TYCO ELECTRONICS CORPORATION. ALL RIGHTS RESERVED.

LOC	DIST	REVISIONS					
		P	LTR	DESCRIPTION	DATE	DWN	APVD
HM	00		B	ECO-05-008509	06SEP2005	JM	MD
			C	REV ECO-08-004066	21FEB08	LH	BM
			D	REV ECO-08-011018	05MAY08	LH	BM

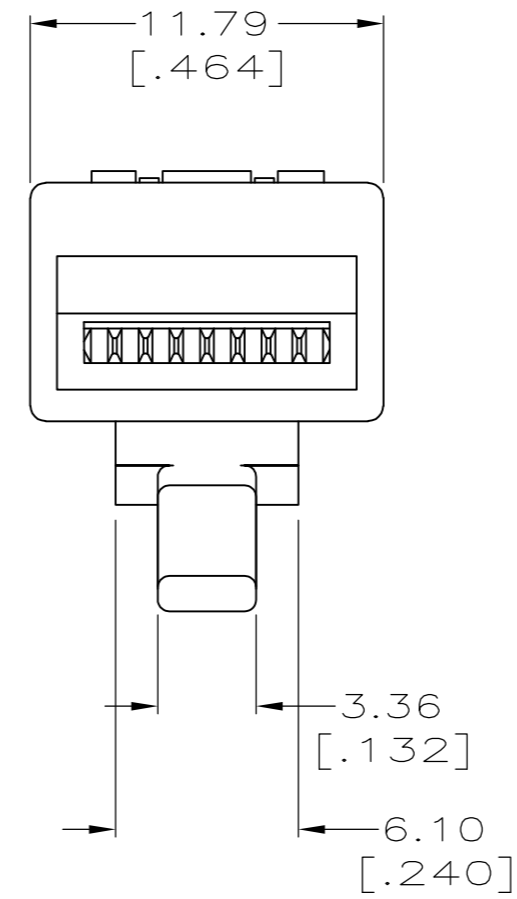
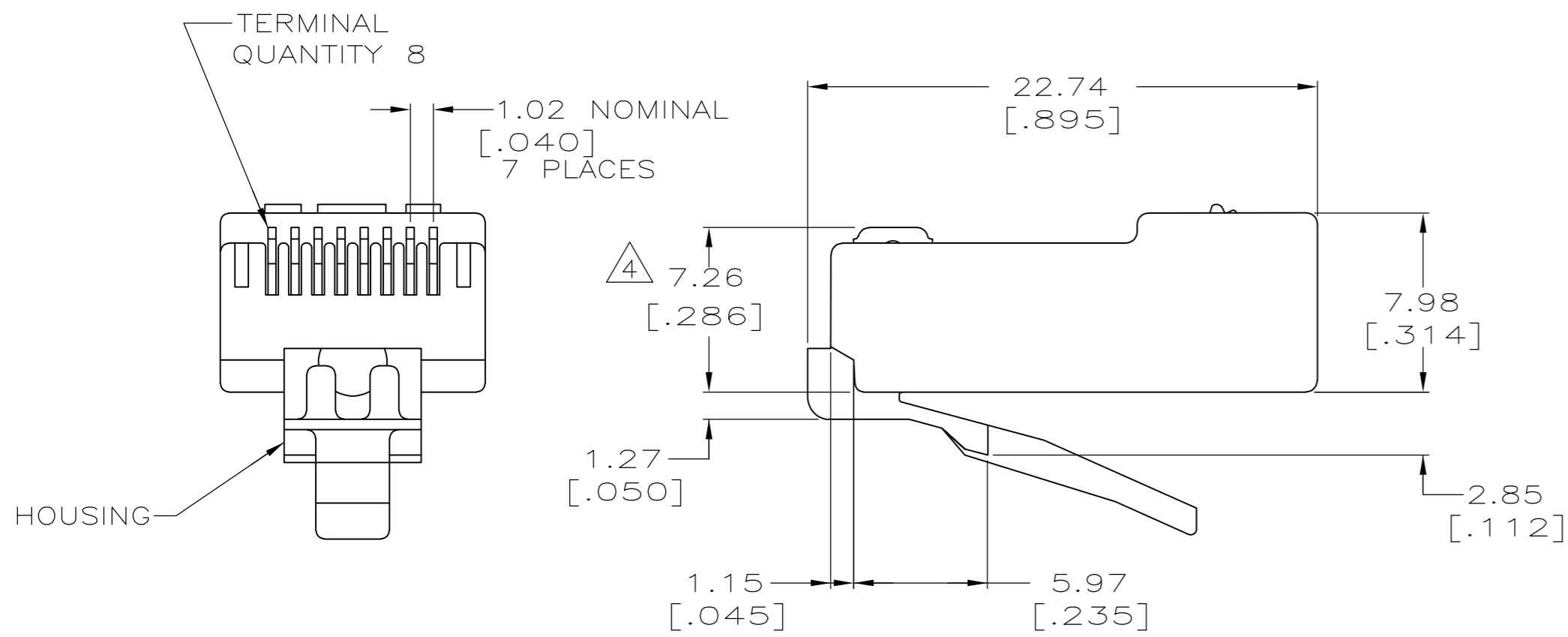
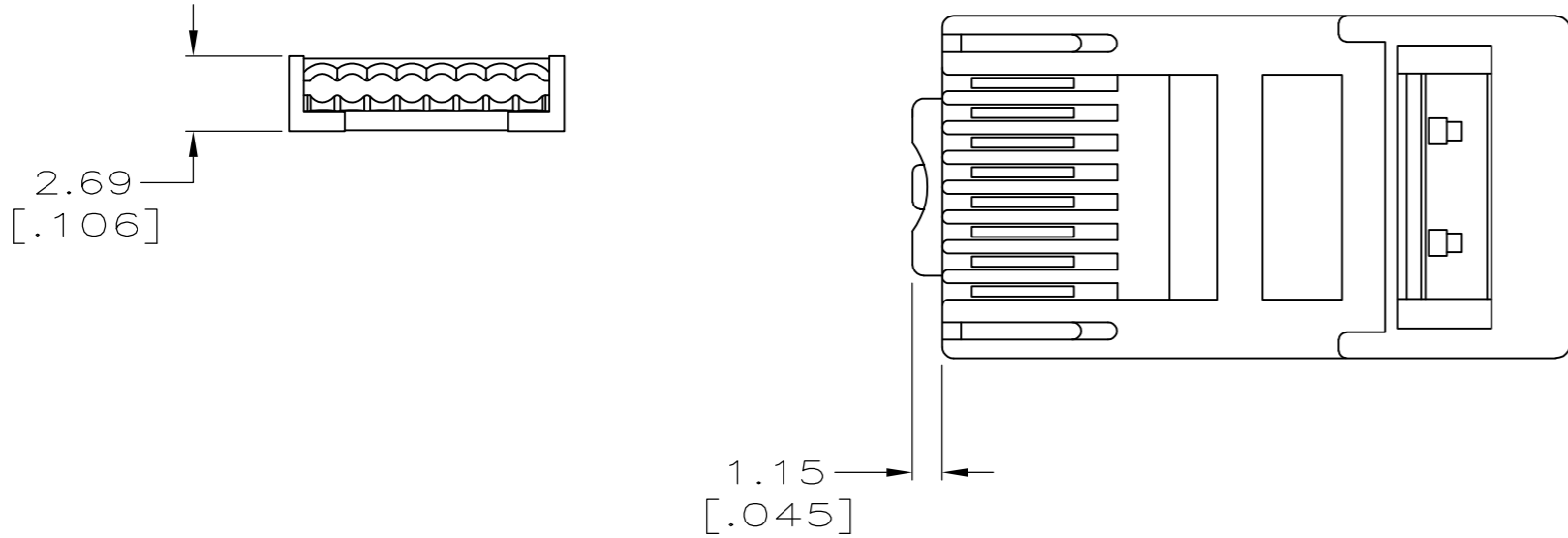
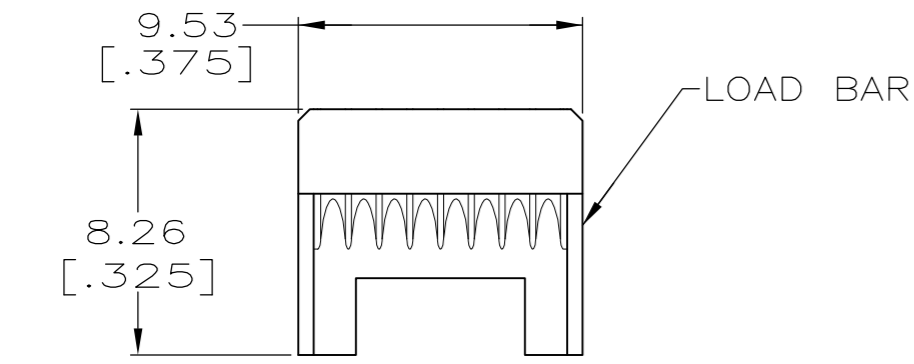

- 1 MATERIAL:
HOUSING - 94V-0 RATED POLYCARBONATE, CLEAR.
TERMINAL - 0.36[.014] THICK PHOSPHOR BRONZE PLATED WITH 1.27μm[.000050] MINIMUM THICK GOLD IN LOCALIZED AREA, GOLD FLASH OVER THE REMAINDER, OVER 2.54μm[.000100] MINIMUM THICK NICKEL UNDERPLATE.
LOAD BAR - PBT POLYESTER, BLACK.
- 2 DIMENSIONS ARE MAXIMUM UNLESS OTHERWISE SPECIFIED.
- 3. PLUG WILL ACCEPT A 24,26 OR 28 AWG SOLID CONDUCTOR, PROVIDED THE INSULATED CONDUCTOR DIAMETER IS 0.89[.035] TO 0.99[.039]; WITH AN UNSHIELDED, PLIABLE, LOOSE CABLE JACKET OF 4.83[.190] TO 5.59[.220] DIAMETER OR AN UNSHIELDED, RIGID, HARD CABLE JACKET OF 4.83[.190] TO 5.08[.200] DIAMETER.
- 4 TERMINATED DIMENSION 6.15[.242] MAXIMUM.
- 5 500 ASSEMBLIES AND 500 LOAD BARS PER PACKAGE.
- 6 100 ASSEMBLIES AND 100 LOAD BARS PER PACKAGE.
- 7 25 ASSEMBLIES AND 25 LOAD BARS PER PACKAGE.
- 8 10,000 ASSEMBLIES AND 10,000 LOAD BARS PER PACKAGE.
- 9. UL RECOGNIZED: FILE NUMBER E81956.

7	5-569278-4
6	5-569278-3
5	5-569278-2
8	5-569278-1
PACKAGED	PART NUMBER

THIS DRAWING IS A CONTROLLED DOCUMENT.		DWN DL DRUMMOND 5-22-95	Tyco Electronics Corporation Harrisburg, Pa 17105-3608	
DIMENSIONS: mm		CHK D. AHERON 5-22-95	NAME	
TOLERANCES UNLESS OTHERWISE SPECIFIED:		APVD E. LAURER 5-22-95	MODULAR PLUG ASSEMBLY, 8 POSITION, ROUND CABLE, SOLID WIRE	
0 PLC ± -	1 PLC ± -	PRODUCT SPEC	SIZE A2	CAGE CODE 00779
2 PLC ± -	3 PLC ± -	APPLICATION SPEC	DRAWING NO C=569278	RESTRICTED TO
4 PLC ± -	ANGLES ± -	WEIGHT -	SCALE 4:1	SHEET 1 OF 1
MATERIAL	FINISH	CUSTOMER DRAWING	REV D	