

NOTE



All numerical values are in metric units [with U.S. customary units in brackets]. Dimensions are in millimeters [and inches]. Unless otherwise specified, dimensions have a tolerance of ± 0.13 [$\pm .005$] and angles have a tolerance of $\pm 2^\circ$. Figures and illustrations are for identification only and are not drawn to scale.

1. INTRODUCTION

This specification covers the requirements for application of Series 062 (F2 and F) Bus Bar Connectors for the power electronics distribution system (PEDS). These connectors are designed to engage 1.58 [.062] thick power bus bars. Series 062F2 connectors have mounting flanges in-line (180°) with the bus bar slot. Series 062F connectors have mounting flanges at a right angle (90°) to the bus bar slot.

Each connector consists of a contact with spring members and an anti-overstress guide plate. They are designed to be attached to the bus bar or mounting plane with nuts and bolts tightened to a pre-determined torque.

When corresponding with personnel, use the terminology provided in this specification to facilitate your inquiries for information. Basic terms and features of this product are provided in Figure 1.

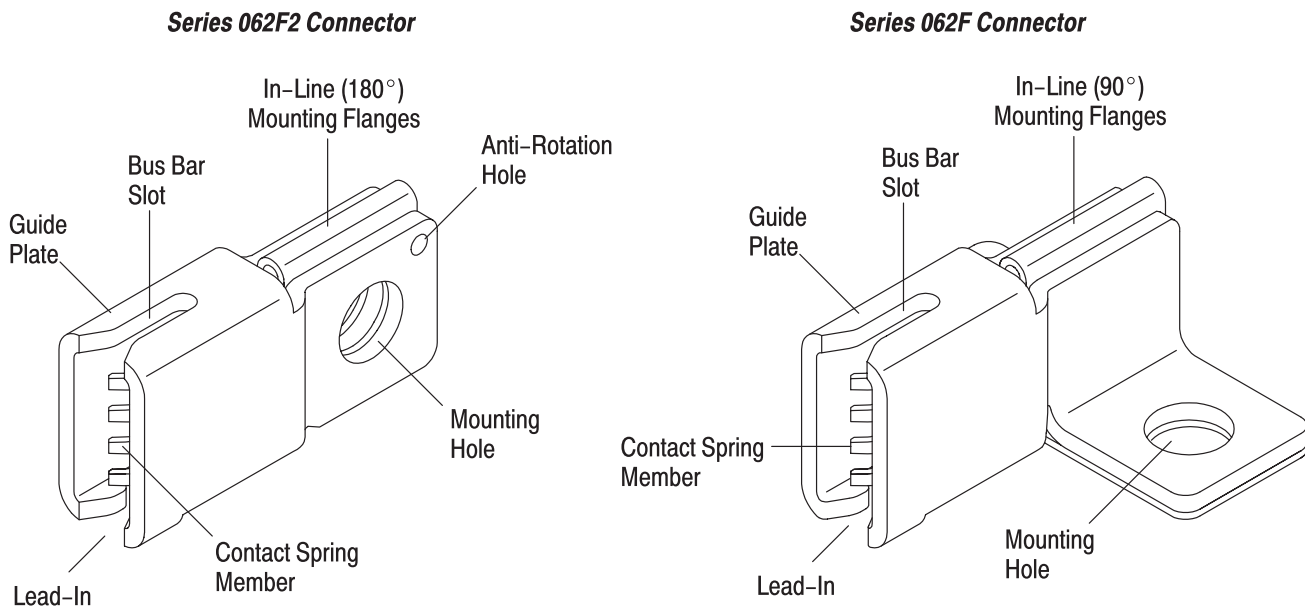

Figure 1

2. REFERENCE MATERIAL

2.1. Revision Summary

Revisions to this application specification include:

- Updated document to corporate requirements
- Corrected nickel plating finish thickness in Paragraph 3.6A

2.2. Customer Assistance

Reference Product Base Part Number 104729 and Product Code 1080 are representative of Series 062 Bus Bar Connectors. Use of these numbers will identify the product line and expedite your inquiries through a service network established to help you obtain product and tooling information. Such information can be obtained through a local Representative or, after purchase, by calling PRODUCT INFORMATION at the number at the bottom of page 1.

2.3. Drawings

Customer Drawings for product part numbers are available from the service network. If there is a conflict between the information contained in the Customer Drawings and this specification or with any other technical documentation supplied, call PRODUCT INFORMATION at the number at the bottom of page 1.

2.4. Specifications

Product Specification 108–1380 provides product performance and test information.

Finish Specifications (112–Series) provide quality assurance and technical requirements which describe a finish applied to a material. Specifications available that pertain to this product are:

- 112–32 Electrodeposited Silver Plating
- 112–25 Electrodeposited Nickel Plating

3. REQUIREMENTS

3.1. Limitations

A. Safety

Safety interlocks and/or insulating devices must be designed into the system in which the connector will be installed to avoid inadvertent electrical shock to the installer and equipment operator.



To avoid shock or electrocution, the electrical system must be de-energized BEFORE installing or removing a connector, AND BEFORE mating and unmating the connector with the bus bar.

B. Chemical Exposure

The connectors are not intended for concentrated sulfur- or chlorine-bearing atmospheres.

3.2. Mounting Hole Layout



The mounting hole plane, bus bar, and mounting hardware must be galvanically compatible with the stainless steel guide plate and the silver-plated copper contact.

Slotted pins are recommended as the anti-rotational devices for Series 062F2 connectors. The mounting holes in the mounting plane must be configured according to and must be within the tolerances provided in Figure 2.

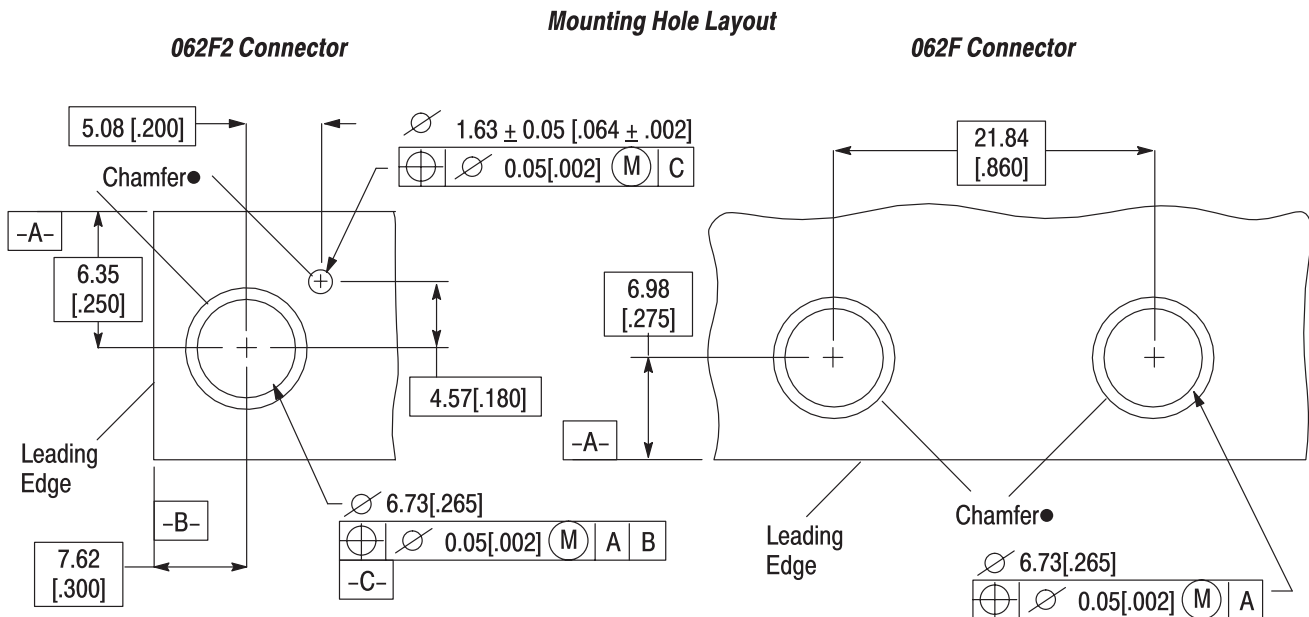

- All holes must be chamfered 0.76 [.030] × 45° on both sides of mounting plane.

Figure 2

3.3. Clearance

Clearance is required between connectors on the mounting plane, connectors passing through a panel, encasement, or backplane, and for bus bar engagement.

A. Between Connectors on Mounting Plane

A minimum clearance between contacts is essential to prevent interference between circuits. See Figure 3.

Required Clearance Between Connectors on Mounting Plane

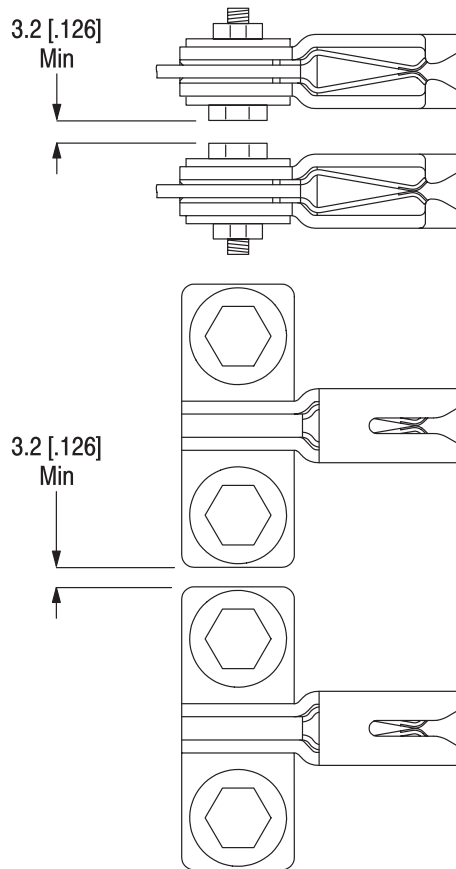

Figure 3

B. Between Cutout and Bus Bar

If the connector will be passing through a panel, casting, pc board, or some other type of encasement, the opening must be large enough to allow clearance for the connector and for the connector to engage the bus bar at the full depth. See Figure 4.

3.4. Polarization and Keying

The connectors are not designed with polarization or keying to allow for greater versatility of applications. If polarization or keying is desired, it must be a feature designed into the system.

Required Clearance for Cutout and Bus Bar

062F2 Connector

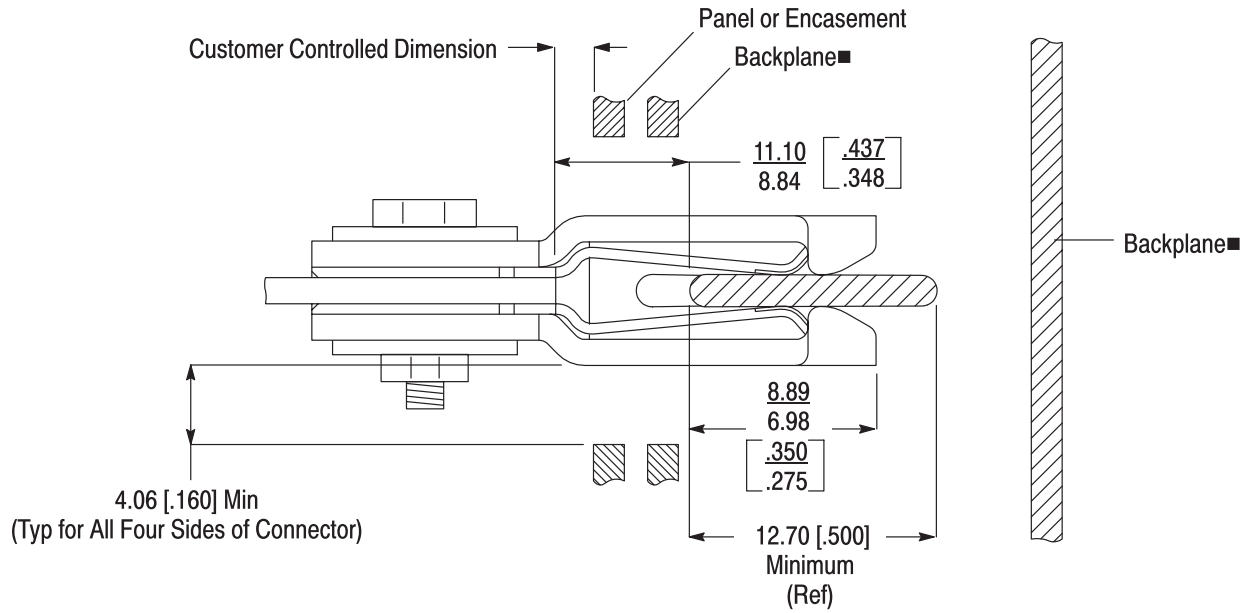

062F Connector

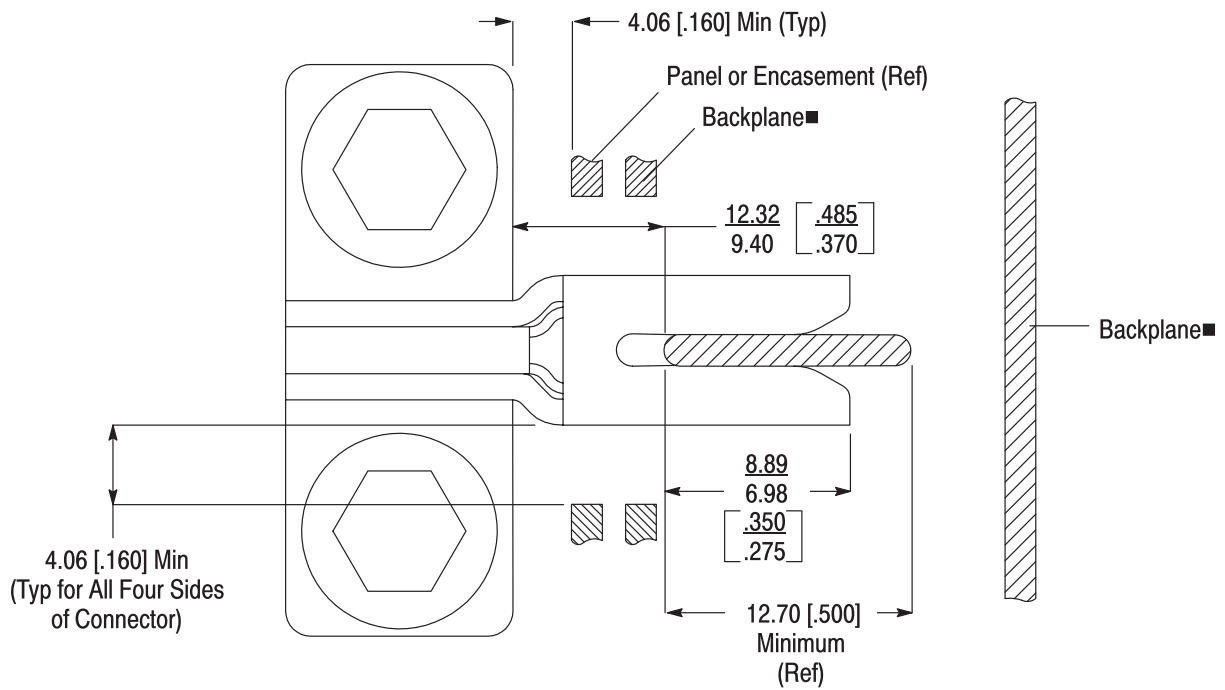

- The backplane may be in front or in back of the bus bar. If in front, a cutout must be made in the backplane with the same clearances specified for a panel or encasement.

Figure 4

3.5. Mounting Hardware

All hardware must be stainless steel and supplied by the customer. The primary recommendation for attaching connectors to a bus bar is to use 1/4-inch bolts, washers, lockwashers, and nuts, and a slotted pin to prevent rotation when installing 062F2 (in-line) connectors. See Figure 5.



All recommended hardware is commercially available. The washers and lockwashers will ensure a secure connection that will not loosen as a result of heat, vibration, handling of equipment, etc.

062F2 Connector

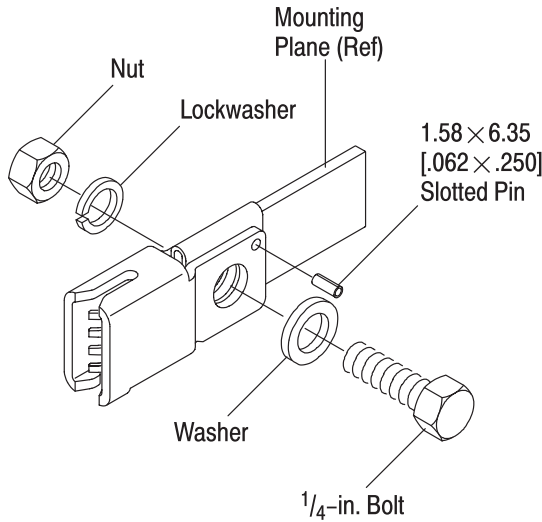

062F Connector

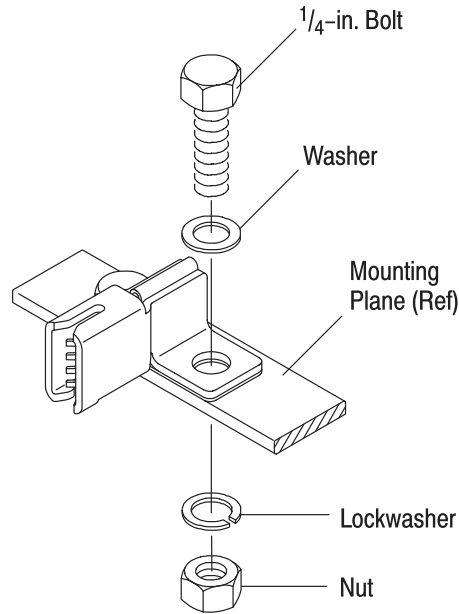

Figure 5

3.6. Bus Bar

A. Material

For optimum performance, the bus bar must be made of highly conductive copper (101% @ 20°C [68°F] per International Anneal Copper Standards (IACS), silver plated with a thickness of 0.00635 to 0.00889 [.000250 to .000350] over 0.00127 to 0.00254 [.00005 to .00010] nickel plating, and lubricated with MS-181N (product of Miller-Stephenson Chemical Co. Inc.) or equivalent.

The bus bar **MUST NOT** be made of aluminum, nor may it be tin plated.



For additional material information, refer to 112-32 for silver plating, 112-25 for nickel plating, and the IACS for copper material.

B. Finish

The finished surface of the bus bar must be from 0.40 to 0.80 μm [16 to 32 microinch].

C. Design

The bus bar must be rigidly constructed and capable of preventing movement that could cause stubbing or misalignment of the contact with the bus bar. The leading edge must have a full radius or a gradual taper to provide a lead-in and ease in mating of the connector with the bus bar. The thickness and width of the bus bar must be within the dimension given in Figure 6. The bus bar must be capable of engaging the contact over the full height of the contact no more than the dimension given in Figure 6.

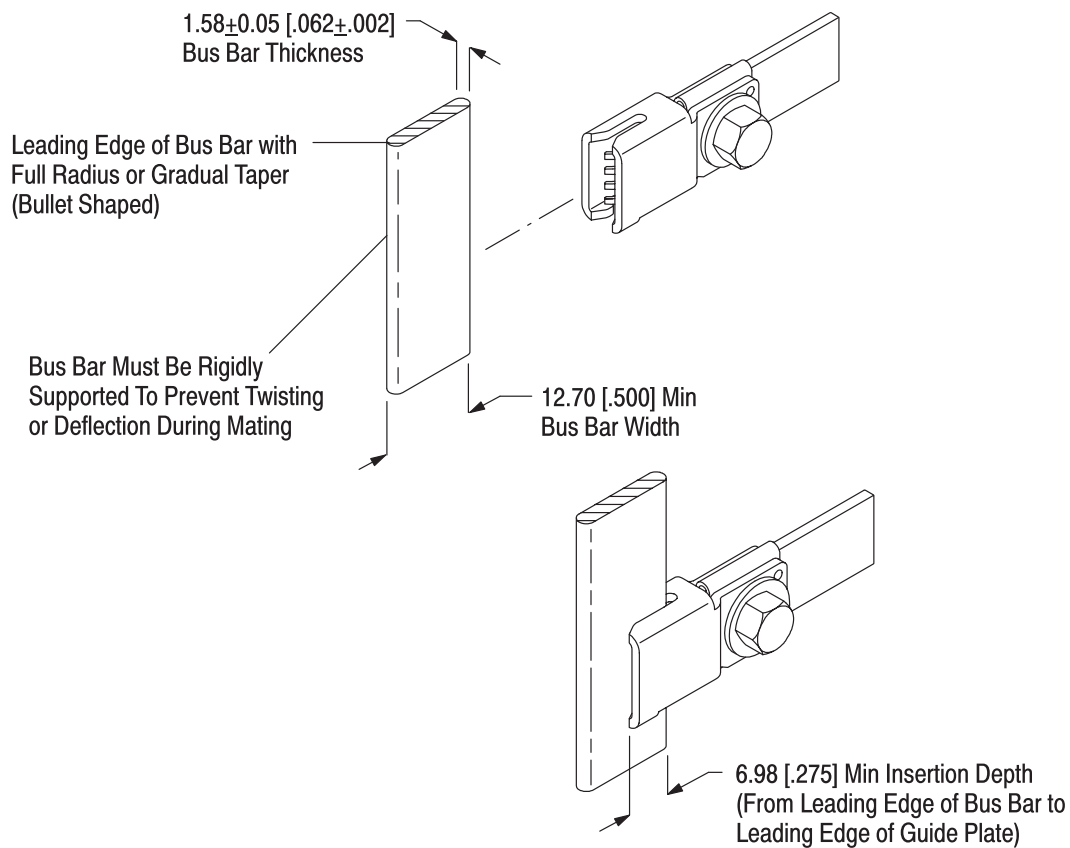

Figure 6

D. Straightness

The perpendicularity of the bus bar from the center of the contact to either end must be within the tolerance shown in Figure 7.

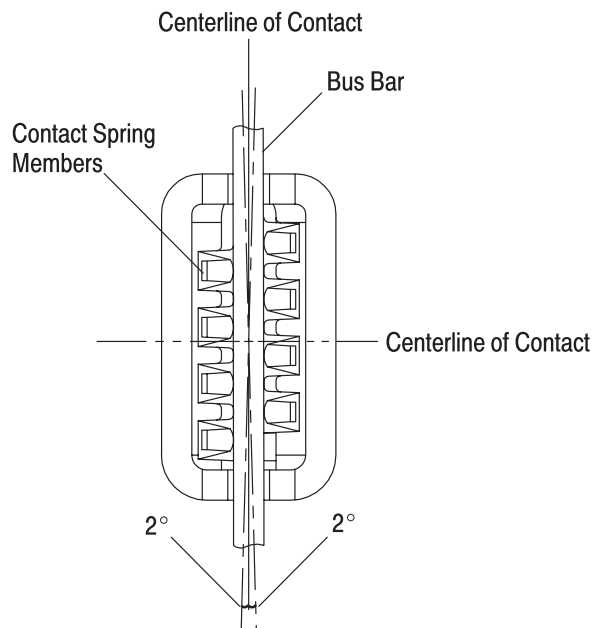

Figure 7

3.7. Ancillary Items

A. Stabilizer

A locking or fastening device must be used to stabilize the connector at the proper insertion depth and to prevent movement of the connector.

B. Movable Mounts

Drawer, panel, and other movable mounts must have a misalignment tolerance of ± 0.508 [± 0.020] for the contact. The guide plate can correct misalignment up to a tolerance of ± 1.52 [± 0.060] if the power supply module weighs less than 45.36 kg [100 lbs] and adequate mechanical devices are used to prevent deflection of the bus bar and distortion of the mounting plane.

3.8. Repair

These connectors are not repairable. Damaged or defective connectors must not be used.

4. QUALIFICATION

Series 062 Bus Bar Connectors are listed by Underwriter's Laboratories, Inc. (UL) under File E113407.

5. TOOLING

The only tooling required is a good quality commercially available wrench used to secure connector mounting hardware.

6. VISUAL AID

The illustration below shows a typical application of Series 062 Bus Bar Connectors. This illustration should be used by production personnel to ensure a correctly applied product. Applications which DO NOT appear correct should be inspected using the information in the preceding pages of this specification and in the instructional material shipped with the product or tooling.

SERIES 062F2 CONNECTOR

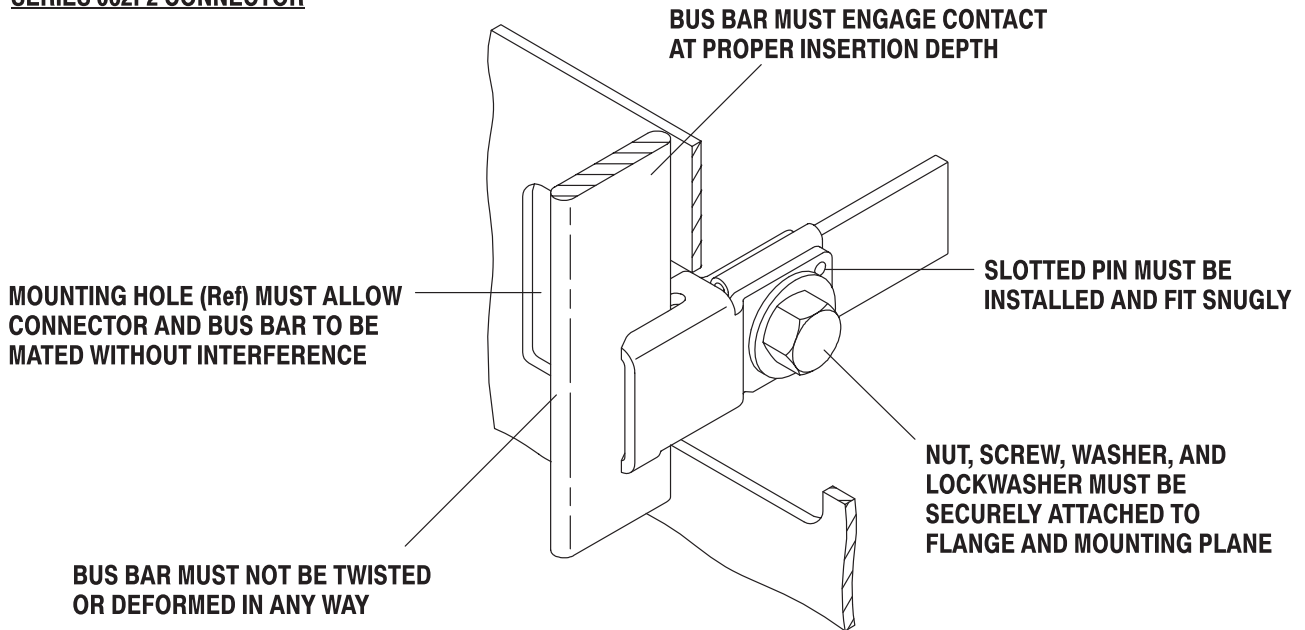

SERIES 062F CONNECTOR

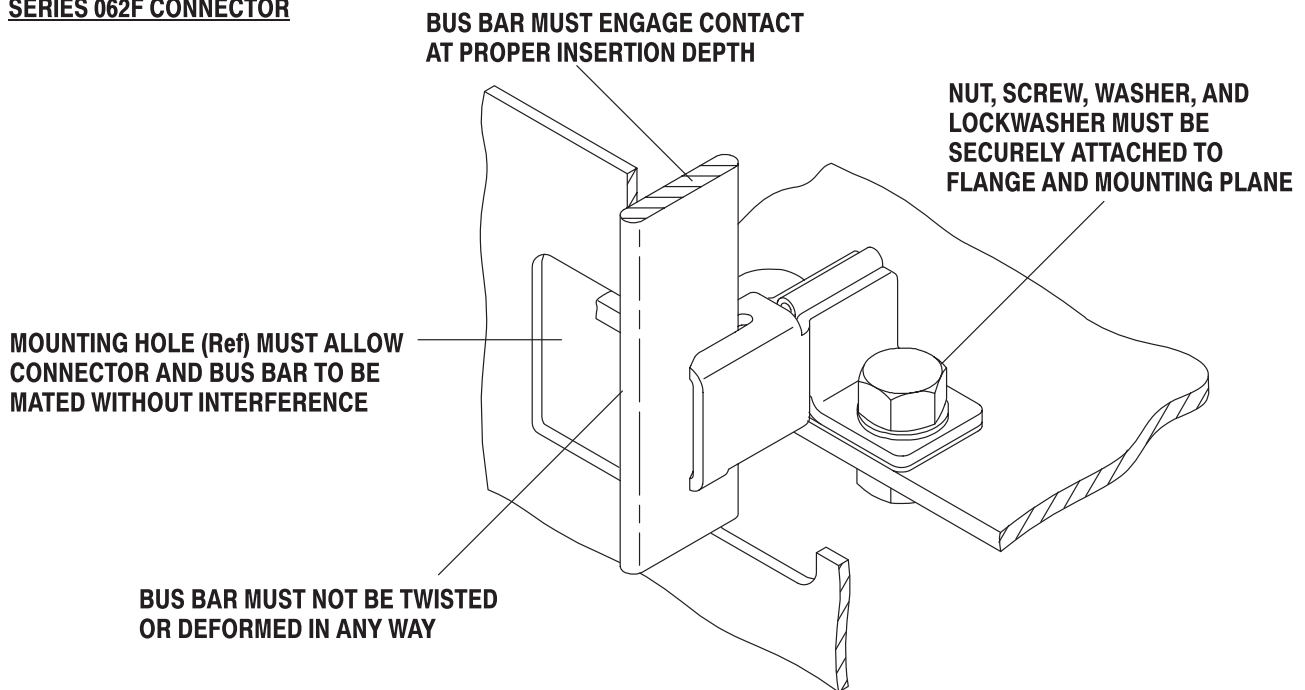

FIGURE 8. VISUAL AID