

**NOTE** All numerical values are in metric units [with U.S. customary units in brackets]. Dimensions are in millimeters [and inches]. Unless otherwise specified, dimensions have a tolerance of  $\pm 0.13$  [ $\pm .005$ ] and angles have a tolerance of  $\pm 2^\circ$ . Figures and illustrations are for identification only and are not drawn to scale.

**1. INTRODUCTION**

This specification covers the requirements for application of AMP\* FASTON Series 187, 205, and 250 stud mount terminals onto printed circuit (pc) boards. These terminals are designed to accept Series 187, 205, and 250 FASTON and Ultra-Fast receptacles. The series number designator corresponds to the width of the terminal tab (in hundredths of inch). The terminals are available with tabs in 4.75 [.187], 5.21 [.205], and 6.35 [.250] widths and height range of 1.73 through 11.99 [.068 through .472]. The tab has a tapered lead-in to ease insertion of mating receptacles. The dimple or retention hole helps retain the mating receptacle and the receptacle stop prevents over-insertion of the mating receptacle. The stud hole accepts commercially available hardware for mounting the terminal onto the pc board.

The terminals are available in right-angle, angled, and vertical configurations with single, double, or triple tabs. The terminals are available in loose piece form for hand tooling application and strip form for automatic machine application.

When corresponding with AMP personnel, use the terminology provided in this specification to facilitate your inquiries for information. Basic terms and features of these connectors are provided in Figure 1.

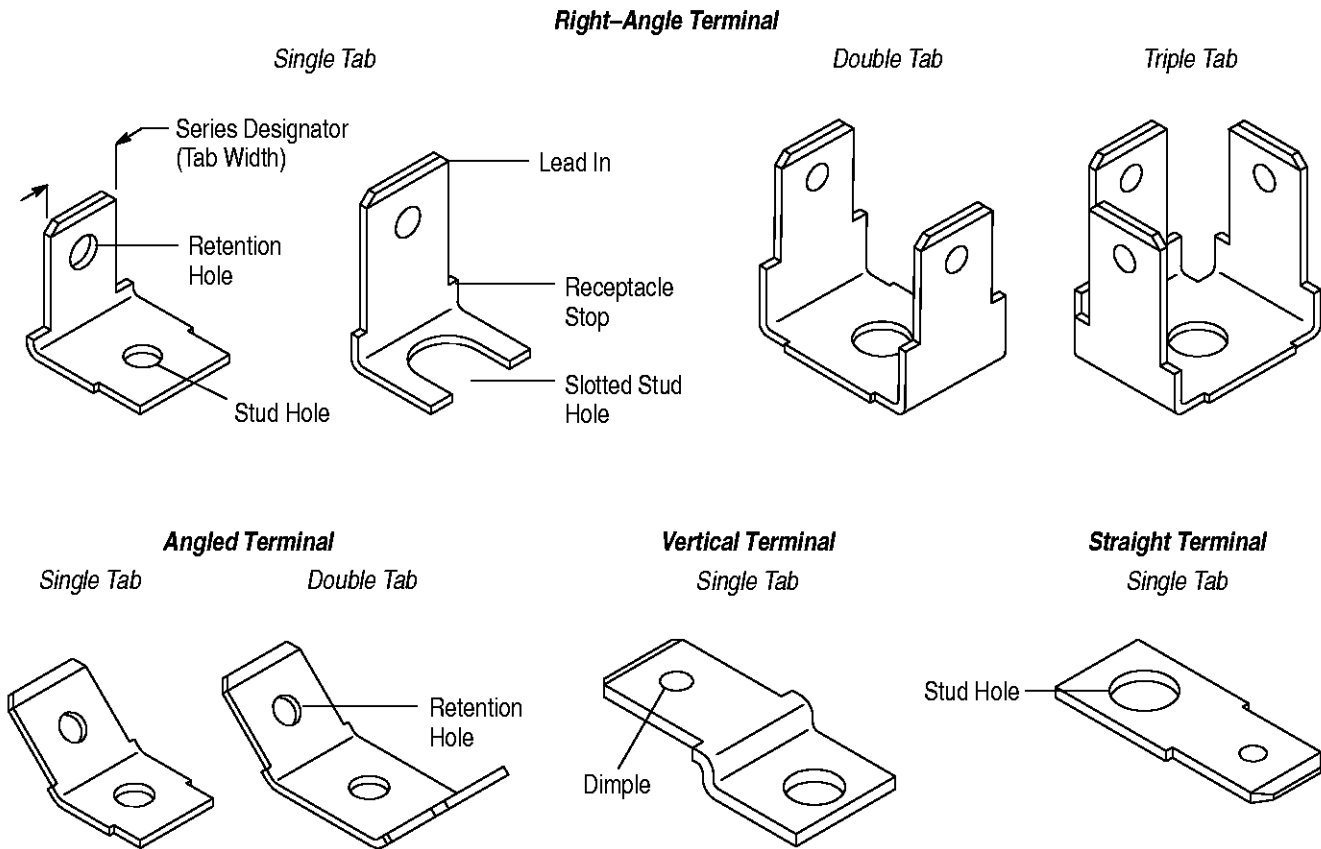

Figure 1

## 2. REFERENCE MATERIAL

### 2.1. Revision Summary

Per EC 0990-0699-99:

- Initial release of application specification

### 2.2. Customer Assistance

Product Part Number 63946 and Product Code 1101 are representative of AMP FASTON stud mount terminals. Use of these numbers will identify the product line and expedite your inquiries through an AMP service network established to help you obtain product and tooling information. Such information can be obtained through a local AMP Representative (Field Service Engineer, Field Applications Engineer, etc.) or, after purchase, by calling the Product Information Center at the number at the bottom of page 1.

### 2.3. Drawings

AMP Customer Drawings for product part numbers are available from the service network. If there is a conflict between the information contained in the Customer Drawings and this specification or with any other technical documentation supplied by AMP, call the Product Information Center at the number at the bottom of page 1.

## 3. REQUIREMENTS

### 3.1. Material

The terminals are made of brass with no plating or plated with nickel or tin. The terminals can withstand a maximum temperature of 110°C [230°F]. The stock thickness for Series 187 terminals is 0.51 [.020], and for Series 205 and 250 terminals is 0.81 [.032].

### 3.2. Chemical Exposure

Do not store terminals near any chemical listed below as they may cause stress corrosion cracking in the terminals.

Alkalies	Ammonia	Citrates	Phosphates	Citrates	Sulfur Compounds
Amines	Carbonates	Nitrites	Sulfur Nitrites	Nitrites	Tartrates

### 3.3. Preparation

Cutoff tabs are the remaining portion of the carrier strip after the terminal is cut from the strip. The following dimensional requirements will ensure proper application for these terminals.

1. The cutoff tab must not exceed the dimension shown in Figure 2.
2. The burr resulting from the cutoff tab shearing must not exceed the dimension shown in Figure 2.

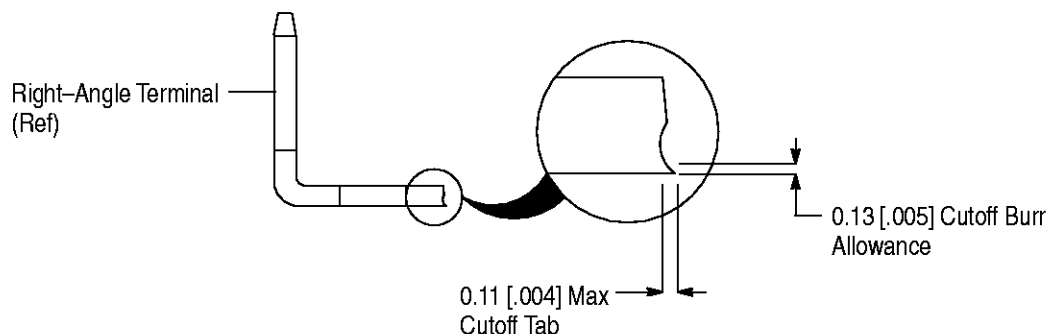

Figure 2

### 3.4. PC Board

#### A. Material and Thickness

The pc board material must be non-metallic. The pc board thickness shall be any thickness meeting your application needs.

**B. Hole Dimensions**

The mounting holes must be drilled through to specific dimensions to ensure proper placement of the terminal on the pc board. The drilled hole size is dependent on the terminal series and configuration as listed in Figure 3.

SERIES	TAB	CONFIGURATION	MOUNTING HOLE SIZE (Diameter)
187	Single	Right Angle	2.77 [.109] or 3.68 [.145]
		Angled	3.30 [.130], 3.68 [.145], or 4.34 [.171]
	Double	Right Angle	3.30 [.130] or 5.00 [.197]
205	Single	Right Angle	3.30 [.130] or 3.68 [.145]
250	Single	Vertical	3.30 [.130]
		Right Angle	2.46 [.097], 3.30 [.130], 4.34 [.171], or 5.16 [.203]
		Angled	3.60 [.105], 3.30 [.130], 4.34 [.171], 5.00 [.197], or 5.60 [.203]
	Double	Right Angle	2.46 [.097], 3.30 [.130], or 4.34 [.171]
		Angled	3.30 [.130] or 4.34 [.171]
Triple	Right Angle	3.30 [.130]	

Figure 3

**3.5. Terminal Spacing**

Care must be taken to avoid interference between adjacent terminals and/or other components. There is no required spacing between terminals, however spacing may be dependent on variable hardware used and the clearance required for mating receptacles.

**3.6. Mounting Hardware**

The terminals can be mounted onto the pc board through the stud hole using a bolt and nut, rivet, screw, or other suitable commercially available fastening device suitable to the terminal material and will not interfere with terminal mating. Mounting hardware is customer supplied.

**3.7. Straightness**

The terminal must be perpendicular to the pc board within the tolerance provided in Figure 10.

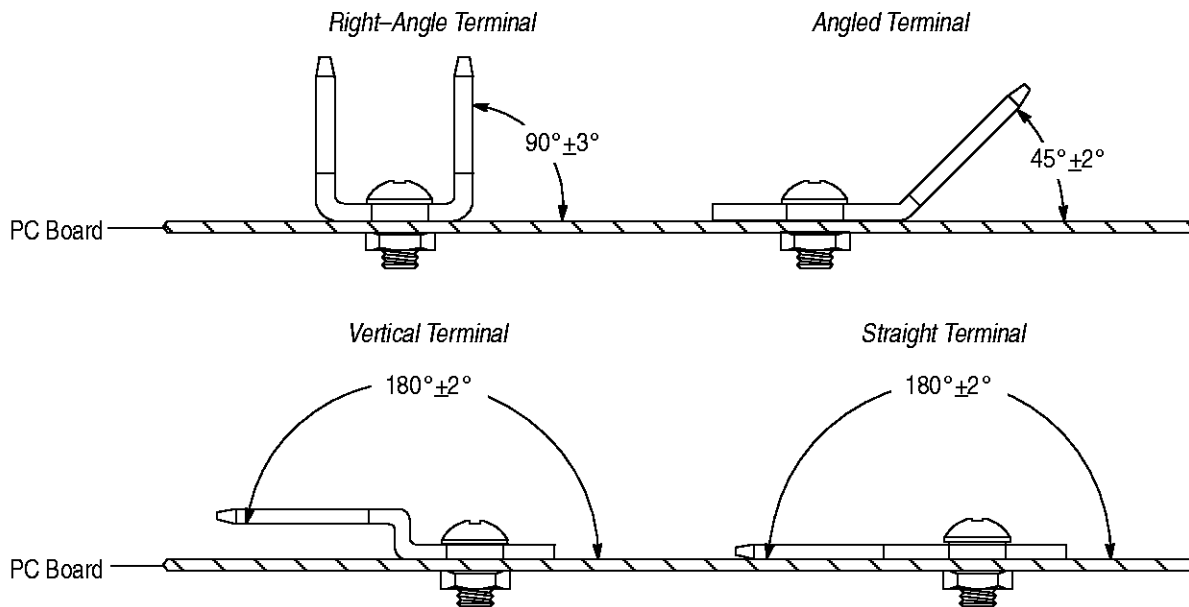

Figure 4

### 3.8. Checking Installed Terminal

Installed terminals must conform to the following requirements:

1. The terminal must be seated on the pc board to the dimension shown in Figure 5.
2. The terminal must be firmly secured to the pc board with appropriate mounting hardware.
3. The terminal must have no deformation that will hinder mating or unmating, or otherwise affect performance of the terminal or other components.
4. The terminal must not be scraped, gouged, or heavily marked; light tooling marks are permissible.

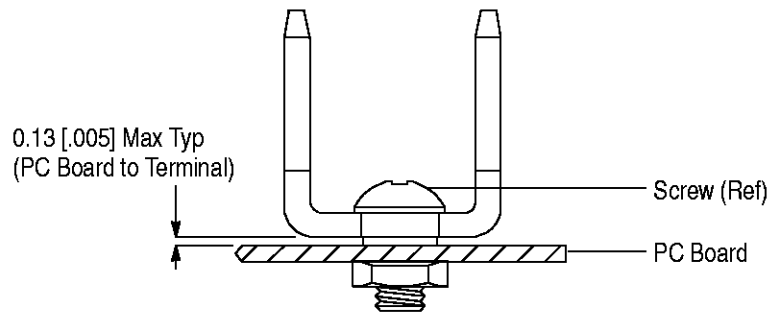

Figure 5

### 3.9. Repair

Damaged terminals must be removed and replaced with a new one. Care must be used to prevent damage to the pc board or surrounding components.

## 4. QUALIFICATION

FASTON Series 187, 205, and 250 stud mount terminals are listed by the Component Program of Underwriters Laboratories Inc. (UL) under File E28476 and E13288, and certified to Canadian Standards Association (CSA) under File LR 7189A-509.

## 5. TOOLING

No tooling is available through AMP for cutting the strip form terminals from the carrier strip.

No special tooling is required for manual placement of the terminals onto the pc board.

**6. VISUAL AID**

The illustration below shows a typical application of AMP FASTON Series 187, 205, and 250 stud mount terminals. This illustration should be used by production personnel to ensure a correctly applied product. Applications which DO NOT appear correct should be inspected using the information in the preceding pages of this specification and in the instructional material shipped with the product or tooling.

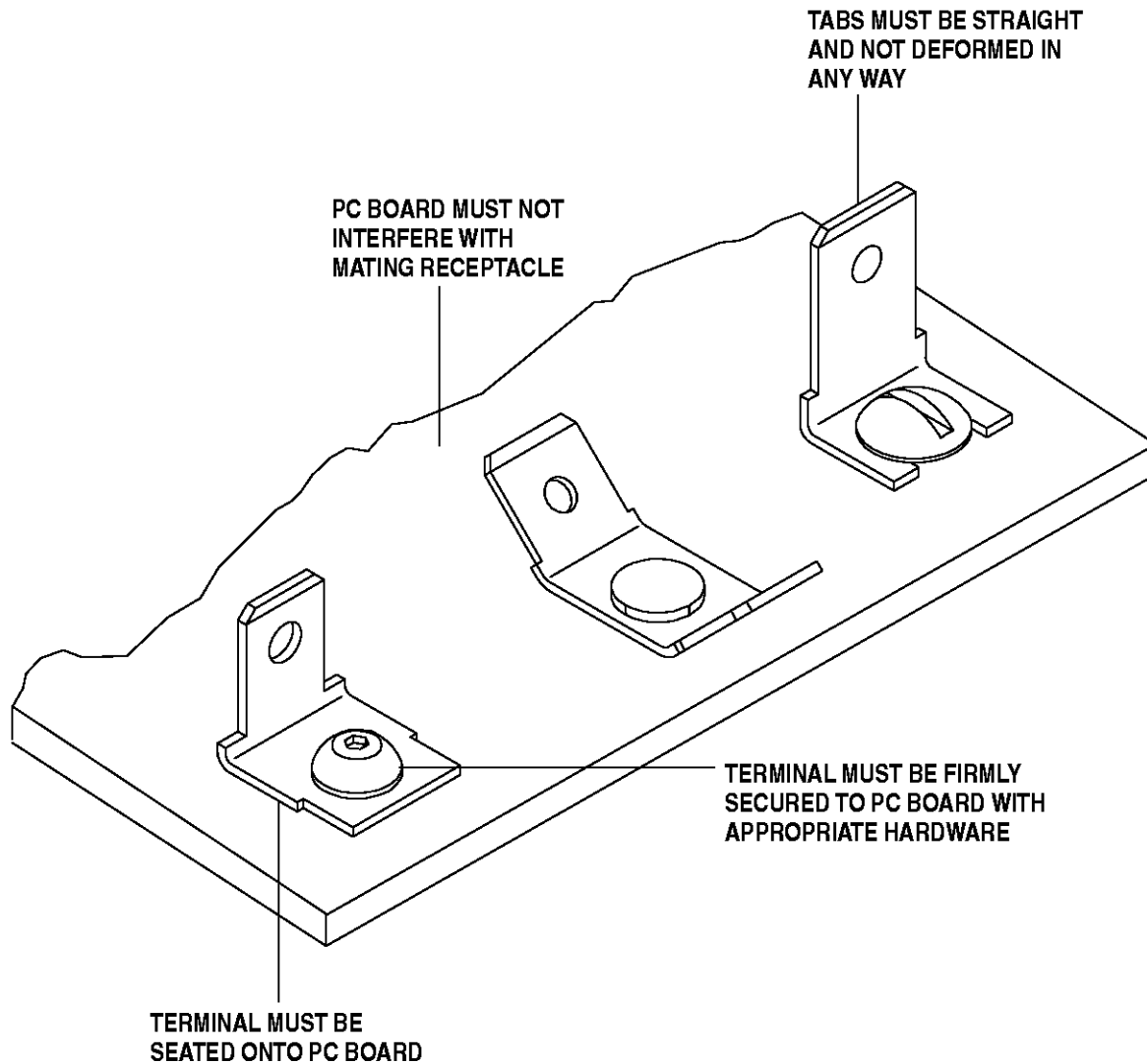
**FIGURE 6. VISUAL AID**