

NOTE

All numerical values are in metric units [with U.S. customary units in brackets]. Dimensions are in millimeters [and inches]. Unless otherwise specified, dimensions have a tolerance of ± 0.13 [.005] and angles have a tolerance of $\pm 2^\circ$. Figures and illustrations are for identification only and are not drawn to scale.

1. INTRODUCTION

This specification covers the requirements for application of the AMP* AMP-LATCH Ultra Novo Receptacle 40-Position Connector for ribbon cable with 80 conductors on 0.64 [.025] centerlines. These receptacle connectors are available with center and military polarization or military polarization alone.

The contacts housed in these receptacles are of the insulation displacement connection (IDC) type. They accept mating headers or other pin connectors having 0.64 [.025]-square pins or 0.64 [.025]-diameter round pins 6.1 [.240] nominal length. Intermateability limitations and available polarization features are detailed in Paragraph 3.4.

When corresponding with Tyco personnel, use the terminology provided on this specification to help facilitate your inquiry for information. Basic terms and features of receptacles are provided in Figure 1.

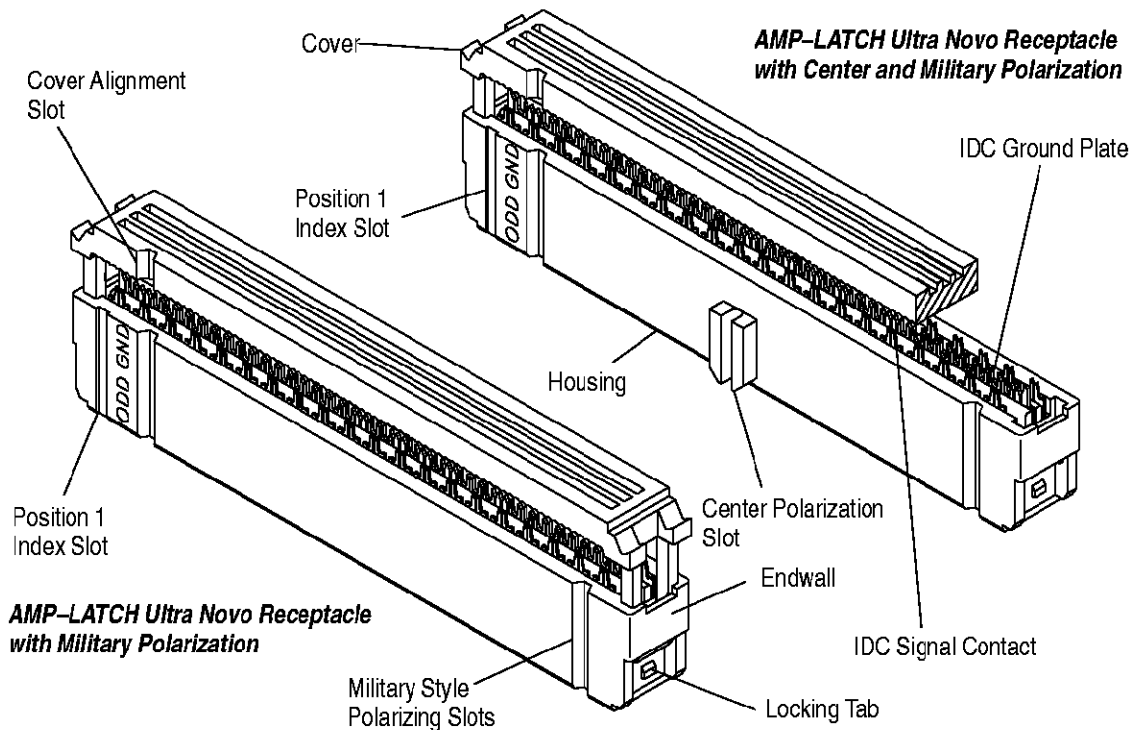

Figure 1

2. REFERENCE MATERIAL

2.1. Revision Summary

This paragraph is reserved for a revision summary of the most recent additions and changes made to this specification which include the following:

Per EC 0990-1405-99

- Updated document to corporate requirements
- Changed locking tab configuration in Figures 1, 4, 5, 6, 7, 8, and 10
- Made text changes in Paragraphs 3.2, 3.4, and 3.6.C
- Made text changes in Figures 2, 5, and 8

2.2. Customer Assistance

Reference Part Number 120605 and Product Code A252 are representative numbers of AMP-LATCH Ultra Novo Receptacle Connectors for 0.64 [.025] Ribbon Cable. Use of these numbers will identify the product line and expedite your inquiries through a service network established to help you obtain product information. Such information can be obtained through a local Tyco Representative (Field Sales Engineer, Field Applications Engineer, etc) or, after purchase, by calling the Tooling Assistance Center or the AMP FAX/Product Information Center number at the bottom of page 1.

2.3. Drawings

Customer Drawings for each connector are available from the service network. The information contained in Customer Drawings takes priority if there is a conflict with this specification or with any technical documentation supplied by Tyco Electronics.

2.4. Specifications

Product Specification 108-1740 and 108-1740-1 provide product performance requirements and test information.

2.5. Instructional Material

The following list includes available instruction sheets (408-series) that provide assembly procedures for product, operation, maintenance and repair of tooling; and customer manuals (409-series) that provide setup, operation, and maintenance of machines.

<u>Document Number</u>	<u>Document Title</u>
408-4201	Base Assembly Universal Arbor Tool 768338-4
408-4445	Connector-Specific Kit 904379-1 for Ultra Novo 40-Position Receptacle Connectors
408-6732	Pneumatic Auto-Cycle Unit
408-7763	Pneumatic Applicator Frame Assembly
408-7777	Manual Arbor Frame Assembly
409-5873	R-CAM 4 Cable Terminating Machine

3. REQUIREMENTS

3.1. Storage

A. Ultraviolet Light

Prolonged exposure to ultraviolet light may deteriorate the chemical composition used in the receptacle connector material.

B. Shelf Life

The connectors should remain in the shipping containers until ready for use to prevent deformation to the connectors. The connectors should be used on a first in, first out basis to avoid storage contamination.

C. Chemical Exposure

Do not store contacts near any chemicals listed below as they may cause stress corrosion cracking in the contacts.

Alkalies	Ammonia	Citrates	Phosphates	Citrates	Sulfur Compounds
Amines	Carbonates	Nitrites	Sulfides	Nitrites	Tartrates

NOTE

Where the above environmental conditions exist, phosphor-bronze contacts are recommended instead of brass if available.

3.2. Special Characteristics

The AMP-LATCH Ultra Novo Receptacle Connectors are available in 3 colors. Most have a molded keying plug in position 20 to comply with SFF-8049. The blue connector is grounded in position number 34 and is used in a systems pc board; the gray connector has an open position number 28 and is used as a device (1) slave; and the black connector is for device (0) primary. Also, the cable connecting the blue and gray connectors must have position 68 punched out.

NOTE

The gray receptacle connectors do not have a contact at position 28.

3.3. Cable Selection and Preparation

The IDC contacts in AMP-LATCH receptacles are designed to accept PVC-insulated cable wires with 30 AWG copper solid conductors or 7/38 stranded tinned copper conductors. Insulation materials other than standard PVC must be submitted to Tyco Engineering for evaluation before use. An initial cut needs to be made using a guillotine-type cutting tool. See Figure 2. Contact your Tyco representative for current tool recommendations for cutting and notching of cables.

NOTE A notching procedure is required when a circuit between two connectors is to be disconnected. In this case, the notching size and location have to be carefully determined. Contact the Product Information Center number at the bottom of page 1 for specific information on this process.

CAUTION Care must be taken when aligning cable prior to termination to maintain perpendicularity between the length of the cable and the length of the connector.

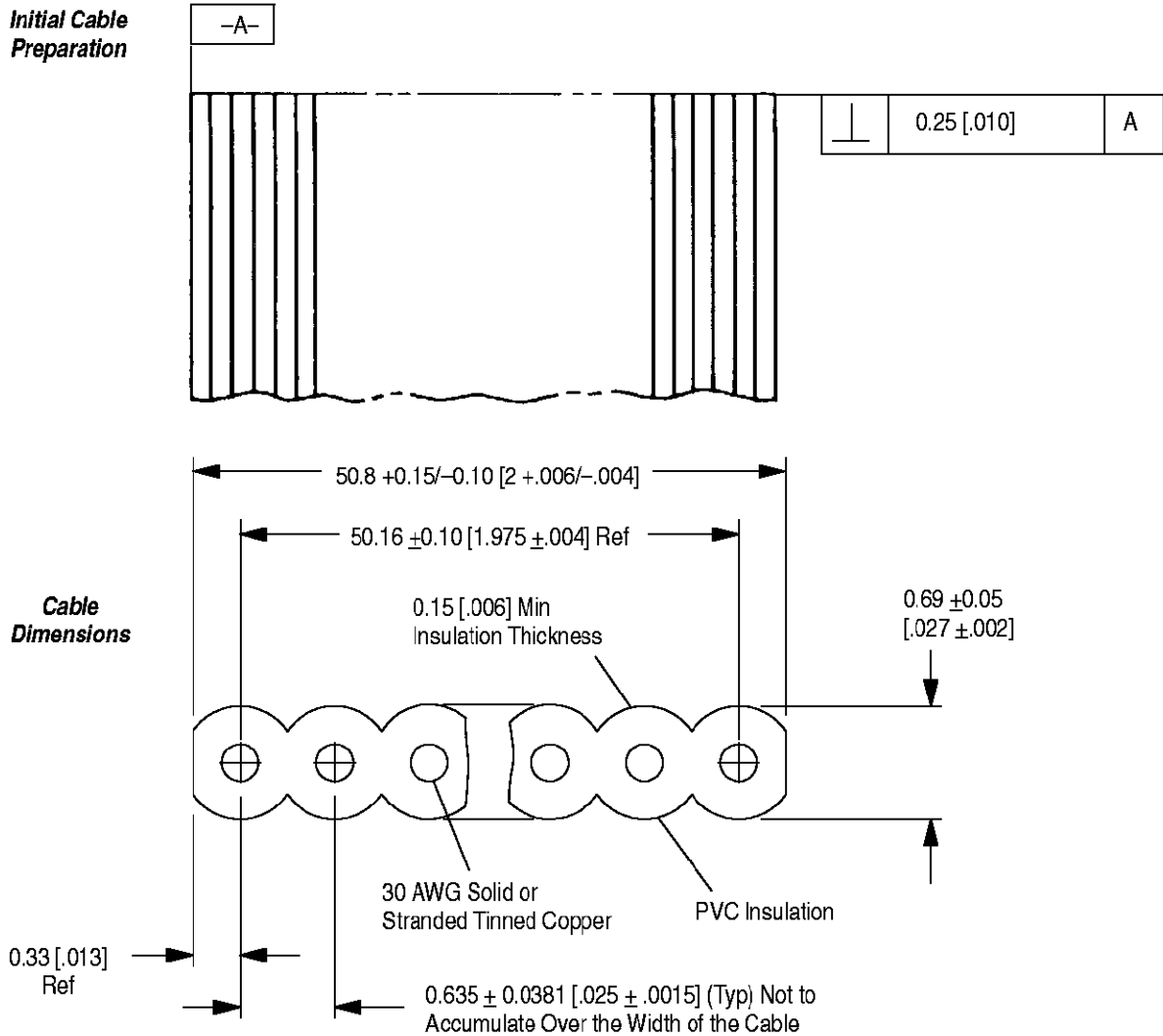

Figure 2

3.4. Product Selection

Specific acceptable pin length range limitations are shown below:

Receptacle Type	Pin Length Range Accepted
Ultra Novo	4.44 to 6.22 [.175 to .245]

Figure 3 shows the relationships between available receptacles and the connectors that will mate with them.

MATING CONNECTOR TYPES	RECEPTACLE TYPE AND POLARIZATION OPTIONS (ULTRA NOVO)	
	DUAL SLOT (MILITARY)	DUAL SLOT AND CENTER SLOT
Pin Connector with or without Mounting Ears	X	X
Pin Connector with or without Mounting Ears and with Detent Windows	X	X
Bulkhead Pin Connector	X	—
Universal Ejection Style Pin Header	X	X
Low-Profile Pin Header	X	X
High Temperature Universal Ejection Style Pin Header	X	X
Universal Ejection Style Pin-less Header	X	X
Stacked Headers	X	X
AMPMODU* Headers●	X	—

●Only headers that have a 3.81 [.150] end dimension will mate.

Figure 3

NOTE The assembled receptacle connectors include a pre-positioned cover for end terminations or daisy chain applications.

Polarization has been designed into the housing and covers. Receptacles with dual slots (military) only can be used in all header and plug connectors. Those with a combination of dual slots (military) and center slot polarization can only be used with header or plug connectors that have a center polarization slot. See Figure 4.

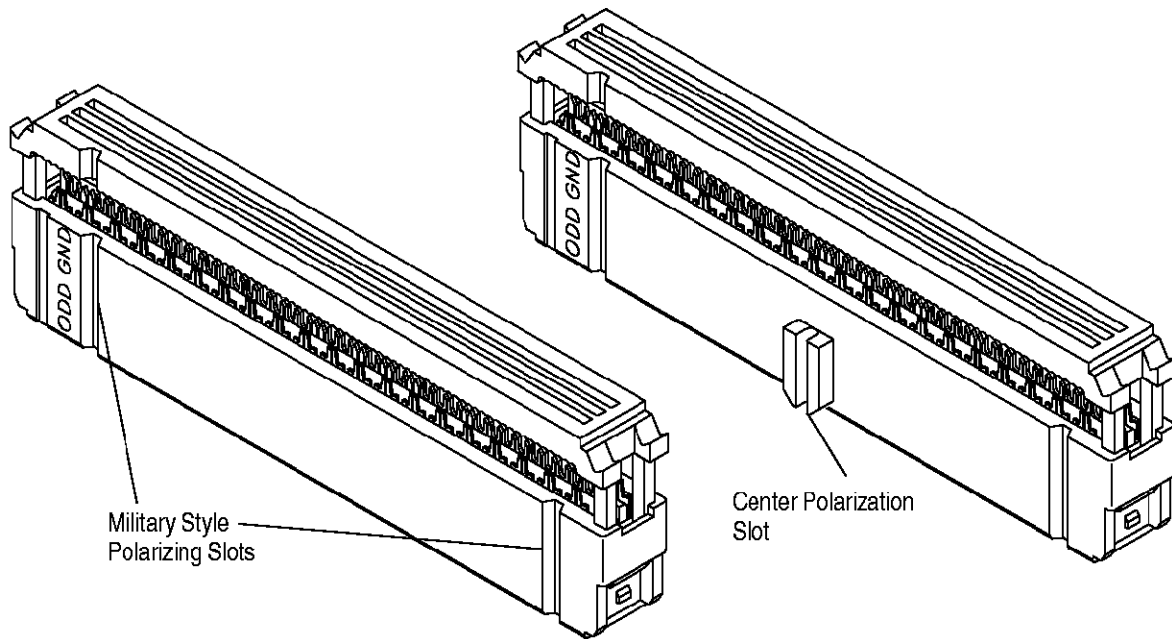

Figure 4

3.5. Terminated Receptacle Requirements

Prepared cable shall be terminated according to the procedures given in the applicable tooling instructions. See Section 5, TOOLING, for details on tooling options and instructional materials. Figure 5 shows criteria for acceptable terminations.

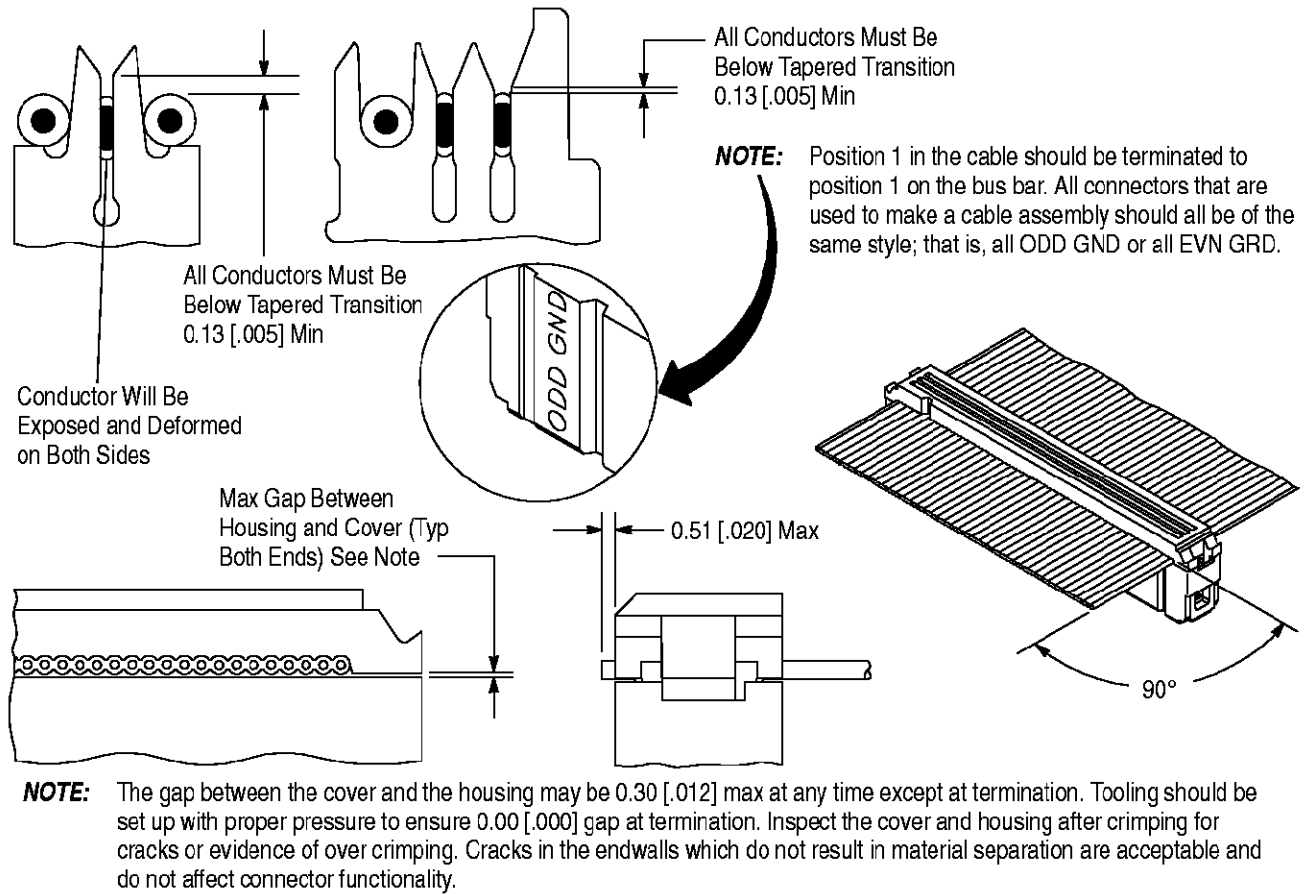

Figure 5

CAUTION When removing the connector from its' mate, grasp the ends of the connector and pull off. Do NOT apply force to the cable itself or irreparable damage may result. In applications where connector removal is likely, it is strongly suggested that a strain relief and flexible pull tab, flexible pull-loop, or rectangular pull tab as described in Figure 8 be added to the connector assembly.

3.6. Accessories

A. Strain Relief

Strain relief may be added to any application. See Figure 6.

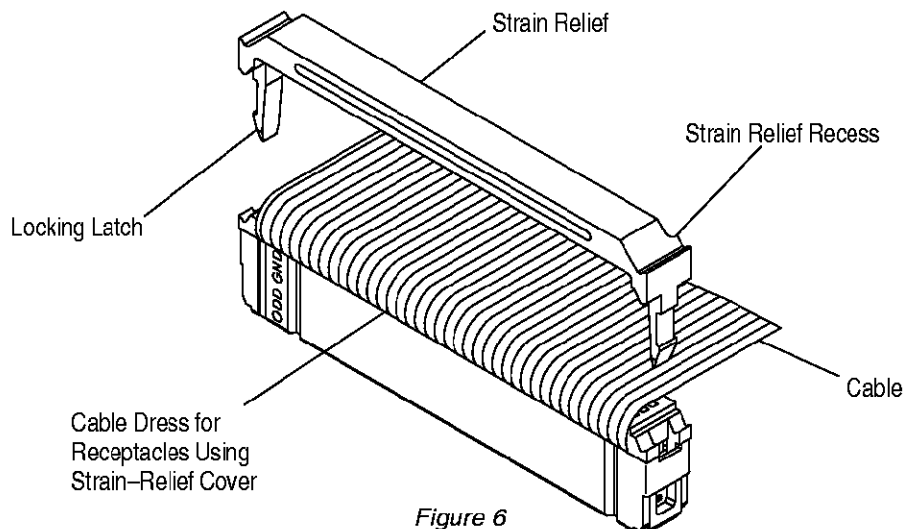

Figure 6

B. Keying Plugs

Keying plugs are designed to be hand inserted directly into the contact cavities. Corresponding pins must be removed from the mating connector. See Figure 7.

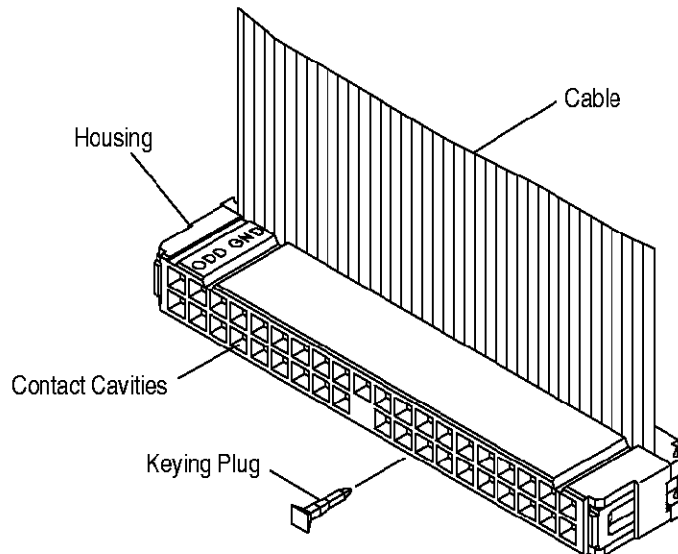

Figure 7

C. Pull Tabs, Pull-loop

Flexible pull-tabs and pull-loops may be permanently assembled to the receptacle. The pull-loop is installed between the strain relief and the cover in strain-relieved applications. Unattached, insertion type of pull-tabs are also available for receptacles not employing strain relief. See Figure 8.

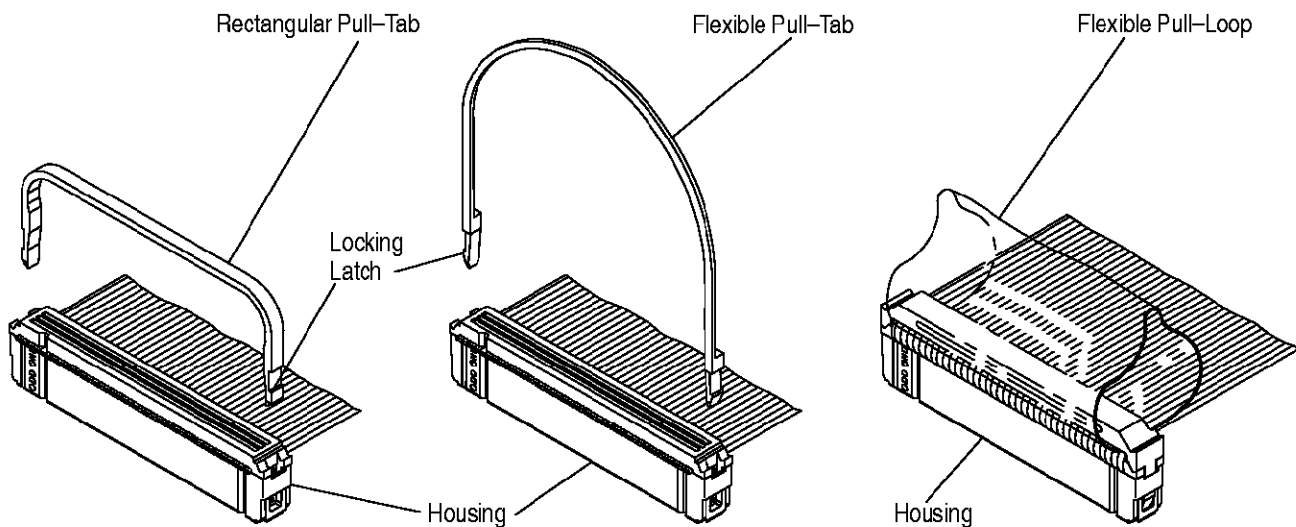

Figure 8

3.7. Testing

Completed cable assemblies should be tested for continuity using a CIRRIS Tester or similar equipment. Refer to the documentation furnished with the tester for specific testing instructions and requirements.

The automatic cable assembly machine described in Section 5 contains test equipment, and should be operated according to the documentation supplied with it.

4. QUALIFICATIONS

AMP-LATCH Ultra Novo Receptacle Connectors are listed by Underwriters Laboratories Inc. (UL) under File No. E28476, and certified to the Canadian Standards Association (CSA) under File No. LR7189A-615.

5. TOOLING

This section provides a selection of tools for various application requirements. Modified designs and additional tooling concepts may be available to meet other application requirements. For additional information, contact one of the service groups at the bottom of page 1.

There are manually operated and pneumatically operated (auto-cycle and foot pedal actuated) arbor frame assemblies designed for bench mounted operation. They accept standardized upper/lower tooling assemblies that have been designed for the AMP-LATCH Connector-Specific Kit. Instruction sheets covering tool setup and operation are packaged with the tooling. See Figure 9.

There is one high production automatic machine designed to make cable assemblies using standard planar ribbon cable described in Figure 2. It is the R-CAM 4 which terminates up to 10 connectors. The machine can accommodate variations of the AMP-LATCH Ribbon Cable Connectors with 0.64 [.025] centerline cable. A customer manual for setup and operation is supplied. The machine will test the cable assemblies for continuity and short circuits as they are being processed. See Figure 9.

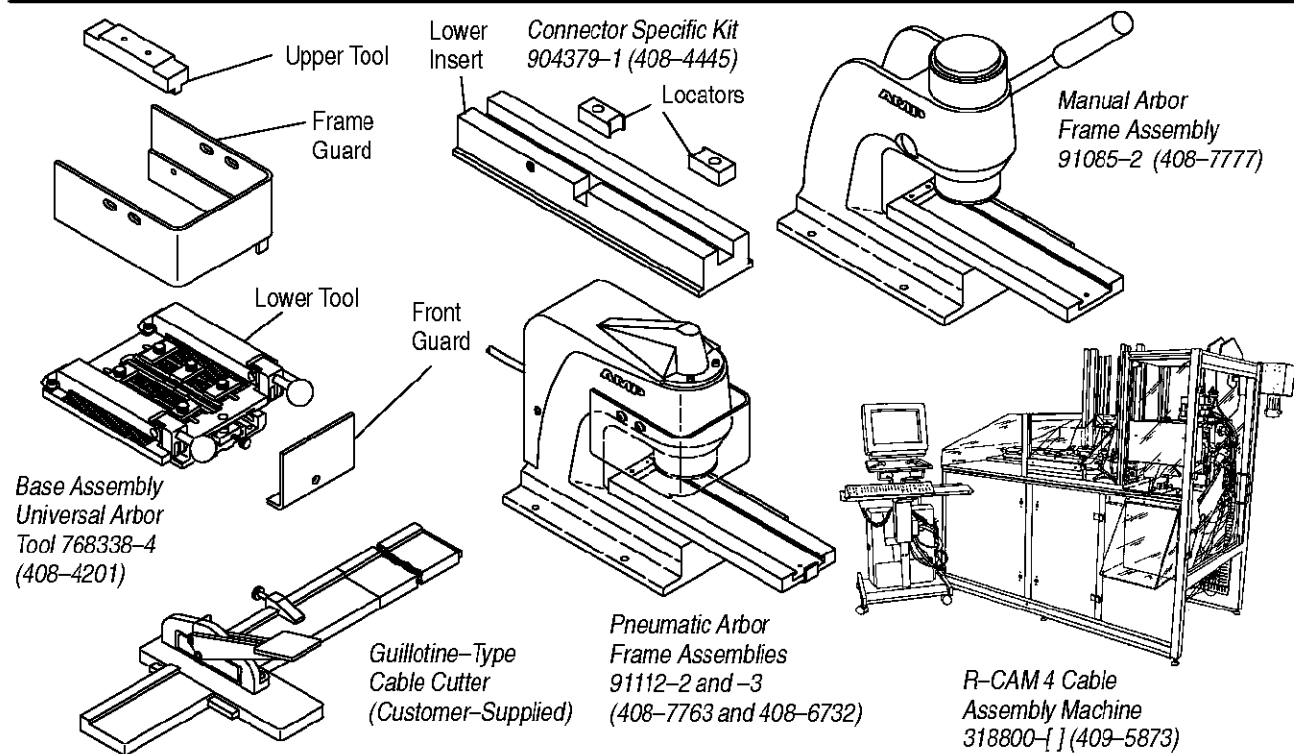

CONNECTOR TYPE	CONNECTOR SPECIFIC KIT (DOCUMENT)	BASE ASSEMBLY UNIVERSAL ARBOR TOOL (DOCUMENT)	ARBOR FRAME ASSEMBLY (DOCUMENT)	TOOLING PACKAGE ASSEMBLY	POWER UNIT (DOCUMENT)
AMP-LATCH Ultra Novo Receptacle Connectors	904379-1 (408-4445)	768338-4 (408-4201)	91085-2 (408-7777), 91112-2 (408-7763), 91112-3 (408-6732)	—	—
	—	—	—	1213426-[]	318800-[] (409-5873)

Figure 9

6. VISUAL AID

Figure 10 shows a typical application of AMP-LATCH Ultra Novo Receptacle Connectors for 0.64 [.025] Ribbon Cable. This illustration should be used by production personnel to ensure a correctly applied product. Applications which DO NOT appear correct should be inspected using the information in the preceding pages of this specification and in the instructional material shipped with the product or tooling.

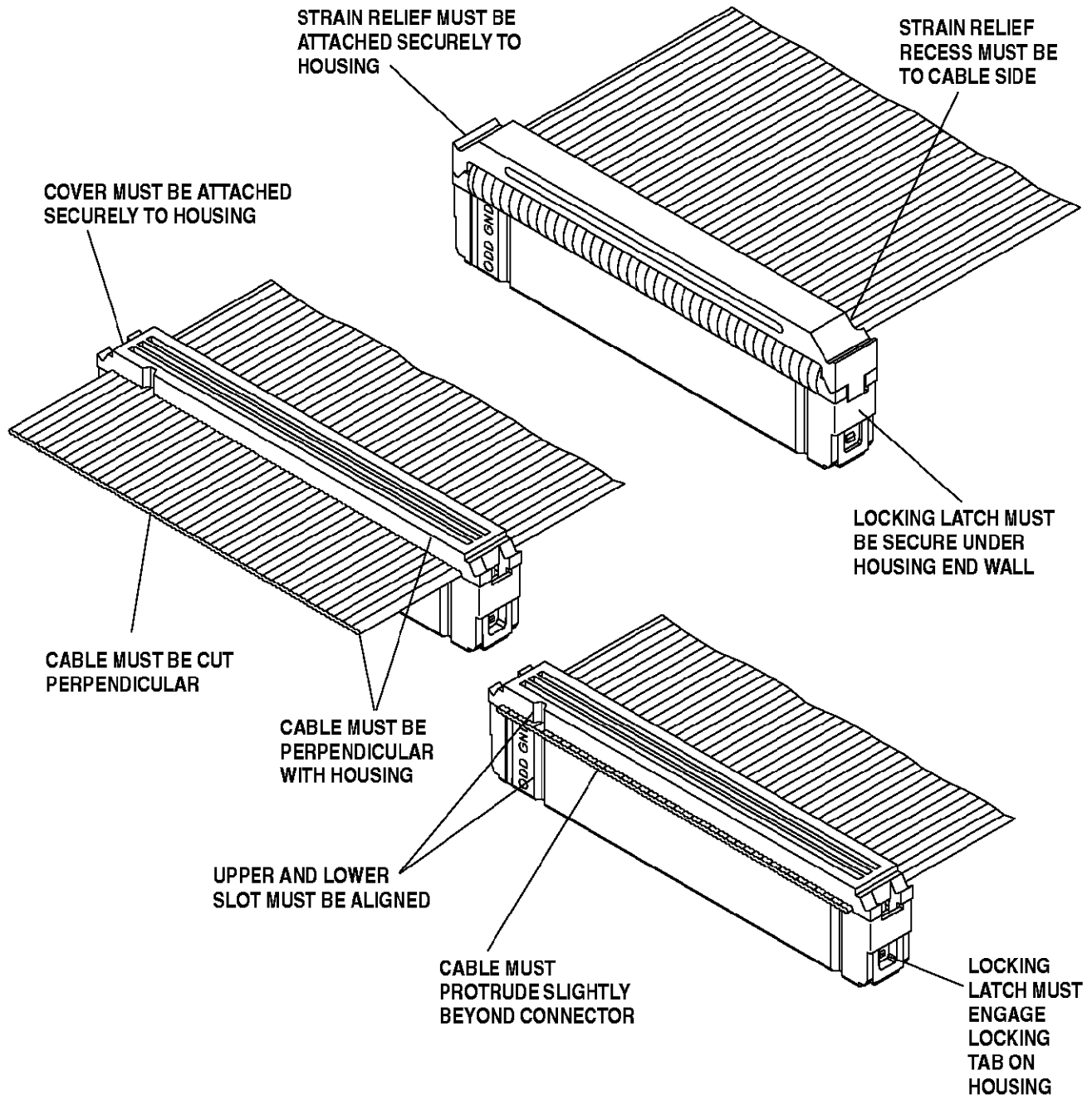
**FIGURE 10. VISUAL AID**