

THIS DRAWING IS UNPUBLISHED. RELEASED FOR PUBLICATION .19 .
 © COPYRIGHT 19 BY AMP INCORPORATED. ALL INTERNATIONAL RIGHTS RESERVED.

LOC	DIST	ZONE	LTR	DESCRIPTION	DATE	APPD
G	14		A	REVISED PER 0720-0230-93	2/28/93	DAP

METRIC
 DIMENSIONS LISTED IN mm [INCHES]

AMP WIRE RANGE	UL E13288 Listed
12-10 AWG STRANDED	12-10 AWG STRANDED
LR7189 Certified	MILITARY P/N AND CLASS
NOT CERTIFIED	NOT APPLICABLE

⚠ STAMP AMP 12-10* APPROX AS SHOWN

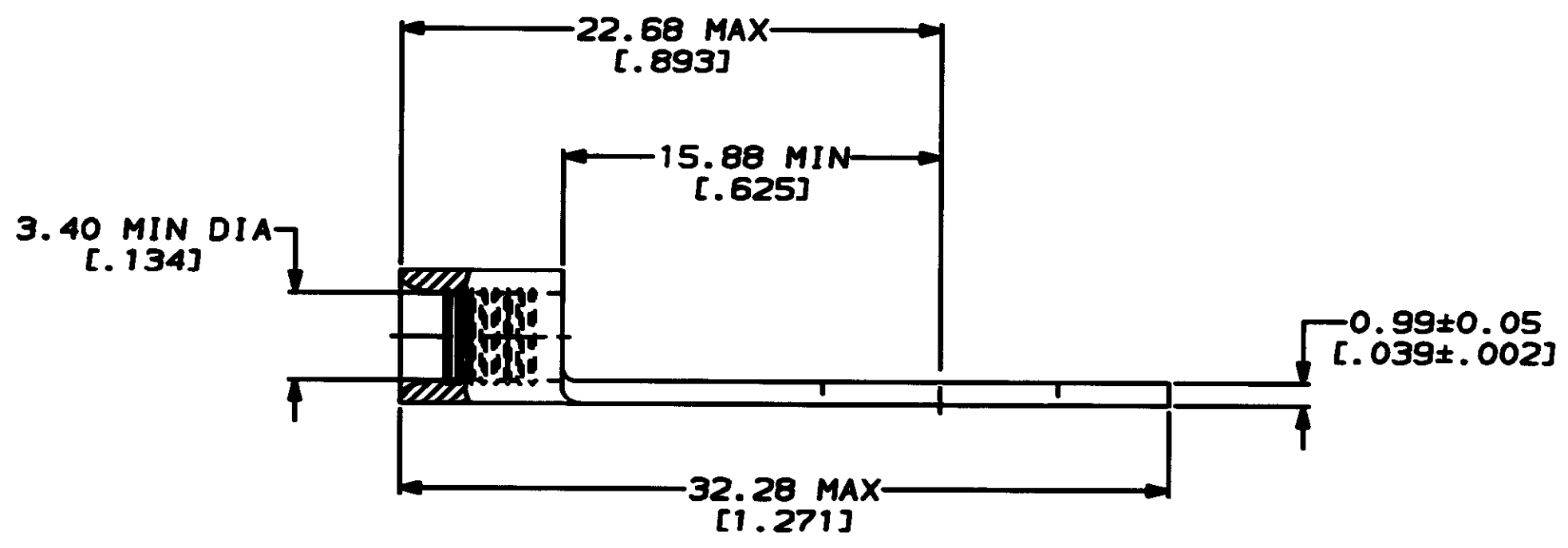
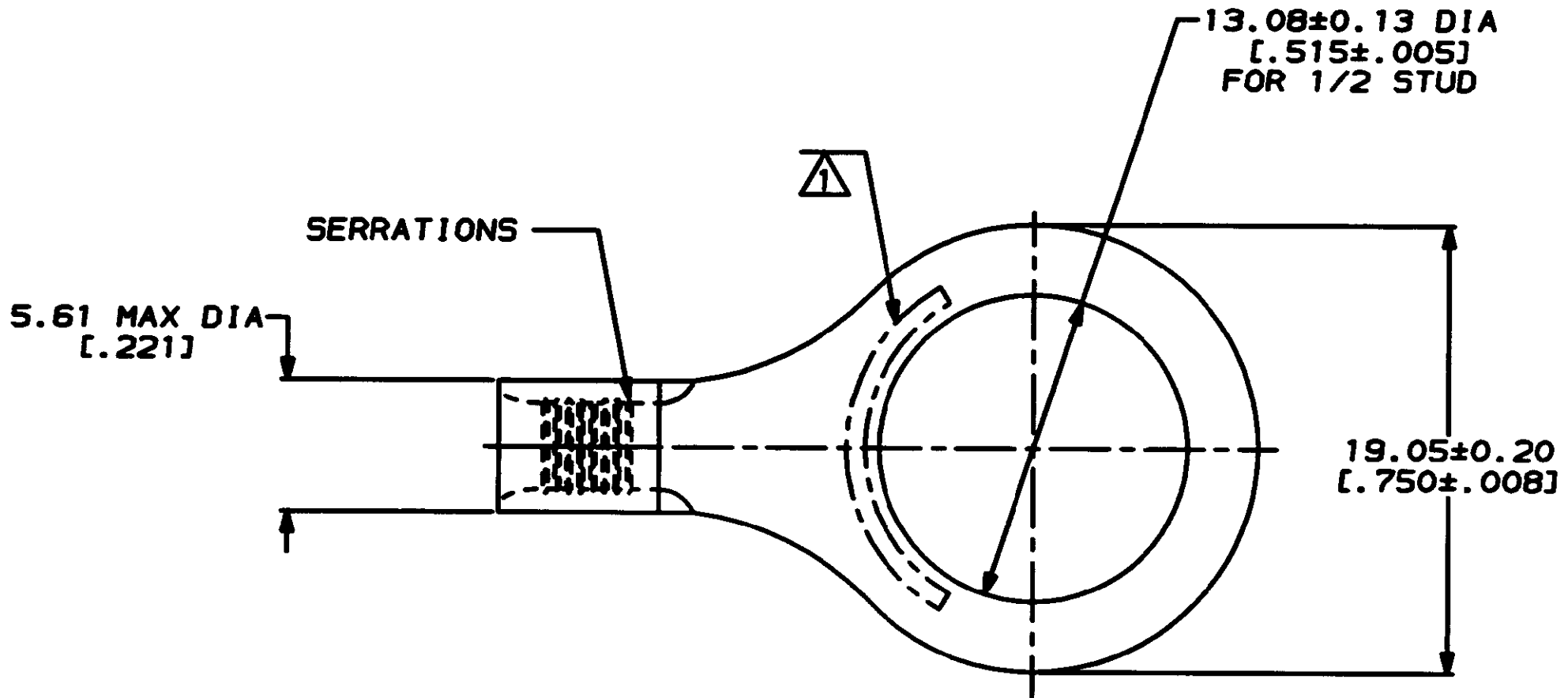

34834
 PART NO

AMP INCORPORATED
CUSTOMER SERVICE SYSTEMS

MAX RECOMMENDED OPERATING TEMPERATURE:
 170°C MAX

DO NOT SCALE PRINT. UNLESS SPECIFIED DIMENSIONS IN mm [INCHES] TOLERANCES ON:
 2 PLC DEC ± -
 3 PLC DEC ± -
 ANGLES ± -

DR 2-8-93
 TA BRINKMAN
 CHK 2-8-93
 DA PATTERSON
 APPD 2-8-93
 DE MILLER
 APPD 2-8-93
 JL HECKLEY
 PRODUCT SPEC -
 APPLICATION SPEC -
 WEIGHT -

AMP AMP Incorporated
 Harrisburg, PA 17105-3508

FOR ADDITIONAL PRODUCT INFORMATION OR COPIES OF DRAWINGS AND TECHNICAL DOCUMENTS
 FOR APPLICATION TOOLING INFORMATION
 FOR ORDER ENTRY

PRODUCT INFORMATION CENTER
 1-800-522-6752
 TOOLING ASSISTANCE CENTER
 1-800-722-1111
 1-800-526-5142

VOLTAGE RATING:
 NOT APPLICABLE
 WIRE CROSS SECTIONAL AREA RANGE:
 2.62-6.64mm² [5,180-13,100] CIR MILS STRANDED
 THIS DRAWING IS A CONTROLLED DOCUMENT FOR AMP INCORPORATED. IT IS SUBJECT TO CHANGE AND THE CONTROLLING ORGANIZATION SHOULD BE CONTACTED FOR THE LATEST REVISION.

MATERIAL
 COPPER PER ASTM B-152 ANNEALED
 FINISH
 TIN PLATE 0.00254 [0.000100] MIN THK PER MIL-T-10727

NAME
TERMINAL, RING TONGUE, BUDGET
 SIZE CAGE CODE DRAWING NO
 C 00779 C-34834
 SCALE 4:1 SHEET 1 OF 1