

LOC	DIST	REV	ZONE	LTR	DESCRIPTION	DATE	APPD
G	14	A			REVISED PER 0720-0230-93	2/28/94	gdp

METRIOS
 DIMENSIONS LISTED IN MM [INCHES]

AMP WIRE RANGE	UL E13288 Listed
12-10 AWG STRANDED	12-10 AWG STRANDED
LR7189 Certified	MILITARY P/N AND CLASS
NOT CERTIFIED	NOT APPLICABLE

△ STAMP AMP 12-10* APPROX AS SHOWN

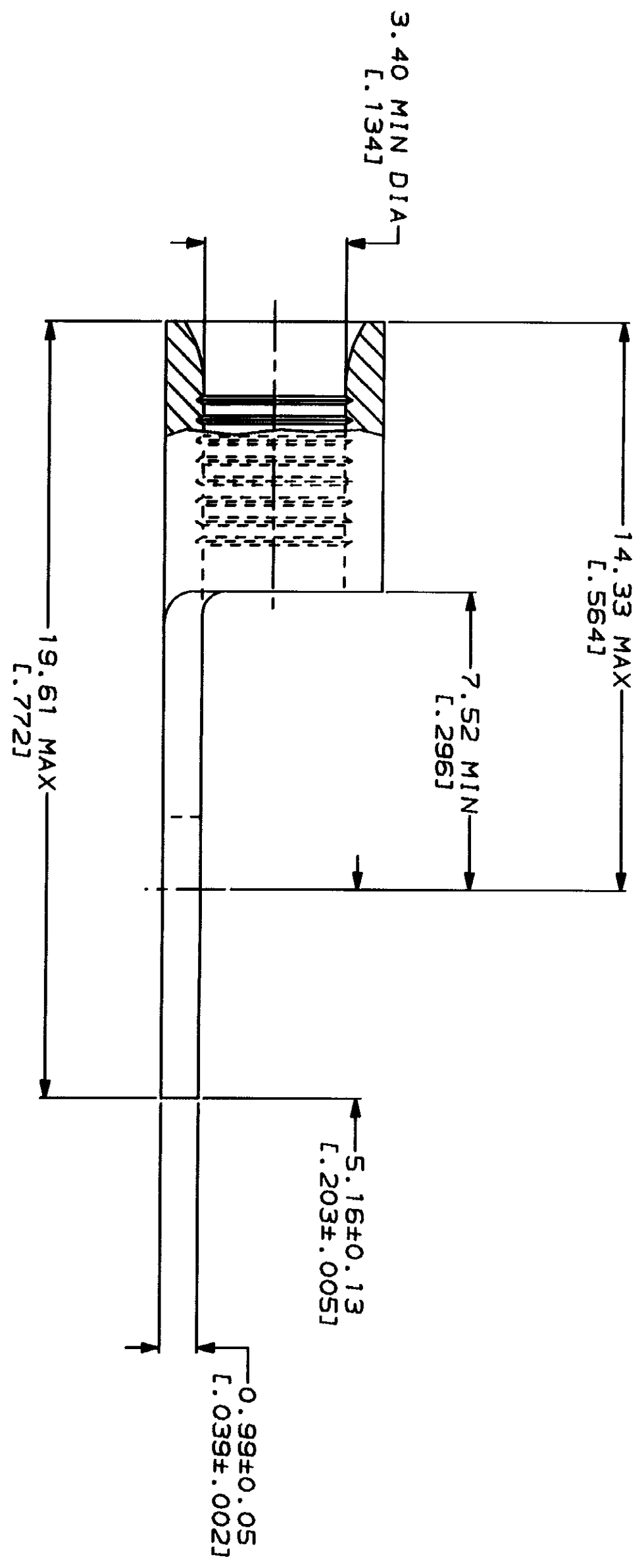
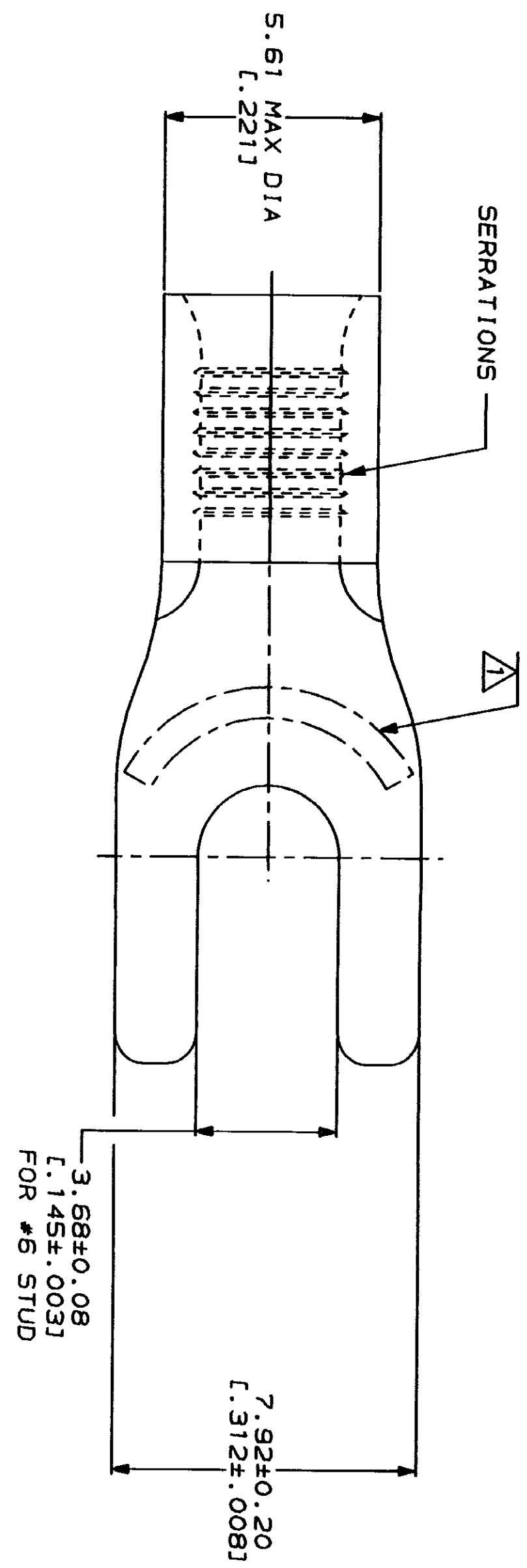

AMP INCORPORATED
 CUSTOMER SERVICE SYSTEMS

FOR ADDITIONAL PRODUCT INFORMATION OR COPIES OF DRAWINGS AND TECHNICAL DOCUMENTS	PRODUCT INFORMATION CENTER 1-800-522-6752
FOR APPLICATION TOOLING INFORMATION	TOOLING ASSISTANCE CENTER 1-800-722-1111
FOR ORDER ENTRY	1-800-526-5142

MAX RECOMMENDED OPERATING TEMPERATURE: 170°C MAX

VOLTAGE RATING: NOT APPLICABLE

WIRE CROSS SECTIONAL AREA RANGE: 2.62-6.64mm² [5,180-13,100] CIR MILS STRANDED

FINISH: TIN PLATE
 0.0025±[L. 000100] MIN THK PER MIL-T-10727

DR 2-18-93 TA BRINKMAN	NAME
CHK 2-18-93 DA PATTERSON	AMP
APPD 2-18-93 DE MILLER	AMP Incorporated Harrisburg, PA 17105-3608
APPD 2-18-93 JL NECKLEY	TERMINAL, SPADE TONGUE, BUDGET
PRODUCT SPEC	SIZE CAGE CODE DRAWING NO 00779 35493
APPLICATION SPEC	SCALE 8:1 SHEET 1 OF 1