

SPECIFICATIONS	
RATING	.4VA MAX. @ 20VDC, OR PEAK AC
TIMING	BREAK BEFORE MAKE
INITIAL CONTACT RESISTANCE	30 MILLIOHMS MAX
INSULATION RESISTANCE	10,000 MEGOHMS MIN
DIELECTRIC WITHSTANDING VOLTAGE	1,000 VRMS AT SEA LEVEL
DURABILITY	10,000 CYCLES @ .4VA RESISTIVE
	30,000 CYCLES @ .1μA 12VDC RESISTIVE
OPERATING FORCE	14 INCH OUNCES
OPERATING TEMPERATURE	-20°C TO +70°C
STORAGE TEMPERATURE	-20°C TO +70°C

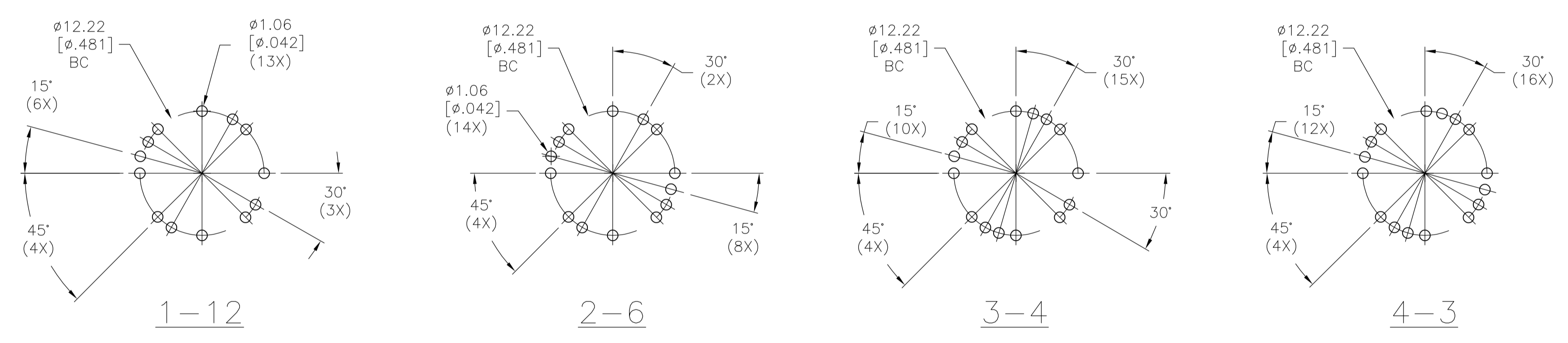

RECOMMENDED PCB HOLE LAYOUTS (VIEWED FROM SHAFT END)
 TOLERANCE ±.002. UNLESS OTHERWISE NOTED.

NOTES:

1. TERMINAL NUMBERS ARE FOR REFERENCE ONLY AND DO NOT APPEAR ON SWITCHES.
2. ALL MATERIALS AND FINISHES SHALL COMPLY WITH EU DIRECTIVE 2002/95/EC OF 27JAN2003 (ROHS).
3. EACH SWITCH SUPPLIED WITH THE FOLLOWING MOUNTING HARDWARE:
 (1) EXTERNAL STOPWASHER EXCEPT FOR MRJ11204 WHICH HAS
 (2) STOPWASHERS.
 (2) HEX NUTS.
 (1) LOCATING RING FOR ANTIROTATION.
 (1) INTERNAL TOOTH LOCKWASHER.

MATERIALS		
COMPONENT NAME	BASE MATERIAL	FINISH
BASE	EPOXY	-
FIXED CONTACT	BRASS	GOLD OVER NICKEL
TERMINAL	BRASS	TIN OVER NICKEL
MOVEABLE CONTACT	PHOSPHOR BRONZE	GOLD OVER NICKEL
ROTOR	PBT	-
BALL	STEEL	-
SPRING	PIANO WIRE	-
STOPPER	STEEL	ZINC
BUSHING	ZINC	NICKEL
SHAFT	BRASS	NICKEL
LOCATING RING	STEEL	ZINC
HEX NUT	BRASS	NICKEL
INTERNAL TOOTH LOCKWASHER	STEEL	ZINC

9 [.35]	3~4 ADJUSTABLE	3	MRJ34904	1825535-5
19 [.75]	4~3 ADJUSTABLE	4	MRJ4304	1825535-4
19 [.75]	3~4 ADJUSTABLE	3	MRJ3404	1825535-3
19 [.75]	2~6 ADJUSTABLE	2	MRJ2604	1825535-2
19 [.75]	1~12 ADJUSTABLE	1	MRJ11204	1825535-1
"A" SHAFT LENGTH	POSITIONS	NO. OF POLES	ALCO P/N	PART NUMBER

THIS DRAWING IS A CONTROLLED DOCUMENT. D4MAY83
 REV B ED
 Tyco Electronics Corporation
 Harrisburg, PA 17105-3608

DIMENSIONS: mm [INCHES]	TOLERANCES UNLESS OTHERWISE SPECIFIED:	0 PLC ± -	1 PLC ± 5.08 [.2]	2 PLC ± 2.54 [1]	3 PLC ± -	4 PLC ± -	ANGLES ± ± 1°
MATERIAL SEE SPECIFICATIONS	FINISH SEE SPECIFICATIONS	WEIGHT -	SIZE A1	CAGE CODE 00779	DRAWING NO. 1825535	RESTRICTED TO -	

CUSTOMER DRAWING SCALE 3:1 SHEET 1 OF 1 REV A2