

NUMBER
C-1775002

3RD ANGLE PROJECTION

METRIC

THIS INFORMATION IS CONFIDENTIAL AND IS DISCLOSED TO YOU ON CONDITION THAT NO FURTHER DISCLOSURE IS MADE BY YOU TO OTHER THAN AMP PERSONNEL WITHOUT WRITTEN AUTHORIZATION FROM AMP (TAIWAN) LTD. DIMENSIONS IN MILLIMETERS. DO NOT SCALE PRINT.

PRINT DIST
DW

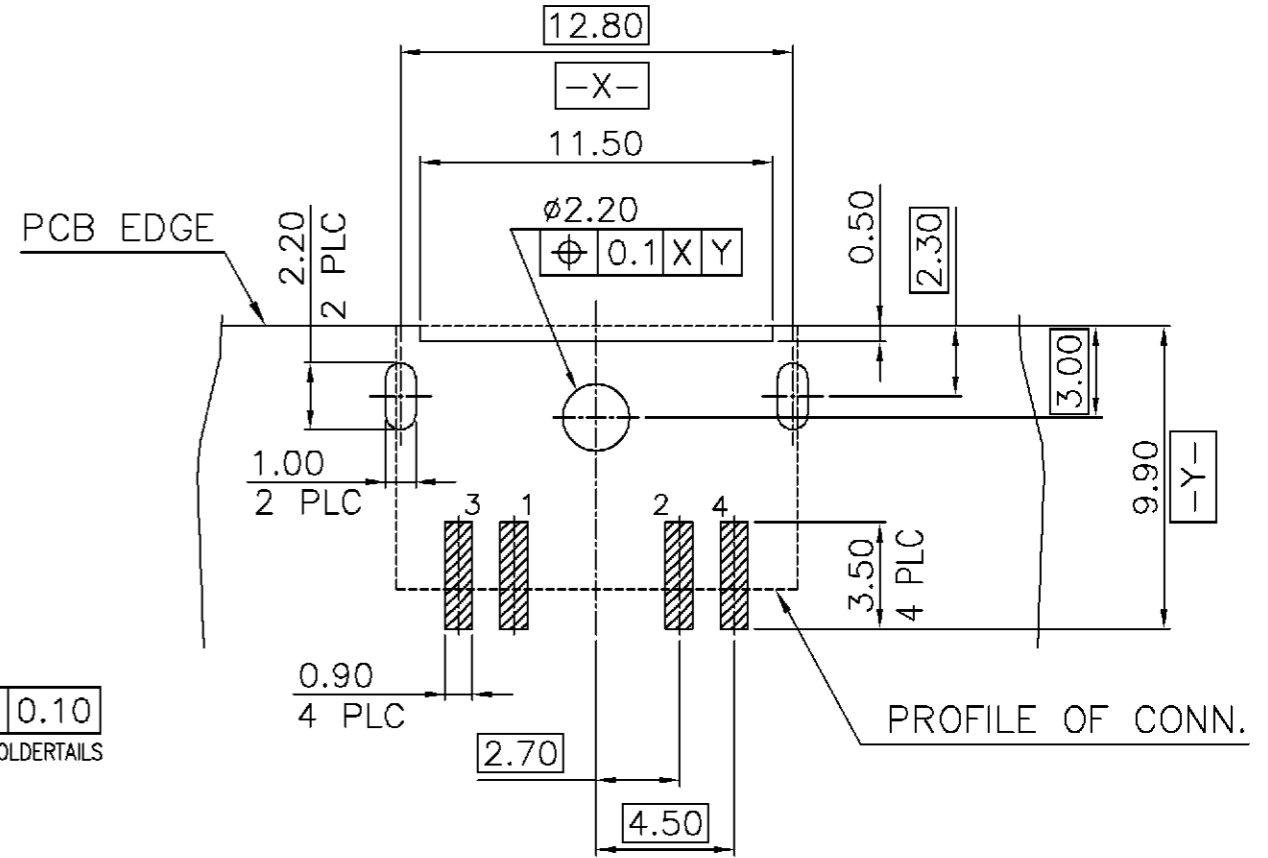
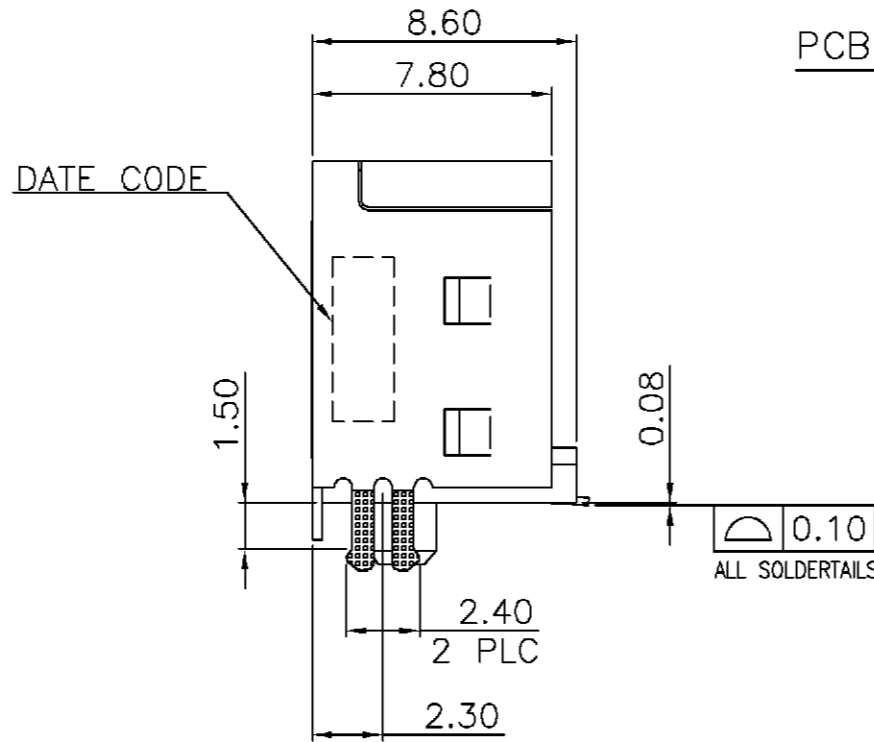
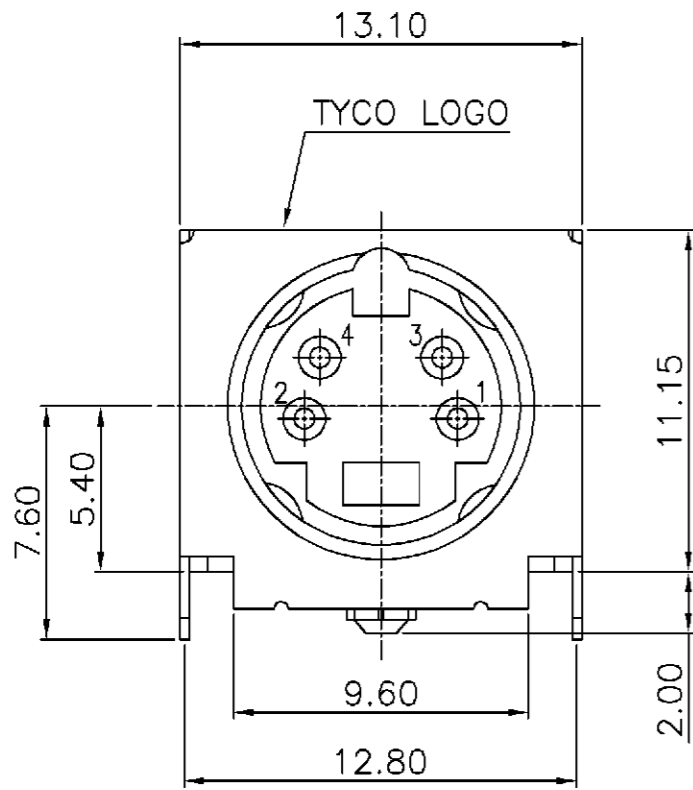

RECOMMENDED PCB LAYOUT (TOP VIEW)
TOLERANCE: ± 0.05 (THICKNESS=1.2mm)

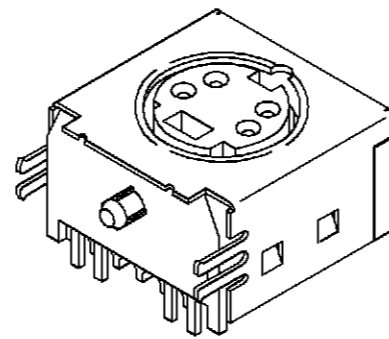
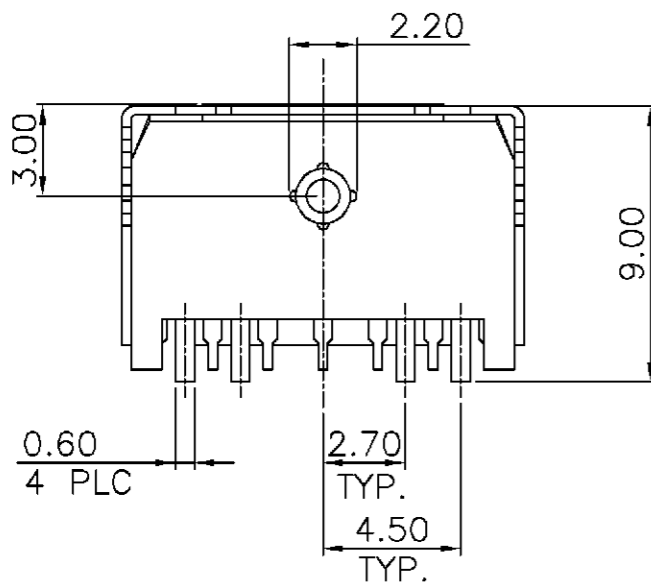

NOTES:

- MATERIAL:
HOUSING: THERMOPLASTIC WITH 30% GLASS FIBER FILLED
UL 94V-0 RATED. COLOR: BLACK.
CONTACT: PHOSPHOR BRONZE, THICKNESS=0.25mm.
SHIELD: BRASS, THICKNESS=0.30mm.
- FINISH:
CONTACT: GOLD FLASH PLATED IN CONTACT AREA,
120u" MIN. MATTE TIN PLATED IN SOLDERTAILS AREA,
50u" MIN. NICKEL UNDERPLATED ALL OVER.
SHIELD: 120u" MIN. MATTE TIN PLATED OVER 100u" MIN.
NICKEL UNDERPLATED ALL OVER.
- NET WEIGHT : 2.04 gram.
- APPLIED TO REFLOW SOLDERING PROCESS.

1775002-1

PART NUMBER

TOLERANCES UNLESS OTHERWISE SPECIFIED:		DWN	O. HU	tyco Electronics	TYCO HOLDINGS (BERMUDA) VII LTD. TAIWAN BRANCH	
0 PLC \pm			01-OCT-2004			
1 PLC ± 0.35		CHK	S. HOU	NAME		
2 PLC ± 0.25			01-OCT-2004			
3 PLC \pm						
ANGLES \pm						
MATERIAL		APVD	W.J. KE	MINI DIN, 4 POS, SMT TYPE		
SEE NOTE			01-OCT-2004			
FINISH		PRODUCT SPEC		LOC		
SEE NOTE		108-57512		SIZE	DRAWING NO	
		QUALIFICATION TEST REPORT		A ₃	C-1775002	
		501-57585		SCALE	REV	
		WEIGHT		--	A	
				SHEET		
				1 OF 2		

A	REVISED PACKAGE DRAWING	FZ00-0284-04	OH	03-DEC
O	FIRST RELEASED	FZ00-0219-04	OH	01-OCT
LTR	REVISION RECORD	ECN	DWN	DATE

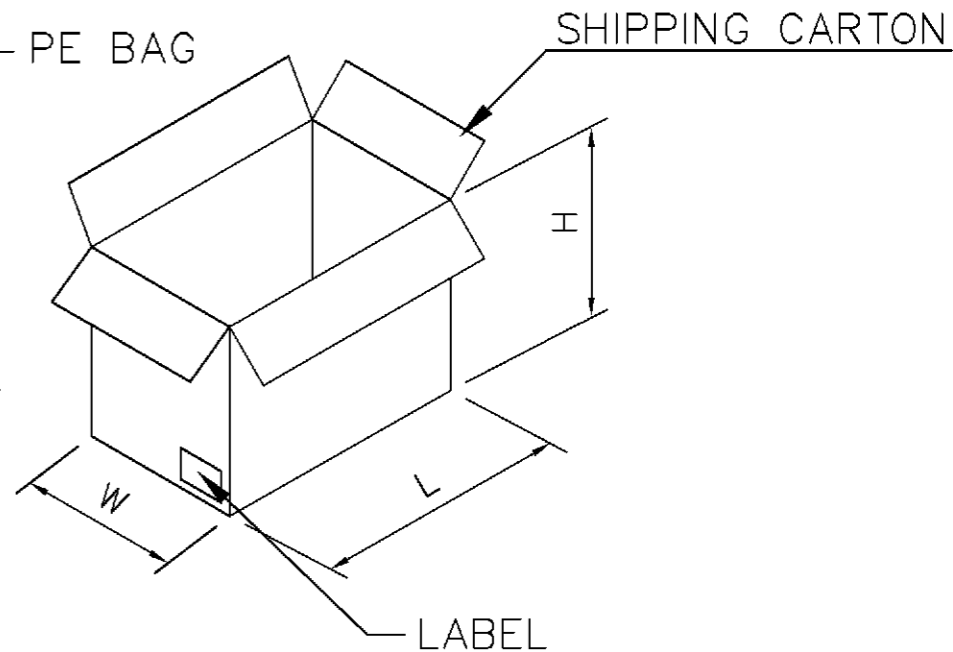
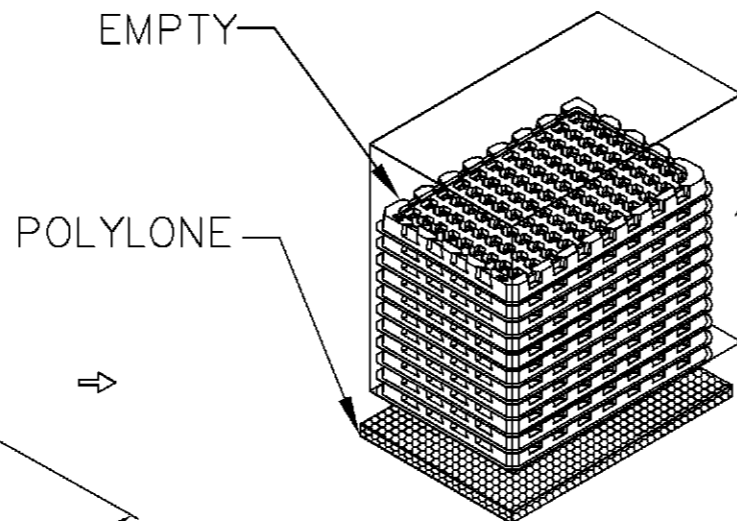
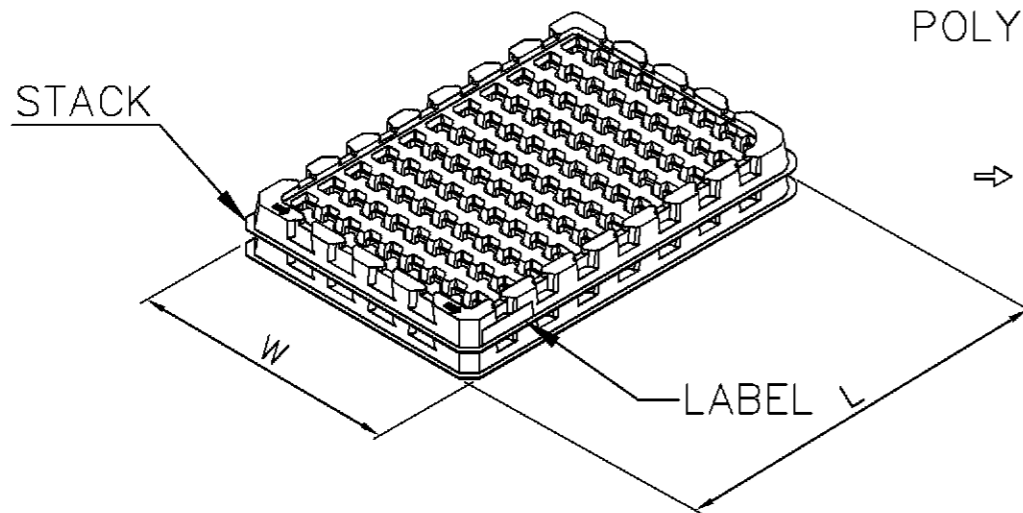
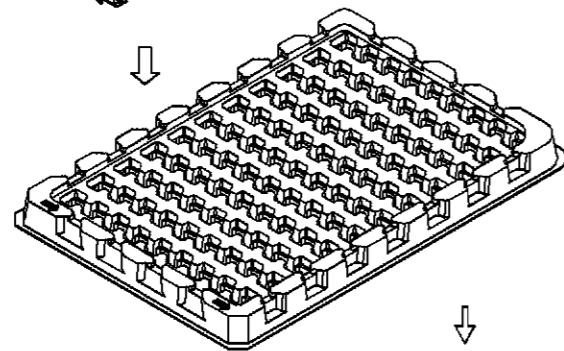
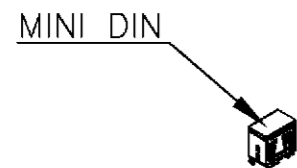

NOTES:

1. TRAY: PVC
SHIPPING CARTON: CORRUGATED FIBERBOARD
2. DIMENSION :
TRAY : L=335mm, W=230mm, H=21.8mm
SHIPPING CARTON : L=345mm, W=234mm, H=215mm
POLYSTYRENE : L=340, W=234, H=15
3. QUANTITY :
PRIMARY PACKING: 99 PCS/TRAY
SECONDARY PACKING: 10 TRAY/CARTON(990PCS)
- 4.WEIGHT:
NET WEIGHT : 9.06 Kg
GROSS WEIGHT : 15 Kg

SEE SHEET 1.	ECN	DWN	CHK	DATE
LTR	REVISION RECORD			

TOLERANCES UNLESS OTHERWISE SPECIFIED: 0 PLC ± 1 PLC ± 2 PLC ± 3 PLC ± ANGLES ±	DWN	O. HU	tyco		TYCO HOLDINGS (BERMUDA)	
		01-OCT-2004	Electronics		VII LTD. TAIWAN BRANCH	
MATERIAL SEE NOTE	CHK	S. HOU	NAME			
		01-OCT-2004	MINI DIN, 4 POS, SMT TYPE			
FINISH SEE NOTE	APVD	W.J. KE	LOC	SIZE	DRAWING NO	REV
		01-OCT-2004	DW	A ₃	C-1775002	A
	APPLICATION SPEC		SCALE	SHEET		
	WEIGHT		--	2 OF 2		