

**AMP**

AMP INCORPORATED  
HARRISBURG, PA 17105

TOOLING ASSISTANCE 1 800 722-1111  
AMP FAX/PRODUCT INFO 1 800 522-6752

**AMP\* STANDARD HIGH VOLTAGE (SHV)  
COAXICON\* JACK AND BULKHEAD JACK  
CONNECTORS 225087-[ ] AND 225059-[ ]  
(DUAL CRIMP TYPE)**

**IS 9821**

RELEASED  
9-9-92

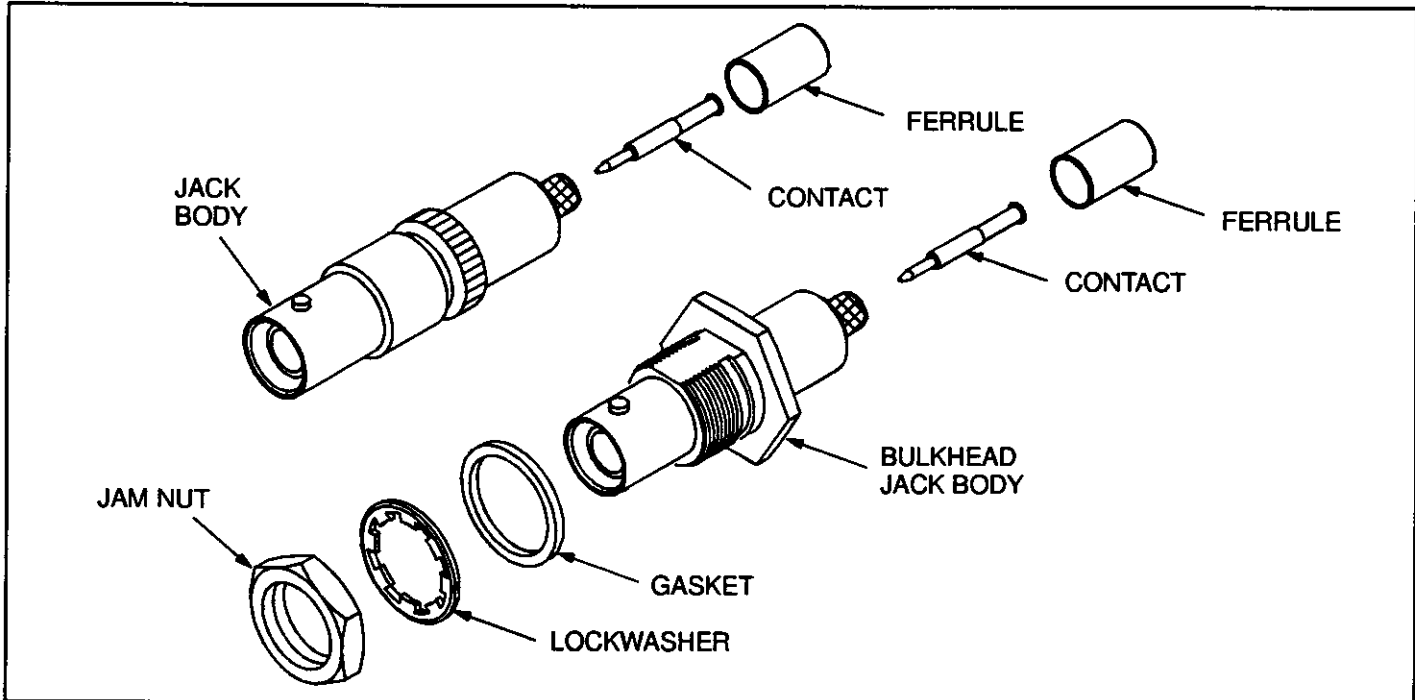

Fig. 1

cad

**1. INTRODUCTION**

This Instruction Sheet (IS) covers the assembly of AMP SHV COAXICON Jack and Bulkhead Jack (Dual Crimp Type) Connectors 225087-[ ] and 225059-[ ] designed to provide shielded disconnects for high-voltage applications. The jack and bulkhead jack connectors accept a wide range of coaxial cables and can be crimped using the following tools: AMP Double Action Hand Tool 220022-1 (IS 6872), AMP Single Action Hand Tool 69710 (IS 2095), and AMP Pneumatic Hand Tools 69365 and 69365-3 (CM 1983). For details concerning connector crimping procedures, refer to the instructions packaged with the appropriate tool. To select the appropriate connector and cable size and recommended crimping tools, refer to AMP Catalog 82074. Connector performance requirements and test data are available in AMP Product Specification 108-12012. For application requirements, refer to AMP Application Specification 114-12013.

bulkhead jack body, a contact, a ferrule, a gasket, a lockwasher, and a jam nut.

**3. ASSEMBLY PROCEDURE**

**A. Jack Connector**

- Slide ferrule over the end of the cable; then strip cable using the recommended strip-length dimensions in Figure 2. DO NOT nick or cut cable braid. Center conductor must be straight and free of burrs.

**NOTE** Dimensions on this instruction sheet are in millimeters [followed by inches in brackets].

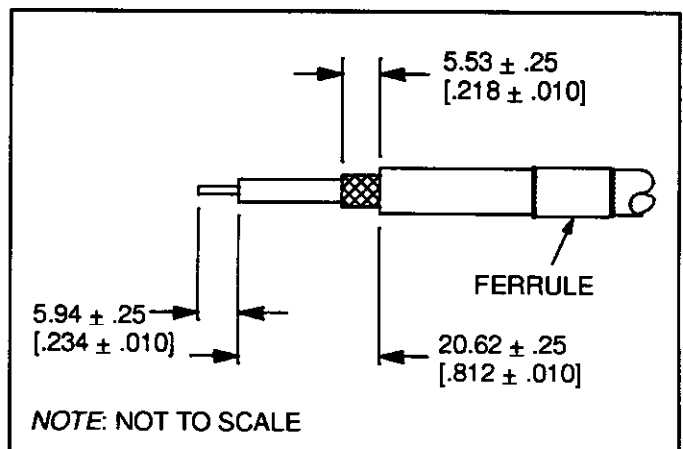

Fig. 2

cad

**2. DESCRIPTION (Figure 1)**

The jack connector consists of a jack body, a contact, and a ferrule. The bulkhead jack connector consists of a

2. Insert center conductor into contact; then crimp contact using recommended crimping tool(s) referenced in AMP Catalog 82074. See Figure 3.

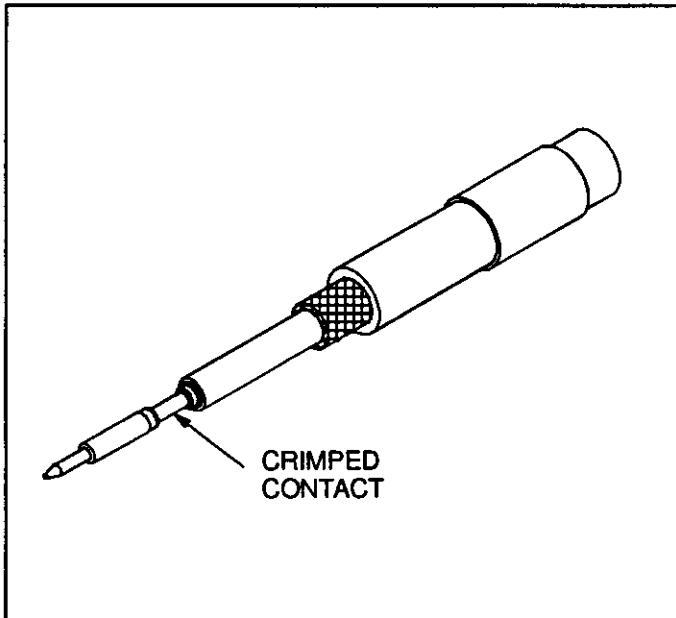

Fig. 3

cad

3. Flare cable braid. Insert contact into jack body until it snaps into place. Make sure that the cable braid is positioned over the support sleeve of the jack body. Gently pull back on the cable to ensure that the contact is held in place by the internal locking feature. See Figure 4.

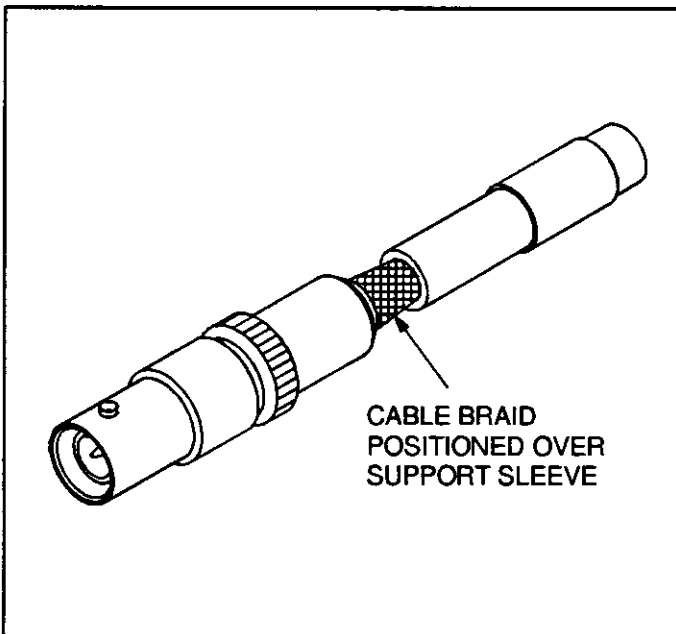

Fig. 4

cad

4. Slide ferrule forward over braid and support sleeve; then crimp ferrule using the appropriate crimping tool. See Figure 5.

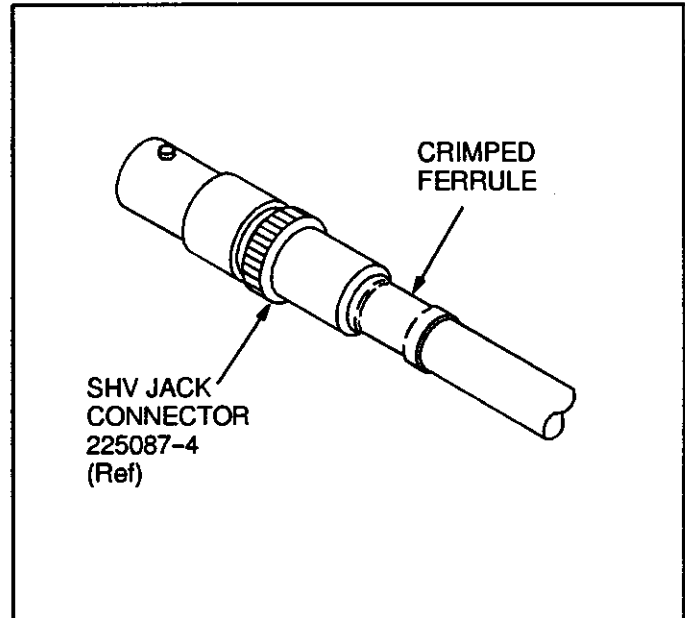

Fig. 5

cad

#### B. Bulkhead Jack Connector

1. Prepare cable using the strip-length dimensions in Figure 2. Insert center conductor into contact; then crimp contact using recommended crimping tool(s) referenced in AMP Catalog 82074. See Figure 6.

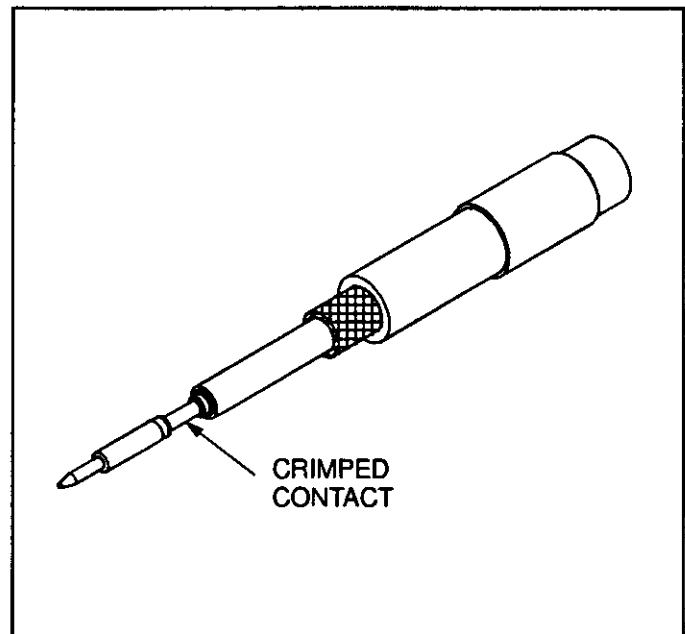

Fig. 6

cad

2. Flare cable braid. Insert contact into bulkhead jack body until it snaps into place. Make sure that the cable braid is positioned over the support sleeve of the bulkhead jack body. Gently pull back on the cable to ensure that the contact is held in place by the internal locking feature. See Figure 7.

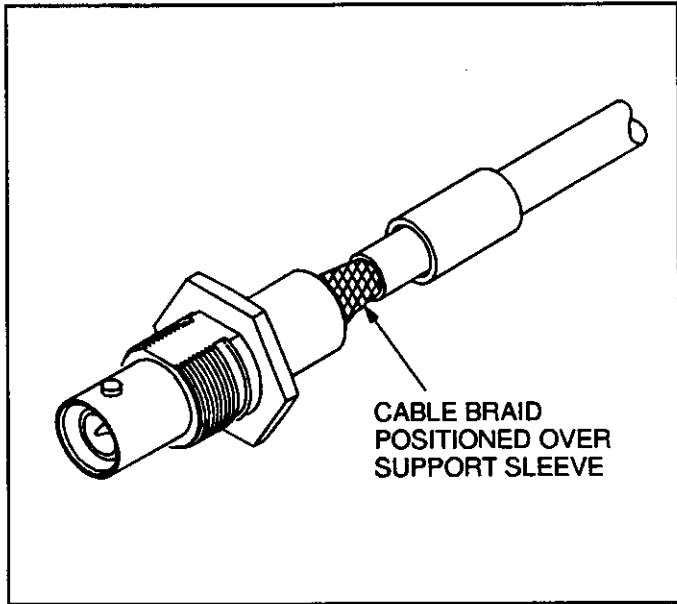

Fig. 7

cad

3. Slide ferrule forward over braid and support sleeve; then crimp ferrule using the recommended

crimping tool (refer to AMP Catalog 82074). See Figure 8.

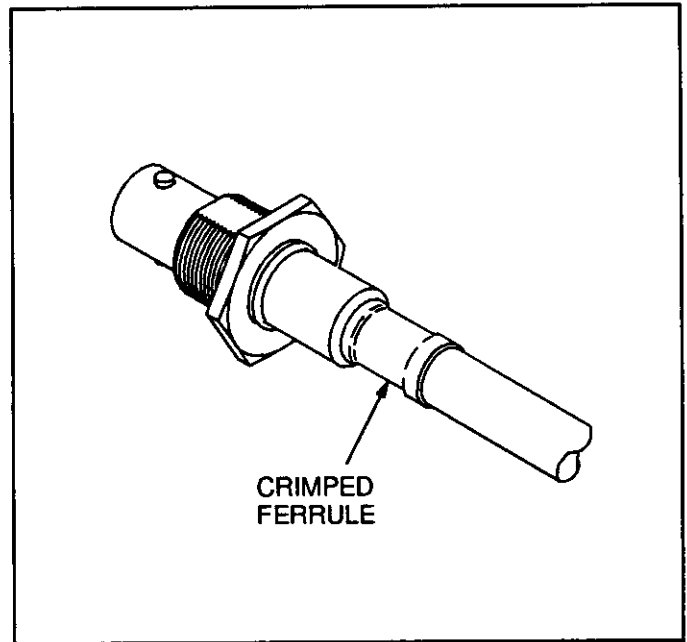

Fig. 8

cad

4. Make the panel cutout using the dimensions in Figure 9. Install gasket onto connector assembly; then insert connector through the cutout. Secure connector with lockwasher and jam nut.

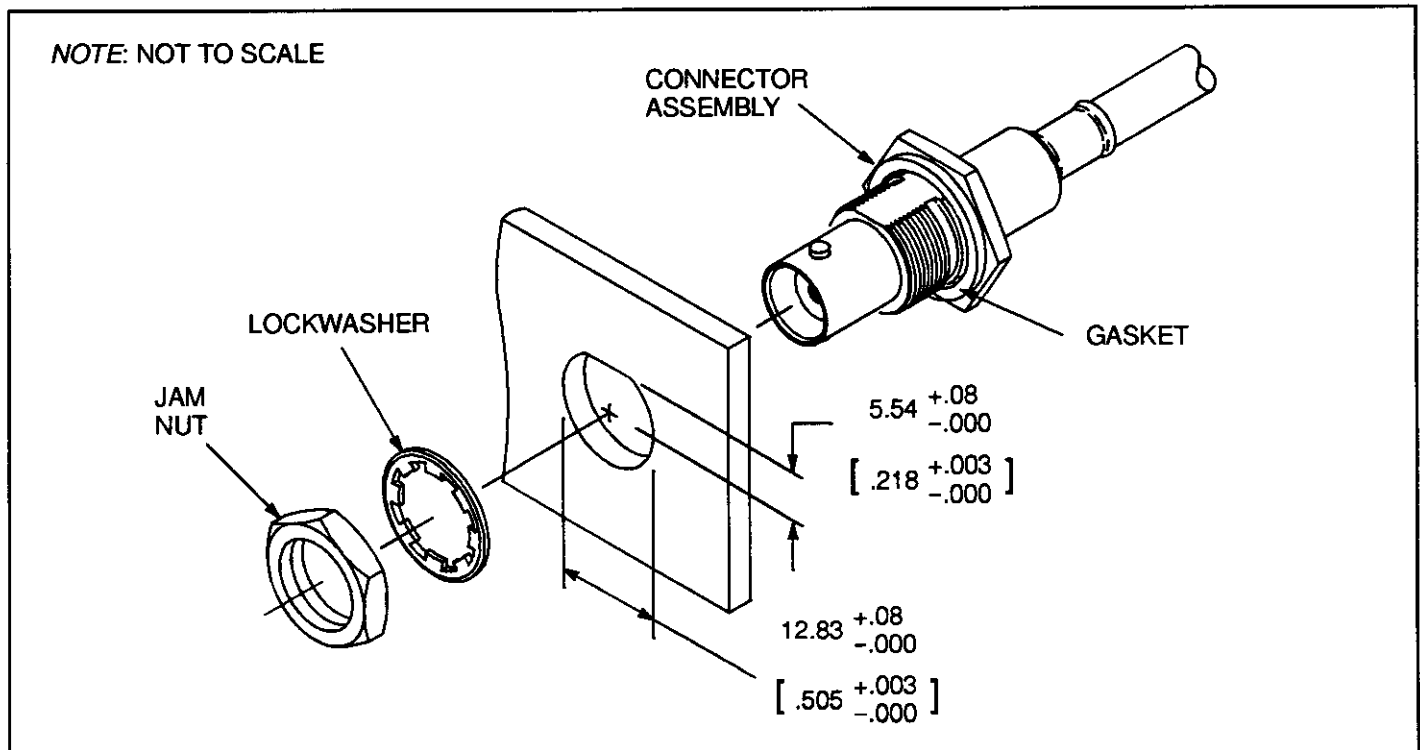

Fig. 9

cad