

NOTE



All numerical values are in metric units [with U.S. customary units in brackets]. Dimensions are in millimeters [and inches]. Unless otherwise specified, dimensions have a tolerance of ± 0.13 [$\pm .005$] and angles have a tolerance of $\pm 2^\circ$. Figures and illustrations are for identification only and are not drawn to scale.

1. INTRODUCTION

This specification covers requirements for the application of AMPLIMITE HD-22 Straight Front Metal Shell Connectors designed for printed circuit (pc) boards. The connectors are available with boardlocks and 4-40 threaded inserts, nonremovable 4-40 female screwlocks, or through holes in the mounting flange. Connectors are designed to be placed on the pc board manually.

Front Metal Shell Connector receptacles are available in 15, 26, 62, and 78 positions; plugs are available in 15 and 78 positions. The connector plugs contain pin contacts and the receptacles contain socket contacts. This document supercedes Application Specification 114-40022.

Figure 1 provides connector features and terms used throughout this specification. Use these terms when corresponding with Tyco Electronics Representatives to facilitate assistance. The connector illustrations present composites of mounting options and do not depict actual applications.

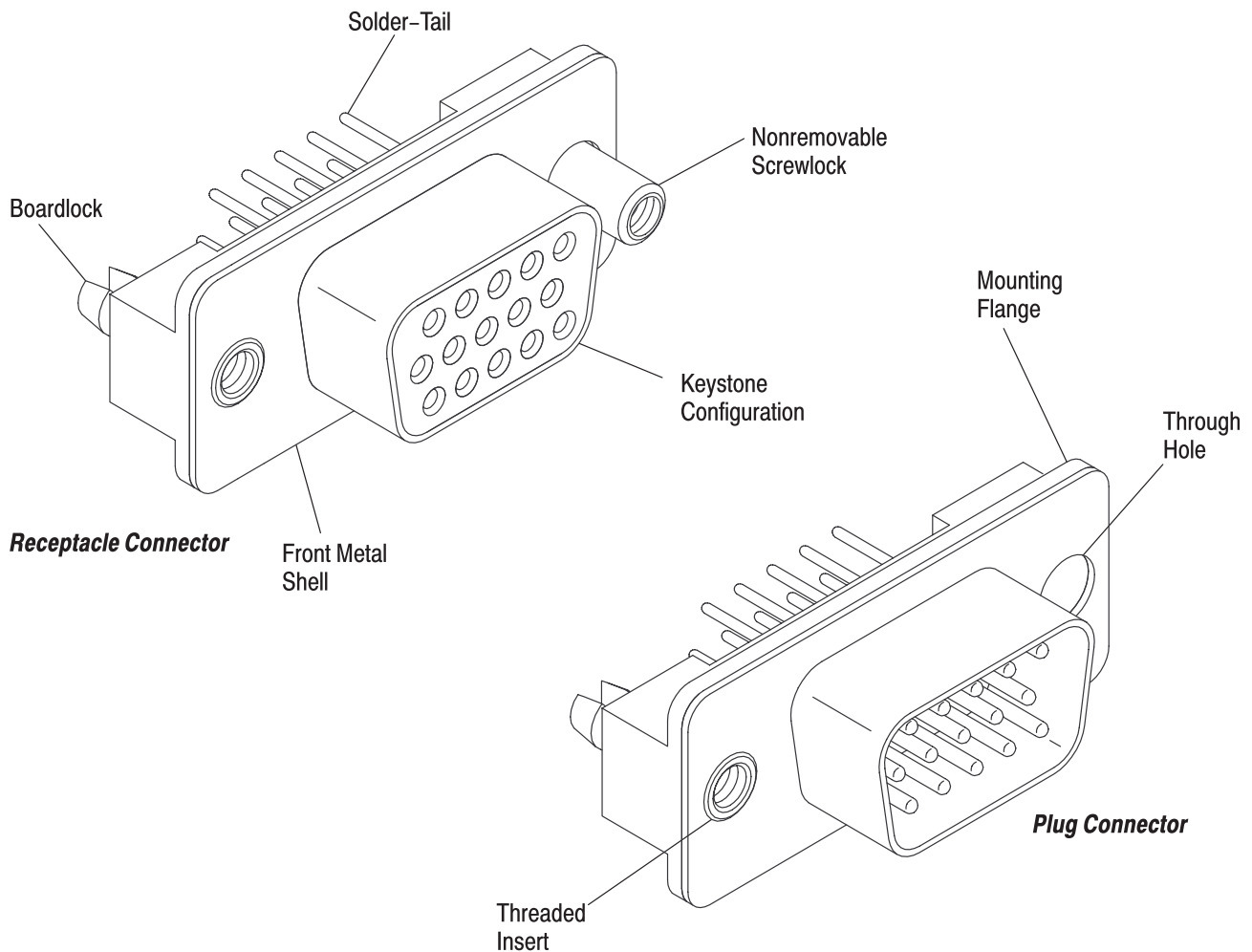

Figure 1

2. REFERENCE MATERIAL

2.1. Revision Summary

This paragraph is reserved for a revision summary covering the most recent additions and changes made to this specification which include the following:

- Initial release of document

2.2. Customer Assistance

Reference Base Part Number 5786382 and Product Code 4519 are representative of AMPLIMITE HD-22 Straight Front Metal Shell PC Board Connectors. Use of these numbers will identify the product line and expedite your inquiries through a service network established to help you obtain product and tooling information. Such information can be obtained through a local Tyco Electronics Representative or, after purchase, by calling the Tooling Assistance Center or Product Information number at the bottom of page 1.

2.3. Drawings

Customer Drawings for each product part number are available from the service network. The information contained in Customer Drawings takes priority if there is a conflict with this specification or with any technical documentation supplied by Tyco Electronics.

2.4. Manuals

Manual 402-40 is available upon request and can be used as a guide in soldering. This manual provides information on various flux types and characteristics along with commercial designations and flux removal procedures. A checklist is included in the manual as a guide for information on soldering problems.

2.5. Specifications

Product Specification 108-1092 provides test results and performance requirements.

3. REQUIREMENTS

3.1. Storage

A. Ultraviolet Light

Prolonged exposure to ultraviolet light may deteriorate the chemical composition used in connectors.

B. Shelf Life

The connectors should remain in the shipping containers until ready for use to prevent damage. The products should be used on a first in, first out basis to avoid storage contamination that could adversely affect signal transmissions.

C. Chemical Exposure

Do not store connectors near any chemicals listed below, as they may cause stress corrosion cracking in the components.

Alkalies	Ammonia	Citrates	Phosphates	Citrates	Sulfur Compounds
Amines	Carbonates	Nitrites	Sulfur Nitrites		Tartrates

NOTE



Where the above environmental conditions exist, phosphor-bronze contacts are recommended instead of brass if available.

3.2. Connector Shell Sizes

There are four industry standard shell sizes available for these connectors. A composite of the four receptacle sizes with the overall dimension for each is provided in Figure 2.

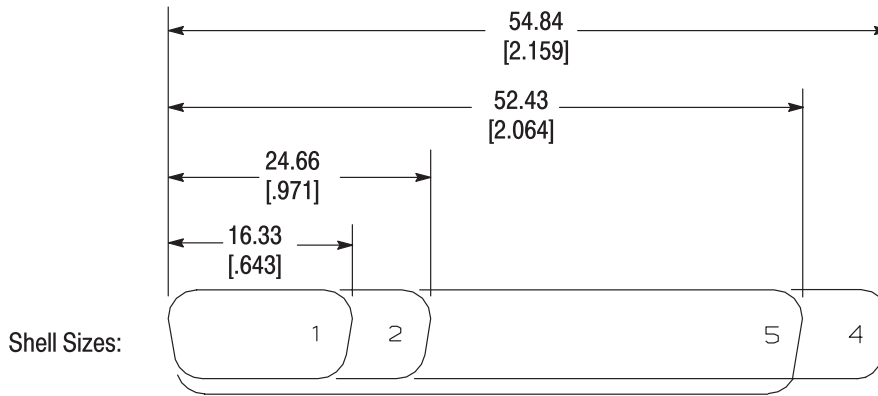
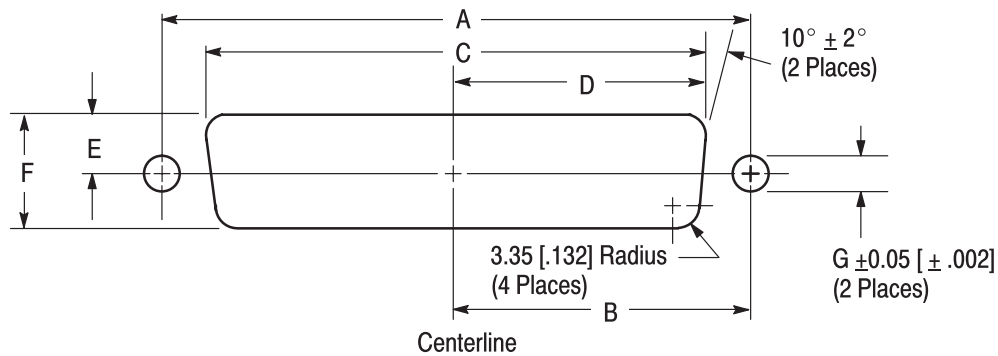

Figure 2

3.3. Panel Mounting Cutout

Panel mounting is optional for AMPLIMITE Straight Front Metal Shell PC Board Connectors. For pc board connectors, it will provide additional support for the solder joints during mating and unmating. The pc board connectors can ONLY be rear mounted. Either front or rear mounting is acceptable for the mating cable connector. Connector mounting flanges that have 4–40 internal threads will accept screwlocks or panel mounting screws. Hardware attached to the connector flange shall be tightened to 0.45 N•m [4 in.-lb] maximum. See Figure 3 for panel cutout dimensions.

Screwlocks are designed to secure a connector to a panel 1.58 mm [.062 in.] thick. They can be used with thinner panels; however, washers are recommended to make up the thickness difference and provide a bottoming surface for the mating connector flange. Screwlocks should be tightened to a torque of 0.45 N•m [4 in.-lb] maximum. The 4–40 internal threads in the screwlocks will accept commercially available 4–40 threaded screws and jackscrews.



NUMBER OF POSITIONS	DIMENSIONS						G	
	A	B	C	D	E	F	WITH FIXED FEMALE SCREWLOCKS	WITHOUT FIXED FEMALE SCREWLOCKS
15	24.99 [.984]	12.50 [.492]	20.47 [.806]	10.24 [.403]	5.72 [.225]	11.40 [.449]	5.74 [.226]	3.05 [.120]
26	33.32 [1.312]	16.66 [.656]	28.80 [1.134]	14.40 [.567]	5.72 [.225]	11.40 [.449]		
62	63.50 [2.500]	31.75 [1.250]	59.08 [2.326]	29.54 [1.163]	5.72 [.225]	11.40 [.449]		
78	61.11 [2.406]	30.56 [1.203]	56.34 [2.218]	28.17 [1.109]	7.06 [.278]	14.10 [.555]		

Figure 3

3.4. Mating Dimensions

The dimensions shown in Figure 4 must be considered when determining method of mounting and thickness of the panel when connectors are to be panel-mounted. This dimension ensures full mating of connectors.

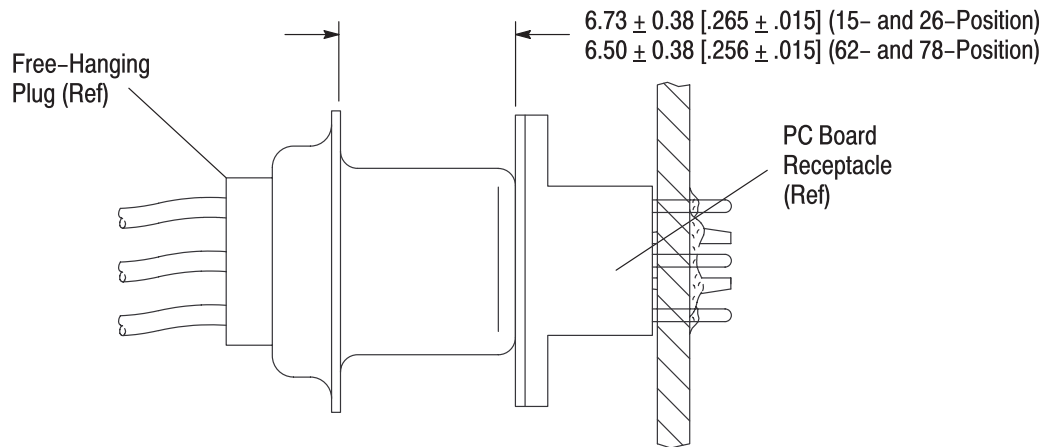

Figure 4

3.5. Connector Spacing

Care must be used to avoid interference between adjacent connectors and/or other components. The dimension depends on variable hardware used and the clearance required for mating connectors. The information provided in Figure 5 is to ensure proper mating for manual placement of connectors.

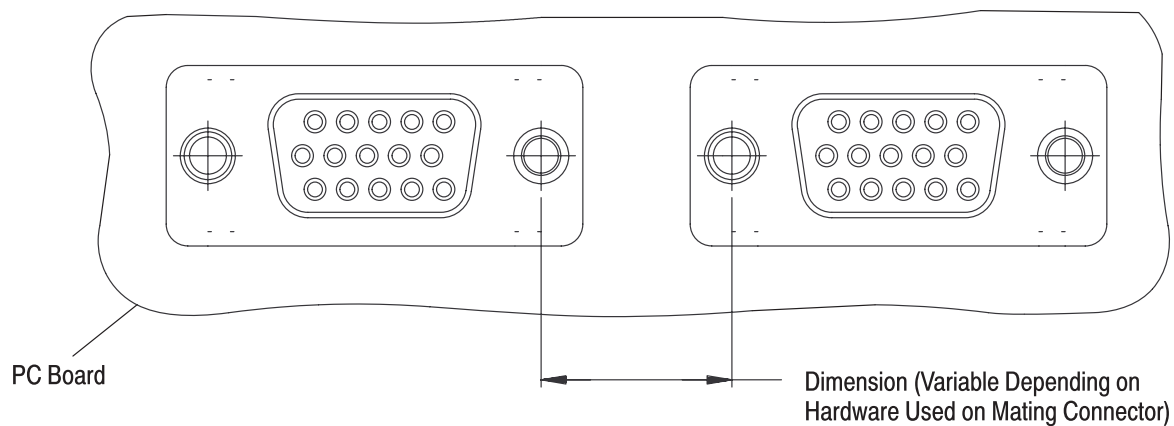

Figure 5

3.6. PC Boards

A. Material and Thickness

1. Board material will be glass epoxy (FR-4, G-10).
2. AMPLIMITE HD-22 Straight Front Metal Shell Connectors are designed to accommodate a range of applications. Boardlocks are designed for 1.57 mm [.062 in.] thick pc boards.

Contact the Product Information Center or the Tooling Assistance Center number listed at the bottom of page 1 for suitability of other board materials or thicknesses.

B. Tolerance

Maximum allowable bow of the pc board shall be 0.03 mm [.001 in.] over the length of the connector.

C. PC Board Layout

The mounting and contact holes in the pc board must be precisely located to ensure proper placement and optimum performance of the connector. The following dimensions must be observed when preparing a pc board for AMPLIMITE HD-22 Straight Front Metal Shell Connectors. Design the pc board using the dimensions provided in Figure 6.

Connector Mating Face is on this Side of PC Board

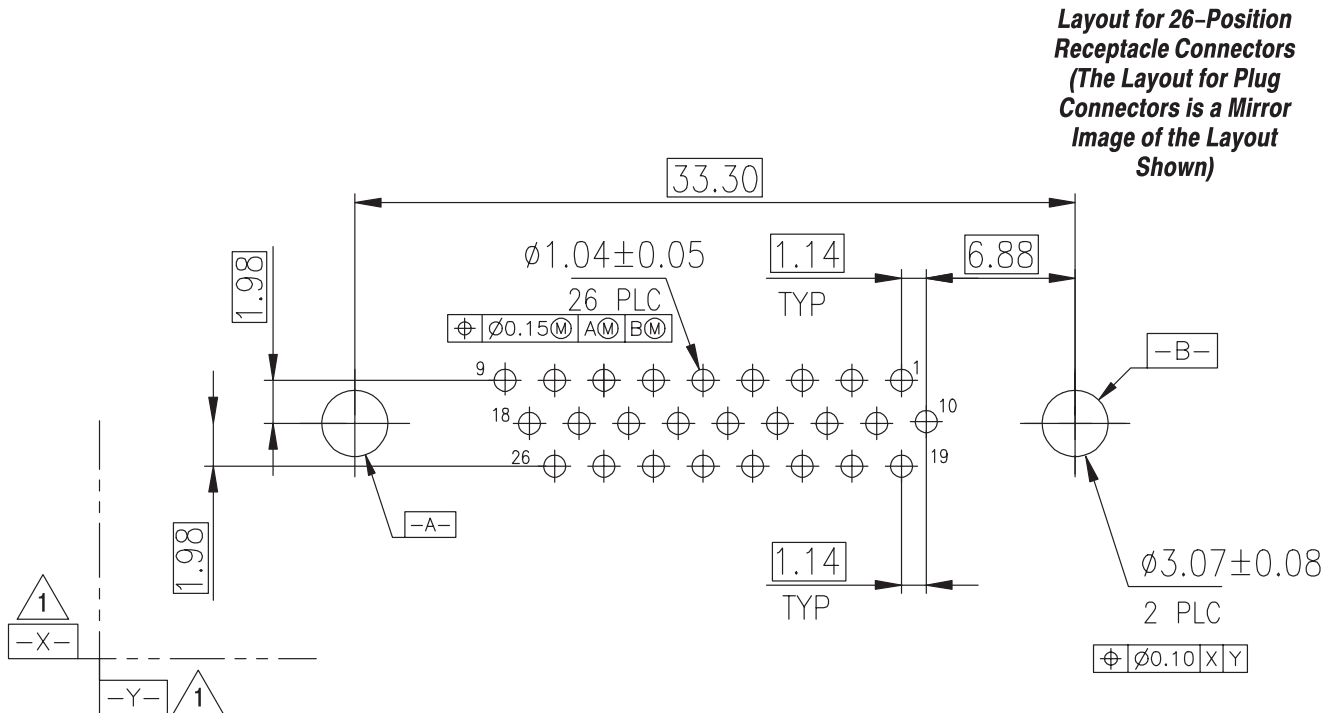
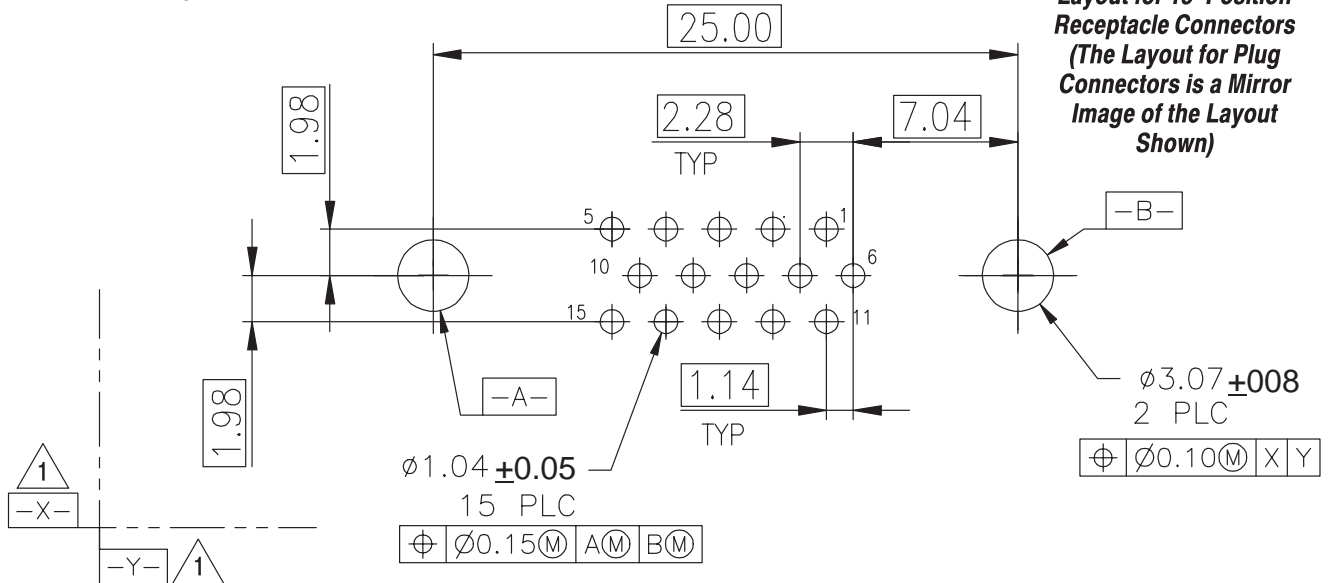

1 Datum and Basic Dimensions Established by Customer

Figure 6 (cont'd)

Connector Mating Face is on this Side of PC Board

**Layout for 62-Position Receptacle Connectors
(The Layout for Plug Connectors is a Mirror Image of the Layout Shown)**

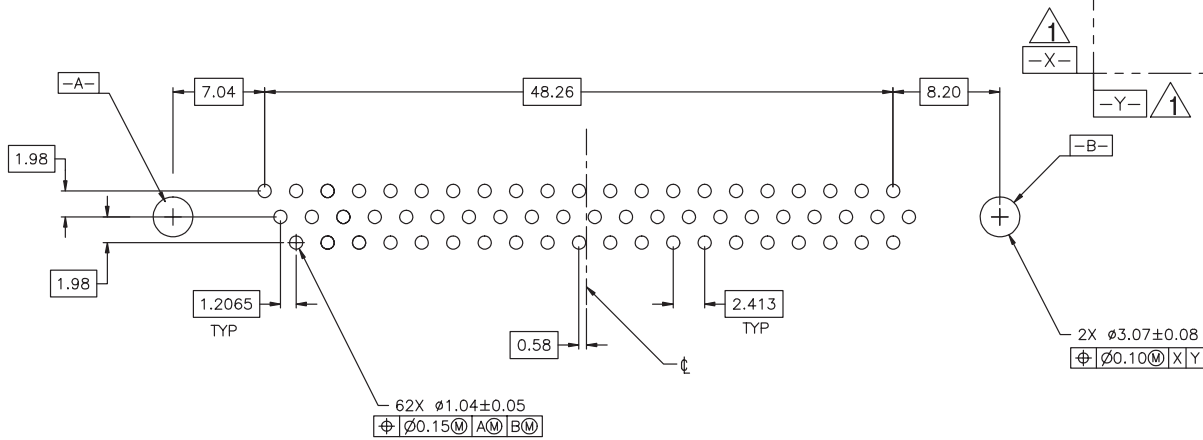

**Layout for 78-Position Receptacle Connectors
(The Layout for Plug Connectors is a Mirror Image of the Layout Shown)**

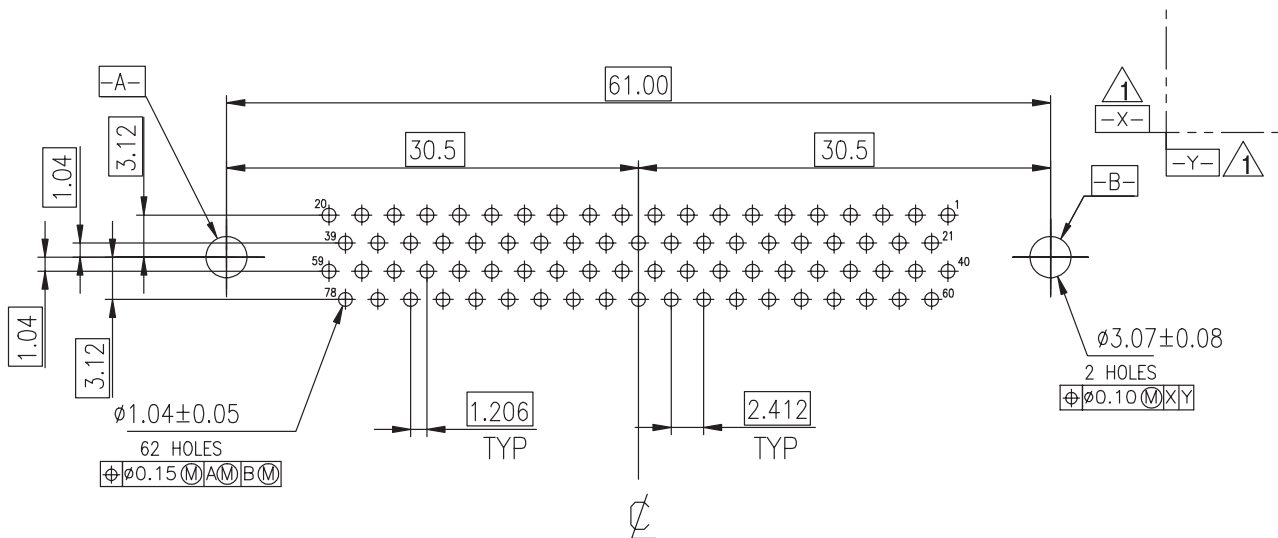

1 Datums and Basic Dimensions
Established by Customer

Figure 6 (end)

3.7. PC Board Solder-Tail Holes

These connectors may be used with or without plated through holes. If plated, the drilled hole size, plating types, and plating thickness are dependent on your application requirements. The finished hole size must be as stated to provide unrestricted insertion and ensure adequate application of solder to the tails. See Figure 7.

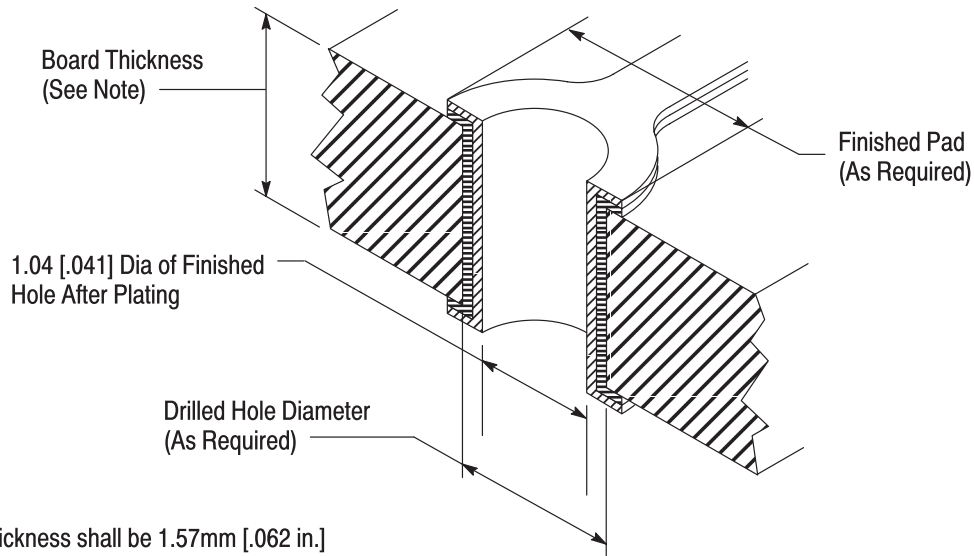

NOTE: Board thickness shall be 1.57mm [.062 in.]

Figure 7

3.8. Limitations

Use the Product Specification referenced in Paragraph 2.5 for test procedures regarding these connectors.

3.9. Polarizing and Keying

The keystone configuration of each connector mating face prohibits the accidental inversion of mating connectors. To further reduce the possibility of incorrect mating of similar plug connectors, a keying plug may be placed in the receptacle connector. See Figure 8.

NOTE *If a keying plug is used, the pin cavity in the mating plug connector must be empty.*

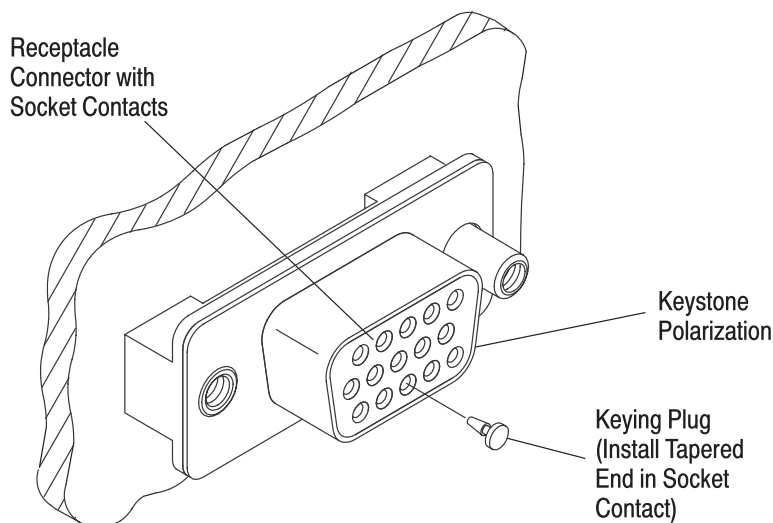

Figure 8

3.10. PC Board Connectors

The boardlocks in these connectors have gripping shoulders that pass through the pc board at the same time the contact solder-tails are inserted through the board. They retain the housing seated on the board.

3.11. Ancillary Items

A. PC Board Mounting Hardware

The procedure for attaching connectors will depend on whether the connector flange has through holes or mounting hardware. See Figure 9.

- **Connector Flanges with Through Holes**

Attach connector to pc board using commercially available hardware such as screws, washers, and nuts, removable screwlocks, rivets, or other suitable hardware. Threaded hardware should be torqued to a value of $0.45 \text{ N}\cdot\text{m}$ [4 in-lb]. The connectors must not be secured with incompatible, dissimilar metals without appropriate interface treatment.

- **Connector Flanges with Threaded Hardware**

Threaded inserts have 4–40 threads and accept the same types of mounting hardware (removable screwlocks, common screws, cross-recessed screws, etc.). If a removable insert is used with one of these connectors, it should be tightened to a torque value of $0.45 \text{ N}\cdot\text{m}$ [4 in-lb].

B. Mating Connector Hardware

Connectors with nonremovable screwlocks can be secured to mating connectors with commercially available 4–40 hardware. Connectors with nonremovable 4–40 threaded inserts in the mounting flange can be attached to the mounting panel with commercially available 4–40 hardware. The torque limit for hardware used to secure mating connectors to each other is $0.23 \text{ N}\cdot\text{m}$ [2 in-lb].

Connector with Standard Mounting Holes using Removable Long Female Screwlock Kit

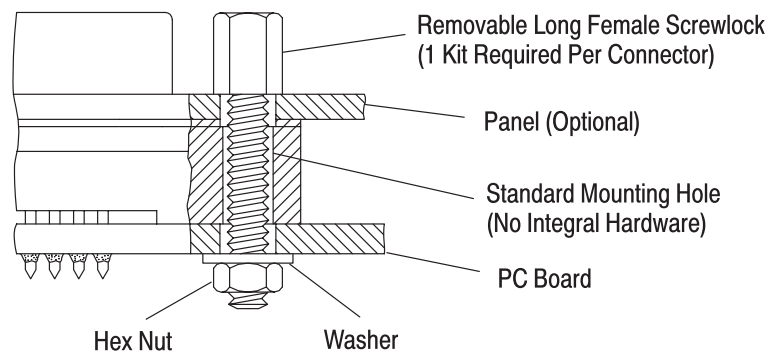
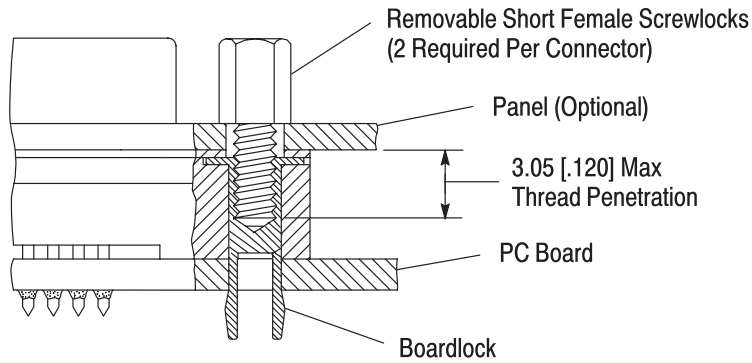

Figure 9 (cont'd)

Connector with 4-40 Threaded Insert and Boardlock using Removable Short Female Screwlocks



Connector with 4-40 Fixed Female Screwlocks

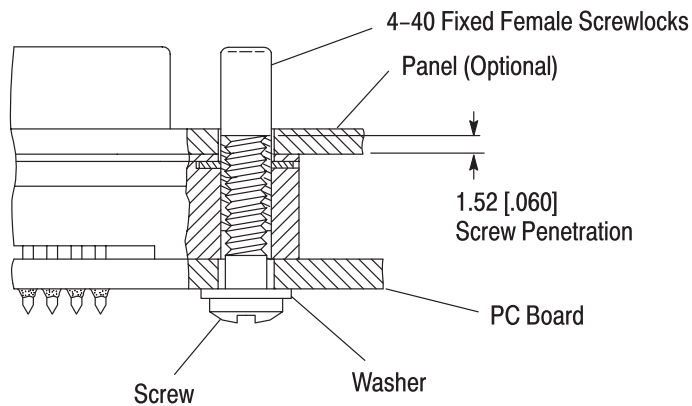

Figure 9 (end)

3.12. Shielding

These connectors feature nickel-plated steel shells which provide continuity for EMC (Electro Magnetic Compatibility) applications. When mated with corresponding metal shell connectors, shielding and grounding continuity are achieved. Use of screws and nuts or retention inserts provide electrical continuity to any ground path on the pc board inclusive of hardware mounting holes.

3.13. Connector Placement



The connector should be handled only by the housing to avoid deformation, contamination, or other damage to the solder-tails.

Determine which hole in the pc board is to receive the number one contact solder-tail, then orient the connector so the number one solder-tail is aligned with the hole. Start all solder-tails into the board; then, when the boardlock starts to engage the board, press evenly on the connector until it seats on the pc board.

After the connector is snapped into the pc board, the boardlocks are soldered with the connector solder-tails during the soldering process.

3.14. Soldering

A. Flux Selection

Contact solder-tails must be fluxed prior to soldering with a mildly active flux. Selection of the flux will depend on the type of pc board and other components mounted on the board. Additionally, the flux must be compatible with the wave solder line, manufacturing, health, and safety requirements.

B. Soldering Guidelines

AMPLIMITE HD-22 Straight Front Metal Shell Connectors can be soldered using wave or equivalent soldering techniques. The temperatures and exposure time shall be within the ranges specified in Figure 10.

NOTE Manual 402-40 provides some guidelines for establishing soldering practices. Refer to Paragraph 2.4, Manuals.



SOLDERING PROCESS	TEMPERATURE		TIME (At Max Temp)
	CELSIUS	FAHRENHEIT	
WAVE SOLDERING	265° ±5° ⚡	509° ±9° ⚡	10 ±.5 Seconds

⚡ Wave Temperature

Figure 10

C. Cleaning

After soldering, removal of fluxes, residues, and activators is necessary. Consult with the supplier of the solder and flux for recommended cleaning solvents. The following is a listing of common cleaning solvents that will not affect the connectors for the time and temperature specified. See Figure 11.

Cleaners must be free of dissolved flux and other contaminants. We recommend cleaning with the pc board on its edge. If using an aqueous cleaner, we recommend standard equipment such as a soak-tank or an automatic in-line machine.

DANGER Consideration must be given to toxicity and other safety requirements recommended by the solvent manufacturer. Refer to the manufacturer's Material Safety Data Sheet (MSDS) for characteristics and handling of cleaners. Trichloroethylene and Methylene Chloride can be used with no harmful affect to the connectors; however Tyco Electronics does not recommend them because of the harmful occupational and environmental effects. Both are carcinogenic (cancer-causing) and Trichloroethylene is harmful to the earth's ozone layer.

NOTE If you have a particular solvent that is not listed, contact the Tooling Assistance Center or Product Information number at the bottom of page 1.



CLEANER		TIME (Minutes)	TEMPERATURE (Maximum)
NAME	TYPE		
ALPHA 2110	Aqueous	1	132°C [270°F]
BIOACT EC-7	Solvent	5	100°C [212°F]
Butyl CARBITOL	Solvent	1	Ambient Room
Isopropyl Alcohol	Solvent	5	100°C [212°F]
KESTER 5778	Aqueous	5	100°C [212°F]
KESTER 5779	Aqueous	5	100°C [212°F]
LONCOTERGE 520	Aqueous	5	100°C [212°F]
LONCOTERGE 530	Aqueous	5	100°C [212°F]
Terpene Solvent	Solvent	5	100°C [212°F]

Figure 11

D. Drying

When drying cleaned assemblies and printed circuit boards, make certain that temperature limitations are not exceeded: -55° to 105°C [-67° to 221°F]. Excessive temperatures may cause housing degradation.

3.15. Checking Installed Connector

The AMPLIMITE HD-22 Straight Front Metal Shell Connectors must be seated on the pc board to the dimensions shown in Figure 12.

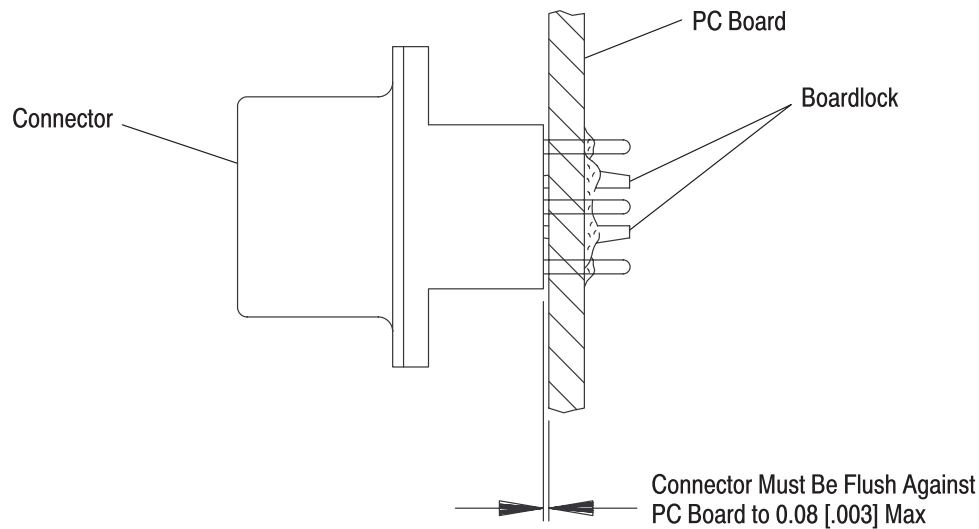

Figure 12

3.16. Repair/Removal

If the connector should become damaged, it must be replaced. The connector may be removed from the pc board by normal desoldering methods and replaced with a new connector.

CAUTION

When repairing or replacing AMPLIMITE HD-22 Straight Front Metal Shell Connectors, be careful not to damage other pc board components during the desoldering process.

4. QUALIFICATIONS

AMPLIMITE HD-22 Straight Front Metal Shell Connectors are Recognized by Underwriters Laboratories Inc. (UL) under File Number E-28476 and Certified by the CSA International under File Number LR-7189.

5. TOOLING

No tooling is required for the placement of these connectors onto the pc board.

6. VISUAL AID

Figure 13 shows a typical application of AMPLIMITE HD-22 Straight Front Metal Shell Connectors. This illustration should be used by production personnel to ensure a correctly applied product. Applications which DO NOT appear correct should be inspected using the information in the preceding pages of this specification and in the instructional material shipped with the product or tooling.

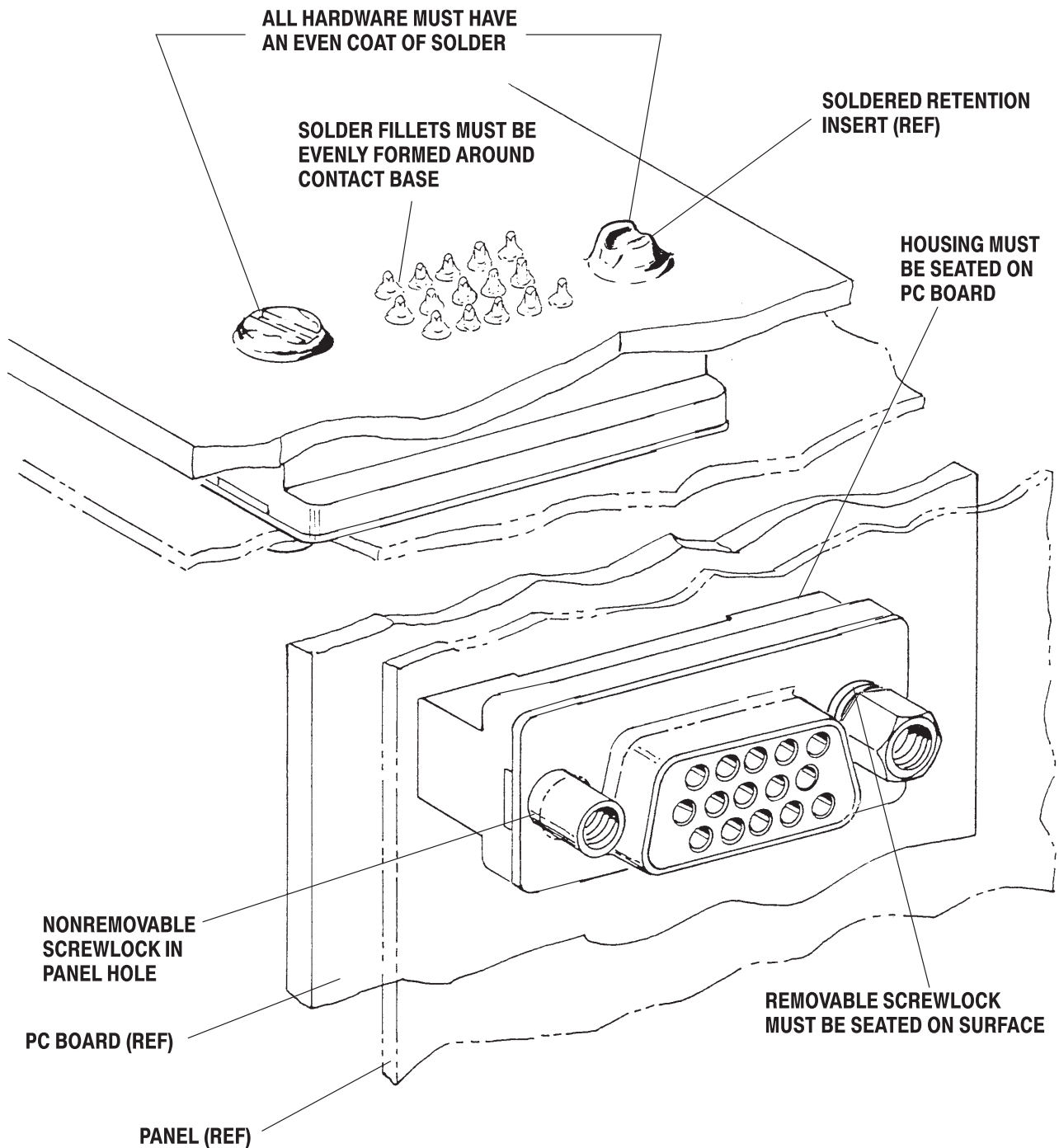

FIGURE 13. VISUAL AID