

THIS DRAWING IS UNPUBLISHED. RELEASED FOR PUBLICATION
 © COPYRIGHT BY TYCO ELECTRONICS CORPORATION. ALL RIGHTS RESERVED.

LOC	DIST	REVISIONS			
P	LTR	DESCRIPTION	DATE	DWN	APVD
DW	—	A	RELEASED	17APR07	HH WK
		B	ECR-07-030526, REVISED	18DEC07	SH WK

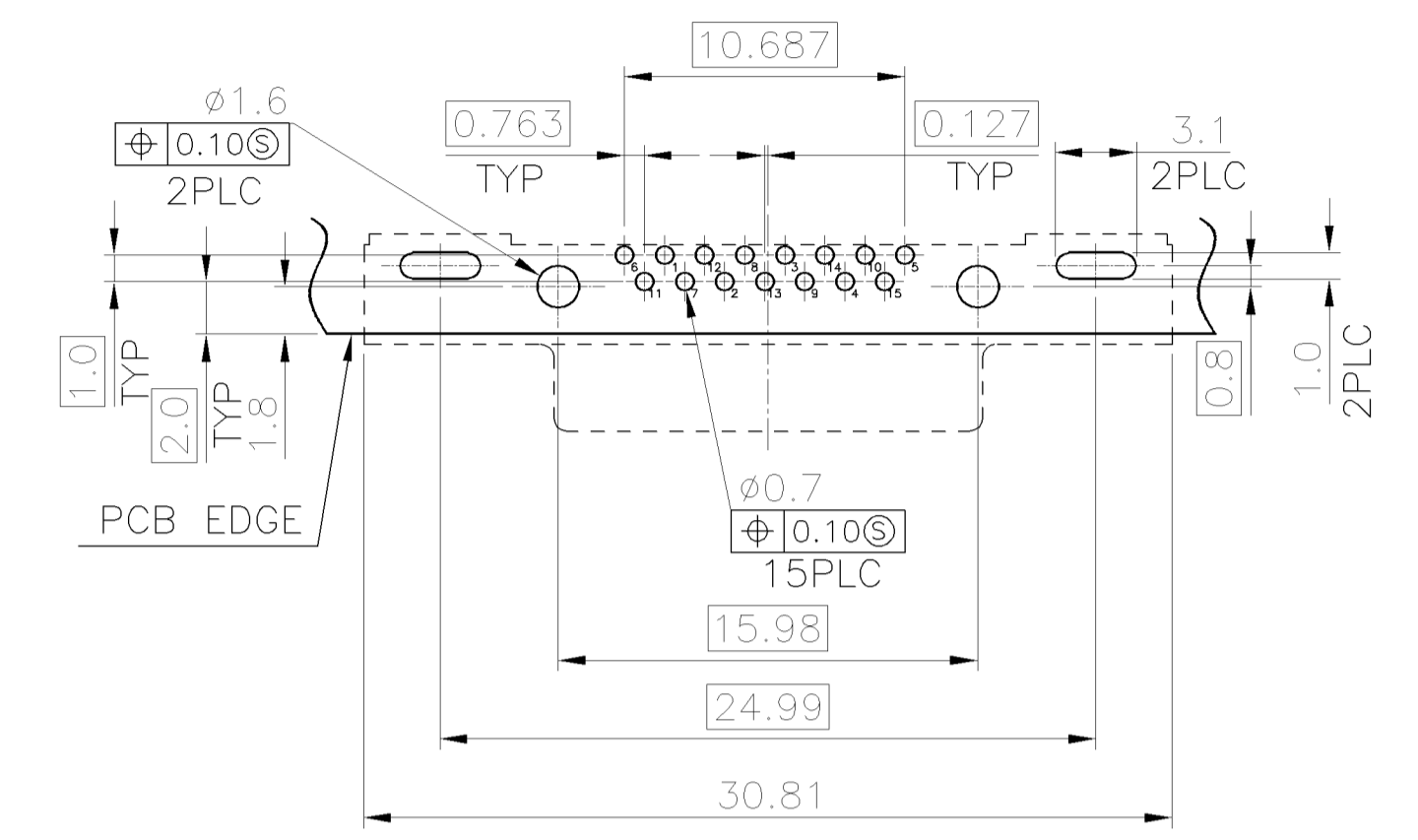
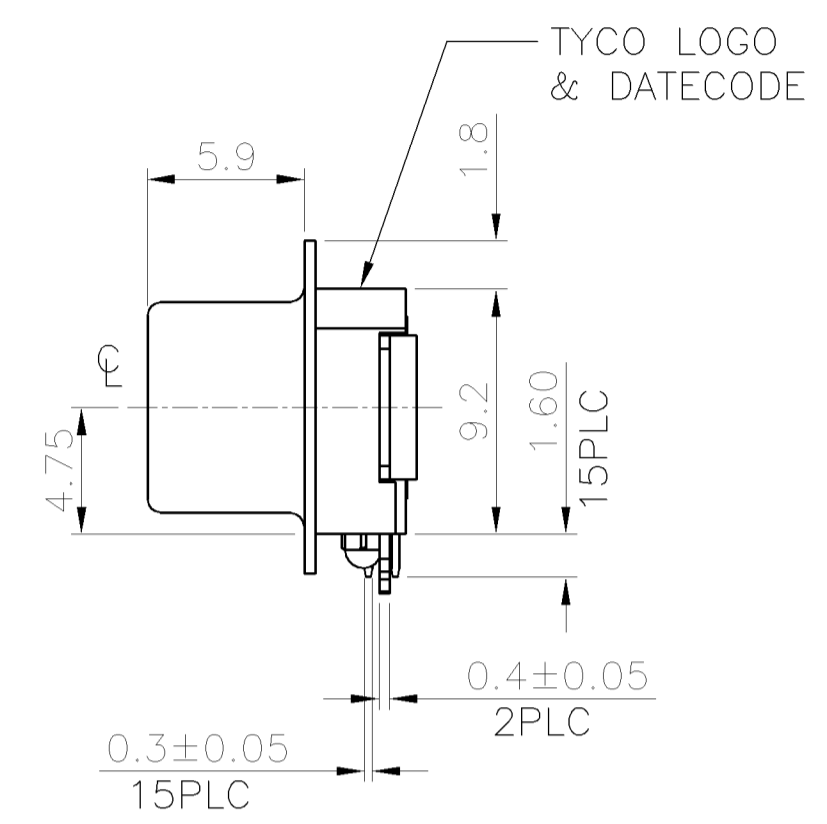
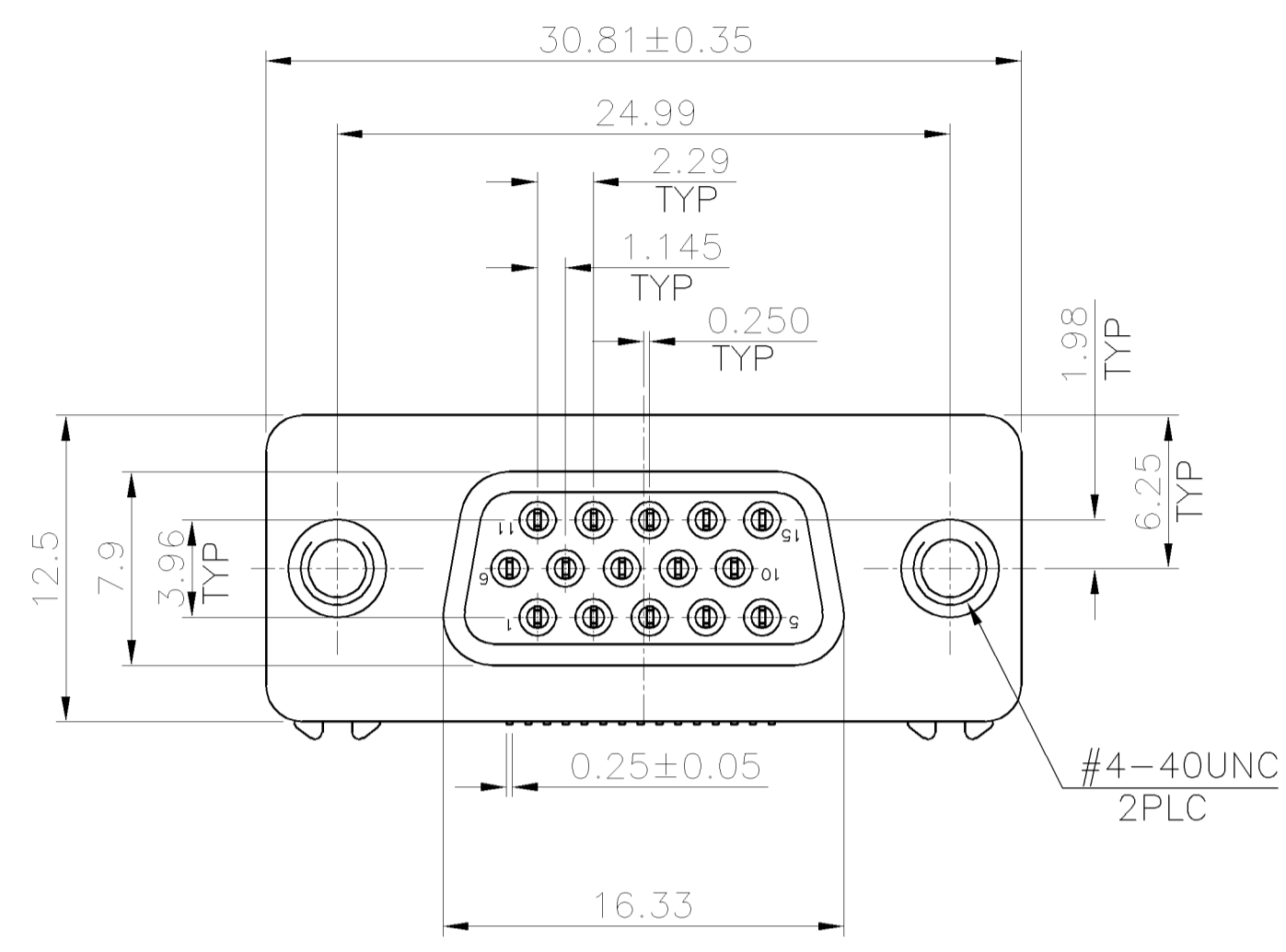

RECOMMENDED P.C.B LAYOUT
 TOLERANCE: ±0.05

NOTES:

- MATERIAL:
 HOUSING: PA9T WITH 33% GF, UL 94V-0, COLOR: BLUE.
 CAP: PA6T WITH 30% GF, UL 94V-0, COLOR: BLACK.
 CONTACTS: PHOSPHOR BRONZE.
 BOARDLOCKS: BRASS.
 SHELL: SPCC.
 RIVET: BRASS.
- FINISH:
 CONTACTS: 0.0254um[1u"] MIN. GOLD PLATED ON CONTACT AREA, 2.54um[100u"] MIN. MATTE-TIN PLATED ON SOLDERTAIL, 1.27um[50u"] MIN. NICKEL UNDERPLATED OVER ALL.
 BOARDLOCKS: 2.54um[100u"] MIN. MATTE-TIN PLATED, 1.27um[50u"] MIN. NICKEL UNDERPLATED OVER ALL.
 SHELL: 2.54um[100u"] MIN. NICKEL PLATED.
 RIVET: 2.54um[100u"] MIN. NICKEL PLATED.
- RECOMMENDED PCB THICKNESS: 1.2mm.
- REFLOW SOLDER CAPABLE TO 260°C PER TE TEST SPEC. 109-201, CONDITION B.

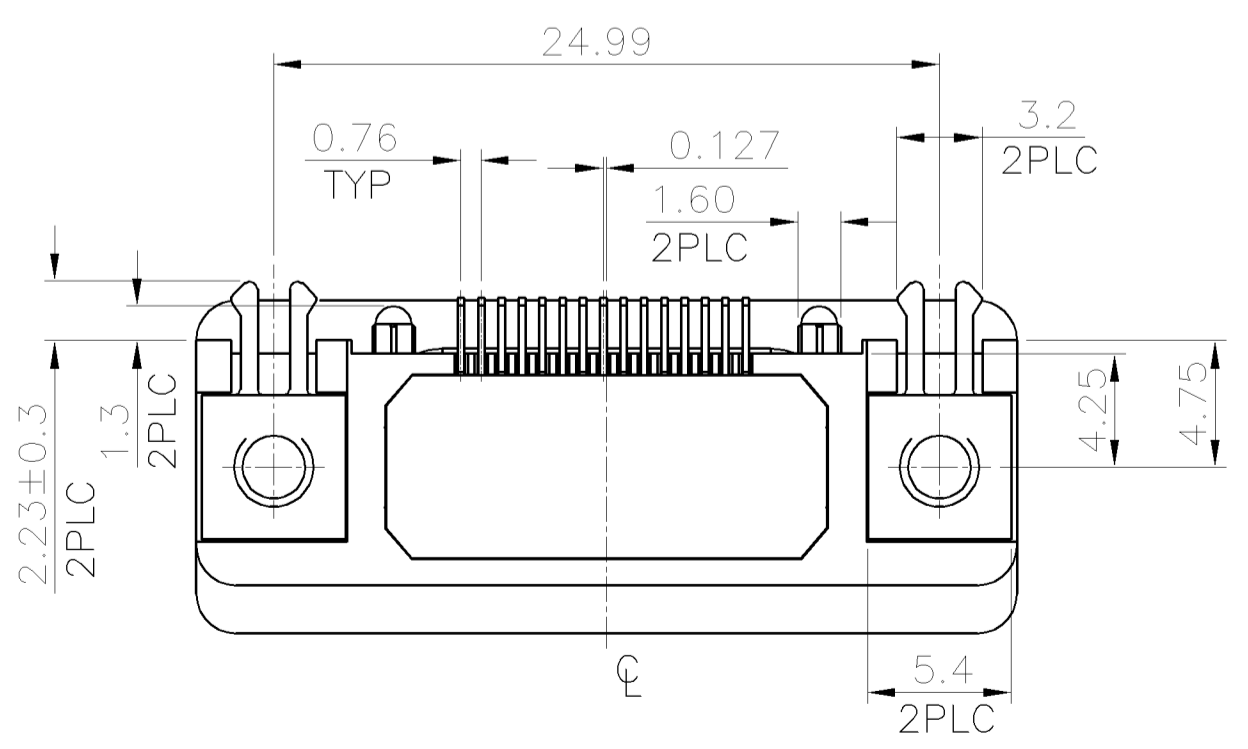
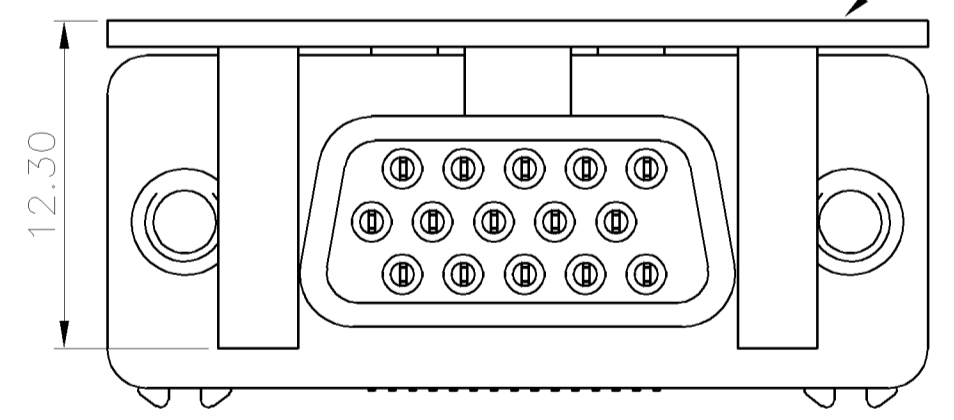
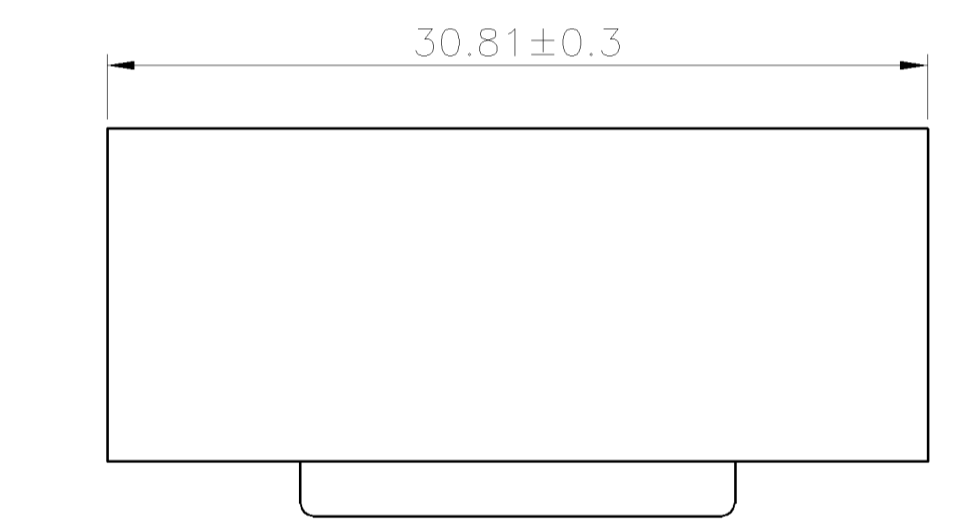
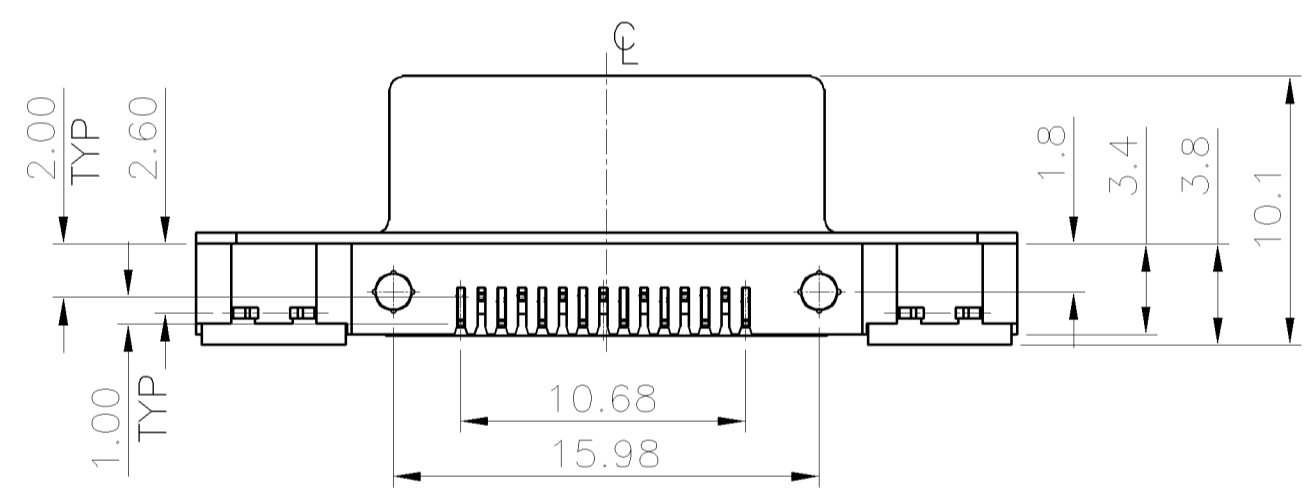

1775323-1
 PART NUMBER

THIS DRAWING IS A CONTROLLED DOCUMENT.		DWN S. HOU 18DEC2007	Tyco Electronics Corporation Typei, Taiwan		
DIMENSIONS: MM		CHK W. KODAMA 18DEC2007	NAME		
TOLERANCES UNLESS OTHERWISE SPECIFIED:		APVD W. KODAMA 18DEC2007	D-SUB 15 POS, R/A, RCPT ULTRA SLIM, DIP CONNECTOR		
0 PLC ± -		PRODUCT SPEC 108-57584	SIZE	CAGE CODE	DRAWING NO
1 PLC ± 0.30		QUALIFICATION TEST REPORT 501-57680	A300779		RESTRICTED TO
2 PLC ± 0.25		WEIGHT 4.2 GRAMS	C=1775323		—
3 PLC ± -		CUSTOMER DRAWING	SCALE	SHEET 1 OF 2	REV B
4 PLC ± -			—		
ANGLES ± 3°					
FINISH SEE NOTE					

THIS DRAWING IS UNPUBLISHED. RELEASED FOR PUBLICATION
 © COPYRIGHT BY TYCO ELECTRONICS CORPORATION. ALL RIGHTS RESERVED.

LOC	DIST	REVISIONS					
DW	-	P	LTR	DESCRIPTION	DATE	DWN	APVD
				SEE SHEET 1.			

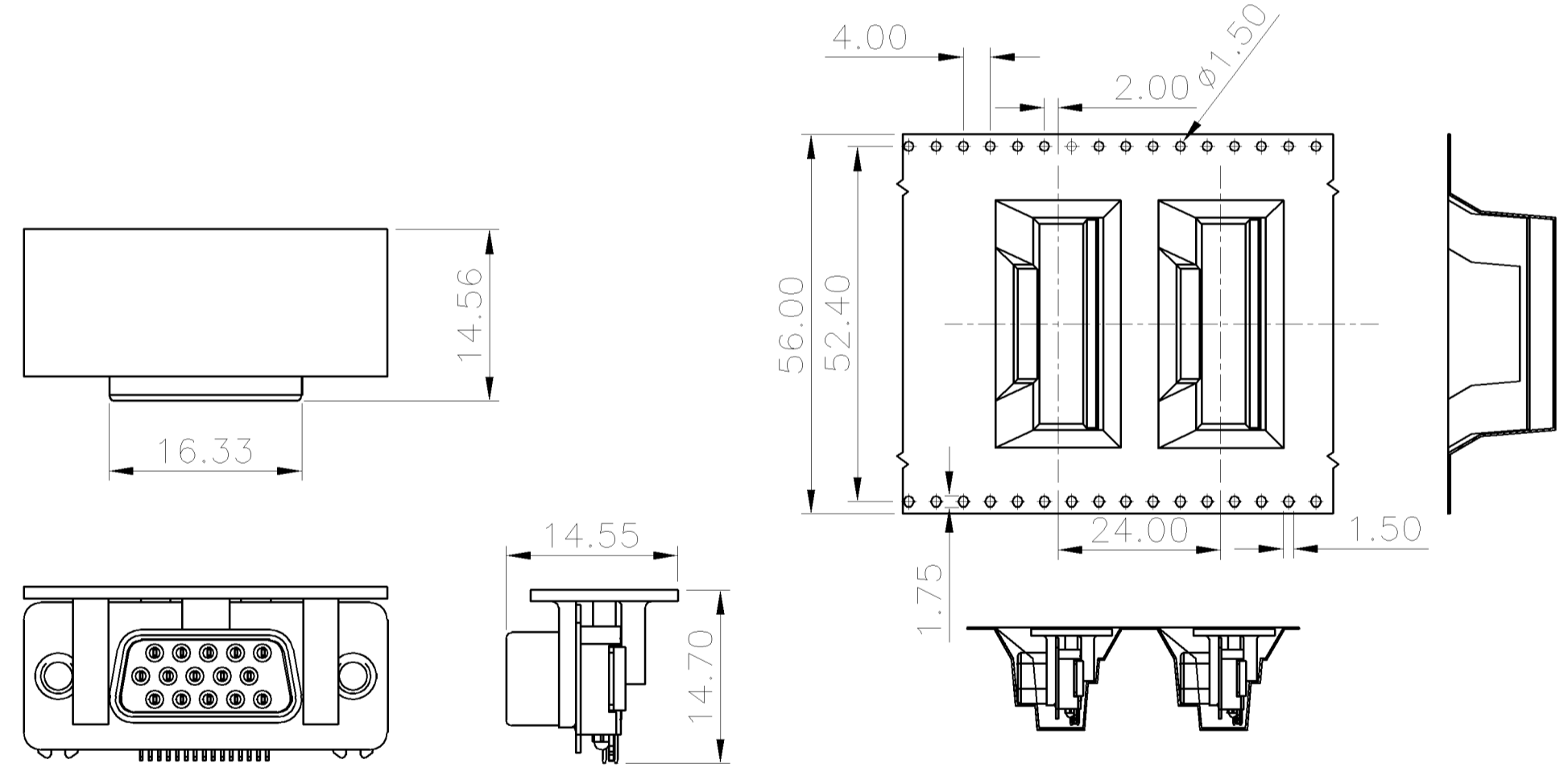
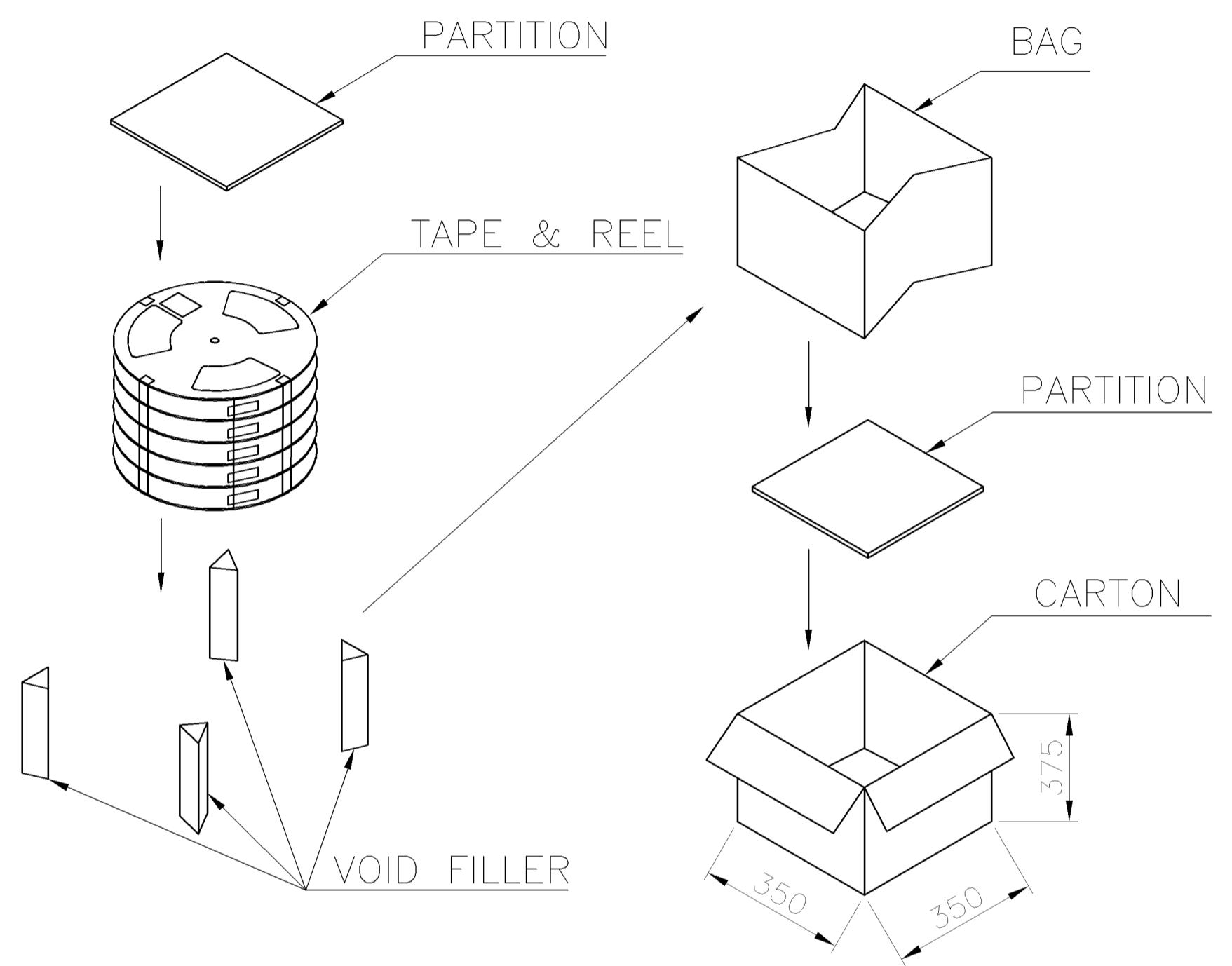
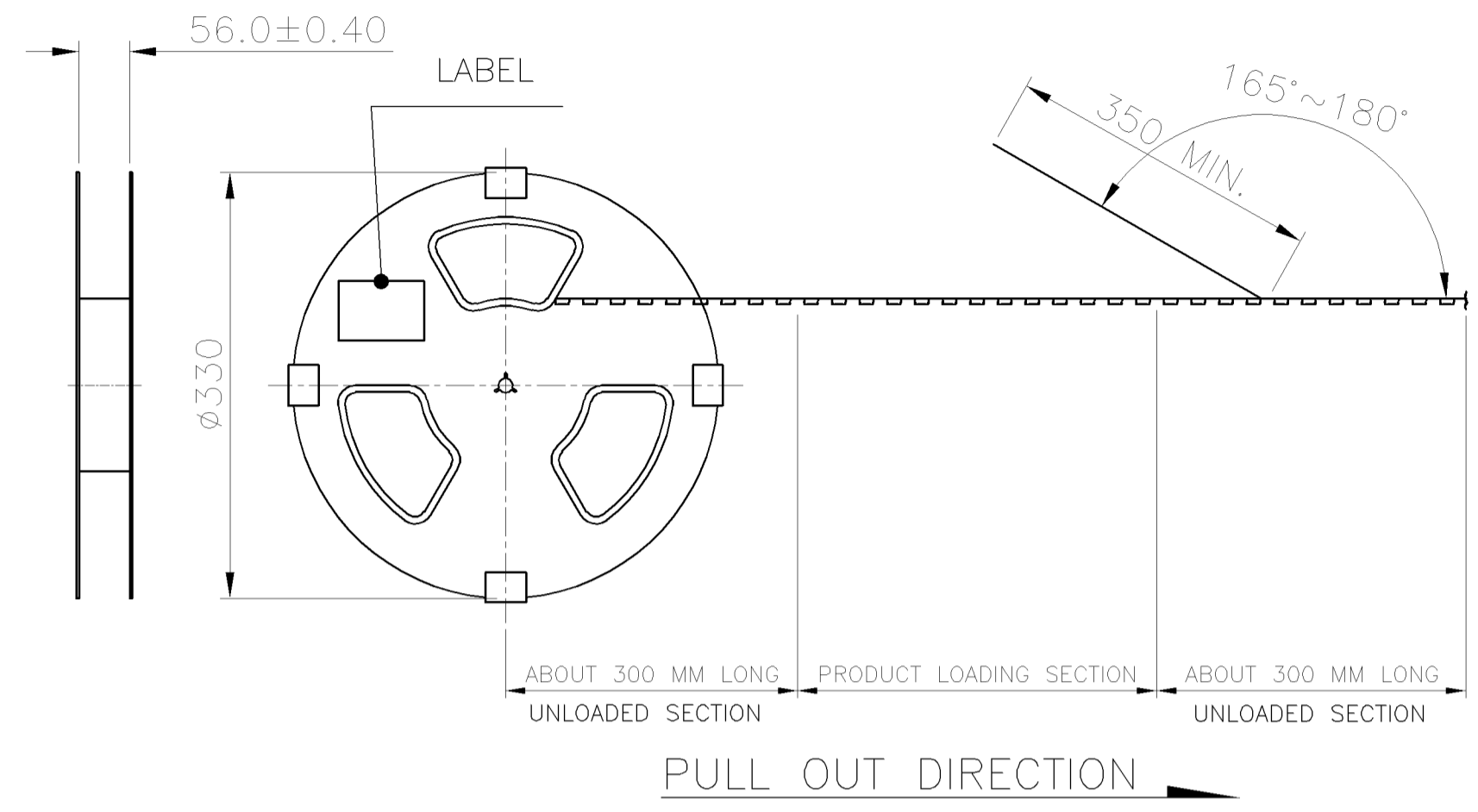

900	6	150	5.8	4.7
QUANTITY (PCS)	REELS/CARTON	PCS/TAPE	G/W (Kg)	N/W (Kg)

THIS DRAWING IS A CONTROLLED DOCUMENT.		DWN S. HOU 18DEC2007	Tyco Electronics Corporation Taipei, Taiwan	
DIMENSIONS: MM		CHK W. KODAMA 18DEC2007	NAME	
TOLERANCES UNLESS OTHERWISE SPECIFIED:		APVD W. KODAMA 18DEC2007	D-SUB 15 POS, R/A, RCPT ULTRA SLIM, DIP CONNECTOR	
MATERIAL		PRODUCT SPEC	SIZE A3	CAGE CODE 00779
FINISH		APPLICATION SPEC	DRAWING NO. C=1775323	RESTRICTED TO
		WEIGHT -	SCALE - SHEET 2 OF 2 REV B	
		CUSTOMER DRAWING		