



All numerical values are in metric units [with U.S. customary units in brackets]. Dimensions are in millimeters [and inches]. Unless otherwise specified, dimensions have a tolerance of  $\pm 0.13$  [ $\pm .005$ ] and angles have a tolerance of  $\pm 2^\circ$ . Figures and illustrations are for identification only and are not drawn to scale.

**1. INTRODUCTION**

This specification covers the requirements for application of AMPLIMITE HDE-20 (IDC) Insulation Displacement Connectors. These connectors are available in all-plastic or metal shell with pre-loaded insulation displacements contacts, pins in plug connectors and sockets in receptacle connectors with 2.74 mm [.108 in.] centerline spacing.

Specific wire and insulation ranges for these contacts are covered in this specification and are 30-20 AWG solid or seven (7) strand discrete wire, jacketed cable, and round conductor flat cable with standard PVC insulation with a maximum diameter of 1.52 mm [.060 in.] and a maximum thickness of 0.38 mm [.015 in.]. Insulation material other than standard PVC should be submitted to Tyco Electronics Engineering for evaluation. Refer to the Product Information number at the bottom of this page.

Each contact features two locking lances which secure the contact in the contact cavity. The contacts must be terminated within the connector using the insulation displacement technique where a discrete wire is inserted into the slotted wire barrel to form an electrical connection. During termination, the insulation support barrel is formed around the wire insulation for strain relief. The number code stamped on the inside of the insulation support barrel corresponds to the wire size range that can be terminated to the contact. These requirements are applicable to hand, bench, and semi-automatic machine application tooling.

When corresponding with Tyco Electronics Personnel, use the terminology provided in this specification to facilitate your inquiries for information. Basic terms and features of this product are provided in Figure 1.

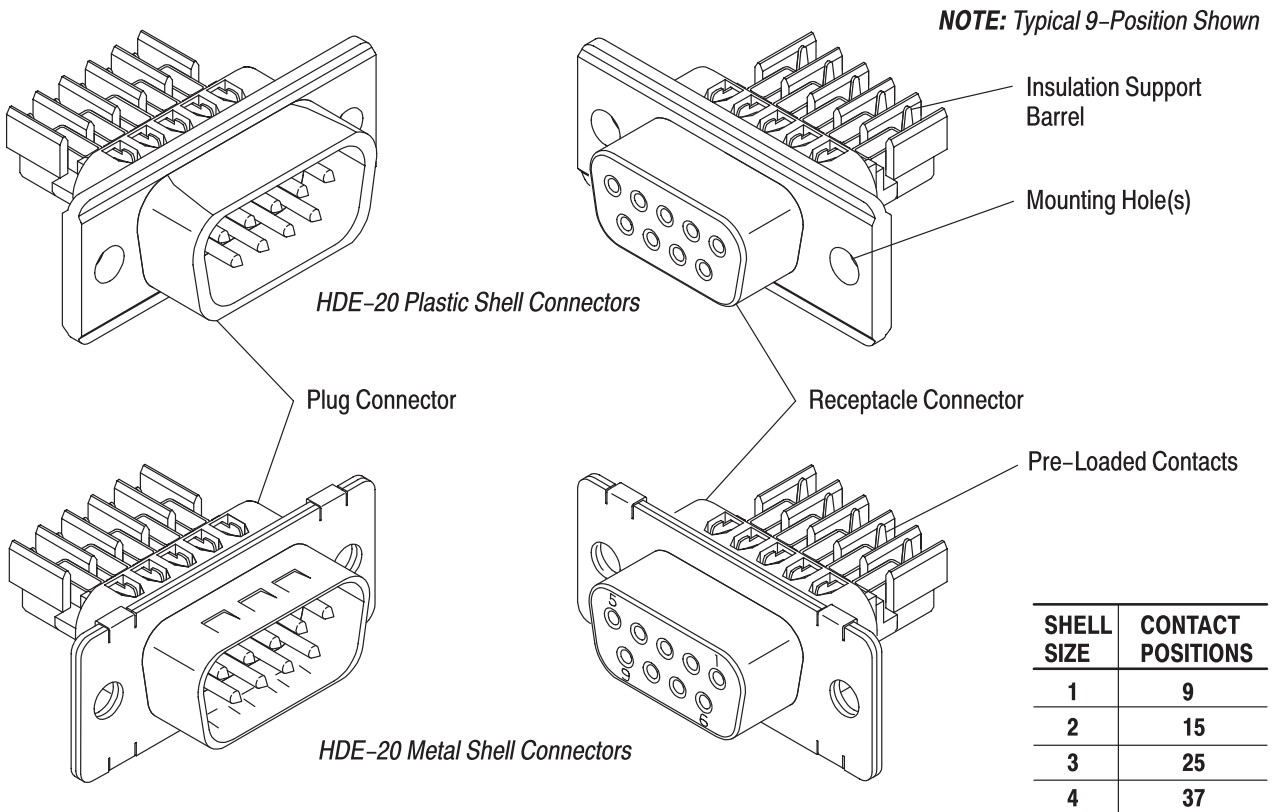
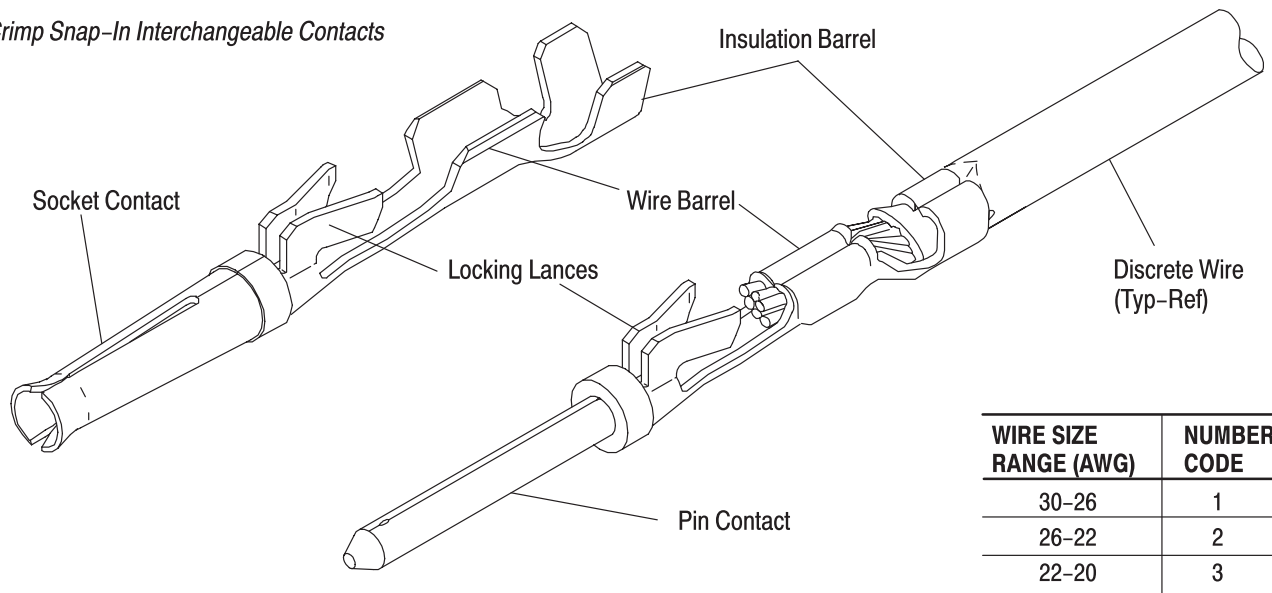

Figure 1 (cont'd)

*Crimp Snap-In Interchangeable Contacts*



WIRE SIZE RANGE (AWG)	NUMBER CODE
30-26	1
26-22	2
22-20	3

Figure 1 (end)

**2. REFERENCE MATERIAL**

**2.1. Revision Summary**

This paragraph is reserved for a revision summary covering the most recent additions and changes made to this specification which include the following:

- Updated document to corporate requirements
- Complete re-work of document
- Added new artwork to all figures
- Added new text and format throughout document
- Deleted part number tables
- Added new tooling references

**2.2. Customer Assistance**

Reference Base Product Part Numbers 745201, 745203 (plastic shell connectors), 745491, 745492 (metal shell connectors), and Product Codes 4944 and 4975 are representative numbers of AMPLIMITE HDE-20 IDC Connectors. Use of these numbers will identify the product line and expedite your inquiries through a service network established to help you obtain product and tooling information. Such information can be obtained through a local Tyco Electronics Representative or, after purchase, by calling the Tooling Assistance Center or the Product Information number at the bottom of page 1.

**2.3. Drawings**

Customer Drawings for each product part number are available from the service network. The information contained in Customer Drawings takes priority if there is a conflict with this specification or with any technical documentation supplied by Tyco Electronics.

**2.4. Specifications**

Product Specifications (108-series) provides product performance and test information. Documents available which pertain to this product are:

<u>Document Number</u>	<u>Document Title</u>
108-40011	AMPLIMITE HDE-20 Connector
108-40030	AMPLIMITE Connector Shielding Hardware
114-40003	AMPLIMITE HDE-20 Contacts
114-40008	AMPLIMITE HDE-20 Shielding Hardware and Enclosure Kits

**2.5. Instructional Material**

The following list includes available instruction sheets (408-series) that provide assembly procedures for product, operation, maintenance and repair of tooling, and customer manuals (409-series) that provides setup, operation, and maintenance of machines.

<u>Document Number</u>	<u>Document Title</u>
408-6574	Ribbon Cable Cutting Hand Tool 91220-1
408-6621	AMPLIMITE HDE-20 All Plastic Connectors
408-6631	Extraction/Insertion Tool 91232-1
408-6645	AMPLIMITE HDE-20 Metal Shell Connectors
408-6789	Pistol Grip Pneumatic Handle Assembly 58075-1
408-6790	Pistol Grip Manual Handle Assembly 58074-1
408-7424	Checking Terminal Crimp Height or Gaging Die Closure
408-7837	Female Screwlock Kits and Male Screw Retainer Kits
408-9393	Pneumatic Power Bench Assembly 58338-1
408-9414	Terminating Head 58063-2 for AMPLIMITE HDE-20 Connectors
409-5746	Electric Power Unit No. 931800-1
409-5839	CHAMPOMATOR* 2.5 Bench Terminating Machines

**3. REQUIREMENTS**

**3.1. Safety**

Do not stack product shipping containers so high that the containers buckle or deform.

**3.2. Storage**

**A. Ultraviolet Light**

Prolonged exposure to ultraviolet light may deteriorate the chemical composition used in the connector material.

**B. Shelf Life**

The connectors should remain in the shipping containers until ready for use to prevent deformation. The components should be used on a first in, first out basis to avoid storage contamination that could adversely affect signal transmissions and performance.

**C. Chemical Exposure**

Do not store connectors near any chemicals listed below, as they may cause stress corrosion cracking in the contacts.

Alkalies	Ammonia	Citrates	Phosphates	Citrates	Sulfur Compounds
Amines	Carbonates	Nitrites	Sulfur	Nitrites	Tartrates

**3.3. Material**

The housings are made from 94V-0 rated thermoplastic, and the contacts are phosphor bronze with gold flash on the mating end, tin-lead on the termination end, with the entire contact underplated with nickel.

**3.4. Wire Selection and Preparation**

**A. Selection**

The contacts accept solid or 7-strand discrete wire, jacketed cable, or flat ribbon cable with round wires.

Wires must have a wire size range of 30-20 AWG with a maximum insulation diameter range of 1.52 mm [.060 in.] and maximum insulation thickness of 0.38 mm [.015 in.]. The wire insulation must be made of polyvinylchloride (PVC).

**B. Preparation**

For discrete wire application, no preparation is required. For jacketed cable, proper strip length is necessary to properly insert individual wires into the contacts. Strip length is given in Figure 2. Ribbon cable must be cut perpendicular to the length of the cable, then individual wires separated to the dimensions given in Figure 2.

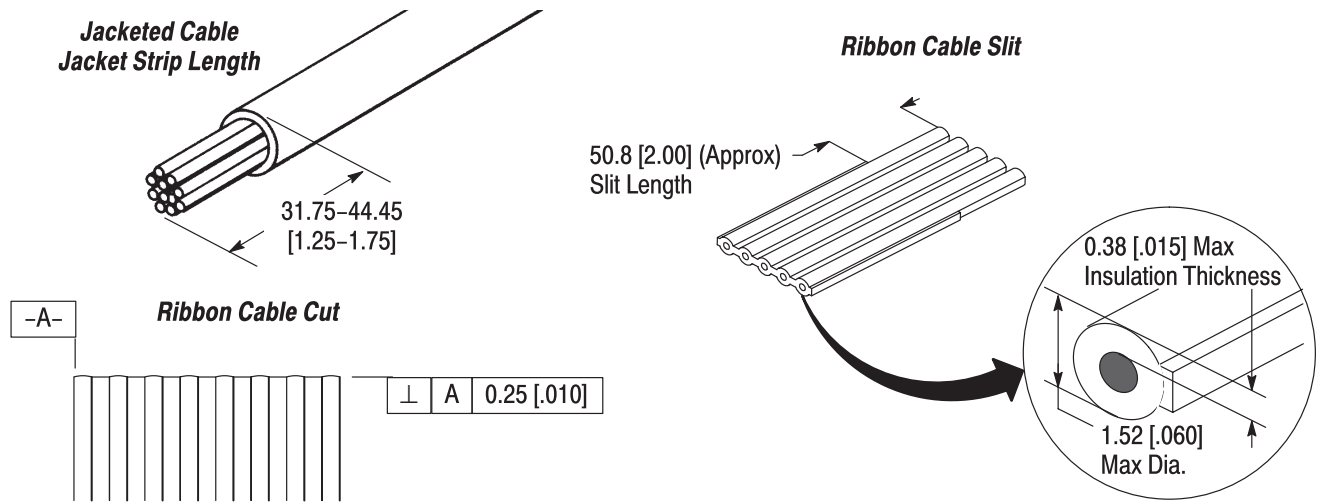

WIRE SIZE (AWG)	CABLE PREPARATION LENGTH		
	DISCRETE WIRE	JACKETED CABLE JACKET STRIP LENGTH	RIBBON CABLE SLIT LENGTH
30-20	No Preparation Required	31.75-44.45 mm [1.250-1.750 in.]	50.8 mm [2.00 in.]

Figure 2



Care shall be taken not to cut the individual conductor insulation during the jacket stripping operation.

**C. Round Conductor Flat Cable**

The ends of the cable shall be cut perpendicular to the edge of the cable within the limits shown in Figure 2. Cable shall be slit into individual wires as indicated in Figure 2. Refer to Section 5, TOOLING.

**3.5. Termination Requirements**



Refer to Section 5, TOOLING for application tooling available to terminate the AMPLIMITE HDE-20 IDC Connectors.

The wire must be terminated to the contacts according to instructions packaged with the applicable tooling. The terminated contact must meet the following requirements.

**A. Damage**

There shall be no evidence of damage or deformation to any part of the contacts or connectors. Damaged contacts or connectors should not be used.

**B. Wire**

The wire size must match the contact number code as provided in Figure 3. The wire insulation of each wire (excluding sections seated in the wire slots) and the cable jacket must not be cut or broken.

**C. Locking Lances**

The locking lances must not be deformed.

**D. Insulation Support Barrel**

The insulation support barrel of each contact must be fully wrapped around the wire insulation just enough to prevent the wire from separating from the wire slots. It is acceptable for the insulation barrel to pierce or wrap inside the wire insulation.

**E. Wire Location**

Each wire must be straight and fully seated between the slots of the wire barrel with the centerline of the wire located within the dimension given in Figure 3.

The end of each wire must extend beyond the end of the wire barrel no less than the dimension given in Figure 3.

**Termination Requirements**

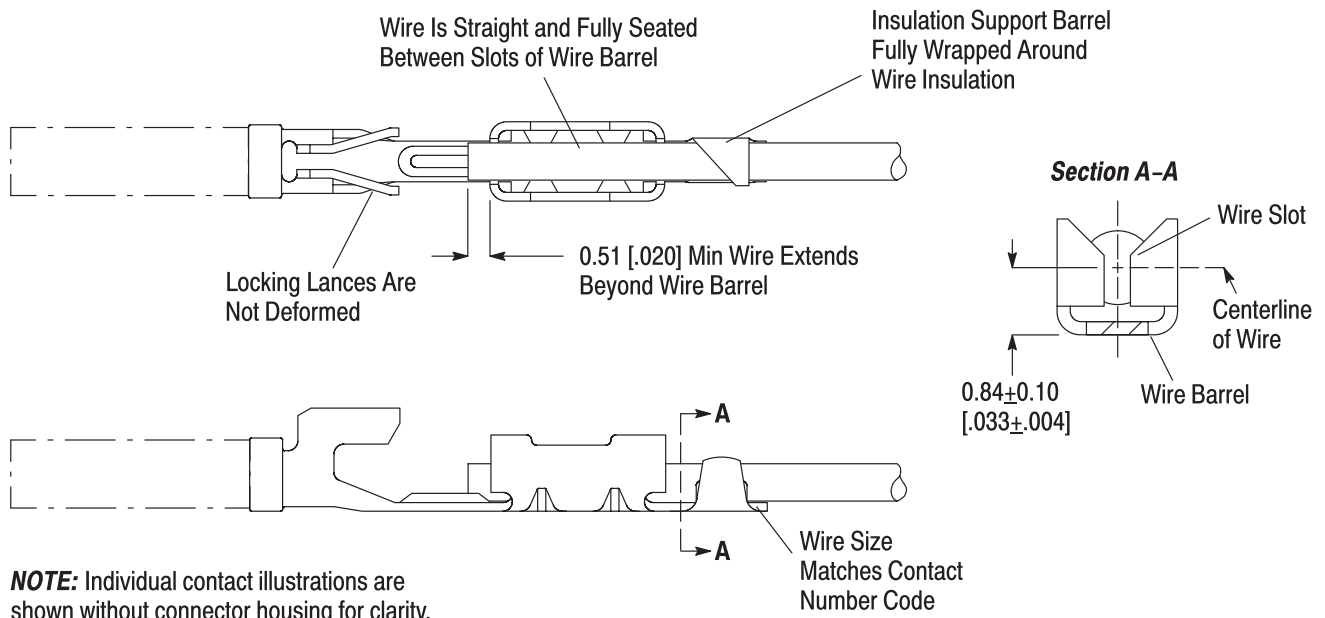

Figure 3

**3.6. Panel Cutout**

Recommended panel cutout dimensions for AMPLIMITE HDE-20 IDC Connectors is shown in Figure 4. The panel thickness shall be compatible with the mating dimensions shown in Figure 5.

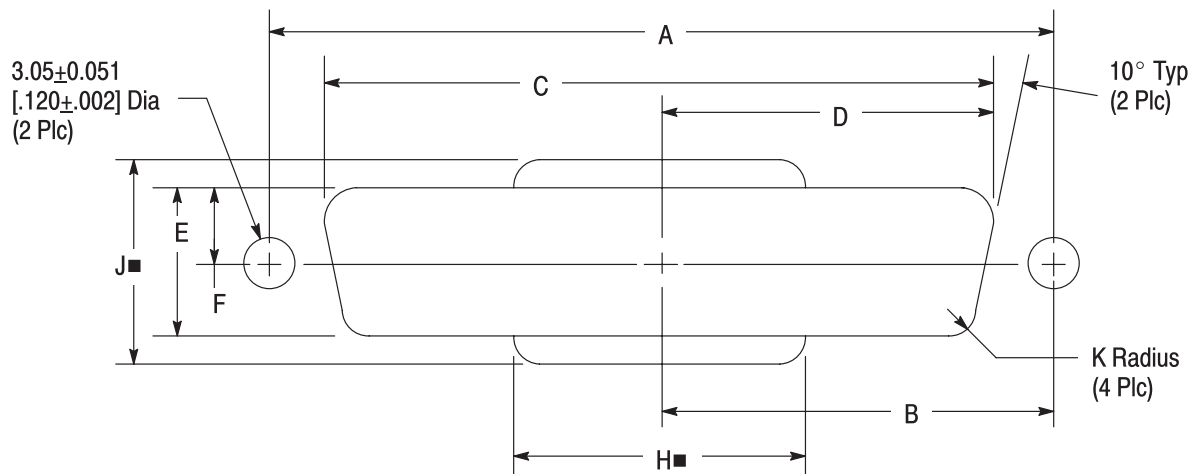

Figure 4 (cont'd)

SHELL SIZE (POSN)	MOUNTING METHOD Front/Rear Panel	PANEL MOUNT DIMENSIONS								
		A	B	C	D	E	F	H*	J*	K
1 (9)	Front	24.99 [.984]	12.50 [.492]	22.20 [.874]	11.10 [.437]	13.03 [.513]	6.53 [.257]	---	---	2.11 [.083]
	Rear	24.99 [.984]	12.50 [.492]	20.47 [.806]	10.24 [.403]	11.41 [.449]	5.72 [.225]	13.97 [.550]	19.05 [.750]	3.35 [.132]
2 (15)	Front	33.33 [1.312]	16.66 [.656]	30.53 [1.202]	15.27 [.601]	13.03 [.513]	6.53 [.257]	---	---	2.11 [.083]
	Rear	33.33 [1.312]	16.66 [.656]	28.80 [1.134]	14.40 [.567]	11.41 [.449]	5.72 [.225]	18.54 [.730]	19.05 [.750]	3.35 [.132]
3 (25)	Front	47.04 [1.852]	23.52 [.926]	44.27 [1.743]	22.15 [.872]	13.03 [.513]	6.53 [.257]	---	---	2.11 [.083]
	Rear	47.04 [1.852]	23.52 [.926]	42.52 [1.674]	21.26 [.837]	11.41 [.449]	5.72 [.225]	32.39 [1.275]	19.05 [.750]	3.35 [.132]
4 (37)	Front	63.50 [2.500]	31.75 [1.250]	60.73 [2.391]	30.38 [1.196]	13.03 [.513]	6.53 [.257]	---	---	2.11 [.083]
	Rear	63.50 [2.500]	31.75 [1.250]	59.08 [2.326]	29.54 [1.163]	11.41 [.449]	5.72 [.225]	46.05 [1.920]	16.13 [.750]	3.35 [.132]

■ Panel cutout configuration with H and J dimensions provides clearance for mounting connectors with cable clamps.

Figure 4 (end)

### 3.7. Mating

The mating dimension must be considered when determining the method of mounting to ensure full mating of the connectors. The panel thickness and mounting hole location on the panel must also be considered to avoid interference when the connector is mounted to the panel. The required dimension between mating connector mounting flanges is provided in Figure 5.

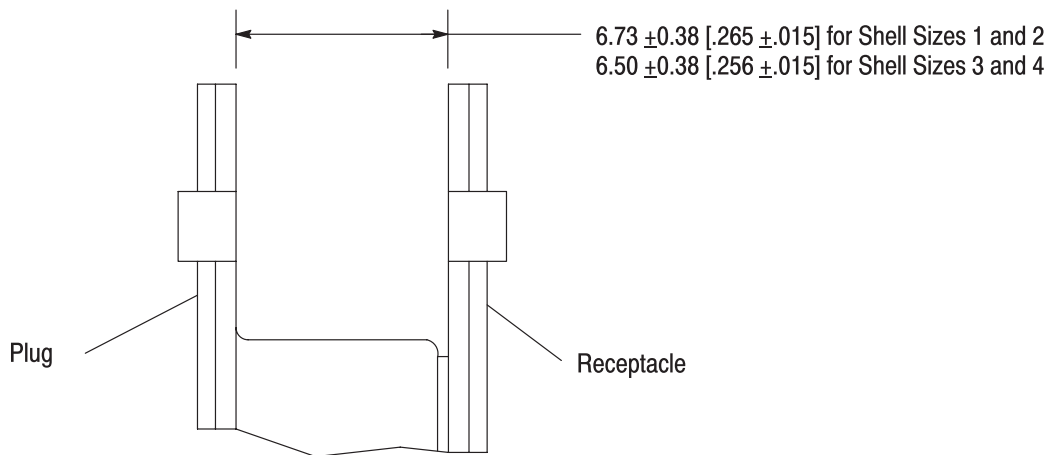

Figure 5

### 3.8. Mounting Hardware

Information related to mounting hardware for the AMPLIMITE HDE-20 IDC Plug and Receptacle Connectors may be found in Instruction Sheets 408-6551, 408-7837, 408-9128, and 408-9130.

#### 4. QUALIFICATION

AMPLIMITE HDE-20 IDC Plug and Receptacle Connectors are Listed by Underwriters Laboratories Inc. (UL) under File E81956 and Certified by CSA International under File LR7189.

#### 5. TOOLING

Tooling part numbers and instructional material packaged with the tooling are shown in Figure 6.

##### 5.1. Cable Preparation Tool

The ribbon cable cutting hand tool makes a perpendicular cut across ribbon cable.



*You may purchase Ribbon Cable Cutting Hand Tool 91220-1 from Tyco Electronics or commercial cable cutting tools are available for slitting the ribbon cable.*

##### 5.2. Contact Removal Tool

The extraction/insertion tool is used to release the contact from the housing without damaging the connector. Use Extraction/Insertion Tool 91232-1.

##### 5.3. Terminating Head

This head is designed to terminate the insulated conductor of each wire to the contact wire slots of the connector using the insulation displacement technique and form the insulation barrel around the wire insulation. The head must be installed onto a tool or power unit.

##### 5.4. Terminating Tools

###### A. Hand Held Assemblies

The pistol grip handle assemblies provide the necessary force to drive the terminating head to terminate the connectors. The tools are available as manually-operated or pneumatically-powered, both actuated by a trigger. The pneumatic assembly is designed to allow the head to be rotated.

###### B. Bench Mounted Assembly

The power bench assembly provides the necessary force to drive the terminating head to terminate the connectors. This tool is pneumatically-powered and actuated by a foot switch. The tool can be mounted according to operator preference and desired eject direction of the terminated connector.

##### 5.5. Power Unit

This electrically-powered machine provides the necessary action to power the terminating head to terminate the connectors. The machine is foot switch actuated and designed to be bench mounted. The machine provides for medium volume production.

WIRE SIZE (AWG)	TERMINATING HEAD (DOCUMENT)	TOOLING (DOCUMENT)	TOOL DESCRIPTION	TERMINATIONS PER CYCLE (MAX)
30-20	58063-2 (408-9414)	58074-1 (408-6790)	PISTOL GRIP, Manual Handle	1
		58075-1 (408-6789)	PISTOL GRIP, Pneumatic Handle	1
		58338-1 (408-9393)	PNEUMATIC POWER BENCH	1
		931800-1 (409-5746)	ELECTRIC POWER UNIT	1
	None	354786-4 (409-5839)	CHAMPOMATOR, HDE Series (180° Cable Dress)	2

Figure 6 (cont'd)

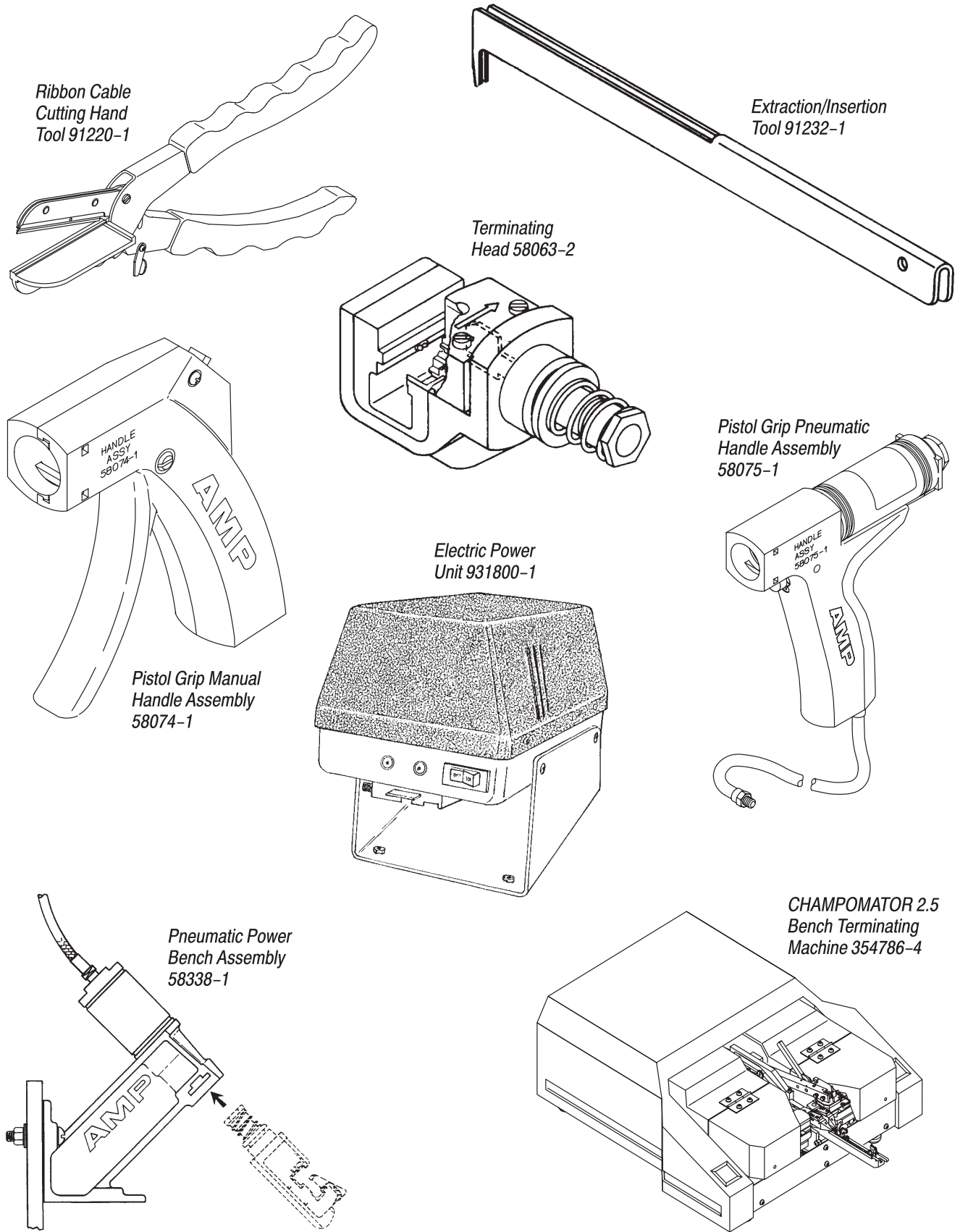
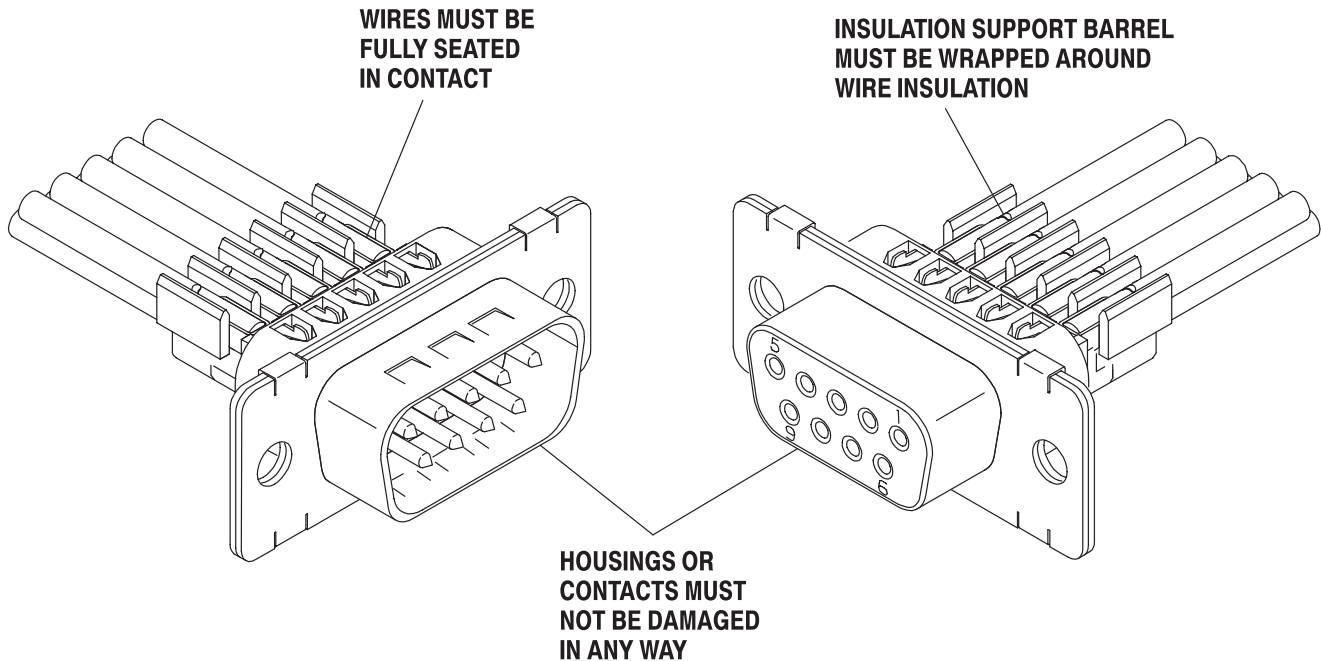

Figure 6 (end)



## 6. VISUAL AID

Figure 7 shows a typical application of AMPLIMITE HDE-20 IDC Connectors. This illustration should be used by production personnel to ensure a correctly applied product. Applications which DO NOT appear correct should be inspected using the information in the preceding pages of this specification and in the instructional material shipped with the product or tooling.



**FIGURE 7. VISUAL AID**