

SHIELDING HARDWARE KITS

CONTACT POSITION	HDE-20 CONNECTOR		HDP-20 CONNECTOR		CONTACT POSITION	HDP-22 CONNECTOR	
	PLUG	RECEPTACLE	PLUG	RECEPTACLE		PLUG	RECEPTACLE
9	747515-[]	747516-[]	747522-1	747523-1	15	748468-1	748634-1
15	747531-[]	747532-[]	747538-1	747539-1	26	748469-1	748635-1
25	747547-[]	747548-[]	747554-1	747555-1	44	748470-1	748636-1
37	747563-[]	747564-[]	747570-1	747571-1	62	748471-1	748637-1
50	—	—	747577-1	747578-1	78	748472-1	748638-1

Figure 1

## 1. INTRODUCTION

This instruction sheet covers assembly procedures for the shielding hardware kits listed in Figure 1. The kits are used to construct an RF/EMI-shielded connector assembly for customer-applied overmolding which requires a plastic injection molding process.

**NOTE** Consult your local Tyco Electronics representative for application specifications relating to these kits.

Read these instructions, and all referenced material, before assembling the kits. Detailed operating procedures are provided in the instructions packaged with the crimping die assemblies and tooling.

**NOTE** Dimensions on this sheet are in metric units [with U.S. customary units in brackets]. Figures are not drawn to scale.

Reasons for reissue of this instruction sheet are provided in Section 6, REVISION SUMMARY.

## 2. DESCRIPTION (Figure 1)

Each kit includes an AMPLIMITE HDE-20, HDP-20, or HDP-22 connector, an inner shield, and an outer shield.

The connector (plug or receptacle) features slots on the rear of the metal shell which are keyed to accept hinge tabs of the corresponding shield.

The metal shields are designed to hinge on the rear of the metal shell of the connector. The two parts of the shield assembly are designed as inner and outer due to their mating characteristics. The inner shield always hinges on the shorter side of the keystone configuration and the outer shield hinges on the longer side. The inner shield locks into the outer shield with a pair of latching tabs.

An appropriate ferrule must be ordered separately. It is crimped by tooling fitted with a die assembly and is used to secure the shield assembly and cable. The larger diameter end of the ferrule fits onto the braid crimp area of the shield assembly, and the smaller diameter end fits over the cable jacket.

CONTACT POSITION		FERRULE■	CABLE DIAMETER RANGE (mm [in.])	CRIMPING DIE ASSEMBLY•	TOOLING•
HDE-20, HDP-20	HDP-22				
9, 15, 25	15, 26, 44	747579-8	4.19-4.83 [.165-.190]	543424-3 (408-9507)	Hand Crimping Tool 543344-1 (408-9315) or 2700-lb Pneumatic Power Unit 312522-3 (409-5843) fitted with Die Holder 58449-1 (408-9721)
			4.83-5.51 [.190-.217]	543424-2 (408-9507)	
			5.51-6.25 [.217-.246]	543424-8 (408-9507)	
		1-747579-0	6.25-7.21 [.246-.284]	543424-1 (408-9507)	
		1-747579-1	7.21-8.23 [.284-.324]	543424-7 (408-9507)	
		1-747579-2	8.23-9.52 [.324-.375]	543424-6 (408-9507)	
		1-747579-4	9.52-11.05 [.375-.435]	543424-5 (408-9507)	
37	62	747580-6	10.16-11.56 [.400-.455]	543424-4 (408-9507)	
37, 50	78	1-747580-0	12.19-14.28 [.480-.562]	58237-1 (408-9242)	
		747580-8	5.84-6.73 [.230-.265]	543425-2 (408-9508)	
		747580-4	8.58-9.78 [.338-.385]	543425-1 (408-9508)	
		747580-5	9.52-10.97 [.375-.432]	58238-1 (408-9243)	
			10.72-12.45 [.422-.490]	58237-2 (408-9242)	

- Must be ordered separately from shielding hardware kit.
- Instruction material shown in parenthesis.

Figure 2

### 3. PREPARATION

The contacts will accept solid or stranded wire with an individual wire size range of 28 through 18 AWG.

Prepare the cable as follows:

1. Obtain the connector and cable of the type and size required for your application. See Figure 2.
2. Slide the appropriate ferrule, smaller diameter end first, onto the cable. See Figure 3.

**CAUTION**  The ferrule **MUST** be placed on the cable before terminating the connector and installing the metal shields. The metal shields cannot be crimped onto the cable without using a ferrule.

3. Strip the jacket to dimension shown in Figure 3. Then fold braid back over cable jacket.

**NOTE**  Braid may be trimmed to 12.7 mm [.50 in.] now, or trimmed after ferrule crimping.

4. Terminate individual wires onto connector contacts.

**NOTE**  For information regarding wire termination of AMPLIMITE HDE-20 connectors, refer to Instruction Sheet 408-6645; for AMPLIMITE HDP-20 connectors, refer to 408-7514; and for AMPLIMITE HDP-22 connectors, refer to 408-9381.

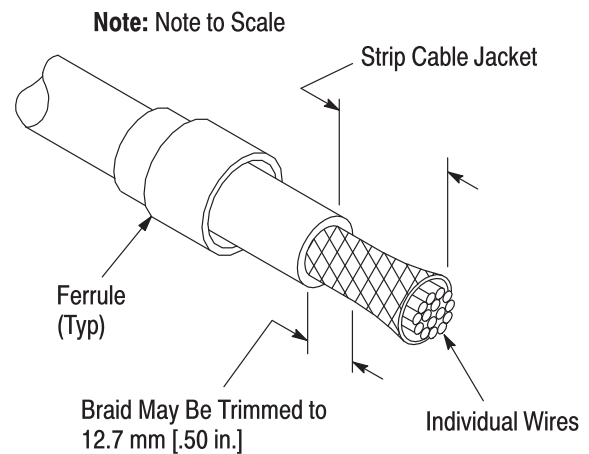

CONTACT POSITION		CABLE JACKET STRIP LENGTH ±1.27 [.050] (mm [in.])
HDE-20, HDP-20	HDP-22	
9, 15, 25	15, 26, 44	33.02 [1.300]
37	62	43.18 [1.700]
50	78	40.64 [1.600]

Figure 3

5. For HDE-20 connectors, obtain 3M<sup>®</sup> Scotch Tape 44 (or equivalent), 9.53 mm [.375 in.] wide. Wrap the tape around the terminated contacts two complete times. See Figure 4.

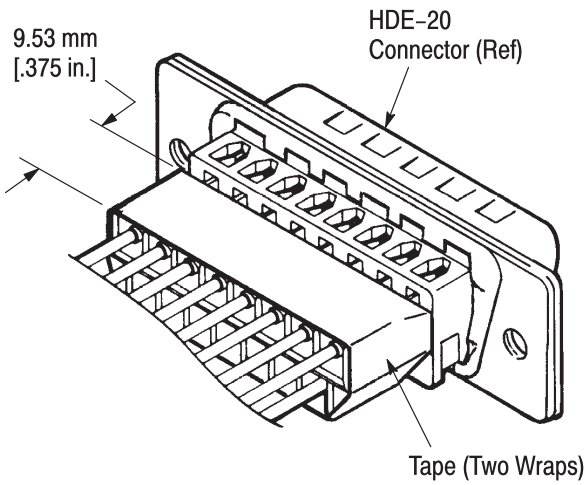
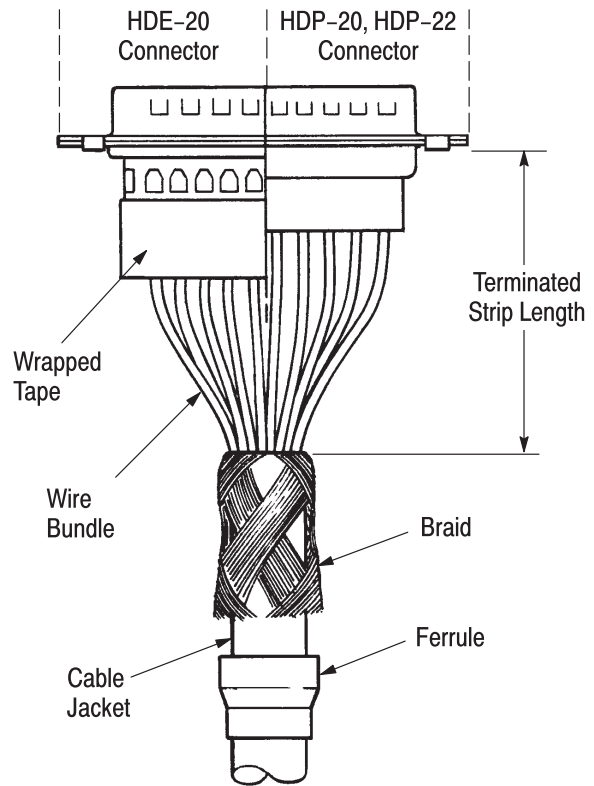

Figure 4



**4. SHIELD ASSEMBLY PROCEDURE**

1. Measure the terminated length of the assembly as shown in Figure 5.



*The length must be as indicated in Figure 5 and must conform to the configuration as shown in the illustration; otherwise, wires may be pinched between the shields when they are closed. The proper length and configuration may be achieved by twisting (and thereby shortening) the wire bundle after termination; however, make certain that no undue stress is placed on the terminated contacts during the procedure. The MAXIMUM amount that the bundle may be twisted to achieve the desired length is 90°.*

2. Insert the hinge tabs of the inner shield into the corresponding slots of the connector and rotate the shield 90° toward the cable. See Figure 6.

3. Insert the hinge tabs of the outer shield into the corresponding slots of the connector. See Figure 6.

4. Make sure that the inner shield is in its final position and close the outer shield until it latches onto the inner shield with the two latching tabs fully engaged. See Figure 7.

CONNECTOR TYPE	CONTACT POSITION	TERMINATED STRIP LENGTH ±1.27 [±.050] (mm [in.])
HDE-20	9, 15, 25	33.02 [1.300]
	37	38.10 [1.500]
HDP-20	9, 15, 25	33.02 [1.300]
	37	40.64 [1.600]
	50	38.10 [1.500]
HDP-22	15, 26, 44	33.02 [1.300]
	62	40.64 [1.600]
	78	38.10 [1.500]

Figure 5



*Take care not to pinch any individual wires between the shields.*

5. Slide the braid over the braid crimp area of the mated shields. See Figure 7.

6. Slide ferrule forward until it is over the braid and butted against the shield assembly.

□ Trademark of Minnesota Mining & Manufacturing Co.

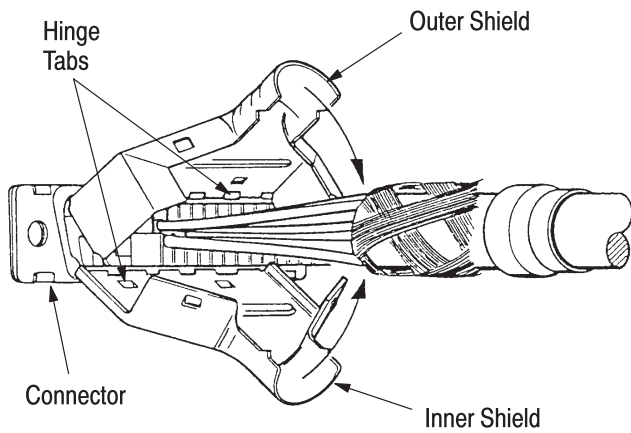

Figure 6

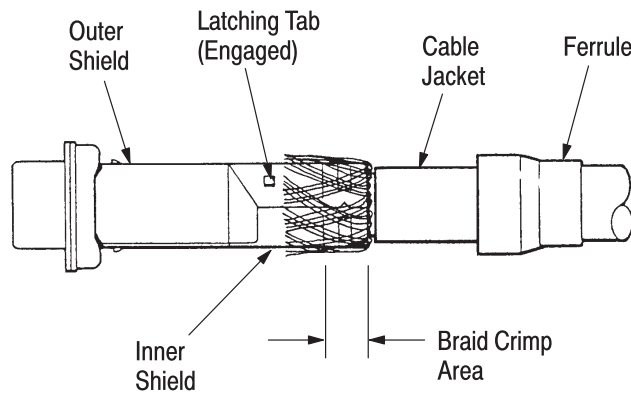

Figure 7

**5. CRIMPING THE FERRULE**

1. Refer to Figure 1 and determine the crimping die assembly and tooling to be used for crimping the ferrule.

2. Crimp the ferrule onto the shield assembly and cable.

3. Examine the terminated assembly according to Figure 8 and, if necessary, trim excess cable braid from the braid crimp area.

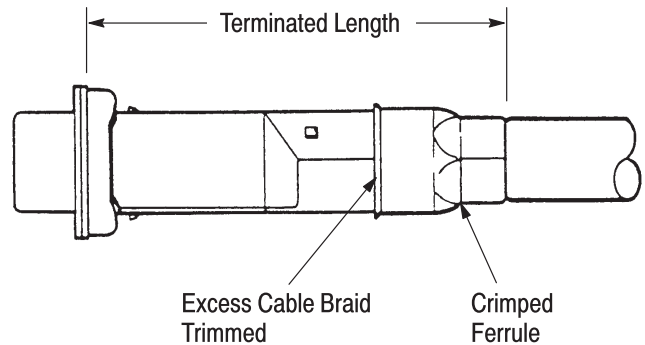

CONNECTOR TYPE	CONTACT POSITION	TERMINATED LENGTH $\pm.635$ [.025] (mm [in.])
HDE-20	9, 15, 25	38.61 [1.520]
	37	47.42 [1.867]
HDP-20	9, 15, 25	38.99 [1.535]
	37	48.06 [1.892]
	50	47.65 [1.876]
HDP-22	15, 26, 44	38.99 [1.535]
	62	48.06 [1.892]
	78	47.65 [1.876]

Figure 8

**6. REVISION SUMMARY**

Revisions to this instruction sheet include:

- Updated to corporate requirements.