

LOC		DIST		REVISIONS			
DF	DO	REV	DATE	BY	CHK	APPV	
L		1	01-04-09	CT	RL		
		REVISED PER ECO-09-012541					

- THIS RECEPTACLE WILL MATE WITH ANY 17C2, SIZE 3 PLUG IN AMPLIMITE SERIES.
- MAXIMUM WIRE INSULATION TO BE USED WITH THIS RECEPTACLE IS  $\phi$ .068.
- THIS CONNECTOR ACCEPTS (2) POWER 8, OR COAX SOCKET CONTACTS IN POSITIONS A1 THRU A2, PURCHASED SEPARATELY.
- THIS CONNECTOR ACCEPTS SIZE 20 SOCKET SIGNAL CONTACTS IN POSITIONS 1 THRU 15, PURCHASED SEPARATELY.

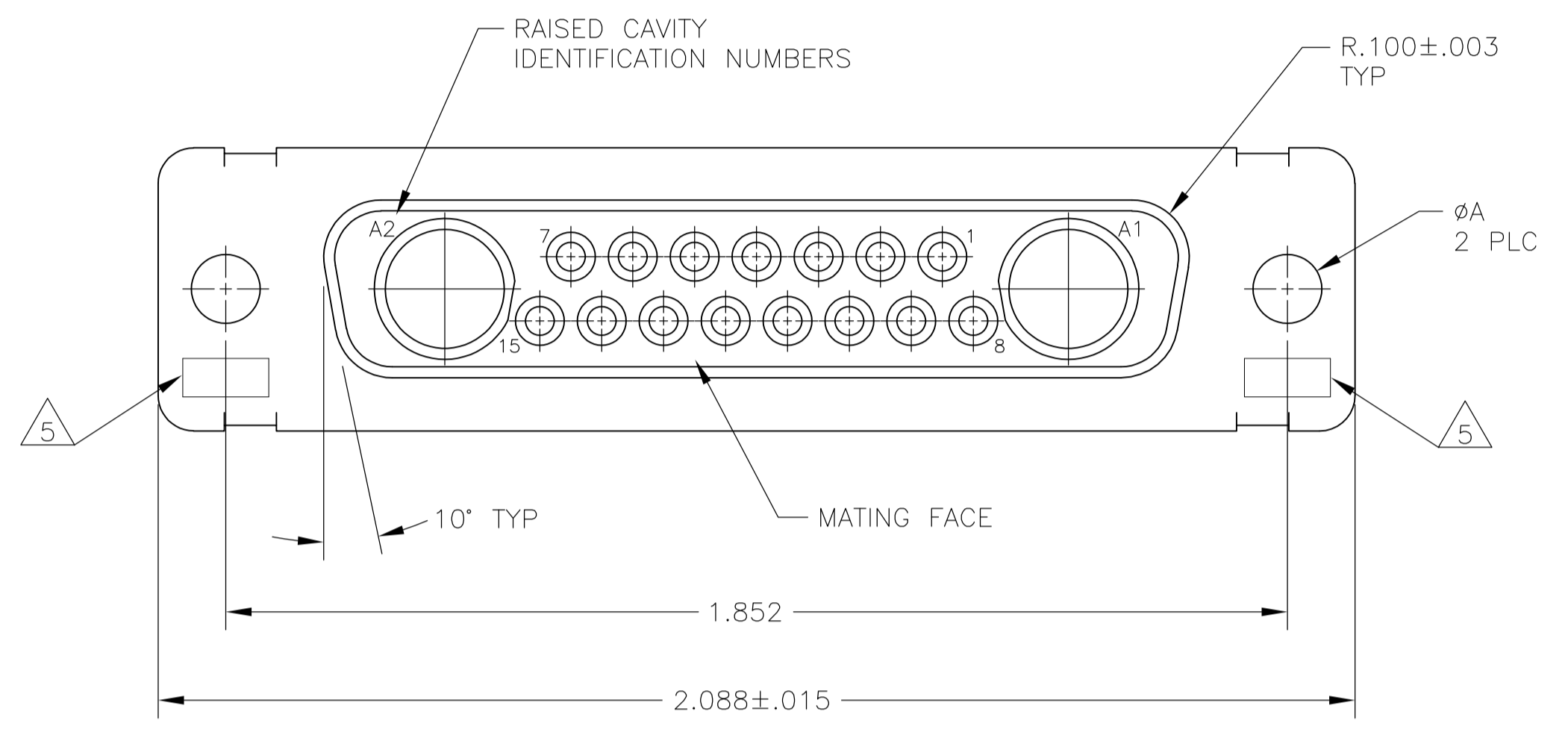

- 5 UL/CSA DESIGNATION STAMPED IN THIS AREA, OPTIONAL.
- 6 STEEL PER ASTM-A-109.
- 7 BRASS PER MIL-C-50 AND ASTM-B-36 UNS NO. C26000.
- 8 FINISH: CADMIUM PLATED PER QQ-P-416.
- 9 GOLD PLATED PER MIL-G-45204 TYPE II, GRADE C, CLASS 1 OVER COPPER PER MIL-C-14550, CLASS IV.
- 10 FINISH: TIN PER ASTM-B-545 .000200 MIN THK OVER COPPER PER AMS2418 .000100-.000200 THK.
- 11 FINISH: TIN PER ASTM-B-545 .000400 MIN THK OVER COPPER PER AMS2418 .000050 MIN THK.
- 12 FINISH: TIN PER ASTM-B-545 .000200 MIN THK OVER COPPER PER AMS2418 .000100-.000200 THK.
- 13 FINISH: ZINC PLATE PER ASTM-B-633 .000200-.000400 THK WITH SUPPLEMENTARY CHROMATE (Cr3+).

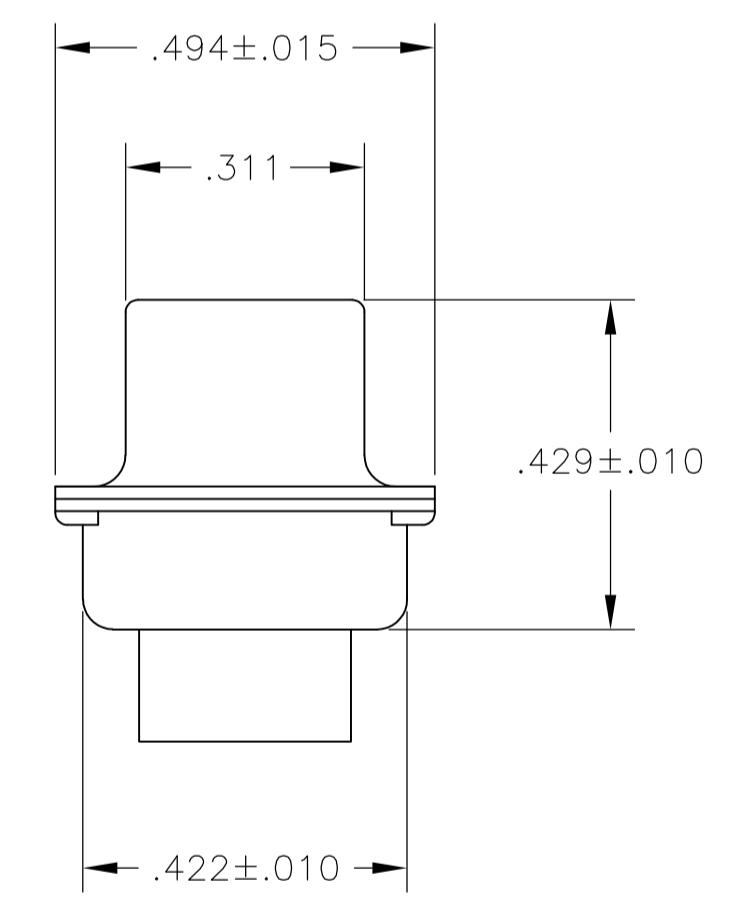
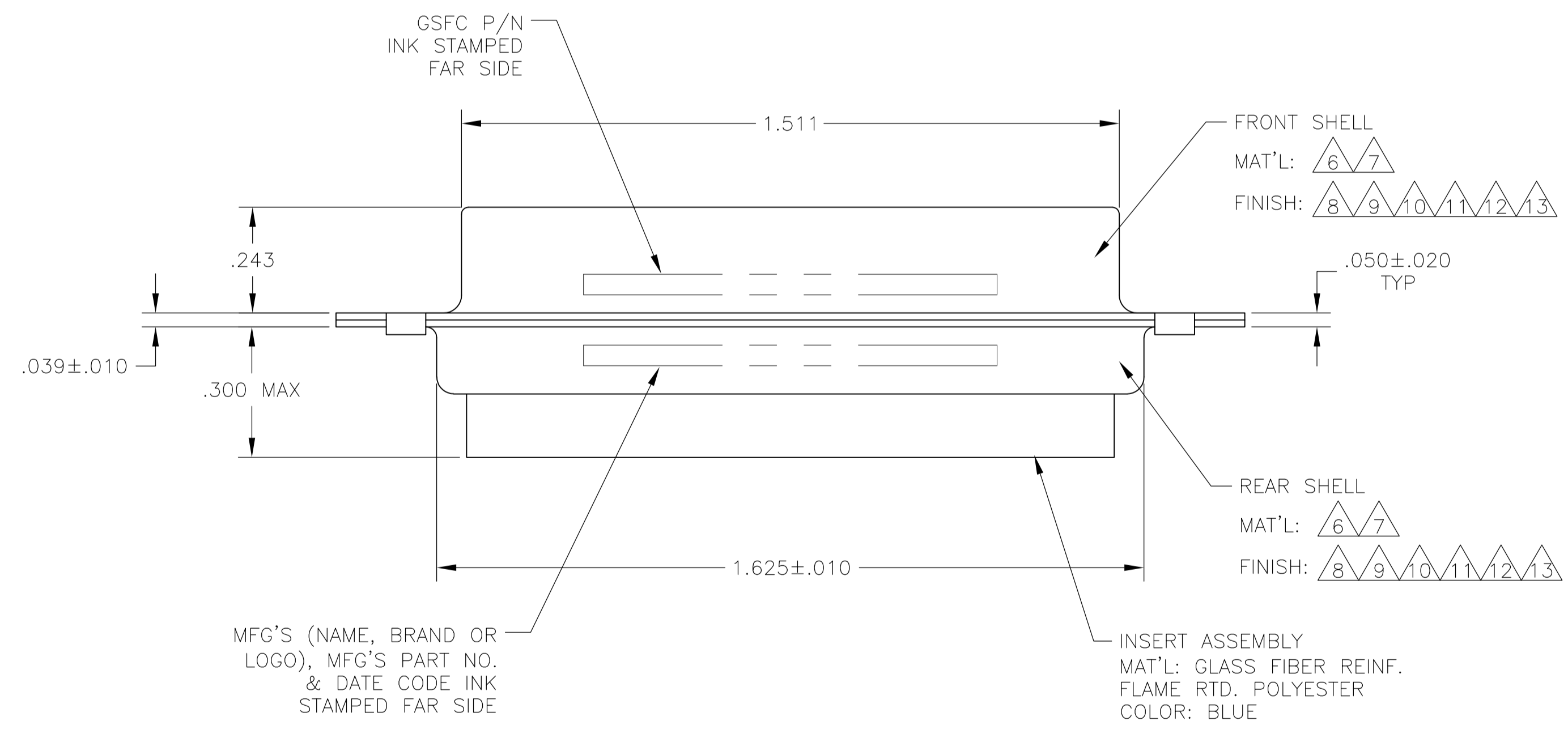

PRELIMINARY NOT RELEASED FOR PRODUCTION

REMARKS	$\phi$ A	GSFC P/N	PART NO.
6, 13	.120	-	5-212510-1
6, 12	.120	-	5-212510-4
6, 11	.120	-	212510-5
6, 10	.120	-	212510-4
7, 9	.154	311P405-13S-B-15	212510-3
7, 9	.120	311P405-13S-B-12	212510-2
6, 8	.120	-	212510-1

THIS DRAWING IS A CONTROLLED DOCUMENT.

DIMENSIONS: INCHES	TOLERANCES UNLESS OTHERWISE SPECIFIED:	DIN C.C.THOMAS 26JAN88	APPROVED: A.FMADI	DATE: 02FEB88	NAME: A.FMADI
0 PLC ± -	1 PLC ± -	2 PLC ± -	3 PLC ± .005(0.13)	4 PLC ± ± 0°-30°	ANGLES
MATERIAL	FINISH	WEIGHT	SIZE: A1	CAGE CODE: 00779	DRAWING NO: 212510
CUSTOMER DRAWING			SCALE: 4:1	SHEET: 1 OF 1	REV: L

RECEPTACLE ASSEMBLY  
AMPLIMITE 17C2  
SIZE 3, SERIES 109, COAX MIX

Tyco Electronics Corporation  
Harrisburg, PA 17105-3608